

# LAMMCO

commercial furniture + interior design

**web.** [www.lammco.net](http://www.lammco.net)

**email.** [design@lammco.net](mailto:design@lammco.net)

**phone.** 765.447.7400

**location.** 635 Erie Street Lafayette, IN 47904

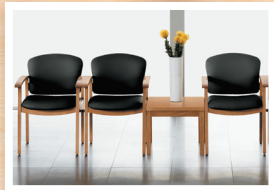

## FURNITURE SOLUTIONS FOR YOUR BUSINESS





# Table of Contents

Use this reference to quickly locate the products you want. Products are organized by section for easy navigation. Also, see the comprehensive index in the back of the catalog.

## ■ OFFICE SUITES

Laminate.....	4-27
Table Desks .....	28-30
Steel.....	32-37

## ■ SIT-TO-STAND

Tables/Desks/Active Seating .....	38-56
Ball Chairs .....	50

## ■ COMPUTER FURNITURE

Workstations.....	59-63
Stands.....	64-66
Accessories .....	67

## ■ PRIVACY PANELS

Wall Systems/Collaboration Screens .....	68, 69
--	--------

## ■ RECEPTION ROOM

Desk, Seating .....	71-79
---------------------	-------

## ■ SEATING

Leather & Vinyl.....	81-95
Mesh .....	96-113
Office .....	114-127
Big & Tall.....	137-140
24/7.....	132
Stools .....	128-136, 141-143
Nesting/Stacking/Folding.....	144-154
Casters/Chair Mats .....	155-160
Footrests/Back Supports .....	161-164

## ■ FILES

Shelf.....	166
Lateral .....	167-169
Fireproof.....	169-173
Vertical .....	174-175
Pedestal .....	176-177
Mobile .....	178-181
Storage Mobile & Multi-Media.....	182

## ■ STORAGE

Bookcases.....	184-188
Cabinets.....	189-191
Shelving.....	192-197
Lockers .....	198-200

## ■ TABLES

Occasional.....	202
Conference.....	203, 204
Training.....	205-211
Utility/Folding.....	212-217
Hospitality .....	218, 219
Indoor/Outdoor/Picnic.....	220, 221

## ■ OFFICE FURNISHINGS

Archival Filing & Storage.....	225
Art & Drafting/Tables & Files.....	226-227
Boards/Dry Erase, Porcelain .....	228-260
Cleaning & Sanitation/Brooms.....	261-262
Carts/Media & Beverage .....	263-265
Cleaning & Sanitation/Cleaning Products.....	266-268
Clocks .....	269-270
Coat Racks & Hangers .....	271-274
Glue & Adhesive/Mounting Products .....	275-276
Desk Accessories .....	277-281
Fans .....	282-283
File Folders/Hanging .....	284-286
First Aid.....	287-289
Floor Mats & Wipers.....	290-295
Frames .....	296-297
Hand Carts & Trucks .....	298-299
Heaters.....	300-301
Lamps & Lighting .....	302-305
Lecterns .....	306
Literature Racks & Displays/Floor .....	307-310
Mail Carts .....	311
Paper Towel & Dispensers/Restroom Supplies.....	312-324
Portable Files.....	325-326
Power/Surge Protectors .....	327-328
Refrigerators.....	329
Stands & Carts/Computer & Monitor .....	330-333
Signs .....	334-335
Step Stools.....	336
Tools/General .....	337
Utility Carts.....	338-339
Vacuums.....	340
Waste Can Liners.....	341-344
Waste Receptacles .....	345-350

### PRODUCTS CANNOT BE ORDERED THROUGH THIS CATALOG

The information contained in this catalog is for information purposes only and should not be used by consumers to make final buying decisions. Information is subject to change at any time without notice.

This catalog is to be used as general advertising material. Latest pricing, product information, and Prop 65 warnings are included at point of sale.

©ESSENDANT 2019 Printed in the U.S.A.

Prices shown are in U.S. dollars and are subject to change without notice; we encourage you to confirm prices when placing your order. We reserve the right to correct pricing or copy errors and to limit quantities. Company and product names appearing in this catalog are the trademarks of their respective owners. Products on the front cover may be for illustration only and may not be available for sale. Food, beverages, medicines and custom orders cannot be returned. Casters supplied with the chairs in this catalog may not be suitable for all floor types. Alternative casters are available.





**HON.**<sup>®</sup>

**POWERING HIGH  
PERFORMANCE SPACES**

# Inspiring designs

for all the ways you work.



## Focus

Sometimes you need to hear yourself think.

## Connect

Great success comes from great communication.



## Engage

Never underestimate the power of social spaces to move business forward.

## Collaborate

Where people gather, ideas are born.





## OPEN OFFICE

No matter what type of work you do, make the most of your space. Open offices encourage communication and boost productivity with adaptable working layouts that can be reimagined based on function and necessity.



Empower® Benching



Contain® Storage



Ignition® 2.0 ReActiv™ Seating



F. Preside® seated-height collaborative table G. Ceres® guest chair



# Setting the standard in **Service, Selection** and **Solutions**

Our dedicated office furniture specialists are ready to go the extra mile to make your furniture shopping experience exceptional—JUST CALL.

## More possibilities from one source

Finding the perfect fit for your workspace just got easier. We already have the largest in-stock offering and now, with just a little more lead time, we're putting even more choices within your reach. Unique colors, styles and options (noted throughout the catalog by this icon ) can highlight your business's personality and make your space feel just right!

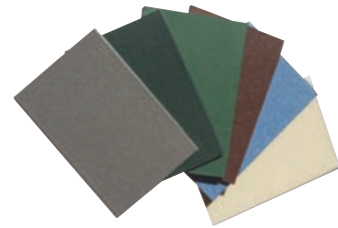
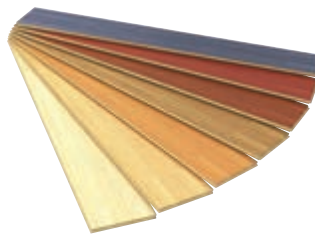

## Well crafted and well priced

Our furniture is expertly crafted yet priced to make the most of your budget. From top national brands to well-known private labels, you'll never have to make a choice between quality and affordability. Plus, our furniture is warranted for workmanship by our manufacturers.



## Maximize your space

We're here to help make your perfect office a reality—our space planning consultants are ready to design a floor plan that will make the most of your square footage. We will work with your input to create layouts in 2D and 3D elevations using the latest space-planning software. You can then use these plans to determine which furniture components will work best in your space.

## Fast Delivery

In most cases to most places, in-stock items are delivered in 24 hours. Plus, we have an expanded selection of colors and styles that ship quickly but require a few extra days for delivery. We even have delivery and set-up services to most U.S. major markets. Please call for quotes and availability in your area.





A. Empower® benching with privacy screen B. Solve® ReActiv™ task chair C. Contain® low credenza with seat cushion D. Flock mini cylinder with casters E. Brigade® 600 Series lateral file



Preside® Tables



Flock® Seating



Between™ Tables

Creative, collaborative areas invite employees to gather, brainstorm, work and relax in an open, inspiring environment that's just as comfortable and flexible as it is functional.

## COLLABORATIVE



# How to specify products

## Understanding stock numbers

### Complete stock number

Example: **HON-N103CU10**

When you do not see an underscore within a stock number, the number is complete as is. You will receive the item exactly as it is described in the copy block.

The example to the right represents the HON® Nucleus® Work Chair with Ilira®-Stretch M4Back Chair with a Black Mesh Back and Black Upholstery.

### Truncated stock number

When you see an underscore ( \_ ) at the end or in the middle of a stock number, please insert the appropriate finish or upholstery indicator to complete the stock number.

Example: **HON-N103CU\_**  
becomes **HON-N103CU19**

The addition of the upholstery indicator 103CU19 means you have selected the HON® Nucleus® Work Chair with Ilira®-Stretch M4Back Chair with a Black Mesh Back and Poppy Upholstery.

**Complete stock number.**  
No upholstery or finish option to specify.

**Truncated stock numbers.**  
Please specify upholstery or finish indicator.

Upholstery or finish indicators



## Catalog icon symbols



Meets or exceeds ANSI/BIFMA standards for safety and durability.



Indicates the maximum weight a chair can support.



Products that must be shipped freight.



Identifies items added since the last edition of this catalog.



Assembly required.



Products made with at least 10% total recycled content.



Because there is no universally accepted standard to designate products as environmentally preferable, we have adopted the green leaf symbol to highlight products that have one or more of the following attributes: reduced VOCs, compostable, biodegradable, contains recycled content, or other environmental attributes that make this product<sup>†</sup> less harmful to the environment or humans, when compared to its traditional counterparts. Many of the products marked with the green leaf symbol have been endorsed by third-party certifying organizations, and where applicable, the certifying body's logo appears next to the product's name. Please note that we have not independently verified the environmental attributes

<sup>†</sup>These environmental attributes refer to the products themselves and not the processes for manufacturing and transporting the products.

## Availability options

### In-stock products will ship immediately

Our catalog has the most extensive, readily available offering of furniture products and solutions. All items in this catalog are stocked and readily available to ship within 24 hours unless otherwise indicated.

### Special order



Requires additional lead time and cannot be returned.



# PRIVATE OFFICE

When it's time to buckle down, focus and get to work, there's nothing better than the sanctuary of distraction-free, private office to maximize your personal comfort and productivity.



Preside® Tables



Ignition® 2.0 Upholstered Seating



Voi® Desks



F. Motivate® stacking/nesting chair G. Between™ multi-purpose table



Steel Mesh

Platinum Metallic

Black

Florence Walnut

Nautilus

Black

# Office Suites

Create a space for the way you work.



**A productive, personalized space is essential**, even in this increasingly mobile world. We have the perfect pieces to shape your home base, whether you're looking for a full office suite or a sleek table desk, open plan design or private office. From traditional to contemporary, richly detailed to fresh, clean lines, our selection lets you put together an office that works for you.

Laminate Office Suites 4-27

Table Desks 28-30

Steel Office Suites 32-37



Fog

Portico Teak

Bittersweet

Silver Mesh

Black

Platinum Metallic



A. Voi® desk with o-legs and frosted glass modesty panel B. Voi® low credenza  
 C. Voi® credenza with o-leg and support pedestal D. Voi® overhead cabinet with frosted glass doors and o-legs E. Solve® 4-way stretch mesh mid-back task chair



Between™ Tables



Ignition® 2.0 ReActiv™ Seating



Motivate® Components

From casual team training sessions to all-company conferences, outfit your space with furniture solutions that combine mobility, function and style.

## MEETING

## HON.

### 94000 Series™

18th century elegance,  
21st century engineering.



- Mahogany mirror-finish worksurfaces are scratch-, stain- and spill-resistant contract grade laminate with solid hardwood edges.
- Distinctive plinth bases, raised decorative molding and antique brass-plated hardware.
- Convenient pull-out writing shelf on desk pedestals.
- Ships fully assembled (unless noted) to ease and speed installation.
- Backed by the HON Full Lifetime Warranty.
- Contains 69% pre-consumer recycled content, 3% post-consumer recycled content.



Mahogany (NN)

## Selection Guide For 94000 Series

Mahogany SIZE (W × D × H) SHPG. WT. PRICE	<b>L-Workstation with Left Pedestal Desk</b>  Single Pedestal Desk with one box, file and central locking center drawer. Return with locking box and file drawers. Cord grommets in top and back of return. Desk and Return sold and shipped separately--ORDER BOTH.		<b>L-Workstation with Right Pedestal Desk</b>  Single Pedestal Desk with one box, file and central locking center drawer. Return with locking box and file drawers. Cord grommets in top and back of return. Desk and Return sold and shipped separately--ORDER BOTH.		<b>Double Pedestal Desk</b>  One box and file drawer in each pedestal. Center drawer lock secures all drawers. 7" conference overhang on 72" desk provides kneespace for guests. Pull-out writing shelf in each desk pedestal.	
	ID LEFT PEDESTAL DESK 1 HON-94284LNN 66" × 30" × 29½" 233 lbs. 1,970.00	ID RIGHT RETURN 2 HON-94215RNN 48" × 24" × 29½" 154 lbs. 1,344.00	ID RIGHT PEDESTAL DESK 3 HON-94283RNN 66" × 30" × 29½" 233 lbs. 1,970.00	ID LEFT RETURN 4 HON-94216LNN 48" × 24" × 29½" 154 lbs. 1,344.00	ID 72" DESK 5 HON-94271NN 72" × 36" × 29½" 307 lbs. 2,397.00	ID 60" DESK 6 HON-94251NN 60" × 30" × 29½" 284 lbs. 2,255.00
Mahogany SIZE (W × D × H) SHPG. WT. PRICE	<b>Credenza with Kneespace</b>  One box and one file drawer in each pedestal, drawers lock.	<b>Stack-on Storage</b>  Overhead design saves floor space. Fits on top of Credenza with Kneespace. Four hinged doors, two compartments.	<b>Task Light for Stack-on Storage</b>  Mounts under Stack-on Storage, sold separately. Fluorescent fixture with one bulb (ind.). UL Approved.	<b>Bookcase</b>  Five fixed shelves (shelf count includes bottom of bookcase).	<b>Storage Cabinet</b>  Interior shelf adjusts in 1¼" increments. Locking.	
	ID 7 HON-94243NN 72" × 24" × 29½" 253 lbs. 2,000.00	ID 8 HON-94234NN 70" × 16½" × 37" 175 lbs. 1,443.00	ID FOR 60" OR 72" WIDE UNIT 9 HON-H870960 46½" × 31¼" 12 lbs. 270.00	ID 10 HON-94225NN 35¾" × 14¾" × 78¼" 200 lbs. 1,203.00	ID 11 HON-94291NN 37½" × 20½" × 29½" 165 lbs. 1,230.00	
Mahogany SIZE (W × D × H) SHPG. WT. PRICE	<b>Lateral File</b>  Two drawers. Single lock secures both drawers.	<b>Bookcase Hutch</b>  Fits on top of Storage Cabinet or Lateral File. Three shelves, two adjustable in 1¼" increments.	<b>Slide-Away Keyboard Platform</b>  For Credenzas or Returns. Can be positioned 2" to 3-½" below worksurface.	<b>USB AC Power Hub</b>  Fits 3" grommet holes. One grounded AC outlets. Two USB ports. 6 ft. power cord.	<b>AC Power Hub</b>  Fits 3" grommet holes. Two grounded AC outlets. 6 ft. power cord.	
	ID 37¼" WIDE FILES 12 HON-94223NN 37½" × 20½" × 29½" 172 lbs. 1,381.00	ID 13 HON-94210NN 35¾" × 14¾" × 37" 95 lbs. 924.00	ID 14 HON-4022N 17" 10 lbs. 213.00	ID 15 HON-HGRMTUSB2 3.4"w × 3.4"d × 3.4"h × 6" 2 lbs. 219.00	ID 16 HON-GRMTACX 3"w × 3"d 1 lb. 111.00	



# EDUCATION

Today's students are learning together, working in groups, and interacting with instructors. New tools and teaching methods enable learning to happen anywhere, at any time.



Smartlink® Student Desks



Build™ Tables



Smartlink® Storage



H. Abound® panel system I. Concinnity™ desk with transaction counter J. Flagship® lateral file cabinet K. Ignition® mid-back task chair L. Soothe® seating





Shown in Mahogany with HON Ignition 2.0 seating.

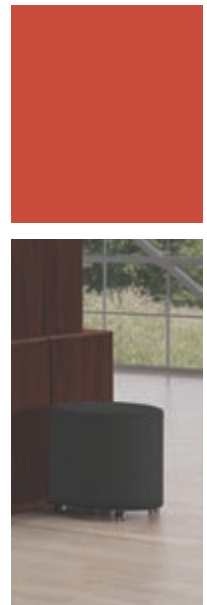

# HON. 10700 Series

## Iconic Design, Lasting Performance



- Contract grade, high-pressure laminate provides maximum protection against scratches and spills.
- Waterfall-shaped edges and rounded corners are easy on arms.
- Robust construction endures moving and handling to ensure a long life.
- Desks, credenzas, returns, files, storage cabinets and bookcases ship fully assembled (ready to set in place) to ease and speed installation.
- Locks to secure files and storage; HON "One Key" interchangeable lock design makes re-keying quick and easy.
- Backed by the HON Full Lifetime Warranty.
- Contains 3% post-consumer recycled content, 72% total recycled content.
- Level 2 Certified; Meets or Exceeds ANSI/BIFMA and ISTA Performance Standards; SCS Indoor Advantage Certified.



## Selection Guide For 10700 Series

	Double ¼ Pedestal Desk		Single ¼ Pedestal Credenza	Single ¼ Pedestal Desk	
	<p>One box and one file drawer in each pedestal. 10½" conference overhang on 72" w desk provides kneespace for guests. All drawers lock.</p>		<p>Two locking file drawers. Cord routing grommets in top and back panel.</p>	<p>Right Pedestal Desk with one box and one file drawer; drawers lock. Two cord management grommets in top.</p>	
	ID 72"	ID 60"-IDEAL FOR SMALL SPACES	ID	ID 72" DESK	ID SMALL OFFICE DESK
Cognac	1 HON-10791CO	4 HON-10771CO	7 HON-10786LCO	10 HON-10785RCC	13 HON-107885RCC
Harvest	2 HON-10791CC	5 HON-10771CC	8 HON-10786LCC	11 HON-10785RCC	14 HON-107885RCC
Mahogany	3 HON-10791NN	6 HON-10771NN	9 HON-10786LNN	12 HON-10785RNN	15 HON-107885RNN
SIZE (W × D × H)	72" × 36" × 29½"	60" × 30" × 29½"	72" × 36" × 29½"	72" × 36" × 29½"	48" × 30" × 29½"
SHPG. WT.	340 lbs.	266 lbs.	279 lbs.	279 lbs.	191 lbs.
PRICE	1,577.00	1,328.00	1,308.00	1,308.00	1,094.00
	L-Workstation with Right ¼ Pedestal Desk		L-Workstation with Left ¼ Pedestal Desk		Credenza with Kneespace
	<p>Single Pedestal Desk and Return each with one box and one file drawer. ¼ pedestals. All drawers lock. Desk and Return sold and shipped separately—ORDER BOTH.</p>		<p>Single Pedestal Desk and Return each with one box and one file drawer. ¼ pedestals. All drawers lock. Desk and Return sold and shipped separately—ORDER BOTH.</p>		<p>One box, one file drawer in each pedestal; drawers lock. Cord routing grommets in top and back panel. ¼ pedestals.</p>
	ID DESK	ID RETURN	ID DESK	ID RETURN	ID 72" CREDENZA
Cognac	16 HON-10783RCC	19 HON-10716LCO	22 HON-10784LCO	25 HON-10715RCC	28 HON-10743CO
Harvest	17 HON-10783RCC	20 HON-10716LCC	23 HON-10784LCC	26 HON-10715RCC	29 HON-10743CC
Mahogany	18 HON-10783RNN	21 HON-10716LNN	24 HON-10784LNN	27 HON-10715RNN	30 HON-10743NN
SIZE (W × D × H)	66" × 30" × 29½"	48" × 24" × 29½"	66" × 30" × 29½"	48" × 24" × 29½"	72" × 24" × 29½"
SHPG. WT.	239 lbs.	147 lbs.	239 lbs.	147 lbs.	243 lbs.
PRICE	1,193.00	879.00	1,193.00	879.00	1,419.00
					ID 60" CREDENZA
					31 HON-10765CO
					32 HON-10765CC
					33 HON-10765NN
					229 lbs.
					1,266.00

20-MF-L-FCL





A. Skip™ chair B. Smartlink® task stool C. Smartlink® 4-leg chair D. Smartlink® student desk  
E. Smartlink® learning board F. Smartlink® task chair G. Brigade® bookcase



Abound® Systems



Ignition® ReActiv™ Seating



Soothe® Seating

Our furniture is easy to use and easy to clean. And every HON healthcare solution helps caregivers work better.

## HEALTHCARE

Loft

Sublime

Platinum Metallic

Pinnacle











Beryl

Oatmeal

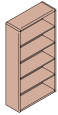
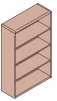
## Selection Guide For 10700 Series

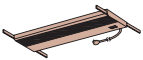
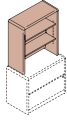
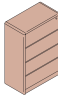

Requires additional lead time and cannot be returned.

	<b>Single Full Pedestal Desk</b>  Two box drawers, one file drawer. Drawers lock. Two cord management grommets in top. 10½" top overhang provides kneespace for guests.	<b>Full Left Pedestal Return</b>  For use with a right pedestal desk. Two locking file drawers. Cord routing grommets. Reinforced construction.	<b>Full Right Pedestal Return</b>  For use with a left pedestal desk. Two locking file drawers. Cord routing grommets. Reinforced construction.	<b>Credenza with Doors</b>  Two file drawers in each pedestal; drawers lock. Storage cabinet in center; doors do not lock. Two cord management grommets in top.	<b>Double Full Pedestal Desk</b>  Two box drawers; one file drawer on left, two file drawers on right. Drawers lock. Two cord management grommets in top. 10½" top overhang provides kneespace for guests.
	ID <b>PEDESTAL ON RIGHT</b> 1 HON-10787RCO 2 HON-10787RCC 3 HON-10787RNN 72" × 36" × 29½" 317 lbs. PRICE 1,744.00	ID <b>PEDESTAL ON LEFT</b> 4 HON-10788LCO 5 HON-10788LCC 6 HON-10788LNN 72" × 36" × 29½" 317 lbs. PRICE 1,744.00	ID 7 HON-10712LCO 8 HON-10712LCC 9 HON-10712LNN 48" × 24" × 29½" 158 lbs. PRICE 1,073.00	ID 10 HON-10711RCO 11 HON-10711RCC 12 HON-10711RNN 48" × 24" × 29½" 158 lbs. PRICE 1,073.00	ID 13 HON-10742CO 14 HON-10742CC 15 HON-10742NN 72" × 24" × 29½" 314 lbs. PRICE 2,022.00
Cognac Harvest Mahogany SIZE (W × D × H) SHPG. WT. PRICE	<b>Bookcases</b>     Fixed shelves. Full-finished back. Shelf count includes bottom of bookcase. No assembly required.				
	ID <b>FIVE SHELVES—FIXED</b> 19 HON-10755CO 20 HON-10755CC 21 HON-10755NN 36" × 13¼" × 71" 187 lbs. PRICE 1,005.00	ID <b>FOUR SHELVES—FIXED</b> 22 HON-10754CO 23 HON-10754CC 24 HON-10754NN 36" × 13¼" × 57½" 156 lbs. PRICE 850.00	ID <b>THREE SHELVES—FIXED</b> 25 HON-10753CO 26 HON-10753CC 27 HON-10753NN 36" × 13¼" × 43¾" 122 lbs. PRICE 754.00	ID <b>TWO SHELVES—FIXED</b> 28 HON-10752CO 29 HON-10752CC 30 HON-10752NN 36" × 13¼" × 29¾" 90 lbs. PRICE 625.00	
Cognac Harvest Mahogany SIZE (W × D × H) SHPG. WT. PRICE	<b>Task Light for Stack-on Storage</b>  Mounts under Stack-on Storage (sold separately). Fluorescent fixture with one bulb (incl.). UL Approved.	<b>Bookcase Hutch</b>  Fits on top of Lateral File or Storage Cabinet. Two shelves, adjustable in 1¼" increments. Cord slot at bottom of back panel.	<b>Lateral Files</b>  Mechanical interlock allows only one drawer to open at a time to prevent tipping. Hangrails for legal/letter filing. Locking.		
	ID <b>FOR 60" OR 72" WIDE UNIT</b> 31 HON-H870960 46½" × 31¼" 12 lbs. PRICE 270.00	ID 32 HON-107292CO 33 HON-107292CC 34 HON-107292NN 32¾" × 14¾" × 37½" 93 lbs. PRICE 677.00	ID <b>36" WIDE FILES—FOUR-DRAWER</b> 35 HON-107699CO 36 HON-107699CC 37 HON-107699NN 36" × 20" × 59½" 296 lbs. PRICE 2,396.00	ID <b>36" WIDE FILES—TWO-DRAWER</b> 38 HON-10762CO 39 HON-10762CC 40 HON-10762NN 36" × 20" × 29½" 168 lbs. PRICE 1,128.00	
Cognac Harvest Mahogany SIZE (W × D × H) SHPG. WT. PRICE	<b>Storage Cabinets</b>  One adjustable interior shelf. Locking.	<b>Center Drawer</b>  Use 26" wide drawer with Double Pedestal Desk and Credenza with kneespace. Use 22" wide drawer with Single Pedestal Desk, Single Pedestal Credenza and Returns. Built-in pencil tray.		<b>USB AC Power Hub</b>  Fits 3" grommet holes. One grounded AC outlet. Two USB ports. 6 ft. power cord.	<b>AC Power Hub</b>  Fits 3" grommet holes. Two grounded AC outlets. 6 ft. power cord.
	ID 41 HON-107291CO 42 HON-107291CC 43 HON-107291NN 36" × 20" × 29½" 144 lbs. PRICE 913.00	ID <b>22" WIDE</b> 44 HON-1522CO 45 HON-1522C 46 HON-1522N 22" × 15¾" × 2½" 11 lbs. PRICE 104.00	ID <b>26" WIDE</b> 47 HON-1526CO 48 HON-1526C 49 HON-1526N 26" × 15¾" × 2½" 12 lbs. PRICE 198.00	ID 50 HON-HGRMTUSB2 3.4"w × 3.4"d × 3.4"h × 6" 2 lbs. PRICE 219.00	ID 51 HON-GRMTACX 3"w × 3"d 1 lb. PRICE 111.00
Cognac Harvest Mahogany SIZE (W × D × H) SHPG. WT. PRICE					



# CAFÉ & COMMUNITY

Because it's a place for everyone, your common area has to be up for anything.



A Between™ round disc-base table B Motivate® 4-leg chair



Arrange™ Tables



Accommodate® Seating



Grove® Seating



C. Flock® square modular seating D. Flock® wedge modular seating  
E. Flock® cube table F. Flagship® lateral file cabinet with laminate topper

**HON.** 10700 Series™ Full Pedestals

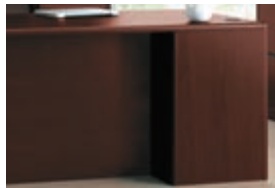

Breakfront Modesty Panel



**Store to the floor**

Full-to-floor pedestals to maximize storage space

**Approach side**

Breakfront modesty panel design contains "hideaway" wire storage for easy cord management



Mahogany (NN)

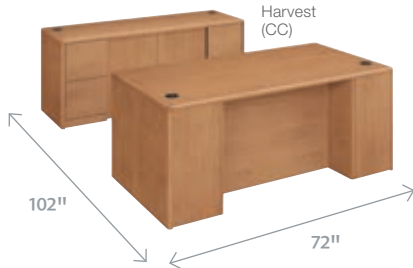

Harvest (CC)

Qty.	Item No.	Description	Price
1	HON-10799NN	<b>Double Full Pedestal Desk</b>	<b>2,022.00</b>

Qty.	Item No.	Description	Price
1	HON-10799CC	<b>Full Pedestal Desk &amp; Credenza with Doors Workstation</b>	<b>4,044.00</b>
1	HON-10742CC	<b>Double Full Pedestal Desk Credenza with Doors</b>	

Selection Guide For 10700 Series

<p>Cognac Harvest Mahogany</p> <p>SIZE (W x D x H) 72" x 36" x 29½"</p> <p>SHPG. WT. 317 lbs.   </p> <p>PRICE 1,744.00</p>	<p><b>Single Full Pedestal Desk</b></p> <p>Two box drawers, one file drawer; drawers lock. Two cord management grommets in top. 10½" top overhang provides kneespace for guests.</p> <table border="0"> <tr> <td> <p>ID <b>PEDESTAL ON RIGHT</b></p> <p>1 HON-10787RCO</p> <p>2 HON-10787RCC</p> <p>3 HON-10787RNN</p> </td> <td> <p>ID <b>PEDESTAL ON LEFT</b></p> <p>4 HON-10788LCO</p> <p>5 HON-10788LCC</p> <p>6 HON-10788LNN</p> </td> </tr> </table>	<p>ID <b>PEDESTAL ON RIGHT</b></p> <p>1 HON-10787RCO</p> <p>2 HON-10787RCC</p> <p>3 HON-10787RNN</p>	<p>ID <b>PEDESTAL ON LEFT</b></p> <p>4 HON-10788LCO</p> <p>5 HON-10788LCC</p> <p>6 HON-10788LNN</p>	<p><b>Full Left Pedestal Return</b></p> <p>Make your work space work for you with this left return. Exclusive reinforced construction ensures that it withstands daily wear and tear like no other.</p> <table border="0"> <tr> <td> <p>ID</p> <p>7 HON-10712LCO</p> <p>8 HON-10712LCC</p> <p>9 HON-10712LNN</p> </td> <td> <p>48" x 24" x 29½"</p> <p>158 lbs.   </p> </td> </tr> </table> <p>1,073.00</p>	<p>ID</p> <p>7 HON-10712LCO</p> <p>8 HON-10712LCC</p> <p>9 HON-10712LNN</p>	<p>48" x 24" x 29½"</p> <p>158 lbs.   </p>	<p><b>Full Right Pedestal Return</b></p> <p>Polish up your work space with this right return. Exclusive reinforced construction ensures that it withstands daily wear and tear like no other.</p> <table border="0"> <tr> <td> <p>ID</p> <p>10 HON-10711RCO</p> <p>11 HON-10711RCC</p> <p>12 HON-10711RNN</p> </td> <td> <p>48" x 24" x 29½"</p> <p>158 lbs.   </p> </td> </tr> </table> <p>1,073.00</p>	<p>ID</p> <p>10 HON-10711RCO</p> <p>11 HON-10711RCC</p> <p>12 HON-10711RNN</p>	<p>48" x 24" x 29½"</p> <p>158 lbs.   </p>
	<p>ID <b>PEDESTAL ON RIGHT</b></p> <p>1 HON-10787RCO</p> <p>2 HON-10787RCC</p> <p>3 HON-10787RNN</p>	<p>ID <b>PEDESTAL ON LEFT</b></p> <p>4 HON-10788LCO</p> <p>5 HON-10788LCC</p> <p>6 HON-10788LNN</p>							
<p>ID</p> <p>7 HON-10712LCO</p> <p>8 HON-10712LCC</p> <p>9 HON-10712LNN</p>	<p>48" x 24" x 29½"</p> <p>158 lbs.   </p>								
<p>ID</p> <p>10 HON-10711RCO</p> <p>11 HON-10711RCC</p> <p>12 HON-10711RNN</p>	<p>48" x 24" x 29½"</p> <p>158 lbs.   </p>								
<p><b>Credenza with Doors</b></p> <p>Two file drawers in each pedestal, drawers lock. Storage cabinet in center; doors do not lock. Two cord management grommets in top.</p> <table border="0"> <tr> <td> <p>ID</p> <p>13 HON-10742CO</p> <p>14 HON-10742CC</p> <p>15 HON-10742NN</p> </td> <td> <p>72" x 24" x 29½"</p> <p>314 lbs.   </p> </td> </tr> </table> <p>2,022.00</p>	<p>ID</p> <p>13 HON-10742CO</p> <p>14 HON-10742CC</p> <p>15 HON-10742NN</p>	<p>72" x 24" x 29½"</p> <p>314 lbs.   </p>	<p><b>Double Full Pedestal Desk</b></p> <p>Two box drawers, one file drawer on left; two file drawers on right; drawers lock. Two cord management grommets in top. 10½" top overhang provides kneespace for guests.</p> <table border="0"> <tr> <td> <p>ID</p> <p>16 HON-10799CO</p> <p>17 HON-10799CC</p> <p>18 HON-10799NN</p> </td> <td> <p>72" x 36" x 29½"</p> <p>371 lbs.   </p> </td> </tr> </table> <p>2,022.00</p>	<p>ID</p> <p>16 HON-10799CO</p> <p>17 HON-10799CC</p> <p>18 HON-10799NN</p>	<p>72" x 36" x 29½"</p> <p>371 lbs.   </p>				
<p>ID</p> <p>13 HON-10742CO</p> <p>14 HON-10742CC</p> <p>15 HON-10742NN</p>	<p>72" x 24" x 29½"</p> <p>314 lbs.   </p>								
<p>ID</p> <p>16 HON-10799CO</p> <p>17 HON-10799CC</p> <p>18 HON-10799NN</p>	<p>72" x 36" x 29½"</p> <p>371 lbs.   </p>								

20-MF-L-FCL



# Office Suites Laminate

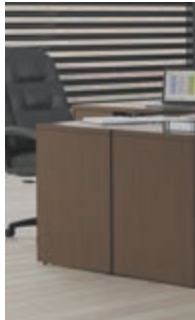

## HON 10500 Series™

The workhorse of the workplace.



- Durable, easy-care laminate is scratch, spill and stain resistant.
- Drawers are equipped with smooth, quiet action slides.
- Strong inner frame construction built for trouble free performance and long life.
- Bookcase, desks, credenzas, returns, storage cabinet, files and pedestals ship fully assembled to ease and speed installation.
- All drawers lock.
- Backed by the HON Full Lifetime Warranty.
- Contains 69% pre-consumer recycled content, 3% post-consumer recycled content.
- Level 2 Certified; Meets or Exceeds ANSI/BIFMA Standards; SCS Indoor Advantage Gold Certified.

**NO RETURN** Requires additional lead time and cannot be returned.

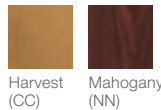

## Selection Guide For 10500 Series Full Pedestals

	Double Pedestal Desk	Single Pedestal Desk	Return		
	Two box drawers; one file drawer on left, two file drawers on right. Drawers lock. Grommets in top to route/hide cords. 10½" top overhang provides kneespace for guests.	Two box drawers and one file drawer. Drawers lock. Grommets in top to route/hide cords. 10½" overhang on front of desk provides kneespace for guests.	Use with Single Pedestal Desk to form an L-Workstation. Two locking file drawers. Cord routing grommets in top and back panel.		
	<b>ID BOW TOP</b>	<b>ID RECTANGLE TOP</b>	<b>ID WITH RIGHT PEDESTAL</b>	<b>ID WITH LEFT PEDESTAL</b>	
	1 HON-105899CC	3 HON-105890CC	5 HON-105895RCC	7 HON-105896LCC	
	2 HON-105899NN	4 HON-105890NN	6 HON-105895RNN	8 HON-105896LNN	
	72" × 36" × 29½"	72" × 36" × 29½"	72" × 36" × 29½"	72" × 36" × 29½"	
	315 lbs.	340 lbs.	279 lbs.	279 lbs.	
	PRICE 1,867.00	1,702.00	1,361.00	1,361.00	
Harvest Mahogany SIZE (W × D × H) SHPG. WT. PRICE					
	Bridge	Credenza with Kneespace	Single Pedestal Credenza	Stack-on Storage	Stack-on Storage for Return
	Connects Single Pedestal Desk and Single Pedestal Credenza to form a U-Workstation.	Four locking file drawers. Cord pass-through in back panel.	Two locking file drawers. Cord pass-through in back panel.	Space-saving hutch for credenzas, returns or rectangle desks. Two compartments. Four self-closing, adjustable hinged doors.	Self-closing, adjustable hinged doors. Use on 48" wide Return.
	<b>ID 47"</b>	<b>ID</b>	<b>ID WITH RIGHT PEDESTAL</b>	<b>ID 72"</b>	<b>ID 48"</b>
	13 HON-10570CC	15 HON-105900CC	17 HON-105903RCC	21 HON-10534CC	23 HON-105323CC
	14 HON-10570NN	16 HON-105900NN	18 HON-105903RNN	22 HON-10534NN	24 HON-105323NN
	47" × 24" × 29½"	72" × 24" × 29½"	72" × 24" × 29½"	72" × 14½" × 37½"	48" × 14½" × 37½"
	72 lbs.	274 lbs.	226 lbs.	185 lbs.	141 lbs.
	PRICE 364.00	1,493.00	1,210.00	1,011.00	850.00
Harvest Mahogany SIZE (W × D × H) SHPG. WT. PRICE					
	Mobile Pedestal	Round Table			
	Store supplies and letter/legal size hanging files. Smooth, flat edges. Roll easily on hidden casters. Drawers lock. Use freestanding or under 24"D-36"D Shells.	Use in offices or open areas for meetings. Adjustable leveling glides on base. Top and Base sold and shipped separately—ORDER BOTH.			
	<b>3 DRAWERS—BOX/BOX/FILE - TOP BOX DRAWER DOES NOT LOCK.</b>	<b>2 DRAWERS—FILE/FILE - HANG RAILS ENABLE SIDE-TO-SIDE LETTER AND LEGAL FILING AS WELL AS FRONT-TO-BACK LETTER FILING.</b>			
	<b>ID</b>	<b>ID 48" TOP</b>	<b>ID 42" TOP</b>	<b>ID CYLINDER BASE</b>	
	25 HON-105102CC	29 HON-TLD48GCNC	31 HON-TLD42GCNC	33 HON-TLRAC	
	26 HON-105102NN	30 HON-TLD48GNNN	32 HON-TLD42GNNN	34 HON-TLRAN	
	15¾" × 22¾" × 28"	48"	42"	18" dia. × 28h"	
	121 lbs.	66 lbs.	51 lbs.	42 lbs.	
	PRICE 854.00	519.00	469.00	681.00	
Harvest Mahogany SIZE (W × D × H) SHPG. WT. PRICE					

20-MF-L-FCL



# 10500 Series™ ¾ Pedestals with Ancillary Components

In-Stock



Harvest (CC) Mahogany (NN)

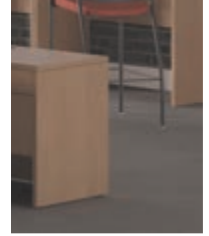

## Selection Guide for 10500 Series™ ¾ Pedestals

	Double Pedestal Desk			Curved Corner L-Workstation		
	One box and one file drawer in each locking pedestal. 10¼" overhang on front of 72" w desks provides kneespace for guests. 60" w desk is ideal for small offices. Grommets in top to route/hide cords.			Curved Corner Unit has cord grommet in top. Curved Returns have grommet in top and cord pass-through in back panel. Curved Returns not freestanding. Locking box and file drawer.		
	ID BOW TOP	ID 72" RECTANGLE TOP	ID 60" RECTANGLE TOP	ID CURVED RIGHT RETURN	ID CURVED LEFT RETURN	ID CURVED CORNER UNIT
Harvest	1 HON-10595CC	3 HON-10593CC	7 HON-10573CC	9 HON-105817RCC	11 HON-105818LCC	13 HON-105810CC
Mahogany	2 HON-10595NN	4 HON-10593NN	8 HON-10573NN	10 HON-105817RNN	12 HON-105818LNN	14 HON-105810NN
Pinnacle		5 HON-10593PINC				
Shaker Cherry		6 HON-10593FF				
SIZE (W x D x H)	72" x 36" x 29½"	72" x 36" x 29½"	60" x 30" x 29½"	42" x 24" x 29½"	42" x 24" x 29½"	36" x 36" x 29½"
SHPG. WT.	300 lbs.	320 lbs.	271 lbs.	134 lbs.	134 lbs.	128 lbs.
PRICE	1,560.00	1,391.00	1,172.00	837.00	837.00	773.00
	Bridge			Single Pedestal Desk		
	Connects Single Pedestal Desk and Single Pedestal Credenza to form a U-Workstation.			For Large "L" workstations, use Left Desk with a Right Return or Right Desk with a Left Return. For "U" workstations, attach to a Bridge and Single Pedestal Credenza. Grommets in top route/hide cords. Locking box and file drawers. Desk and Return sold and shipped separately—ORDER BOTH.		
	ID 47"	ID RIGHT DESK	ID LEFT DESK	ID RIGHT DESK	ID LEFT DESK	
Harvest	15 HON-10570CC	17 HON-10585RCC	19 HON-10586LCC	21 HON-10583RCC	25 HON-10584LCC	
Mahogany	16 HON-10570NN	18 HON-10585RNN	20 HON-10586LNN	22 HON-10583RNN	26 HON-10584LNN	
Pinnacle				23 HON-10583RPINC	27 HON-10584LPINC	
Shaker Cherry				24 HON-10583RFF	28 HON-10584LFF	
SIZE (W x D x H)	47" x 24" x 29½"	72" x 36" x 29½"	72" x 36" x 29½"	66" x 30" x 29½"	66" x 30" x 29½"	
SHPG. WT.	72 lbs.	279 lbs.	279 lbs.	229 lbs.	229 lbs.	
PRICE	364.00	1,182.00	1,182.00	1,039.00	1,039.00	
	"L" Workstation		Credenza with Kneespace		Single Pedestal Credenza	
	Grommet in top and cord pass-through in back panel. Locking box and file drawer.		One box and one file drawer in each locking pedestal. Cord pass-through in back panel.		Locking box and file drawers. Cord pass-through in back panel. Use with 72" Single Pedestal Desk and Bridge to form a U-Workstation.	
	ID RIGHT RETURN	ID LEFT RETURN	ID 72"	ID 60"	ID RIGHT CREDENZA	ID LEFT CREDENZA
Harvest	29 HON-10515RCC	33 HON-10516LCC	37 HON-10543CC	41 HON-10565CC	43 HON-10545RCC	45 HON-10546LCC
Mahogany	30 HON-10515RNN	34 HON-10516LNN	38 HON-10543NN	42 HON-10565NN	44 HON-10545RNN	46 HON-10546LNN
Pinnacle	31 HON-10515RPINC	35 HON-10516LPINC	39 HON-10543PINC			
Shaker Cherry	32 HON-10515RFF	36 HON-10516LFF	40 HON-10543FF			
SIZE (W x D x H)	48" x 24" x 29½"	48" x 24" x 29½"	72" x 24" x 29½"	60" x 24" x 29½"	72" x 24" x 29½"	72" x 24" x 29½"
SHPG. WT.	147 lbs.	147 lbs.	243 lbs.	229 lbs.	212 lbs.	212 lbs.
PRICE	837.00	837.00	1,240.00	1,172.00	1,023.00	1,023.00
	Stack-on Storage			Special Order		
	Space-saving hutch for credenzas, returns or rectangle desks. Two compartments. Four self-closing, adjustable hinged doors.			Pinnacle (PINC) Shaker Cherry (FF)		
	ID 72"	ID 60"	ID 48"			
Harvest	47 HON-10534CC	51 HON-105324CC	53 HON-105323CC			
Mahogany	48 HON-10534NN	52 HON-105324NN	54 HON-105323NN			
Pinnacle	49 HON-10534PINC					
Shaker Cherry	50 HON-10534FF					
SIZE (W x D x H)	72" x 14¾" x 37¾"	60" x 14¾" x 37¾"	48" x 14¾" x 37¾"			
SHPG. WT.	185 lbs.	164 lbs.	141 lbs.			
PRICE	1,011.00	943.00	850.00			





# Office Suites Laminate



**L-Workstation** **1,876.00**

Qty.	Item No.	Description
1	HON-10584LNN	<b>66" Left Pedestal Desk</b>
1	HON-10515RNN	<b>Right Pedestal Return</b>

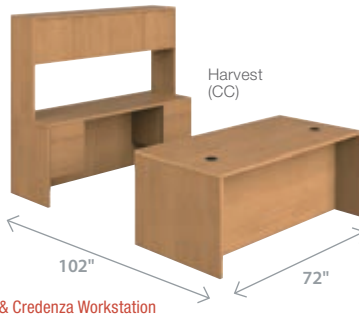

**Desk & Credenza Workstation with Stack-on Storage, 72"** **3,642.00**

Qty.	Item No.	Description
1	HON-10593CC	<b>72" Rectangle Top Double Pedestal Desk</b>
1	HON-10543CC	<b>72" Credenza with Kneespace</b>
1	HON-10534CC	<b>72" Stack-on Storage</b>

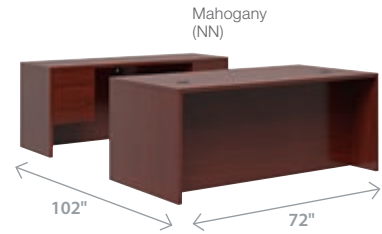

**Desk & Credenza Workstation** **2,631.00**

Qty.	Item No.	Description
1	HON-10593NN	<b>72" Rectangle Top Double Pedestal Desk</b>
1	HON-10543NN	<b>72" Credenza with Kneespace</b>

**In-Stock**

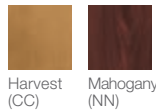

Harvest (CC) Mahogany (NN)

**Special Order**



Pinnacle (PINC) Shaker Cherry (FF)



Requires additional lead time and cannot be returned.

**\*IMPORTANT:** When ordering special order items, add the finish code to the model number. Codes vary in length and placement. Example: ABC-12345AB

## Selection Guide for 10500 Series™ Ancillary Components

	Laminate Bookcase				Task Light for Stack-on Storage	
	Fixed shelves. No assembly required.				Mounts under Stack-on Storage, sold separately. Fluorescent fixture with one bulb (incl.). UL Approved.	
	ID <b>FIVE SHELVES</b>	ID <b>FOUR SHELVES</b>	ID <b>THREE SHELVES</b>	ID <b>TWO SHELVES</b>	ID <b>FOR 48" WIDE UNIT— WITH ELECTRONIC BALLAST.</b>	ID <b>FOR 60" OR 72" WIDE UNIT</b>
Harvest Mahogany	1 HON-105535CC	3 HON-105534CC	5 HON-105533CC	7 HON-105532CC	9 HON-H870942	10 HON-H870960
SIZE (W × D × H)	36" × 13½" × 71"	36" × 13½" × 57¼"	36" × 13½" × 43¾"	36" × 13½" × 29¾"	34¾" × 31¼"	46½" × 31¼"
SHPG. WT.	187 lbs.	156 lbs.	122 lbs.	90 lbs.	10 lbs.	12 lbs.
PRICE	825.00	710.00	602.00	474.00	250.00	270.00
	<b>Slide-Away Keyboard Platform</b>	<b>End Cap Bookshelf</b>	<b>Bookcase Hutch</b>	<b>Lateral File</b>		
	For Credenzas or Returns. Can be positioned 2" to 3-½" below worksurface.	One adjustable shelf. Position at end of 24" deep Credenza or Returns, or use as freestanding Corner Bookcase.	For use on top of Two-Drawer Lateral File or Storage Cabinet with Doors. Two adjustable shelves.	For letter/legal size hanging files. All drawers lock.		
	ID	ID <b>TWO SHELVES</b>	ID	ID <b>36" WIDE FILES— FOUR-DRAWER</b>	ID <b>36" WIDE FILES— TWO-DRAWER</b>	
Harvest Mahogany	11 HON-4022C	13 HON-105520CC	15 HON-105292CC	17 HON-10516CC	19 HON-10563CC	
SIZE (W × D × H)	17"	14 HON-105520NN	16 HON-105292NN	18 HON-10516NN	20 HON-10563NN	
SHPG. WT.	10 lbs.	24" × 24" × 29½"	36" × 14¾" × 37¼"	36" × 20" × 59½"	36" × 20" × 29½"	
PRICE	213.00	84 lbs.	103 lbs.	305 lbs.	170 lbs.	
	<b>Storage Cabinet with Doors</b>	<b>Center Drawer</b>	<b>USB AC Power Hub</b>	<b>AC Power Hub</b>	<b>Core Removable Lock Kit</b>	
	Locking doors conceal one adjustable shelf.	Use 26" wide drawer with Double Pedestal Desk and Credenza with kneespace. Use 22" wide drawer with Single Pedestal Desk, Single Pedestal Credenza and Returns. Built-in pencil tray.	Fits 3" grommet holes. One grounded AC outlet. Two USB ports. 6 ft. power cord.	Fits 3" grommet holes. Two grounded AC outlets. 6 ft. power cord.	Replaces lock core in Desks, Credenzas, Returns, Mobile Pedestals, Lateral Files and Storage Cabinets. Makes rekeying easy. Order one core kit per unit	
	ID	ID <b>22" WIDE</b>	ID	ID	ID	
Harvest Mahogany	21 HON-105291CC	23 HON-1522C	27 HON-HGRMTUSB2	28 HON-GRMTACX	29 HON-F23BX	
SIZE (W × D × H)	36" × 20" × 29½"	24 HON-1522N	3.4"w × 3.4"d × 3.4"h × 6"l	3"w × 3"d		
SHPG. WT.	147 lbs.	ID <b>26" WIDE</b>	2 lbs.	1 lb.		
PRICE	781.00	25 HON-1526C	219.00	111.00	32.00	
		26 HON-1526N				
		22" × 15¾" × 2½"				
		11 lbs.				
		26" × 15¾" × 2½"				
		12 lbs.				

20-MF-L-FCL



Standing-Height L-Workstation shown in Mahogany with HON Solve® ReActiv™ Back Task Stools.

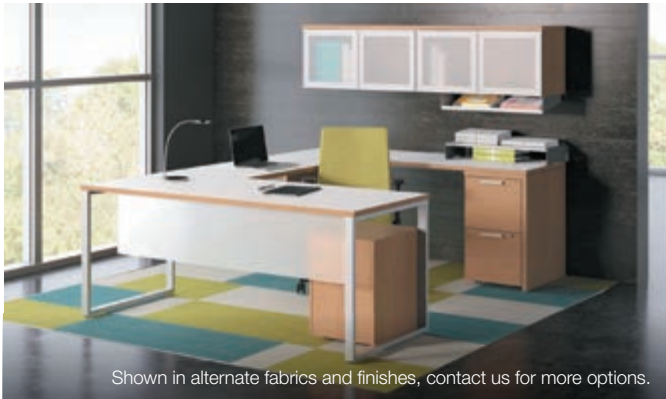

Shown in alternate fabrics and finishes, contact us for more options.



Shown in alternate fabrics and finishes, contact us for more options.



Requires additional lead time and cannot be returned.



Harvest (CC)



Mahogany (NN)

## Selection Guide For 10500 Series™ Standing Height Workstations

### Standing Height Desk Shell



Use alone or with 48" high standing height return shell for "L" Workstation. Short modesty/back panel for easy access to wall power outlets.

### Standing Height Return Shell



Non-handed design. Connects to standing height desk shell. Short modesty/back panel for easy access to wall power outlets.

### Standing Height Hanging Pedestal



Stores supplies and letter/legal size hanging files. Middle and bottom drawers lock. Unfinished top and back.

20-MF-L-FCL

	Standing Height Desk Shell			Standing Height Return Shell			Standing Height Hanging Pedestal	
	ID 60" x 30"	ID 60" x 24"	ID 48" x 24"	ID	ID 2 DRAWERS			
Harvest	1 HON-105397CC	3 HON-105393CC	5 HON-105392CC	7 HON-105663CC	9 HON-10501C			
Mahogany	2 HON-105397NN	4 HON-105393NN	6 HON-105392NN	8 HON-105663NN	10 HON-10501N			
SIZE (W x D x H)	60" x 30" x 42"	60" x 24" x 42"	48" x 24" x 42"	48" x 24" x 42"	15 1/2" x 22 3/4" x 17 3/4"			
SHPG. WT.	185 lbs.	154 lbs.	143 lbs.	96 lbs.	57 lbs.			
PRICE	837.00	772.00	722.00	606.00	523.00			

Prices subject to change without notice. Visit our website for the latest pricing and product information.

# Office Suites Laminate



## Alera® Valencia™ Series

Configurable and versatile office suites to enhance productivity.

- Durable woodgrain laminate finishes.
- Commercial-grade 1" thick worksurface and side panels are water-, scratch- and dent-resistant, featuring protective edge banding.
- Matching finishes with Valencia™ Series desking, bookcase storage components and conference tables.
- Leveling glides compensate for uneven floors.
- Manufacturer's limited five-year warranty.
- Meets or exceeds ANSI/BIFMA Standards.

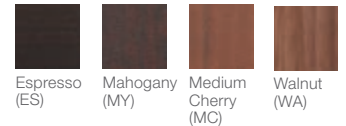

### Selection Guide For Alera® Valencia™ Series

	Bow Front Desk Shell			Straight Front Desk Shells				D-Top Desk	
	Arched front with up to 18" of conference overhang. Two grommets for cable and wire management. Full-length modesty panel for privacy.			Combine with a Return/Bridge to create an "L" format desk, or add a Credenza to complete a full "U" workstation. Two wire management grommets. Full length modesty panel for privacy.				Not freestanding. Use with Return/Bridge. One wire management grommet.	
	ID 72"			ID 72"		ID 66"	ID 60"	ID 48"	ID 72"
Espresso	1 ALE-VA227236ES			5 ALE-VA217236ES		9 ALE-VA216630ES	13 ALE-VA216030ES	17 ALE-VA214830ES	21 ALE-VA277236ES
Mahogany	2 ALE-VA22-7236MY			6 ALE-VA21-7236MY		10 ALE-VA21-6630MY	14 ALE-VA21-6030MY	18 ALE-VA21-4830MY	22 ALE-VA27-7236MY
Medium Cherry	3 ALE-VA22-7236MC			7 ALE-VA21-7236MC		11 ALE-VA21-6630MC	15 ALE-VA21-6030MC	19 ALE-VA21-4830MC	23 ALE-VA27-7236MC
Walnut	4 ALE-VA227236WA			8 ALE-VA217236WA		12 ALE-VA216630WA	16 ALE-VA216030WA	20 ALE-VA214830WA	24 ALE-VA277236WA
SIZE (W x D x H)	71" x 41½" x 29½"			71" x 35½" x 29½"		65" x 29½" x 29½"	59½" x 29½" x 29½"	47¼" x 29½" x 29½"	71" x 35½" x 29½"
SHPG. WT.	158 lbs. 📦 📦			150 lbs. 📦 📦		129 lbs. 📦 📦	120 lbs. 📦 📦	106 lbs. 📦 📦	112 lbs. 📦 📦
PRICE	\$25.00			\$470.00		\$410.00	\$385.00	\$350.00	\$335.00
	Reversible Return/Bridge Shell			Mobile Workstation Desk			Credenza Shell		
	Universal application as either a return or bridge, in left or right-handed configurations. Create "U" or "L" shaped workstations. One wire management grommet.			Slide-out keyboard tray. Two grommets. Undermount interior shelf. Two-thirds height back modesty panel for privacy. Four casters (two locking) for mobility.			Two wire management grommets. Full-height modesty panel. Add an Open Storage Hutch or File Pedestal for expanded storage capabilities.		
	ID 48"	ID 42"	ID 36"	ID 42"	ID 72"		ID 66"	ID 60"	
Espresso	25 ALE-VA354824ES	29 ALE-VA354224ES	33 ALE-VA353624ES	37 ALE-VA204224ES	41 ALE-VA257224ES		45 ALE-VA256624ES	49 ALE-VA256024ES	
Mahogany	26 ALE-VA35-4824MY	30 ALE-VA354224MY	34 ALE-VA35-3624MY	38 ALE-VA204224MY	42 ALE-VA25-7224MY		46 ALE-VA256624MY	50 ALE-VA25-6024MY	
Medium Cherry	27 ALE-VA35-4824MC	31 ALE-VA354224MC	35 ALE-VA35-3624MC	39 ALE-VA204224MC	43 ALE-VA25-7224MC		47 ALE-VA256624MC	51 ALE-VA25-6024MC	
Walnut	28 ALE-VA354824WA	32 ALE-VA354224WA	36 ALE-VA353624WA	40 ALE-VA204224WA	44 ALE-VA257224WA		48 ALE-VA256624WA	52 ALE-VA256024WA	
SIZE (W x D x H)	47¼" x 23½" x 29½"	42" x 23½" x 29½"	35" x 23½" x 29½"	41¾" x 23½" x 30"	70¾" x 23½" x 29½"		65" x 23½" x 29½"	59½" x 23½" x 29½"	
SHPG. WT.	83 lbs. 📦 📦	74 lbs. 📦 📦	66 lbs. 📦 📦	99 lbs. 📦	116 lbs. 📦 📦		109 lbs. 📦 📦	102 lbs. 📦 📦	
PRICE	\$275.00	\$260.00	\$235.00	\$345.00	\$375.00		\$365.00	\$335.00	
	Hutch with Doors			Glass Door Set for Hutch		Mobile Box/File Pedestal		Full Pedestal File	
	Fully finished back. Lighting valance and grommets to facilitate task lighting installation. Includes solid hinged doors. Bookcase/Hutch sits on Lateral File as a Cabinet.			Satin metal frame. Hardware included. Frosted glass.		Full-extension ball bearing slides on file drawer.		Full extension drawers. Two fold-away safety keys.	
	ID 72"	ID 66"	ID 60"	ID GLASS FOUR DOOR SETS FOR 72" HUTCH		ID 2 DRAWERS—BOX/FILE	ID 3 DRAWERS—BOX/BOX/FILE	ID 2 DRAWERS—FILE/FILE	
Espresso	53 ALE-VA287215ES	57 ALE-VA286615ES	61 ALE-VA286015ES	65 ALE-VA30-1730		66 ALE-VABFES	70 ALE-VA532822ES	74 ALE-VA542822ES	
Mahogany	54 ALE-VA287215MY	58 ALE-VA286615MY	62 ALE-VA286015MC			67 ALE-VABFMY	71 ALE-VA53-2822MY	75 ALE-VA54-2822MY	
Medium Cherry	55 ALE-VA287215MC	59 ALE-VA286615MC	63 ALE-VA286015MY			68 ALE-VABFMC	72 ALE-VA53-2822MC	76 ALE-VA54-2822MC	
Walnut	56 ALE-VA287215WA	60 ALE-VA286615WA	64 ALE-VA286015WA			69 ALE-VABFWA	73 ALE-VA532822WA	77 ALE-VA542822WA	
SIZE (W x D x H)	70¾" x 15" x 35½"	64¾" x 15" x 35½"	58¾" x 15" x 35½"	17" x 16"		15½" x 19½" x 22½"	15½" x 20½" x 28½"	15½" x 20½" x 28½"	
SHPG. WT.	150 lbs. 📦 📦	139 lbs. 📦 📦	122 lbs. 📦 📦	26 lbs. 📦		55 lbs. 📦	74 lbs. 📦	74 lbs. 📦	
PRICE	\$599.00	\$575.00	\$500.00	\$399.00		\$375.00	\$395.00	\$395.00	



Selection Guide For Alera® Valencia™ Series

	Hanging Pedestal File		Mobile Pedestal File		Reception Desk with Transaction Counter		Reversible Reception Return		Tackboard for Storage Hutch		Under-Counter File Organizer			
	Locking drawers with fold-away safety keys.		Five casters, two locking.		Two grommets. Includes 1" thick bow front transaction counter. 29½" high worksurface.		Adapts to right- or left-handed configurations. 29½" high worksurface.		Cloth-covered tack board. Includes mounting hardware.		Use on desk or under reception counters.			
	ID 2 DRAWERS—BOX/BOX/FILE		ID 3 DRAWERS—BOX/BOX/FILE		ID 2 DRAWERS—FILE/FILE		ID		ID FOR 66" OR 72" HUTCH		ID			
Espresso	1 ALE-VA552222ES		5 ALE-VA572816ES		9 ALE-VA582816ES		13 ALE-VA327236ES		17 ALE-VA324424ES		22 ALE-VA316012ES			
Mahogany	2 ALE-VA55-2222MY		6 ALE-VA572816MY		10 ALE-VA582816MY		14 ALE-VA327236MY		18 ALE-VA324424MY		23 ALE-VA31-6012MY			
Medium Cherry	3 ALE-VA55-2222MC		7 ALE-VA572816MC		11 ALE-VA582816MC		15 ALE-VA327236MC		19 ALE-VA324424MC		24 ALE-VA31-6012MC			
Walnut	4 ALE-VA552222WA		8 ALE-VA572816WA		12 ALE-VA582816WA		16 ALE-VA327236WA		20 ALE-VA324424WA		25 ALE-VA316012WA			
SIZE (W × D × H)	15¾" × 20½" × 19¼"		15¾" × 20½" × 28¾"		15¾" × 20" × 26¾"		71" × 35½" × 42½"		44" × 23¾" × 41½"		15¾" × 10" × 11"			
SHPG. WT.	52 lbs. 📦		77 lbs.		68 lbs.		202 lbs. 📦 📦		96 lbs. 📦 📦		16 lbs. 📦			
PRICE	335.00		459.00		459.00		735.00		385.00		199.00			
	Wardrobe		Round Conference Tables		Low File Cabinet Credenza		Low Storage Cabinet Credenza		Seat Cushion		Center Drawer			
	Commercial-grade laminate panels are water-, scratch- and stain-resistant. Shelf adjusts to customize the storage.		A popular style for quick-huddle setups or any conference room. Straight leg X-base included. Woodgrain Laminate top.		Leveling glides compensate for uneven floors. Two fold-away safety keys. Accommodates letter or legal filing. Add seat cushion to expand seating space.		Sliding doors are removable. Add a coordinated cushion top to expand your seating space.				Mounts under any desk, credenza, return or bridge in the Valencia Series.			
	ID 42"		ID 42" DIAMETER—SEATS 4 PEOPLE.		ID 29½" WIDE FILES		ID		ID PEDESTAL FILE SEAT CUSHION		ID 24½" WIDE			
Espresso	26 ALE-VA621224ES		30 ALE-VA7142ES		34 ALE-LS583020ES		38 ALE-LS593020ES		42 ALE-PC1511		44 ALE-VA312414ES			
Mahogany	27 ALE-VA621224MY		31 ALE-VA7142MY		35 ALE-LS583020MY		39 ALE-LS593020MY		43 ALE-PC1551		45 ALE-VA312414MY			
Medium Cherry	28 ALE-VA621224MC		32 ALE-VA7142MC		36 ALE-LS583020MC		40 ALE-LS593020MC				46 ALE-VA312414MC			
Walnut	29 ALE-VA621224WA		33 ALE-VA7142WA		37 ALE-LS583020WA		41 ALE-LS593020WA				47 ALE-VA312414WA			
Smoke									ww					
Tan Quartz														
SIZE (W × D × H)	117¾" × 23¾" × 65"		42" dia. × 29½"		29½" × 19½" × 22¾"		29½" × 19½" × 22¾"		29½" × 19½" × 2½"		24½" × 15" × 2"			
SHPG. WT.	97 lbs. 📦		80 lbs. 📦		95 lbs. 📦		65 lbs. 📦		17 lbs. 🌱 🌱		9 lbs. 📦			
PRICE	435.00		435.00		495.00		440.00		87.00		99.00			
	Lateral File		Storage Cabinet		Bookcase									
	Locking drawers with fold-away safety keys.		Adjustable shelf. Locking doors with fold-away safety keys. Black metal handles. Freestanding.		Commercial-grade side panels with protective 3 mm edge banding. 11¼" deep shelves. Full-finished solid panel back.									
	ID 34" WIDE FILES		ID		ID SIX SHELVES		ID FIVE SHELVES		ID FOUR SHELVES		ID THREE SHELVES		ID TWO SHELVES	
Espresso	48 ALE-VA513622ES		52 ALE-VA613622ES		56 ALE-VA638232ES		60 ALE-VA636632ES		64 ALE-VA635632ES		68 ALE-VA634432ES		72 ALE-VA633032ES	
Mahogany	49 ALE-VA51-3622MY		53 ALE-VA61-3622MY		57 ALE-VA63-8232MY		61 ALE-VA63-6632MY		65 ALE-VA63-5632MY		69 ALE-VA63-4432MY		73 ALE-VA63-3032MY	
Medium Cherry	50 ALE-VA51-3622MC		54 ALE-VA61-3622MC		58 ALE-VA63-8232MC		62 ALE-VA63-6632MC		66 ALE-VA63-5632MC		70 ALE-VA63-4432MC		74 ALE-VA63-3032MC	
Walnut	51 ALE-VA513622WA		55 ALE-VA613622WA		59 ALE-VA638232WA		63 ALE-VA636632WA		67 ALE-VA635632WA		71 ALE-VA634432WA		75 ALE-VA633032WA	
SIZE (W × D × H)	34" × 22¾" × 29½"		34" × 22¾" × 29½"		31¾" × 14" × 80¾"		31¾" × 14" × 65"		31¾" × 14" × 55"		31¾" × 14" × 39¾"		31¾" × 14" × 29½"	
SHPG. WT.	142 lbs. 📦		115 lbs. 📦 📦		151 lbs. 📦 📦		129 lbs. 📦 📦		109 lbs. 📦 📦		82 lbs. 📦 📦		63 lbs. 📦 📦	
PRICE	615.00		525.00		525.00		411.00		350.00		289.00		265.00	
	Underdesk Keyboard/Mouse Shelf		Under Cabinet LED Lamp		Core Removable Lock and Key Set		Polycarbonate Privacy Panel							
	¾" thick. Black.		Frame swivels 360° for quick re-direction. Includes AC adapter with 70" long cord and mounting hardware kit.		Two fold away safety keys and one lock core included.		Divides workspaces, but allows light to pass through. Secure clip-on attachment.							
	ID		ID		ID		ID 48" WIDE		ID 66" WIDE					
Espresso	76 ALE-VA312812BK		77 ALE-LEDUC24B		78 ALE-VA50-1111		79 ALE-PP4718		80 ALE-PP6518					
SIZE (W × D × H)	10"		24" × 2"		6 lbs.		47" × ½" × 18"		65" × ½" × 18"					
SHPG. WT.	13 lbs. 📦		25 lbs. 📦		22.00		8 lbs.		9 lbs. 📦					
PRICE	87.00		86.00				190.00		249.00					

20-MF-L-FCL



# Foundation™ Laminate Desks

Create a solid starting point for your success with HON Foundation.

- Personalize your office suite with this versatile collection of laminate desk and storage solutions that can be combined in a variety of ways to fit any work style or space.
- Lateral files and storage pedestals come fully assembled, and desk and credenzas assemble easily in minutes.
- Get the fundamentals and much more with the HON Foundation laminate collection.
- Backed by the HON Limited Five-Year Warranty.
- Meets or Exceeds ISTA Performance Standards.



Typicals can be reconfigured for left- or right-handed applications.

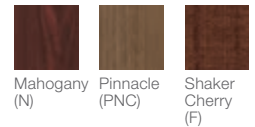

## Selection Guide For Foundation™ Laminate Desks

Mahogany Pinnacle Shaker Cherry SIZE (W x D x H) SHPG. WT. PRICE	<p><b>Breakfront Desk Shell Bow Front</b></p> <p>Breakfront design creates a high end aesthetic for private offices and executive workstations. Bow front provides guests with increased work surface space. Scratch-, spill- and stain-resistant laminate stands up to heavy use.</p> <p>ID 1 HON-LM7242BFN 2 HON-LM7242BFPNC 3 HON-LM7242BFF 72" x 42" x 29" 157 lbs.   478.00</p>	<p><b>Reception Station with Bow Front</b></p> <p>Stack-on component mounts to a desk to create space for greeting visitors. Convenient transaction top allows visitors to stand while conducting business.</p> <p>ID 4 HON-LMRECPN 5 HON-LMRECPPNC 6 HON-LMRECPF 72" x 36" x 14 1/4" 75 lbs.   322.00</p>	<p><b>Breakfront Desk Shell</b></p> <p>Breakfront design creates a high end aesthetic for private offices and executive workstations. Scratch-, spill- and stain-resistant laminate stands up to heavy use.</p> <p>ID 7 HON-LM7236BFN 8 HON-LM7236BFPNC 9 HON-LM7236BFF 72" x 36" x 29" 152 lbs.   426.00</p>	<p><b>Bow Top Desk Shell</b></p> <p>Non-handed desk shell can be combined with a return shell to create an L-workstation. Straightforward styling blends with any office design.</p> <p>ID 10 HON-LM7242N 11 HON-LM7242PNC 12 HON-LM7242F 72" x 42" x 29" 154 lbs.   384.00</p>
	<p><b>Credenza Shell</b></p> <p>Straightforward styling blends with any office design. Scratch-, spill- and stain-resistant laminate stands up to heavy use. Desktop grommets help to organize power and data cables on the work surface.</p> <p>ID 72" ID 60" 13 HON-LM72CRDN 16 HON-LM60CRDN 14 HON-LM72CRDPNC 17 HON-LM60CRDPNC 15 HON-LM72CRDF 18 HON-LM60CRDF 72" x 24" x 29" 60" x 24" x 29" 108 lbs.   96 lbs.   270.00 240.00</p>	<p><b>Rectangle Top Desk Shell</b></p> <p>Non-handed desk shell can be combined with a return shell to create an L-workstation. To create a U-workstation, order credenza shell and on-handed bridge.</p> <p>ID 72" ID 66" ID 60" 19 HON-LM7236N 22 HON-LM6630N 25 HON-LM6030N 20 HON-LM7236PNC 23 HON-LM6630PNC 26 HON-LM6030PNC 21 HON-LM7236F 24 HON-LM6630F 27 HON-LM6030F 72" x 36" x 29" 66" x 30" x 29" 60" x 30" x 29" 149 lbs.   116 lbs.   112 lbs.   334.00 287.00 263.00</p>	<p><b>Bridge</b></p> <p>Non-handed bridge can be combined with a desk shell and a credenza shell to create a U-workstation. Full-height modesty panel adds privacy; unit can be installed with or without the modesty panel. Includes one 3" diameter work surface grommet for easy cord management.</p> <p>ID 28 HON-LM48BRGN 29 HON-LM48BRGPNC 30 HON-LM48BRGF 47 3/4" x 23.88" x 28.44" 53 lbs.   197.00</p>	
<p><b>Reception Station - For Returns</b></p> <p>Stack-on component extends the reception station onto a return to create space for greeting visitors.</p> <p>ID 31 HON-LMRECPRETN 32 HON-LMRECPRETNPNC 33 HON-LMRECPRETF 42 1/4" x 24" x 13" 28 lbs.   139.00</p>	<p><b>Return Shell</b></p> <p>Non-handed return shell can be combined with a non-handed desk, or credenza shell to create an L-workstation.</p> <p>ID 48" ID 42" 34 HON-LM48RETN 37 HON-LM42RETN 35 HON-LM48RETPNC 38 HON-LM42RETPNC 36 HON-LM48RETF 39 HON-LM42RETF 48 1/4" x 24" x 29" 42 1/4" x 24" x 29" 67 lbs.   67 lbs.   208.00 192.00</p>	<p><b>Corner Unit</b></p> <p>Helps maximize office footprints by taking advantage of often underutilized spaces. Scratch-, spill- and stain-resistant laminate stands up to heavy use.</p> <p>ID 40 HON-LM42CUN 41 HON-LM42CUPNC 42 HON-LM42CUF 36" x 36" x 29" 115 lbs.   386.00</p>	<p><b>Peninsula with End Panel</b></p> <p>Non-handed peninsula can be combined with a left or right return to create an L-workstation.</p> <p>ID 43 HON-LM72PENN 44 HON-LM72PENPNC 45 HON-LM72PENF 72" x 36" x 29" 117 lbs.   432.00</p>	



Shown in Pinnacle with HON Coordinate™ Height Adjustable Desk Base and HON Convergence® seating.



Shown in Mahogany with HON Traction™ seating.

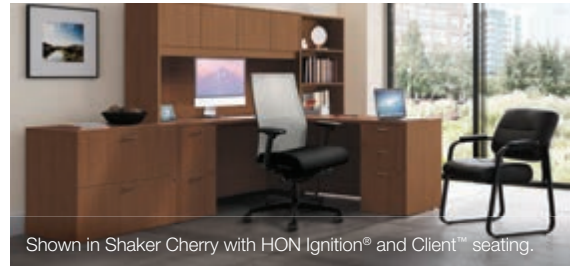

Shown in Shaker Cherry with HON Ignition® and Client™ seating.

## Selection Guide For Foundation™ Laminate Desks

Mahogany Pinnacle Shaker Cherry SIZE (W × D × H) SHPG. WT. PRICE	<b>Hutch with Doors</b>  Can be mounted to any base unit of the same size. Designed to be installed on top of a desk or credenza; not intended to be used freestanding on the floor.	<b>Personal Wardrobe Cabinet</b>  Conveniently stores coats, purses and other personal belongings. Shelf adjusts in 1" increments to customize the storage area to the user's needs.	<b>Bookcases</b>  Five-shelves handle all your books and reference materials. Fully enclosed back is finished on both sides, so this cabinet can be used as a room divider.	<b>Lateral File</b>  Accommodates the largest volume of filing in an efficient format that saves floorspace. Features ball-bearing drawer suspensions.			
	ID 72"      ID 60" 1 HON-LM72HUTN      4 HON-LM60HUTN 2 HON-LM72HUTPNC      5 HON-LM60HUTPNC 3 HON-LM72HUTF      6 HON-LM60HUTF 72" × 14.63" × 37.13"      60" × 14.63" × 37.13" 139 lbs.         119 lbs. 464.00      420.00	ID 7 HON-LMPWCN 8 HON-LMPWCPNC 9 HON-LMPWCF 18" × 24" × 66" 84 lbs. 547.00	ID 5 SHELVES 10 HON-LM65BCN 11 HON-LM65BCPNC 12 HON-LM65BCF 32.06" × 13.81" × 65.38" 138 lbs. 304.00	ID 13 HON-LMLATFN 14 HON-LMLATFPNC 15 HON-LMLATFF 35.779" × 19 1/8" × 28.48" 145 lbs. 542.00			
Mahogany Pinnacle Shaker Cherry SIZE (W × D × H) SHPG. WT. PRICE	<b>Pedestal File</b>  Put the most important documents, supplies, and personal items within easy reach. Fully assembled and ready to use; no need to fasten to desk shell.	<b>Round Conference Table</b>  Comfortably seats up to five people. The base has adjustable leveling glides to compensate for uneven floors. Table top and base are packaged together for convenient installation. Thermal Fused Laminate (TFL) top.	<b>Rectangular Conference Table</b>  Comfortably seats up to six people and sits atop a panel base, which has adjustable leveling glides to compensate for uneven floors. Table top and base are packaged together for convenient installation. Thermal Fused Laminate (TFL) top.	<b>¾ Hanging Pedestal File</b>  This modular pedestal is mounted to a desk, return or credenza shell. Pedestals bring the most important documents, supplies, and personal items within easy reach.			
	ID BOX/BOX/FILE      ID FILE/FILE 16 HON-LMBBFN      19 HON-LMFFN 17 HON-LMBBFPNC      20 HON-LMFFPNC 18 HON-LMBBFF      21 HON-LMFFF 15.415" × 20.41" × 27.832"      15.415" × 20.41" × 27.832" 81 lbs.         79 lbs. 334.00      334.00	ID 22 HON-LMC48DN 23 HON-LMC48DPNC 24 HON-LMC48DF 47" dia. × 29 1/2" 88 lbs. 302.00	ID 25 HON-LMC72RN 26 HON-LMC72RPNC 27 HON-LMC72RF 72" × 36" × 29 1/2" 128 lbs. 367.00	ID 28 HON-LMBFN 29 HON-LMBFPNC 30 HON-LMBFF 15.415" × 20.41" × 20.583" 64 lbs. 257.00			
Mahogany Pinnacle Shaker Cherry SIZE (W × D × H) SHPG. WT. PRICE	<b>Hutch Doors</b>  Frosted glass elevates the aesthetic and allows natural light to pass through. Scratch-, spill- and stain-resistant laminate door frames stand up to heavy use. Metal-to-metal fastening system for precise fit and unsurpassed durability.	<b>Frosted Glass Modesty Panel</b>  Frosted glass increases privacy while allowing natural light to pass through. Designed to support 72" wide BL Series breakfront desk shells.	<b>Field Installed Bridge Pull</b>  Modern aesthetic complements BL Laminated storage. Polished silver finish. Sold in packs of 2.	<b>Field Installed Contemporary Pull</b>  Modern aesthetic complements BL Laminated storage. Polished silver finish. Sold in packs of 2.	<b>Field Installed Classic Pull</b>  Classic pull for matching legacy BL Laminated storage. Black finish. Sold in packs of 2.	<b>USB AC Power Hub</b>  Fits 3" grommet holes. One grounded AC outlet. Two USB ports. 6 ft. power cord. Backed by the HON Full Lifetime Warranty.	<b>AC Power Hub</b>  Fits 3" grommet holes. Two grounded AC outlets. 6 ft. power cord. Backed by the HON Full Lifetime Warranty.
	ID 31 BSX-BL72HDG 13 3/4" × 17 1/8" 9 lbs. 390.00	ID 32 BSX-BLBF72MODG 39 1/2" × 27 1/4" 18 lbs. 257.00	ID 33 BSX-BLPBRIDGE 1 lb. 12.00	ID 34 BSX-BLPCONTEMP 1 lb. 12.00	ID 35 BSX-BLPCLASSIC 1 lb. 12.00	ID 36 HON-HGRMTUSB2 3.4"w × 3.4"d × 3.4"h × 6'f 2 lbs. 219.00	ID 37 HON-GRMTACX 3"w × 3"d 1 lb. 111.00

20-MF-L-FCL





## Enterprise Collection

Transitional styling that creates a professional impression anywhere.

- Cost-effective solution with integrated technology features ideal for small office or at home.
- Storage options improve work-in-process organization to keep you on task.
- 4-port USB hub in all desk surfaces connects electronic devices to your laptop.
- Factory assembled hutches and pedestals simplify installation.
- Manufacturer's ten-year warranty.
- Contains 5% post-consumer recycled content, 50% total recycled content.
- Meets or Exceeds ANSI/BIFMA Standards.



Harvest Cherry (CS)



Mocha Cherry (MC)

## Selection Guide For Enterprise Collection

### L-Desk

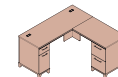
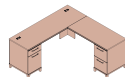

Locking pedestals include wire management and full-extension drawers. Desk and Pedestals sold and shipped separately--ORDER BOTH.

#### ID 72" DESK SURFACE & MODESTY PANEL

1 BSH-2910CSA2-03  
2 BSH-2910MCA2-03  
70 1/8" x 70 1/8" x 29 3/4"  
114 lbs.   
707.00

#### ID PEDESTAL FOR 72" DESK

3 BSH-2910CSA1-03  
4 BSH-2910MCA1-03  
70 1/8" x 70 1/8" x 29 3/4"  
135 lbs.   
707.00

#### ID 60" DESK SURFACE & MODESTY PANEL

5 BSH-2930CSA2-03  
6 BSH-2930MCA2-03  
60" x 60" x 29 3/4"  
106 lbs.   
638.50

#### ID PEDESTAL FOR 60" DESK

7 BSH-2930CSA1-03  
8 BSH-2930MCA1-03  
60" x 60" x 29 3/4"  
135 lbs.   
638.50

Harvest Cherry  
Mocha Cherry  
SIZE (W x D x H)  
SHPG. WT.  
PRICE

### Double Pedestal Desk



Locking pedestals; compartment with door can accommodate CPU. Desk and Pedestals sold and shipped separately--ORDER BOTH.

#### ID 72" DESK

9 BSH-2972CSA2-03  
10 BSH-2972MCA2-03  
70 1/8" x 28 3/8" x 29 3/4"  
93 lbs.   
682.00

#### ID PEDESTAL FOR 72" DESK

11 BSH-2972CSA1-03  
12 BSH-2972MCA1-03  
70 1/8" x 28 3/8" x 29 3/4"  
148 lbs.   
682.00

#### ID 60" DESK

13 BSH-2960CSA2-03  
14 BSH-2960MCA2-03  
60" x 28 3/8" x 29 3/4"  
64 lbs.   
615.50

#### ID PEDESTAL FOR 60" DESK

15 BSH-2960CSA1-03  
16 BSH-2960MCA1-03  
60" x 28 3/8" x 29 3/4"  
135 lbs.   
615.50

Harvest Cherry  
Mocha Cherry  
SIZE (W x D x H)  
SHPG. WT.  
PRICE

### Corner Desk



Desk features a Box/Box/File pedestal. Micro hutch can mount in multiple locations and contains one charging station. Fabric covered taskboard included. Desk and Pedestals sold and shipped separately--ORDER BOTH.

#### ID DESK

17 BSH-2999CSA2-03  
18 BSH-2999MCA2-03  
60" x 47 1/4" x 41 3/4"  
120 lbs.   
616.50

#### ID PEDESTAL

19 BSH-2999CSA1-03  
20 BSH-2999MCA1-03  
60" x 47 1/4" x 41 3/4"  
65 lbs.   
616.50

### Low Hutch



Two sliding doors. Four storage areas with two adjustable shelves. Pre-installed taskboard. Fits on 60" Double Pedestal Desk or 60" L-Desk. Shelves adjust in 1/4" increments.

#### ID

21 BSH-2961CS-03  
22 BSH-2961MC-03

Harvest Cherry  
Mocha Cherry  
SIZE (W x D x H)  
SHPG. WT.  
PRICE

60" x 12 3/8" x 27 3/4"  
101 lbs.   
789.00

### Lateral File



Locking top drawer. Safety interlock device allows only one drawer to be open at a time.

#### ID 30" WIDE FILES--TWO-DRAWER

23 BSH-2954CS-03  
24 BSH-2954MC-03  
30" x 23 1/8" x 29 3/4"  
125 lbs.   
789.00

### Multi-Purpose Drawer



For use with all Enterprise desks. Drawer front flips down for use as a wrist rest when using a keyboard. Ventilated bottom.

#### ID

25 BSH-AC99855-03  
27 1/8" x 17 3/8" x 3 3/8"  
17 lbs.   
258.00



# Series C Collection

Clean lines, extended modesty panels and Brushed Nickel hardware create a classic, professional look.

- Numerous desk sizes and configurations fit the needs of offices large and small.
- Closed storage solutions include Mobile Pedestals and locking cabinets for your convenience and security.
- Hutches include open and closed storage, fabric tack boards and fully finished back panels.
- Attractive Bow Front Desks provide added workspace for guests to pull up a chair and take notes.
- Factory assembled pedestals simplify installation.
- Manufacturer's ten-year warranty.
- Contains 5% post-consumer recycled content, 50% total recycled content.
- Level 1 Certified; Meets or Exceeds ANSI/BIFMA Standards.



Hansen Cherry/  
Graphite Gray  
(244)



Natural Cherry/  
Graphite Gray  
(724)

## Selection Guide For Series C Collection

H. Cherry/G. Gray N. Cherry/G. Gray SIZE (W x D x H) SHPG. WT. PRICE	<b>Bow Front Desk Shell</b>  Use alone or with Return Bridge and Credenza for a "U" workstation. ID 1 BSH-WC24446 2 BSH-WC72446 71 <sup>1</sup> / <sub>8</sub> " x 36 <sup>1</sup> / <sub>2</sub> " x 29 <sup>7</sup> / <sub>8</sub> " 142 lbs. 593.00	<b>Desk Shell</b>  Use alone or with Return Bridge and Credenza for a "U" workstation. ID <b>72" WIDE</b> 3 BSH-WC24436 4 BSH-WC72436 71 <sup>1</sup> / <sub>8</sub> " x 29 <sup>3</sup> / <sub>8</sub> " x 29 <sup>7</sup> / <sub>8</sub> " 136 lbs. 527.00	<b>Corner Desk Module</b>  Use with Bow Front Desk or Rectangular Desk and Lateral File for a "U" workstation. ID <b>RIGHT</b> 7 BSH-WC24423 8 BSH-WC72423 71 <sup>1</sup> / <sub>8</sub> " x 35 <sup>1</sup> / <sub>2</sub> " x 29 <sup>7</sup> / <sub>8</sub> " 135 lbs. 598.00	ID <b>LEFT</b> 9 BSH-WC24432 10 BSH-WC72432 71 <sup>1</sup> / <sub>8</sub> " x 35 <sup>1</sup> / <sub>2</sub> " x 29 <sup>7</sup> / <sub>8</sub> " 135 lbs. 598.00	
	<b>Return Bridge</b>  Use on left or right side of Bow Front Desk or Rectangular Desk for "L" Workstation. Add a Credenza for a "U" workstation. ID 11 BSH-WC24424 12 BSH-WC72424 47 <sup>3</sup> / <sub>4</sub> " x 23 <sup>3</sup> / <sub>8</sub> " x 29 <sup>7</sup> / <sub>8</sub> " 79 lbs. 288.00	<b>Credenza Shell</b>  Use freestanding or combine with Return Bridge to create an "L" workstation; use with Desk and Return/Bridge to form a "U" workstation. ID 13 BSH-WC24426 14 BSH-WC72426 71 <sup>1</sup> / <sub>8</sub> " x 23 <sup>3</sup> / <sub>8</sub> " x 29 <sup>7</sup> / <sub>8</sub> " 115 lbs. 494.00	<b>Hutch with Two Doors</b>  Fits on top of Credenza, Corner Module or two Lateral Files. Six sorter compartments under storage area. Full-width tackboard. ID <b>CARTON 1</b> 15 BSH-WC24466A1 16 BSH-WC72466A1 71 <sup>1</sup> / <sub>8</sub> " x 15 <sup>3</sup> / <sub>8</sub> " x 43 <sup>1</sup> / <sub>8</sub> " 126 lbs. 405.00	ID <b>CARTON 2</b> 17 BSH-WC24466A2 18 BSH-WC72466A2 71 <sup>1</sup> / <sub>8</sub> " x 15 <sup>3</sup> / <sub>8</sub> " x 43 <sup>1</sup> / <sub>8</sub> " 52 lbs. 404.00	<b>Hutch with Four Doors</b>  Fits on top of Credenza, Corner Module or two Lateral Files. Six sorter compartments under storage area. Full-width tackboard. ID <b>CARTON 1</b> 19 BSH-WC24477A1 20 BSH-WC72477A1 71 <sup>1</sup> / <sub>8</sub> " x 15 <sup>3</sup> / <sub>8</sub> " x 43 <sup>1</sup> / <sub>8</sub> " 128 lbs. 405.00
H. Cherry/G. Gray N. Cherry/G. Gray SIZE (W x D x H) SHPG. WT. PRICE	<b>Bookcase</b>  Five shelves, three adjustable. ID <b>5-SHELF WIDE BOOKSHELF</b> 23 BSH-WC24414 24 BSH-WC72414 35 <sup>5</sup> / <sub>8</sub> " x 15 <sup>3</sup> / <sub>8</sub> " x 72 <sup>1</sup> / <sub>2</sub> " 109 lbs. 427.00	ID <b>5-SHELF NARROW BOOKSHELF</b> 25 BSH-WC24412 26 BSH-WC72412 17 <sup>7</sup> / <sub>8</sub> " x 15 <sup>3</sup> / <sub>8</sub> " x 72 <sup>1</sup> / <sub>2</sub> " 89 lbs. 314.00	<b>Storage Cabinet</b>  One adjustable shelf. Rear wire access opening. Adjustable levelers. Locks for privacy. ID 27 BSH-WC24496A 28 BSH-WC72496A 29 <sup>1</sup> / <sub>2</sub> " x 23 <sup>3</sup> / <sub>8</sub> " x 29 <sup>7</sup> / <sub>8</sub> " 97 lbs. 428.00	<b>Two-Drawer Lateral File</b>  Two drawers accommodate letter/legal size hanging files. Full-extension ball bearing slides. Lock. ID <b>35<sup>3</sup>/<sub>4</sub>" WIDE FILES</b> 29 BSH-WC24454ASU 30 BSH-WC72454ASU 35 <sup>3</sup> / <sub>4</sub> " x 23 <sup>3</sup> / <sub>8</sub> " x 29 <sup>7</sup> / <sub>8</sub> " 145 lbs. 818.00	<b>Three-Drawer Mobile Pedestal File</b>  Two box, one file drawer. Accommodates letter/legal size hanging files. Lock. Casters. ID <b>3 DRAWERS—BOX/BOX/FILE</b> 31 BSH-WC24453SU 32 BSH-WC72453SU 15 <sup>3</sup> / <sub>4</sub> " x 20 <sup>1</sup> / <sub>4</sub> " x 27 <sup>1</sup> / <sub>2</sub> " 66 lbs. 508.00
	<b>Universal Pencil Drawer</b>  Routed groove holds pens and pencils. Metal slides provide easy opening and closing. 33 BSH-AC99850 26 <sup>1</sup> / <sub>16</sub> " x 15 <sup>7</sup> / <sub>8</sub> " x 2 <sup>3</sup> / <sub>4</sub> " 11 lbs. 196.00	<b>Articulating Keyboard Platform</b>  Accommodates keyboard and mouse. Galaxy finish. 34 BSH-AC99801-03 17" 13 lbs. 319.00	<b>Light Pack</b>  Attaches to underside of overhead. Includes 13W 21" T5 cool white fluorescent bulb. 8 ft. cord. 2 prong. 35 BSH-WC8065A-03 23 <sup>3</sup> / <sub>8</sub> " x 3 <sup>1</sup> / <sub>2</sub> " 3 lbs. 148.00		

20-MF-L-FCL

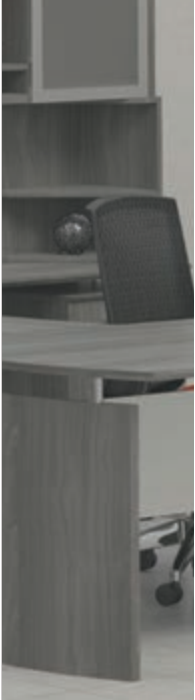

# Medina™ Laminate Series

Combines Italian-influenced designs, style and durability with economical pricing.



Gray Steel

- All desk, return and extension work surfaces are 1" thick with a distinctive beveled edge.
- Desk surfaces seem to float on silver supports.
- Curved end panels reflect curved ends of worksurfaces.
- Desks have a silver modesty panel.
- Locks are keyed-alike and feature removable cores.
- All floor supported models include steel leveling glides.
- Manufacturer's limited lifetime warranty.
- Intertek Certified.



Silver Modesty Panel.



Silver Stand-off.

Suggested Seating  
 Each ~~459.00~~  
 MLN-3200  
 ID 1  
 Complement your office suite with the Mercado™ Mid-Back Fabric/  
 Mesh Chair.



Preferred Settings

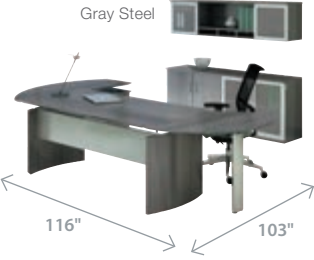

**Desk Suite 7,180.00**

Qty.	Item No.	Description
1	MLN-MNDT72LGS	<b>72" Desk (Top)</b>
1	MLN-MNDBLGS	<b>72" Desk (Base)</b>
1	MLN-MNEXTRLGS	<b>Curved Desk Extension Right</b>
1	MLN-MNRTNLLGS	<b>Curved Desk Return Left Hand</b>
1	MLN-MNBFPPLGS	<b>P/B/F Pedestal for Return</b>
1	MLN-MVLCCLGS	<b>Low Wall Cabinet (Cabinet)</b>
1	MLN-MVLCDLGS	<b>Low Wall Cabinet (Doors)</b>
2	MLN-MGDCLGS	<b>Glass Display Cabinet</b>
2	MLN-MSCLGS	<b>Storage Cabinet</b>

**Desk Suite 4,277.00**

Qty.	Item No.	Description
1	MLN-MNDT72LGS	<b>72" Desk (Top)</b>
1	MLN-MNDBLGS	<b>72" Desk (Base)</b>
1	MLN-MNEXTLGLS	<b>Curved Desk Extension Left</b>
1	MLN-MNRTNRLGS	<b>Curved Desk Return Right Hand</b>
1	MLN-MNBFPPLGS	<b>P/B/F Pedestal for Return</b>
1	MLN-MVLCCLGS	<b>Low Wall Cabinet (Cabinet)</b>
1	MLN-MVLCDLGS	<b>Low Wall Cabinet (Doors)</b>
1	MLN-MNH72LGS	<b>Hutch</b>

**Desk Suite 5,128.00**

Qty.	Item No.	Description
1	MLN-MNDT72LGS	<b>72" Desk (Top)</b>
1	MLN-MNDBLGS	<b>72" Desk (Base)</b>
1	MLN-MNEXTLGLS	<b>Curved Desk Extension Left</b>
1	MLN-MNBDBGRLGS	<b>Right Hand Bridge</b>
1	MLN-MNCNZ72LGS	<b>72" Credenza</b>
1	MLN-MVLCCLGS	<b>Low Wall Cabinet (Cabinet)</b>
1	MLN-MVLCDLGS	<b>Low Wall Cabinet (Doors)</b>
1	MLN-MNH72LGS	<b>Hutch</b>
2	MLN-MNPOLGS	<b>Hutch Supports</b>
2	MLN-MVBQ2LGS	<b>Two-Shelf Quarter Round</b>

Selection Guide For Medina™ Laminate Series



<p>Gray Steel SIZE (W x D x H) SHPG. WT. PRICE</p>	<p><b>Curved Desk</b></p> <p>Top and Base sold and shipped separately—ORDER BOTH.</p> <table border="1"> <tr> <td>ID BOX 1 OF 2 (BASE)</td> <td>ID BOX 2 OF 2 (TOP)</td> </tr> <tr> <td>1 MLN-MNDBLGS 72" x 36" x 29½"</td> <td>2 MLN-MNDT72LGS 72" x 36" x 29½"</td> </tr> <tr> <td>45 lbs. </td> <td>90 lbs.  </td> </tr> <tr> <td>332.00</td> <td>477.00</td> </tr> </table>	ID BOX 1 OF 2 (BASE)	ID BOX 2 OF 2 (TOP)	1 MLN-MNDBLGS 72" x 36" x 29½"	2 MLN-MNDT72LGS 72" x 36" x 29½"	45 lbs.	90 lbs.	332.00	477.00	<p><b>Curved Return</b></p> <p>Creates L-shaped worksurface when attached to Curved Desk. Requires support by Return Pencil-Box-File Pedestal.</p> <table border="1"> <tr> <td>ID LEFT</td> <td>ID RIGHT</td> </tr> <tr> <td>3 MLN-MNRTNLLGS 63" x 24" x 29½"</td> <td>4 MLN-MNRTNRLGS 63" x 24" x 29½"</td> </tr> <tr> <td>37 lbs.  </td> <td>37 lbs.  </td> </tr> <tr> <td>309.00</td> <td>309.00</td> </tr> </table>	ID LEFT	ID RIGHT	3 MLN-MNRTNLLGS 63" x 24" x 29½"	4 MLN-MNRTNRLGS 63" x 24" x 29½"	37 lbs.	37 lbs.	309.00	309.00	<p><b>Curved Desk Extension</b></p> <p>Exceptional abrasion and stain resistance. Silver curved support adds contemporary look. 1" thick work surface with a distinctive beveled edge. Includes steel threaded leveling guides.</p> <table border="1"> <tr> <td>ID LEFT</td> <td>ID RIGHT</td> </tr> <tr> <td>5 MLN-MNEXTLGLS 47" x 24" x 29½"</td> <td>6 MLN-MNEXTRLGS 47" x 24" x 29½"</td> </tr> <tr> <td>55 lbs. </td> <td>55 lbs. </td> </tr> <tr> <td>490.00</td> <td>490.00</td> </tr> </table>	ID LEFT	ID RIGHT	5 MLN-MNEXTLGLS 47" x 24" x 29½"	6 MLN-MNEXTRLGS 47" x 24" x 29½"	55 lbs.	55 lbs.	490.00	490.00								
	ID BOX 1 OF 2 (BASE)	ID BOX 2 OF 2 (TOP)																																	
1 MLN-MNDBLGS 72" x 36" x 29½"	2 MLN-MNDT72LGS 72" x 36" x 29½"																																		
45 lbs.	90 lbs.																																		
332.00	477.00																																		
ID LEFT	ID RIGHT																																		
3 MLN-MNRTNLLGS 63" x 24" x 29½"	4 MLN-MNRTNRLGS 63" x 24" x 29½"																																		
37 lbs.	37 lbs.																																		
309.00	309.00																																		
ID LEFT	ID RIGHT																																		
5 MLN-MNEXTLGLS 47" x 24" x 29½"	6 MLN-MNEXTRLGS 47" x 24" x 29½"																																		
55 lbs.	55 lbs.																																		
490.00	490.00																																		
<p>Gray Steel SIZE (W x D x H) SHPG. WT. PRICE</p>	<p><b>Bridge</b></p> <p>Not freestanding—Must use with Desk and Credenza.</p> <table border="1"> <tr> <td>ID LEFT</td> <td>ID RIGHT</td> </tr> <tr> <td>7 MLN-MNBDBGLLGS 48" x 24" x 29½"</td> <td>8 MLN-MNBDBGRLGS 48" x 24" x 29½"</td> </tr> <tr> <td>63 lbs. </td> <td>63 lbs. </td> </tr> <tr> <td>405.00</td> <td>405.00</td> </tr> </table>	ID LEFT	ID RIGHT	7 MLN-MNBDBGLLGS 48" x 24" x 29½"	8 MLN-MNBDBGRLGS 48" x 24" x 29½"	63 lbs.	63 lbs.	405.00	405.00	<p><b>Credenza</b></p> <p>Rectangle top supported by silver stand offs.</p> <table border="1"> <tr> <td>ID</td> </tr> <tr> <td>9 MLN-MNCNZ72LGS 72" x 20" x 29½"</td> </tr> <tr> <td>112 lbs.  </td> </tr> <tr> <td>526.00</td> </tr> </table>	ID	9 MLN-MNCNZ72LGS 72" x 20" x 29½"	112 lbs.	526.00	<p><b>Low Wall Cabinet with Doors</b></p> <p>Self-closing hinged doors. One shelf on each side adjusts in 1¼" increments. Two sets of doors lock separately but are keyed alike. Cabinet and Doors sold and shipped separately—ORDER BOTH.</p> <table border="1"> <tr> <td>ID BOX 1 OF 2 (CABINET)</td> <td>ID BOX 2 OF 2 (DOORS)</td> </tr> <tr> <td>10 MLN-MVLCCLGS 72" x 20" x 29½"</td> <td>11 MLN-MVLCDLGS 72" x 20" x 29½"</td> </tr> <tr> <td>141 lbs.  </td> <td>40 lbs. </td> </tr> <tr> <td>829.00</td> <td>346.00</td> </tr> </table>	ID BOX 1 OF 2 (CABINET)	ID BOX 2 OF 2 (DOORS)	10 MLN-MVLCCLGS 72" x 20" x 29½"	11 MLN-MVLCDLGS 72" x 20" x 29½"	141 lbs.	40 lbs.	829.00	346.00	<p><b>Hutch</b></p> <p>This versatile hutch can be wall mounted or sit on corner supports. Frosted glass doors with silver frames enhance the look of this hutch. Ships fully assembled. Laminate provides for exceptional abrasion and stain resistance and provides durability.</p> <table border="1"> <tr> <td>ID</td> </tr> <tr> <td>12 MLN-MNH72LGS 72" x 15" x 18¼"</td> </tr> <tr> <td>120 lbs. </td> </tr> <tr> <td>937.00</td> </tr> </table>	ID	12 MLN-MNH72LGS 72" x 15" x 18¼"	120 lbs.	937.00							
ID LEFT	ID RIGHT																																		
7 MLN-MNBDBGLLGS 48" x 24" x 29½"	8 MLN-MNBDBGRLGS 48" x 24" x 29½"																																		
63 lbs.	63 lbs.																																		
405.00	405.00																																		
ID																																			
9 MLN-MNCNZ72LGS 72" x 20" x 29½"																																			
112 lbs.																																			
526.00																																			
ID BOX 1 OF 2 (CABINET)	ID BOX 2 OF 2 (DOORS)																																		
10 MLN-MVLCCLGS 72" x 20" x 29½"	11 MLN-MVLCDLGS 72" x 20" x 29½"																																		
141 lbs.	40 lbs.																																		
829.00	346.00																																		
ID																																			
12 MLN-MNH72LGS 72" x 15" x 18¼"																																			
120 lbs.																																			
937.00																																			
<p>Gray Steel SIZE (W x D x H) SHPG. WT. PRICE</p>	<p><b>Glass Display Cabinet</b></p> <p>Self-closing hinged doors. Tempered glass for safety. Two shelves adjust in 1¼" increments.</p> <table border="1"> <tr> <td>ID</td> </tr> <tr> <td>13 MLN-MGDCLGS 36" x 20" x 39¼"</td> </tr> <tr> <td>111 lbs.  </td> </tr> <tr> <td>1,083.00</td> </tr> </table>	ID	13 MLN-MGDCLGS 36" x 20" x 39¼"	111 lbs.	1,083.00	<p><b>Storage Cabinet</b></p> <p>Self-closing hinged doors. One shelf adjusts in 1¼" increments.</p> <table border="1"> <tr> <td>ID</td> </tr> <tr> <td>14 MLN-MSCLGS 36" x 20" x 29½"</td> </tr> <tr> <td>91 lbs. </td> </tr> <tr> <td>837.00</td> </tr> </table>	ID	14 MLN-MSCLGS 36" x 20" x 29½"	91 lbs.	837.00	<p><b>Hutch Support</b></p> <p>Helps take your wall-mounted hutch off the wall to use it on your desk or credenza. Contains two open compartment slots. Ships fully assembled. Two corner supports are needed to support a hutch.</p> <table border="1"> <tr> <td>ID</td> </tr> <tr> <td>15 MLN-MNPOLGS 15" x 15" x 20"</td> </tr> <tr> <td>22 lbs.</td> </tr> <tr> <td>132.00</td> </tr> </table>	ID	15 MLN-MNPOLGS 15" x 15" x 20"	22 lbs.	132.00	<p><b>Two-Shelf Quarter Round Bookcase</b></p> <p>Open shelves for convenient storage.</p> <table border="1"> <tr> <td>ID 2 SHELVES</td> </tr> <tr> <td>16 MLN-MVBQ2LGS 20" x 20" x 29½"</td> </tr> <tr> <td>37 lbs. </td> </tr> <tr> <td>261.00</td> </tr> </table>	ID 2 SHELVES	16 MLN-MVBQ2LGS 20" x 20" x 29½"	37 lbs.	261.00	<p><b>Conference Table</b></p> <p>250 lb weight capacity. MDF, Laminate top Supports up to 250 lbs. evenly distributed.</p> <table border="1"> <tr> <td>ID</td> </tr> <tr> <td>17 MLN-MNCR48LGS 48" dia. x 29½"</td> </tr> <tr> <td>90 lbs.  </td> </tr> <tr> <td>720.00</td> </tr> </table>	ID	17 MLN-MNCR48LGS 48" dia. x 29½"	90 lbs.	720.00	<p><b>Five-Shelf Bookcase</b></p> <p>Open shelves for convenient storage.</p> <table border="1"> <tr> <td>ID 5 SHELVES</td> </tr> <tr> <td>18 MLN-MVB5LGS 36" x 13" x 68"</td> </tr> <tr> <td>146 lbs.  </td> </tr> <tr> <td>707.00</td> </tr> </table>	ID 5 SHELVES	18 MLN-MVB5LGS 36" x 13" x 68"	146 lbs.	707.00	<p><b>Pedestal</b></p> <p>Locks are keyed-alike and feature removable cores. Drawers operate smoothly using full-extension ball-bearing suspensions. Accommodate letter and legal files. Drawer interiors are finished to match the exterior.</p> <table border="1"> <tr> <td>ID 3 DRAWERS</td> </tr> <tr> <td>19 MLN-MNBFPPLGS 15½" x 18¼" x 26¾"</td> </tr> <tr> <td>74 lbs.</td> </tr> <tr> <td>557.00</td> </tr> </table>	ID 3 DRAWERS	19 MLN-MNBFPPLGS 15½" x 18¼" x 26¾"	74 lbs.	557.00
ID																																			
13 MLN-MGDCLGS 36" x 20" x 39¼"																																			
111 lbs.																																			
1,083.00																																			
ID																																			
14 MLN-MSCLGS 36" x 20" x 29½"																																			
91 lbs.																																			
837.00																																			
ID																																			
15 MLN-MNPOLGS 15" x 15" x 20"																																			
22 lbs.																																			
132.00																																			
ID 2 SHELVES																																			
16 MLN-MVBQ2LGS 20" x 20" x 29½"																																			
37 lbs.																																			
261.00																																			
ID																																			
17 MLN-MNCR48LGS 48" dia. x 29½"																																			
90 lbs.																																			
720.00																																			
ID 5 SHELVES																																			
18 MLN-MVB5LGS 36" x 13" x 68"																																			
146 lbs.																																			
707.00																																			
ID 3 DRAWERS																																			
19 MLN-MNBFPPLGS 15½" x 18¼" x 26¾"																																			
74 lbs.																																			
557.00																																			

20-MF-L-FCL

# Office Suites Laminate



## Series A Collection

Lightly scaled and open, providing added legroom.

- Desk surfaces and legs feature wire management grommets to conceal your cables.
- Molded plastic feet have encapsulated steel armature and adjustable levelers for a stable design.
- Storage options improve work-in-process organization and include locking file drawers for added security.
- Hutches feature finished back panels for placement anywhere and convenient fabric tack boards.
- Factory assembled pedestals simplify installation.
- Manufacturer's ten-year warranty.
- Contains 5% post-consumer recycled content, 50% total recycled content.
- Level 1 Certified; Meets or exceeds ANSI/BIFMA Standards.



Hansen Cherry/Galaxy (944)

Natural Cherry/Slate Gray (574)



2mm thick impact-resistant edges.



Wire management grommets in worksurfaces and side panels.



Requires additional lead time and cannot be returned.

## Selection Guide For Series A Collection

	Workstation Desk				Corner Desk	Corner Connector	Peninsula
	<p>1" thick thermally fused laminate worksurface is glare-, scratch- and water-resistant. Durable edge banding helps reduce damage.</p>				<p>Use alone or between two Workstation Desks to form an "L" workstation.</p>	<p>Connects two Workstation Desks to form an "L". 1" thick melamine worksurface is glare-, scratch- and water-resistant with high-impact, durable edge banding.</p>	<p>1" thick thermally fused laminate worksurface with high-impact, dent-resistant, edge banding.</p>
	<b>ID 72" WIDE</b>	<b>ID 60" WIDE</b>	<b>ID 48" WIDE</b>	<b>ID 36" WIDE</b>	<b>ID LEFT</b>	<b>ID</b>	<b>ID</b>
H. Cherry/Galaxy	1 BSH-WC94472	3 BSH-WC90460A	5 BSH-WC90448A	7 BSH-WC90436A	9 BSH-WC90466A	11 BSH-WC90429A	13 BSH-WC90471A
N. Cherry/Slate	2 BSH-WC57472	4 BSH-WC57460	6 BSH-WC57448	8 BSH-WC57436	10 BSH-WC57466	12 BSH-WC57429	14 BSH-WC57471
SIZE (W x D x H)	71 1/2" x 26 1/2" x 29 1/2"	59 1/2" x 26 1/2" x 29 1/2"	47 1/2" x 26 1/2" x 29 1/2"	35 1/2" x 26 1/2" x 29 1/2"	47 1/4" x 47 1/4" x 29 1/2"	26 1/2" x 26 1/2"	71 1/4" x 26 1/2" x 29 1/2"
SHPG. WT.	102 lbs.	88 lbs.	71 lbs.	62 lbs.	118 lbs.	21 lbs.	93 lbs.
PRICE	548.00	494.00	421.00	388.00	527.00	188.00	455.00
	<p>For Workstation Desks. Open storage area has dividers for notebooks and files. Full-width, fabric-covered tackboard. Accommodates BBF Light Pack (sold separately).</p>				<p>With dividers and full-width fabric-covered tackboard. Accommodates two Light Packs BBF Light Pack (sold separately).</p>		
	<b>72" WIDE (OPEN CENTER SECTION)</b>	<b>ID 60" WIDE</b>	<b>48" WIDE (LARGE OPEN CENTER SECTION)</b>	<b>36" WIDE (NARROW OPEN CENTER SECTION)</b>	<b>ID CARTON 1</b>	<b>ID CARTON 2</b>	
H. Cherry/Galaxy	15 BSH-WC94473	17 BSH-WC94461	19 BSH-WC94449	21 BSH-WC94437	23 BSH-WC94467PA1	25 BSH-WC94467PA2	
N. Cherry/Slate	16 BSH-WC57473	18 BSH-WC57461	20 BSH-WC57449	22 BSH-WC57437	24 BSH-WC57467PA1	26 BSH-WC57467PA2	
SIZE (W x D x H)	71 1/2" x 13 1/2" x 36 1/2"	59 1/2" x 13 1/2" x 36 1/2"	47 1/2" x 13 1/2" x 36 1/2"	35 1/2" x 13 1/2" x 36 1/2"	47 1/4" x 47 1/4" x 36 1/2"	47 1/4" x 47 1/4" x 36 1/2"	
SHPG. WT.	136 lbs.	121 lbs.	104 lbs.	83 lbs.	94 lbs.	94 lbs.	
PRICE	960.00	934.00	669.00	527.00	499.00	499.00	
	<p>Locking drawers feature hanging file suspension for letter or legal size files.</p>	<p>Fully assembled. Freestanding or fit under 30" high desks. File drawers accommodate letter/legal size hanging files. Full-extension ball bearing slides allow full access to drawers. Four casters for easy mobility. Key lock.</p>		<p>Accommodates keyboard and mouse.</p>	<p>Holds keyboard and mouse. Designed to fit straight front worksurfaces, L-Box corner desks.</p>	<p>Routed groove holds pens and pencils. Metal slides provide easy opening and closing. Black.</p>	
	<b>ID 2 DRAWERS</b>	<b>ID 3 DRAWERS</b>		<b>ID 2 DRAWERS</b>	<b>ID BLACK</b>	<b>ID BLACK</b>	
H. Cherry/Galaxy	27 BSH-WC94454ASU	29 BSH-WC94453SU	31 BSH-WC94452SU	33 BSH-AC99801-03	34 BSH-AC99808-03	35 BSH-AC99850	
N. Cherry/Slate	28 BSH-WC57454ASU	30 BSH-WC57453SU	32 BSH-WC57452SU	24 1/2" x 22 1/4" x 3 1/2"	30 1/8" x 16 1/8"	26 1/8" x 15 1/8" x 2 3/4"	
SIZE (W x D x H)	35 3/4" x 23 3/8" x 29 7/8"	15 3/4" x 20 1/4" x 27 7/8"		15 3/4" x 20 1/4" x 27 7/8"	20 lbs.	11 lbs.	
SHPG. WT.	146 lbs.	63 lbs.		63 lbs.	10 lbs.	11 lbs.	
PRICE	953.00	533.00		521.00	155.00	196.00	



**Straight Desk**



**L-Desk**  
Quick, efficient setup for single or multiple workstations.



**U-Configuration**

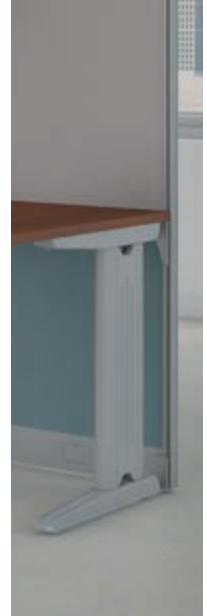

# Office in an Hour™ Workstations





A desk/cubicle kit to create an instant office for one or many.

- Choose an L-workstation with panels, a U-workstation with panels or a straight workstation with panels.
- Durable, thermally-fused laminate surfaces are scratch- and stain-resistant and feature desktop grommets for convenient wire management.
- Removable metal face plate on desk legs hide cords and cables.
- Sturdy, metal-framed panels covered in stylish two-tone fabric.
- Adjustable levelers compensate for uneven floor surfaces.
- Manufacturer's ten-year warranty.
- Contains 13% post-consumer recycled content, 13% total recycled content.
- Meets or exceeds ANSI/BIFMA Standards. ♻️ ♻️ ♻️ ♻️ ♻️



Hansen Cherry

## Selection Guide For Office In An Hour Workstations

	U-Workstation	L-Workstation	Straight Workstation	Pedestal File	Accessory/Hutch
					
	U-Station bridge not freestanding. Combine with L-Workstation to create a U-Workstation. Ships in three cartons—ORDER ALL THREE CARTONS.	Ships in two cartons—ORDER BOTH CARTONS.	Ships in two cartons—ORDER BOTH CARTONS.	Includes two box drawers and a file drawer for letter- and legal-sized folders.	Includes storage cabinet, adjustable paper tray and pencil cup
<b>ID</b>	1 BSH-WC36496-03	4 BSH-WC36494A1-03	6 BSH-WC36492A1-03	<b>ID 3 DRAWERS</b>	<b>ID</b>
	2 BSH-WC36494A1-03	5 BSH-WC36494A2-03	7 BSH-WC36492A2-03	8 BSH-WC36453-03	9 BSH-WC36497-03
	3 BSH-WC36494A2-03				
<b>SIZE (W × D × H)</b>	88¼" × 64½" × 63"	64½" × 64½" × 63"	64½" × 32¼" × 63"	15.984" × 20.079" × 25.374"	31.496" × 13.622" × 13.504"
<b>SHPG. WT.</b>	81 lbs. ♻️ ♻️ ♻️ ♻️ ♻️	131 lbs. ♻️ ♻️ ♻️ ♻️ ♻️	112 lbs. ♻️ ♻️ ♻️ ♻️ ♻️	80 lbs.	55 lbs.
<b>PRICE</b>	1,050.00	1,043.00	746.00	544.00	351.00

20-MF-L-FCL

Hansen Cherry/Silver





## Open Office Desk Series

Modular light scale desking for the contemporary open-plan office.

- Durable steel frame adjusts to fit standard 48" to 72" wide work surfaces.
- Scratch, dent and spill resistant thermally fused laminate work surfaces.
- Low-profile, practical storage solutions fit in compact spaces.
- Mix-and-match components and color options combine to offer flexible design choices.
- Manufacturer's limited five-year warranty.
- Meets or Exceeds ANSI/BIFMA Standards.

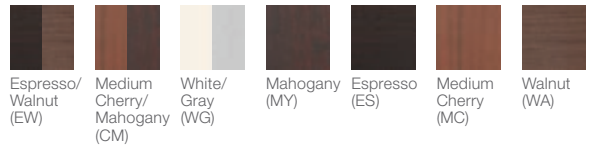

### Selection Guide For Alera® Open Office Desk Series

<p>Reversible wood grain laminate tabletops. 1" thick.</p>	<p><b>Reversible Table Top</b></p>					<p><b>Adjustable O-Leg Desk Base</b></p> <p>Includes two full length O-leg supports and one short O-leg support. Use short O-leg support to create worksurface on top of low credenza units. Add low profile storage solutions to create layered "L" or "U" shaped configurations.</p>		<p><b>O-Leg Return Base</b></p> <p>Durable steel frame. Includes one O-leg and one bracket to attach as return to any desk.</p>
	<p>Espresso/Walnut Medium Cherry/Mahogany White/Gray</p>	<p>1 ALE-TT7230EW 2 ALE-TT7230CM 3 ALE-TT7230WG</p>	<p>4 ALE-TT7224EW 5 ALE-TT7224CM 6 ALE-TT7224WG</p>	<p>7 ALE-TT6030EW 8 ALE-TT6030CM 9 ALE-TT6030WG</p>	<p>10 ALE-TT6024EW 11 ALE-TT6024CM 12 ALE-TT6024WG</p>	<p>13 ALE-TT4824EW 14 ALE-TT4824CM 15 ALE-TT4824WG</p>	<p>ID 30" DEPTH 16 ALE-LSTB30GR</p>	<p>ID 24" DEPTH 17 ALE-LSTB24GR</p>
<p>SIZE (W x D)</p>	71½" x 29½"	71½" x 23½"	59½" x 29½"	59½" x 23½"	47½" x 23½"	47½" to 70½" x 29½" x 28½"	47¼" to 70½" x 23½" x 28½"	36" to 70½" x 23½" x 28½"
<p>SHPG. WT. PRICE</p>	58 lbs. 269.00	48 lbs. 199.00	46 lbs. 239.00	40 lbs. 169.00	33 lbs. 149.00	60 lbs. 500.00	55 lbs. 470.00	21 lbs. 185.00
<p>Espresso Mahogany Medium Cherry Walnut</p>	<p><b>Low File Cabinet Credenza</b></p> <p>Three storage spaces including lateral file drawer, pencil drawer and open storage. Leveling glides compensate for uneven floors. Two fold-away safety keys. Accommodates letter or legal filing. Add seat cushion to expand seating space.</p>		<p><b>Low Storage Cabinet Credenza</b></p> <p>Sliding doors are removable for open storage. Add a coordinated cushion top to expand your seating space.</p>		<p><b>Lateral File</b></p> <p>Freestanding. Locking drawers with fold-away safety keys (included).</p>	<p><b>Mobile Box/File Pedestal</b></p> <p>Two fold-away safety keys included. Accepts Alera® Pedestal Cushions.</p>	<p><b>Mobile Pedestal with Full-Length Recessed Pulls</b></p> <p>Metal construction. Compatible with Alera® seat cushion. Lockable.</p>	
	<p>SIZE (W x D x H)</p>	29½" x 19½" x 22½"		29½" x 19½" x 22½"		34" x 22¾" x 29½"	15¾" x 19½" x 22½"	14¾" x 19½" x 21½"
<p>SHPG. WT. PRICE</p>	95 lbs. 495.00		65 lbs. 440.00		142 lbs. 615.00	55 lbs. 375.00	66 lbs. 349.00	
<p>Smoke Tan Quartz</p>	<p><b>Seat Cushion</b></p> <p>Fits all Alera® laminate and metal pedestals.</p>		<p><b>Core Removable Lock and Key Set</b></p> <p>Two fold away safety keys and one lock core included.</p>		<p><b>Polycarbonate Privacy Panel</b></p> <p>Divides workspaces, but allows light to pass through. Secure clip-on attachment.</p>			
	<p>SIZE (W x D x H)</p>	14¾" x 19½" x 2½"		41 ALE-VA50-1111		42 ALE-PP4718		
<p>SHPG. WT. PRICE</p>	17 lbs. 87.00		6 lbs. 22.00		47" x ½" x 18" 8 lbs. 190.00			
					43 ALE-PP6518			
					65" x ½" x 18" 9 lbs. 249.00			

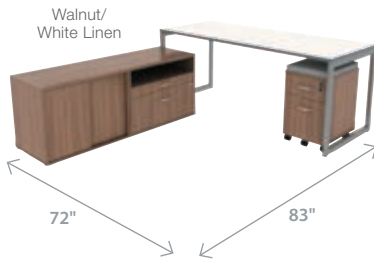

**L-Workstation 2,066.00**

Qty.	Item No.	Description
1	ALE-TT7224WG	72"W x 24"D Reversible Table Top
1	ALE-LS583020WA	Low File Credenza
1	ALE-LS593020WA	Open Low Storage Cabinet
1	ALE-VABFWA	Box/File Pedestal
1	ALE-LSTB24GR	24" Adjustable O-Leg Desk Base
1	ALE-PC1551	Seat Cushion

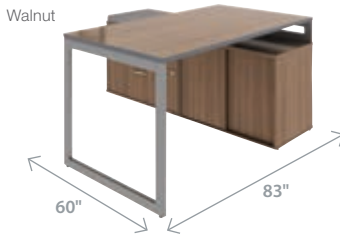

**U-Workstation 2,412.00**

Qty.	Item No.	Description
1	ALE-TT6024EW	Reversible Table Top
1	ALE-TT6030EW	30" Adjustable O-Leg Desk Base
1	ALE-LSTB24GR	24" Adjustable O-Leg Desk Base
1	ALE-LS583020WA	Open Low File Cabinet
1	ALE-LSTB30GR	30" Adjustable O-Leg Desk Base
1	ALE-LS593020WA	Open Low Storage Cabinet
1	ALE-PC3051	Seat Cushion

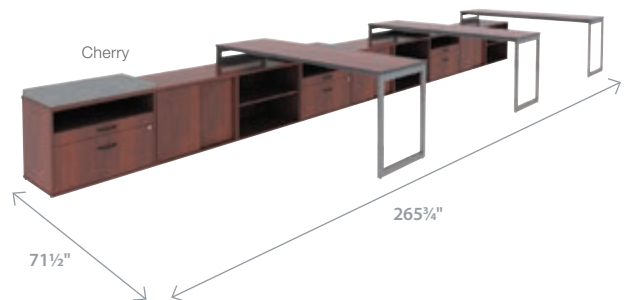

**Teaming Station with Storage 6,429.00**

Qty.	Item No.	Description
3	ALE-TT7224CM	72"W x 24"D Reversible Table Top
6	ALE-LS593020MC	Open Low Storage Cabinet
3	ALE-LS583020MC	Open Low File Cabinet
3	ALE-LSTB24GR	24" Adjustable O-Leg Desk Base
3	ALE-PC3051	Seat Cushion

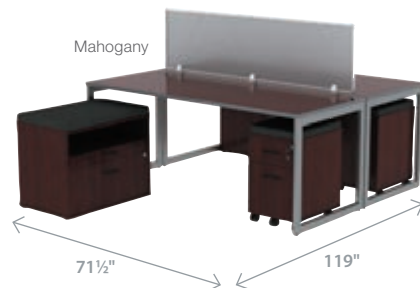

**Two Person Workstation with Privacy Panel 3,899.00**

Qty.	Item No.	Description
2	ALE-TT7230CM	72"W x 30"D Reversible Table Top
2	ALE-LS583020MY	Low File Credenza
2	ALE-VABFMY	Mobile Box/File Pedestal
1	ALE-PP6518	Privacy Panel
2	ALE-LSTB30GR	30" Adjustable O-Leg Desk Base
2	ALE-PC3011	Seat Cushion for Low Credenza
2	ALE-PC1511	Seat Cushion for File Pedestal

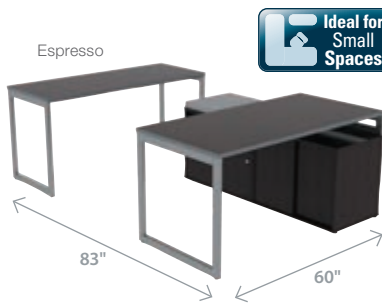

**U-Workstation 2,412.00**

Qty.	Item No.	Description
1	ALE-TT6024EW	60"W x 24"D Reversible Table Top
1	ALE-LS583020ES	Low File Cabinet Credenza
1	ALE-LS593020ES	Low Storage Cabinet Credenza
1	ALE-TT6030EW	60"W x 30"D Reversible Table Top
1	ALE-LSTB24GR	24" Deep Adjustable O-Leg Desk Base
1	ALE-LSTB30GR	30" Deep Adjustable O-Leg Desk Base
1	ALE-PC3051	Seat Cushion for Low Credenza



**L-workstation with Storage 2,265.00**

Qty.	Item No.	Description
1	ALE-TT7230CM	72"W x 30"D Reversible Table Top
1	ALE-LS583020MY	Low File Cabinet Credenza
1	ALE-LS593020MY	Low Storage Cabinet Credenza
1	ALE-VABFMY	Mobile Box/File Pedestal
1	ALE-LSTB30GR	30" Deep Adjustable O-Leg Desk Base
1	ALE-PC1551	Seat Cushion for File Pedestal
1	ALE-PC3051	Seat Cushion for Low Credenza

20-MF-L-FCL

## Office Suites Laminate

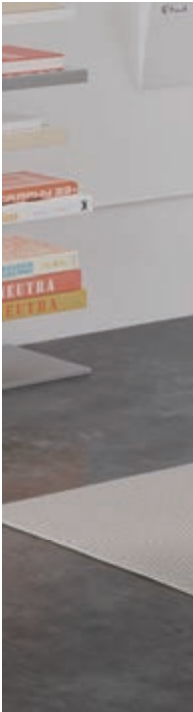

# Manage® Series

Your business. Your workspace.

**HON.**



- An affordable collection of essential workstation components, built for change.
- Pedestals and File Centers with drawer ship fully assembled.
- Durable, easy-care laminate is scratch-, spill- and stain-resistant.
- 1" thick desk top provides a sturdy, durable workspace.
- Steel construction on desk legs offers greater strength and support.
- Non-handed desk design simplifies ordering and supports both left-handed and right-handed users.
- Backed by the HON Limited Five-Year Warranty.



**Typicals can be reconfigured for left- or right-handed applications.**



### THE MANAGE ADVANTAGE:

Two factory-installed steel beams reinforce the workspace for strength and rigidity.

Suggested Seating  
Each 999.00  
BSX-VL531MM10  
ID 1  
Complement your office suite with the HON Prominent™ Mesh High-Back Task Chair.



# Manage® supports left- and right-handed users.

Non-handed desk design simplifies ordering and supports both left-handed and right-handed users with the same components!

The simplified set of elements enables quick and easy reconfiguration and customization, allowing Manage™ to adapt as needs change.

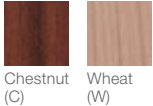

## Selection Guide For Manage™ Series

	<p><b>Worksurface</b></p> <p>Two factory-installed steel beams reinforce the worksurface for strength and rigidity. Grommets provide easy cord management and hide unsightly wires.</p> <table border="0"> <tr> <td><b>ID 72" WIDE</b></td> <td><b>ID 60" WIDE</b></td> </tr> <tr> <td>1 BSX-MG72WKC1A1</td> <td>3 BSX-MG60WKC1A1</td> </tr> <tr> <td>2 BSX-MG72WKWHA1</td> <td>4 BSX-MG60WKWHA1</td> </tr> </table> <table border="0"> <tr> <td><b>SIZE (W × D × H)</b></td> <td>72" × 23½" × 1"</td> <td>60" × 23½" × 1"</td> </tr> <tr> <td><b>SHPG. WT.</b></td> <td>57 lbs. 📦</td> <td>47 lbs. 📦</td> </tr> <tr> <td><b>PRICE</b></td> <td>300.00</td> <td>259.00</td> </tr> </table>		<b>ID 72" WIDE</b>	<b>ID 60" WIDE</b>	1 BSX-MG72WKC1A1	3 BSX-MG60WKC1A1	2 BSX-MG72WKWHA1	4 BSX-MG60WKWHA1	<b>SIZE (W × D × H)</b>	72" × 23½" × 1"	60" × 23½" × 1"	<b>SHPG. WT.</b>	57 lbs. 📦	47 lbs. 📦	<b>PRICE</b>	300.00	259.00	<p><b>Desk Leg</b></p> <p>Fully assembled and ready to attach to worksurface (sold separately). Leveling glides compensate for uneven floors.</p> <table border="0"> <tr> <td><b>ID</b></td> <td>5 BSX-MGDLEGA1</td> </tr> <tr> <td><b>SIZE (W × D × H)</b></td> <td>2¼" × 23½" × 28½"</td> </tr> <tr> <td><b>SHPG. WT.</b></td> <td>14 lbs.</td> </tr> <tr> <td><b>PRICE</b></td> <td>111.00</td> </tr> </table>	<b>ID</b>	5 BSX-MGDLEGA1	<b>SIZE (W × D × H)</b>	2¼" × 23½" × 28½"	<b>SHPG. WT.</b>	14 lbs.	<b>PRICE</b>	111.00	<p><b>Pedestal File</b></p> <p>Two pencil drawers (one locking and one non-locking) and one locking file drawer.</p> <table border="0"> <tr> <td><b>ID 3 DRAWERS</b></td> <td>6 BSX-MGPEDC1A1</td> </tr> <tr> <td></td> <td>7 BSX-MGPEDWHA1</td> </tr> <tr> <td><b>SIZE (W × D × H)</b></td> <td>15¾" × 21" × 22"</td> </tr> <tr> <td><b>SHPG. WT.</b></td> <td>69 lbs. 📦</td> </tr> <tr> <td><b>PRICE</b></td> <td>388.00</td> </tr> </table>	<b>ID 3 DRAWERS</b>	6 BSX-MGPEDC1A1		7 BSX-MGPEDWHA1	<b>SIZE (W × D × H)</b>	15¾" × 21" × 22"	<b>SHPG. WT.</b>	69 lbs. 📦	<b>PRICE</b>	388.00		
	<b>ID 72" WIDE</b>	<b>ID 60" WIDE</b>																																					
1 BSX-MG72WKC1A1	3 BSX-MG60WKC1A1																																						
2 BSX-MG72WKWHA1	4 BSX-MG60WKWHA1																																						
<b>SIZE (W × D × H)</b>	72" × 23½" × 1"	60" × 23½" × 1"																																					
<b>SHPG. WT.</b>	57 lbs. 📦	47 lbs. 📦																																					
<b>PRICE</b>	300.00	259.00																																					
<b>ID</b>	5 BSX-MGDLEGA1																																						
<b>SIZE (W × D × H)</b>	2¼" × 23½" × 28½"																																						
<b>SHPG. WT.</b>	14 lbs.																																						
<b>PRICE</b>	111.00																																						
<b>ID 3 DRAWERS</b>	6 BSX-MGPEDC1A1																																						
	7 BSX-MGPEDWHA1																																						
<b>SIZE (W × D × H)</b>	15¾" × 21" × 22"																																						
<b>SHPG. WT.</b>	69 lbs. 📦																																						
<b>PRICE</b>	388.00																																						
	<p><b>Table Desk</b></p> <p>This pre-configured desk is ready to order and ship without guesswork. All needed components are pre-specified using a single model number.</p> <table border="0"> <tr> <td><b>ID 60" WIDE</b></td> <td><b>ID 48" WIDE</b></td> </tr> <tr> <td>8 BSX-MNG60WKSCLC</td> <td>10 BSX-MNG48WKSCLC</td> </tr> <tr> <td>9 BSX-MNG60WKSLLW</td> <td>11 BSX-MNG48WKSLLW</td> </tr> </table> <table border="0"> <tr> <td><b>SIZE (W × D × H)</b></td> <td>60" × 23½" × 29½"</td> <td>48" × 23½" × 29½"</td> </tr> <tr> <td><b>SHPG. WT.</b></td> <td>78 lbs. 📦</td> <td>59 lbs. 📦</td> </tr> <tr> <td><b>PRICE</b></td> <td>452.00</td> <td>433.00</td> </tr> </table>	<b>ID 60" WIDE</b>	<b>ID 48" WIDE</b>	8 BSX-MNG60WKSCLC	10 BSX-MNG48WKSCLC	9 BSX-MNG60WKSLLW	11 BSX-MNG48WKSLLW	<b>SIZE (W × D × H)</b>	60" × 23½" × 29½"	48" × 23½" × 29½"	<b>SHPG. WT.</b>	78 lbs. 📦	59 lbs. 📦	<b>PRICE</b>	452.00	433.00	<p><b>Modesty Panel</b></p> <p>Fits beneath any flip base table or fixed base table to provide added privacy. Fabric mesh is securely attached to a durable steel rod frame. Swivels as flip base tables are tilted. Also compatible with basyx by HON Manage® desks. Mesh top.</p> <table border="0"> <tr> <td><b>ID FOR 72" DESK</b></td> <td><b>ID FOR 60" DESK</b></td> </tr> <tr> <td>12 BSX-BMPT72MOD</td> <td>13 BSX-BMPT60MOD</td> </tr> <tr> <td><b>SIZE (W × H × D)</b></td> <td>60½" × ¾" × 10"</td> <td>49" × ¾" × 10"</td> </tr> <tr> <td><b>SHPG. WT.</b></td> <td>4 lbs. 📦</td> <td>3 lbs. 📦</td> </tr> <tr> <td><b>PRICE</b></td> <td>142.00</td> <td>126.00</td> </tr> </table>	<b>ID FOR 72" DESK</b>	<b>ID FOR 60" DESK</b>	12 BSX-BMPT72MOD	13 BSX-BMPT60MOD	<b>SIZE (W × H × D)</b>	60½" × ¾" × 10"	49" × ¾" × 10"	<b>SHPG. WT.</b>	4 lbs. 📦	3 lbs. 📦	<b>PRICE</b>	142.00	126.00	<p><b>Power Hub</b></p> <p>Fits 3" grommet holes. Two grounded AC outlets. 6 ft. power cord. Backed by the HON Full Lifetime Warranty.</p> <table border="0"> <tr> <td><b>ID</b></td> <td>14 HON-GRMTACX</td> </tr> <tr> <td><b>SIZE (W × D)</b></td> <td>3" w × 3" d</td> </tr> <tr> <td><b>SHPG. WT.</b></td> <td>1 lb. 📦</td> </tr> <tr> <td><b>PRICE</b></td> <td>111.00</td> </tr> </table>	<b>ID</b>	14 HON-GRMTACX	<b>SIZE (W × D)</b>	3" w × 3" d	<b>SHPG. WT.</b>	1 lb. 📦	<b>PRICE</b>	111.00
<b>ID 60" WIDE</b>	<b>ID 48" WIDE</b>																																						
8 BSX-MNG60WKSCLC	10 BSX-MNG48WKSCLC																																						
9 BSX-MNG60WKSLLW	11 BSX-MNG48WKSLLW																																						
<b>SIZE (W × D × H)</b>	60" × 23½" × 29½"	48" × 23½" × 29½"																																					
<b>SHPG. WT.</b>	78 lbs. 📦	59 lbs. 📦																																					
<b>PRICE</b>	452.00	433.00																																					
<b>ID FOR 72" DESK</b>	<b>ID FOR 60" DESK</b>																																						
12 BSX-BMPT72MOD	13 BSX-BMPT60MOD																																						
<b>SIZE (W × H × D)</b>	60½" × ¾" × 10"	49" × ¾" × 10"																																					
<b>SHPG. WT.</b>	4 lbs. 📦	3 lbs. 📦																																					
<b>PRICE</b>	142.00	126.00																																					
<b>ID</b>	14 HON-GRMTACX																																						
<b>SIZE (W × D)</b>	3" w × 3" d																																						
<b>SHPG. WT.</b>	1 lb. 📦																																						
<b>PRICE</b>	111.00																																						

20-MF-L-FCL

# Office Suites Table Desks

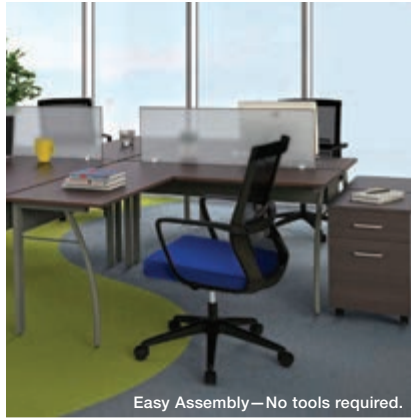

Easy Assembly—No tools required.

**LI** linea italia®  
by CRISA



## Trento Line

Stylish minimalist design for universal appeal.

- Simple to configure desks to fit most any office layout.
- Scratch- and stain-resistant woodgrain laminate with durable edge.
- Fully assembled.
- Strong powder coated steel frames.
- Adjustable leveling glides for stability.
- Manufacturer's limited five-year warranty.
- Meets or Exceeds ANSI/BIFMA Standards.



### Selection Guide For Trento Line

	<b>L-Shaped Desk</b>	<b>Rectangle Desk</b>	<b>Bookcase</b>	<b>Mobile Pedestal File</b>	<b>Polycarbonate Dividing Panel</b>
	Configure right- or left-handed to suit your requirements and space. Includes two metal modesty panels. Added privacy with optional Dividing Panel.	Configure multiple desks to perfectly fit your space. Includes metal modesty panels. Pedestals fit under desk. Added privacy with optional Dividing Panel.	Strong powder coated steel frame with laminate shelves.	Full-extension locking metal drawers operate on steel ball bearing slides and accommodate letter- and legal-size files. Four hooded dual-wheel casters for easy mobility. No assembly required.	No need to feel like you are on display for all to see. Created to allow light through but obscures objects for added privacy. Simple clip-on design attaches to desk with ease. Durable aluminum frame for stability. Quick and easy assembly—no tools required.
	ID	ID	ID 3 SHELVES	ID 2 DRAWERS	ID
Cherry	1 LIT-TR737CH	3 LIT-TR742CH	7 LIT-TR735CH	9 LIT-TR752CH	11 LIT-TR721
Mocha	2 LIT-TR737MOC	4 LIT-TR742MOC	8 LIT-TR735MOC	10 LIT-TR752MOC	
SIZE (W × D × H)	59½" × 59½" × 29½"	59½" × 23½" × 29½"    47¼" × 23½" × 29½"	31½" × 11½" × 43¼"	16½" × 19¾" × 23½"	
SHPG. WT.	87 lbs.	60 lbs.	55 lbs.	53 lbs.	15 lbs.
PRICE	515.00	409.00    315.00	339.00	329.00	499.00



**LI** linea italia®  
by CRISA

## Urban Series

Create the ideal space to work comfortably.

- Modern, elegant design is perfect for any home or office.
- Easy-to-clean laminate surface resists scratches, spills and stains.
- Easy to assemble without tools.



### Selection Guide For Urban Series

	<b>L-Shaped Desk</b>	<b>Desk Workstation</b>	<b>Low File Cabinet Credenza</b>	<b>Urban Mobile File Pedestal</b>
	Configures right or left to suit your needs. Steel legs hold up to heavy use and frequent relocation.	Steel legs hold up to heavy use and frequent relocation.	Sturdy shelves accommodate files, books, binders, reference materials and more.	Convenient storage made simple.
	ID	ID	ID	ID 2 DRAWERS—BOX/FILE
Ash Gray	12 LIT-UR602ASH	14 LIT-UR601ASH	18 LIT-UR604ASH	20 LIT-UR610ASH
Walnut	13 LIT-UR602NW	15 LIT-UR601NW	19 LIT-UR604NW	21 LIT-UR610NW
SIZE (W × D × H)	59" × 59" × 29½"	59" × 23¾" × 29½"	35¼" × 15¼" × 23¾"	16" × 15¼" × 23¾"
SHPG. WT.	91 lbs.	54 lbs.	82 lbs.	50 lbs.
PRICE	549.00	359.00	629.00	289.00



**new**



## Industrial Series Table Desk

### A INDUSTRIAL SERIES TABLE DESK

Table desk/writing desk is perfect for the home or small office. Durable laminate top with squared steel powder coated legs. Cross-stability bar to prevent rocking and to ensure a stable feel. Leveling glides included to adjust for uneven floors. Manufacturer's limited five-year warranty.

ID No.	Color	W x D x H	Shpg. Wt.	Unit	Price
1 ALE-LTD4824WA	Modern Walnut/ Matte Dark Gray	47¼" x 23¾" x 29½"	52 lbs.	Each	<del>325.00</del>



**new**



## Sit-to-Stand Table Desk

### B SIT-TO-STAND TABLE DESK

Writing desk with built-in height adjustable work surface. Ideal for the home or small office. Lift portion of the desk surface has infinite height adjustability that can be locked in several positions within a 14" range. Lift portion easily returns to seated height and remains flush with top surface. Stylish tapered legs with leveling glides to adjust for uneven floors. Manufacturer's limited five-year warranty.

ID No.	Color	W x D x H	Shpg. Wt.	Unit	Price
2 ALE-LD4824WA	Modern Walnut	47¼" x 23¾" x 43¾"	75 lbs.	Each	<del>689.00</del>

**HON.**

## Manage<sup>®</sup> Series

Your business. Your workspace.

- An affordable collection of essential workstation components, built for change.
- Pedestals with drawer ship fully assembled.
- Durable, easy-care laminate is scratch-, spill- and stain-resistant.
- 1" thick desk top provides a sturdy, durable work surface.
- Steel construction on desk legs offers greater strength and support.
- Non-handed desk design simplifies ordering and supports both left-handed and right-handed users.
- Backed by the HON Limited Five-Year Warranty.



## Selection Guide For Manage<sup>®</sup> Series

### Table Desk

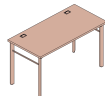

This pre-configured desk is ready to order and ship without guesswork. All needed components are pre-specified using a single model.

	ID 60" WIDE	ID 48" WIDE
Chestnut	3 BSX-MNG60WKSCLC	5 BSX-MNG48WKSCLC
Wheat	4 BSX-MNG60WKSCLW	6 BSX-MNG48WKSCLW
SIZE (W x D x H)	60" x 23½" x 29½"	48" x 23½" x 29½"
SHPG. WT.	78 lbs.	59 lbs.
PRICE	452.00	433.00

### Mobile Pedestal File



Two pencil drawers (one locking and one non-locking) and one locking file drawer.

ID	3 DRAWERS
7	BSX-MGPEDC1A1
8	BSX-MGPEDWHA1
	15¾" x 21" x 22"
	69 lbs.
	388.00

### The Manage Advantage:

Two factory-installed steel beams reinforce the work surface for strength and rigidity.







- Ideal for everything from private office and open plan spaces to benching applications, all while promoting productivity and collaboration.
- Thermally-fused laminate worksurfaces with matching casegoods.
- Manufacturer's limited lifetime warranty.
- Intertek Certified.

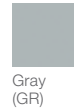

## Selection Guide For e5 Open Desking Series

	Standing Height Desk	Storage Pedestal	Bookcases
	Top portion can be mounted on right or left side during assembly. Unique design swings open to provide additional workspace as needed.	Versatile design allows it to be used on its own or nested underneath work surfaces.	Four shelves for storage of books, files, office supplies or other resources.
<b>ID</b>	1 SAF-1904GR	<b>ID 2 DRAWERS</b> 2 SAF-1906GR	<b>ID 4 SHELVES</b> 3 SAF-1903GR
<b>SIZE (W x D x H)</b>	53 1/4" x 21 3/4" x 42 1/4"	17 3/4" x 17 3/4" x 30"	31 3/4" x 12" x 59"
<b>SHPG. WT.</b>	90 lbs.	40 lbs.	61 lbs.
<b>PRICE</b>	385.00	286.00	364.00

# HON®



2-Leg 3-Stage  
Height-Adjustable Base

## Coordinate™

### Expanding Your Workspace Possibilities.

It's time to adjust to the ups and downs of office life. Embrace the new workday and a healthier work style with the Coordinate height-adjustable 2- or 3-leg base and desktop riser. Call your sales representative to learn more.



Portable Desktop Riser



3-Leg 3-Stage  
Height-Adjustable Bases







**38000 Series™** Settings with ¾ Pedestals

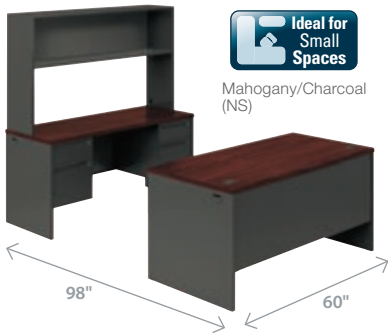

**Desk & Credenza Workstation with Stack-on Storage, 60"** **3,980.00**

Qty.	Item No.	Description
1	HON-38155NS	<b>60" Double Pedestal Desk</b>
1	HON-38852NS	<b>60" Credenza with Kneespace</b>
1	HON-38656ONS	<b>60" Stack-on Open Shelf</b>



Shown in Mahogany/Charcoal with HON Pillow-Soft Executive Chair.

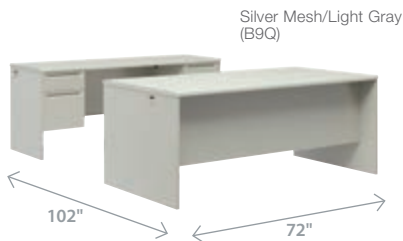

**Desk & Credenza Workstation** **3,536.00**

Qty.	Item No.	Description
1	HON-38180B9Q	<b>72" Double Pedestal Desk</b>
1	HON-38854B9Q	<b>72" Credenza with Kneespace</b>



**U-Workstation with Stack-on Storage, 72"** **4,521.00**

Qty.	Item No.	Description
1	HON-38293RNS	<b>72" Right Pedestal Desk</b>
1	HON-38210NS	<b>Bridge</b>
1	HON-38855LNS	<b>72" Left Pedestal Credenza</b>
1	HON-386572NS	<b>72" Stack-on Open Shelf</b>

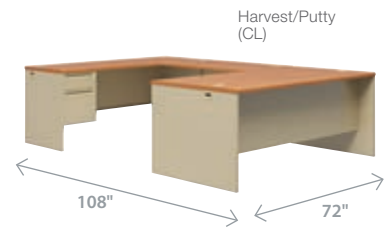

**U-Workstation** **3,655.00**

Qty.	Item No.	Description
1	HON-38293RCL	<b>72" Right Pedestal Desk</b>
1	HON-38210CL	<b>Bridge</b>
1	HON-38855LCL	<b>72" Left Pedestal Credenza</b>

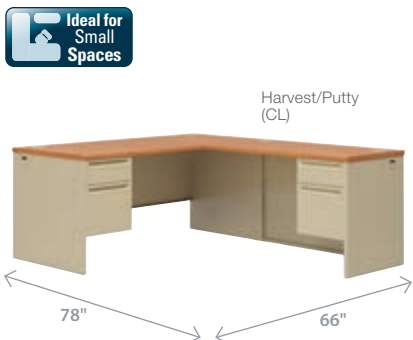

**L-Workstation** **2,576.00**

Qty.	Item No.	Description
1	HON-38292LCL	<b>66" Left Pedestal Desk</b>
1	HON-38215RCL	<b>Right Pedestal Return</b>



**Desk** **1,376.00**

Qty.	Item No.	Description
1	HON-38251B9Q	<b>48" Right Pedestal Desk</b>



**Desk with Stack-on Storage** **2,090.00**

Qty.	Item No.	Description
1	HON-38251CL	<b>48" Right Pedestal Desk</b>
1	HON-386548NL	<b>48" Stack-on Open Shelf</b>

20-MF-L-FCL



## Selection Guide for 38000 Series™ with ¾ Pedestals

	Double Pedestal Desk		Single Pedestal Desk				
	Locking box and file drawer in each pedestal. 6" conference overhang on 72" Desks.		Desk with locking box and file drawer. Use freestanding or combine 72" or 66" Desk to a Return to create an L-Workstation or 72" Desk with Bridge and Single Pedestal Credenza for a U-Workstation.				
	ID 72"	ID 60"	ID 72" RIGHT	ID 72" LEFT	ID 66" RIGHT	ID 66" LEFT	ID 48" RIGHT
Harvest/Putty	1 HON-38180CL	4 HON-38155CL	7 HON-38293RCL	10 HON-38294LCL	13 HON-38291RCL	16 HON-38292LCL	19 HON-38251CL
Mahogany/Charcoal	2 HON-38180NS	5 HON-38155NS	8 HON-38293RNS	11 HON-38294LNS	14 HON-38291RNS	17 HON-38292LNS	20 HON-38251NS
Silver Mesh/Light Gray	3 HON-38180B9Q	6 HON-38155B9Q	9 HON-38293RB9Q	12 HON-38294LB9Q	15 HON-38291RB9Q	18 HON-38292LB9Q	21 HON-38251B9Q
SIZE (W x D x H)	72" x 36" x 29½"	60" x 30" x 29½"	72" x 36" x 29½"	72" x 36" x 29½"	66" x 30" x 29½"	66" x 30" x 29½"	48" x 30" x 29½"
SHPG. WT.	256 lbs.	217 lbs.	214 lbs.	214 lbs.	181 lbs.	181 lbs.	155 lbs.
PRICE	1,893.00	1,619.00	1,688.00	1,688.00	1,555.00	1,555.00	1,376.00
	<b>Return</b>		<b>Bridge</b>	<b>Stack-on Open Shelf</b>			
	Attach Right Return to Left Pedestal Desk or Left Return to Right Pedestal Desk. Core removable lock.		Connects Single Pedestal Desk and Credenza to form a U-Workstation.	Mount on Desks, Credenzas or Returns. Overhead design saves floor space. Stores important materials within easy reach.			
	ID RIGHT	ID LEFT	ID 48" WIDE	ID 72" WIDE	ID 60" WIDE	ID 48" WIDE	
Harvest/Putty	22 HON-38215RCL	25 HON-38216LCL	28 HON-38210CL	31 HON-386572NS	34 HON-386560NS	37 HON-386548NS	
Mahogany/Charcoal	23 HON-38215RNS	26 HON-38216LNS	29 HON-38210NS	32 HON-386572NQ	35 HON-386560NQ	38 HON-386548NQ	
Silver Mesh/Light Gray	24 HON-38215RB9Q	27 HON-38216LB9Q	30 HON-38210B9Q	33 HON-386572NL	36 HON-386560NL	39 HON-386548NL	
SIZE (W x D x H)	48" x 24" x 29½"	48" x 24" x 29½"	48" x 24" x 29½"	72" x 13½" x 34¾"	60" x 13½" x 34¾"	48" x 13½" x 34¾"	
SHPG. WT.	124 lbs.	124 lbs.	54 lbs.	72 lbs.	64 lbs.	53 lbs.	
PRICE	1,021.00	1,021.00	567.00	890.00	782.00	714.00	
	<b>Single Pedestal Credenza</b>		<b>Credenza with Kneespace</b>		<b>Center Drawer</b>		
	Use alone or attach to Bridge and 72" Single Pedestal Desk to create a U-Workstation. Locking box and file drawers.		Locking box and file drawer in each pedestal. Core removable locks.		Includes pencil tray with three compartments. Core removable lock. For Single Pedestal Desks and Credenzas.		
	ID RIGHT	ID LEFT	ID 72"	ID 60"	ID FOR DOUBLE PEDESTAL DESK	ID FOR SINGLE PEDESTAL DESK	
Harvest/Putty	40 HON-38856RCL	43 HON-38855LCL	46 HON-38854CL	49 HON-38852CL	52 HON-D8S	55 HON-D2S	
Mahogany/Charcoal	41 HON-38856RNS	44 HON-38855LNS	47 HON-38854NS	50 HON-38852NS	53 HON-D8Q	56 HON-D2Q	
Silver Mesh/Light Gray	42 HON-38856RB9Q	45 HON-38855LB9Q	48 HON-38854B9Q	51 HON-38852B9Q	54 HON-D8L	57 HON-D2L	
SIZE (W x D x H)	72" x 24" x 29½"	72" x 24" x 29½"	72" x 24" x 29½"	60" x 24" x 29½"	24¾" x 14¾" x 3"	19" x 14¾" x 3"	
SHPG. WT.	159 lbs.	159 lbs.	172 lbs.	154 lbs.	12 lbs.	9 lbs.	
PRICE	1,400.00	1,400.00	1,643.00	1,579.00	252.00	252.00	
	<b>Corner Connector Sleeve</b>		<b>Task Light for Stack-on Storage</b>		<b>Oversized Keyboard Platform/Mouse Tray</b>		
	Black metal. Connects intersecting workspaces to create corner desk work areas.		Mounts under Stack-on Storage, sold separately. Fluorescent fixture with one bulb (incl.). 3 prong. UL Approved.		Supports both a keyboard and a mouse pad. Tray ergonomically positions a standard keyboard 3 inches below your work surface. Steel glides. Easy to install. Retracts when not in use.		
	ID		ID FOR 48" WIDE UNIT—WITH ELECTRONIC BALLAST.	ID FOR 60" OR 72" WIDE UNIT	ID		
Black	58 HON-51206P		59 HON-H870942	60 HON-H870960	61 HON-4028P		
SIZE (W x D x H)	22½" x 18"		34¾" x 3½"	46½" x 3½"	30" x 10"		
SHPG. WT.	10 lbs.		10 lbs.	12 lbs.	11 lbs.		
PRICE	155.00		250.00	270.00	153.00		

HON.



# Metro Classic Series

Retro Style. Modern Features.

- Scratch- and stain-resistant laminate tops.
- Color-matched legs, panels drawers and handles.
- Full-suspension file drawers.
- Universal-lock center drawer.
- Backed by the HON Full Lifetime Warranty.
- Contains 30% pre-consumer recycled content, 17% post recycled content.
- Level 2 Certified; Meets or Exceeds ANSI/BIFMA Standards and ISTA Performance Standards; SCS Indoor Advantage Gold Certified.

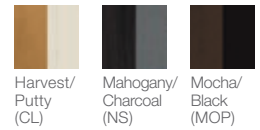

## Selection Guide For Metro Classic Series

Harvest/Putty Mahogany/Charcoal Mocha/Black SIZE (W x D x H) SHPG. WT. PRICE	<b>L-Workstation with Right Pedestal Desk</b>  One box and one file drawer. Center drawer locks all drawers in desk. Desk and Return sold and shipped separately—ORDER BOTH.		<b>L Workstation with Left Pedestal Desk</b>  One box and one file drawer. Center drawer locks all drawers in desk. Desk and Return sold and shipped separately—ORDER BOTH.	
	<b>ID RIGHT DESK</b> 1 HON-P3265RCL 2 HON-P3265RNS 3 HON-P3265RMOP 66" x 30" x 29½" 167 lbs. 1,219.00	<b>ID LEFT RETURN</b> 4 HON-P3236LCL 5 HON-P3236LNS 6 HON-P3236LMOP 42" x 24" x 29½" 95 lbs. 854.00	<b>ID LEFT DESK</b> 7 HON-P3266LCL 8 HON-P3266LNS 9 HON-P3266LMOP 66" x 30" x 29½" 167 lbs. 1,219.00	<b>ID RIGHT RETURN</b> 10 HON-P3235RCL 11 HON-P3235RNS 12 HON-P3235RMOP 42" x 24" x 29½" 95 lbs. 854.00
Harvest/Putty Mahogany/Charcoal Mocha/Black SIZE (W x D x H) SHPG. WT. PRICE	<b>Single Pedestal Desk</b>  Right pedestal with one box and one file drawer. Center drawer locks all drawers. ID 48" 13 HON-P3251RCL 14 HON-P3251RNS 15 HON-P3251RMOP 48" x 30" x 29½" 142 lbs. 1,088.00	<b>Double Pedestal Desk</b>  One box and one file drawer in each pedestal. Center drawer locks all drawers. ID 60" 16 HON-P3262CL 17 HON-P3262NS 18 HON-P3262MOP 60" x 30" x 29½" 186 lbs. 1,321.00	<b>Credenza with Kneespace</b>  One box and one file drawer in each pedestal, non-locking. ID 19 HON-P3231CL 20 HON-P3231NS 21 HON-P3231MOP 60" x 24" x 29½" 165 lbs. 1,321.00	<b>Corner Sleeve</b>  Black Metal. Connects intersecting workspaces to create corner desk work areas. ID 22 HON-51206P 22½" x 18" 10 lbs. 155.00
	Black Charcoal Putty SIZE (W x D x H) SHPG. WT. PRICE	<b>Stack-on Open Shelf</b>  Mount on Desks, Credenzas or Returns. Overhead design saves floor space. Stores important materials within easy reach.		<b>Bookcases</b>  Shelves adjust in ½" increments. Shelf count includes bottom of bookcase. Bookcases ship assembled.
<b>ID 60" WIDE</b> 23 HON-386560NS 24 HON-386560NL 60" x 13½" x 34¾" 64 lbs. 782.00		<b>ID 48" WIDE</b> 25 HON-386548NS 26 HON-386548NL 48" x 13½" x 34¾" 53 lbs. 714.00	<b>ID THREE SHELVES—TWO ADJUSTABLE</b> 27 HON-S42ABCP 28 HON-S42ABCS 29 HON-S42ABCL 34½" x 12¾" x 41" 57 lbs. 288.00	<b>ID TWO SHELVES—ONE ADJUSTABLE</b> 30 HON-S30ABCP 31 HON-S30ABCS 32 HON-S30ABCL 34½" x 12¾" x 29" 44 lbs. 240.00

20-MF-L-FCL



# Office Suites Steel



## 34000 Series Metal Desks

High-quality construction for heavy usage areas.

Shown with HON Convergence seating and HON Brigade® Lateral Files.



- Woodgrain laminate tops with chrome legs.
- High-sided file drawers accommodate hanging files.
- Double O-frame pedestal construction is exceptionally sturdy and durable.
- Backed by the HON Full Lifetime Warranty.
- Contains 30% pre-consumer recycled content, 17% post recycled content.
- Level 2 Certified; Meets or Exceeds ANSI/BIFMA Standards; SCS Indoor Advantage Gold Certified.



34000 Series  
& Utility Table

Brigade®  
700 Series



Harvest/  
Putty  
(CL)



Mocha/  
Black  
(MOP)



Black  
(P)



Putty  
(L)

## Selection Guide For 34000 Series

	Double Pedestal Desk	Single Pedestal Desk	Brigade® 700 Series Lateral Files	Utility Table
	One box and file drawer in each pedestal. Locking center drawer. With supply tray.	Right pedestal desk with box and file drawer. Locking center drawer. With supply tray.	Durable laminate top with painted apron and chrome legs.	High-pressure laminate top. Chrome legs.
ID		<b>45 1/4" RIGHT PEDESTAL</b>	<b>36" WIDE FILES</b>	
Harvest/Putty	1 HON-34962CL	3 HON-34002RCL	5 HON-782LP	7 HON-UTM2060CLCHR
Mocha/Black	2 HON-34962MOP	4 HON-34002RMOP	6 HON-782LL	8 HON-UTM2060MOPCH
Black				
Putty				
SIZE (W x D x H)	60" x 30" x 29 1/2"	45 1/4" x 24" x 29 1/2"	36" x 18" x 28 3/8"	60" x 20" x 29"
SHPG. WT.	162 lbs.	83 lbs.	132 lbs.	68 lbs.
PRICE	1,250.00	814.00	866.00	448.00

20-MF-L-FCL



## Steel Desks

Durable woodgrain laminate top is scratch-resistant.



- Powder coated steel frame.
- Features aluminum drawer handles and chrome-plated 1" sq. tubular steel legs with adjustable levelers.
- Central locking system for all drawers.
- Minimal assembly, just attach legs.
- Manufacturer's limited five-year warranty.
- Contains 17% post-consumer recycled content, 48% total recycled content.
- Meets or Exceeds ANSI/BIFMA Standards.



## Selection Guide For Steel Desks

	Double Pedestal Steel Desk	Single Pedestal Steel Desk	Double Pedestal Steel Credenza
	Full extension locking file drawers accommodate hanging file folders. Box drawers are equipped with dividers. Center drawer with supply tray.	Full extension locking file drawer accommodates hanging file folders. Box drawer is equipped with dividers. Center drawer with supply tray.	Full extension file drawer accommodates hanging file folders. Box drawer is equipped with dividers. Not locking.
<b>ID</b>	72"	60"	24" DEEP
<b>Cherry/Putty</b>	1 ALE-SD7236BM	2 ALE-SD6030PC	4 ALE-SD4524PC
<b>Mocha/Black</b>	3 ALE-SD6030BM	5 ALE-SD4524BM	6 ALE-SD6024BM
<b>SIZE (W x D x H)</b>	72" x 36" x 29½"	60" x 30" x 29½"	60" x 24" x 29½"
<b>SHPG. WT.</b>	203 lbs.	198 lbs.	160 lbs.
<b>PRICE</b>	1,487.00	1,253.00	1,235.00

20-MF-L-FCL

# Sit To Stand Tables

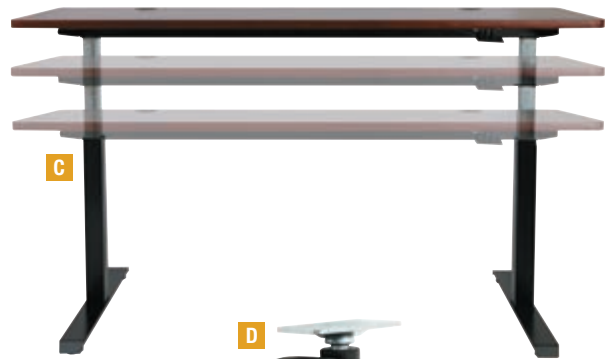

## Alera® AdaptivErgo® Height-Adjustable Table Base

Flexible, productive, ergonomic. These height-adjustable tables allow the user to move from sitting to standing with one touch.

- A great solution to retro-fit existing workspaces and add ergonomics to the office infrastructure.
- Solutions for every size, budget and requirement with electric or pneumatic controls.
- Bases accept most common sized workspaces.
- Strong powder coated steel frame with cross bars provides stability and prevents racking.
- Adjustable leveling glides to compensate for uneven floors.
- Manufacturer's limited five-year warranty.
- Meets or Exceeds ANSI/BIFMA Standards; UL Listed.

Top and Base sold and shipped separately—ORDER BOTH.

### A THREE-STAGE ELECTRIC HEIGHT-ADJUSTABLE TABLE BASE WITH MEMORY CONTROLS

Four-memory presets and up and down controls. Quick setup with fold-out legs requires minimal assembly. Durable base with 275-lb. lift capacity moves within a 25¾" range from 25" to 50¾" (not including worksurface). Attaches to most common workspaces ranging from 47" to 75" width; and 24" to 36" depth. Integrated cable management channels; includes 6.5 ft power cord. Dual motors with movement up to 1.5 inches per second depending on load. Accepts optional casters for mobility.

ID No.	Height	Color	Shpg. Wt.	Unit	Price
1 ALE-HT3SAB	25" - 50¾"	Black	71 lbs.	Each	<del>1,255.00</del>
2 ALE-HT3SAG	25" - 50¾"	Gray	71 lbs.	Each	<del>1,255.00</del>

### B TWO-STAGE ELECTRIC HEIGHT-ADJUSTABLE TABLE BASE

Standard up and down controls. Quick setup with fold-out legs requires minimal assembly. Durable base with 250-lb. lift capacity moves within a 20" range from 27¼" to 47¼" (not including worksurface). Attaches to most common workspaces ranging from 47" to 75" width and 24" to 36" depth. Integrated cable management channels; includes 6.5 ft power cord. Dual motors with movement up to 1.2 inches per second depending on load. Accepts optional casters for mobility.

ID No.	Height	Color	Shpg. Wt.	Unit	Price
3 ALE-HT2SSB	27¼" - 47¼"	Black	64 lbs.	Each	<del>1,129.00</del>
4 ALE-HT2SSG	27¼" - 47¼"	Gray	64 lbs.	Each	<del>1,129.00</del>

### C PNEUMATIC HEIGHT-ADJUSTABLE TABLE BASE

Pneumatic control lift-assist height-adjustable table base. No electricity needed. Durable base recommended for up to 100-lb. lift capacity, including weight of worksurface. Movement within a 13" range from 26¾" to 39¾". Accommodates most common workspaces ranging from 59" to 72" width and 24" to 30" depth.

ID No.	Height	Color	Shpg. Wt.	Unit	Price
5 ALE-HTPN1B	26¾" - 39¾"	Black	60 lbs.	Each	<del>749.00</del>
6 ALE-HTPN1G	26¾" - 39¾"	Gray	60 lbs.	Each	<del>749.00</del>

### D CASTERS FOR HEIGHT-ADJUSTABLE TABLE BASES

Move and reposition your Alera® Height-Adjustable Table Bases with these convenient casters. Easy to attach.

ID No.	Stem	Wheel Tread	Qty.	Unit	Price
7 ALE-HT3004	Grip Ring	Hard	4	Set	<del>57.00</del>



## Quick Comparison Chart

For Alera Height-Adjustable Table Bases  
(worksurface not included)

Item Number	ALE-HT3SAB/ALE-HT3SAG	ALE-HT2SSB/ALE-HT2SSG	ALE-HTPN1B/ALE-HTPN1G
Style	Electric;Dual Motor	Electric;Dual Motor	Pneumatic (non-electric)
Memory Setting/Presets	4 with display	No	No
Height Range (without worksurface)	Approx. 25" - 50"	Approx. 27" - 47"	Approx. 26" - 40"
Fits table top widths	47" - 75"	47" - 75"	59" - 72"
Fits table top depths	24" - 36"	24" - 36"	24" - 30"
Load Capacity	285 lbs.	250 lbs.	85 lbs.
Colors	Black; Gray	Black; Gray	Black; Gray
Accepts caster (ALE-HT3004)	Yes	Yes	Yes



## Reversible Laminate Table Tops

Take your pick. Multiple sizes and colors to create your own unique desk, table or workstation.

- Reversible table tops have a different color and pattern on each side with coordinating dark gray edge banding.
- Use with Alera® bases to create height adjustable workstations, training tables, collaborative spaces or standard desks.
- Durable laminate is water-, scratch-, and dent-resistant.
- Coordinating colors with Alera® Valencia™ and Open Office Suites.
- Commercial grade, 1" thick top.
- Table tops and bases sold and shipped separately—ORDER BOTH.
- Manufacturer's limited five-year warranty.
- Meets or Exceeds ANSI/BIFMA Standards.

Top and Base sold and shipped separately—ORDER BOTH.

### A REVERSIBLE TABLE TOP

ID No.	Color	W x D	Shpg. Wt.	Unit	Price
<b>Rectangular Top</b>					
1	ALE-TT7230EW Espresso/Walnut	71½" x 29½"	58 lbs.	Each	<del>269.00</del>
2	ALE-TT7230CM Medium Cherry/Mahogany	71½" x 29½"	58 lbs.	Each	<del>269.00</del>
3	ALE-TT7230WG White/Gray	71½" x 29½"	58 lbs.	Each	<del>269.00</del>
4	ALE-TT7224EW Espresso/Walnut	71½" x 23¾"	48 lbs.	Each	<del>199.00</del>
5	ALE-TT7224CM Medium Cherry/Mahogany	71½" x 23¾"	48 lbs.	Each	<del>199.00</del>
6	ALE-TT7224WG White/Gray	71½" x 23¾"	48 lbs.	Each	<del>199.00</del>
7	ALE-TT6030EW Espresso/Walnut	59½" x 29½"	46 lbs.	Each	<del>299.00</del>
8	ALE-TT6030CM Medium Cherry/Mahogany	59½" x 29½"	46 lbs.	Each	<del>299.00</del>
9	ALE-TT6030WG White/Gray	59½" x 29½"	49 lbs.	Each	<del>299.00</del>
10	ALE-TT6024EW Espresso/Walnut	59½" x 23¾"	40 lbs.	Each	<del>169.00</del>
11	ALE-TT6024CM Medium Cherry/Mahogany	59½" x 23¾"	40 lbs.	Each	<del>169.00</del>
12	ALE-TT6024WG White/Gray	59½" x 23¾"	40 lbs.	Each	<del>169.00</del>
13	ALE-TT4824EW Espresso/Walnut	47¾" x 23¾"	33 lbs.	Each	<del>149.00</del>
14	ALE-TT4824CM Medium Cherry/Mahogany	47¾" x 23¾"	33 lbs.	Each	<del>149.00</del>
15	ALE-TT4824WG White/Gray	47¾" x 23¾"	33 lbs.	Each	<del>149.00</del>

### B ALERA® ADAPTIVERGO® CLAMP-ON KEYBOARD TRAY

Smooth movement slide-out tray puts your keyboard right where you need it under your desk for improved ergonomics. Easy to install with sturdy metal clamps on any surface up to 1.5" thick. No screw installation does not damage the worksurface. Impact resistant plastic tray fits most standard and ergonomic keyboards. A great choice when under-desk crossbars, hardware or other obstructions make permanent mount keyboard. Manufacturer's limited five-year warranty.

ID No.	Color	Glide Track Length	Unit	Price
16	ALE-KBT1B Black	9.84"	Each	<del>89.00</del>

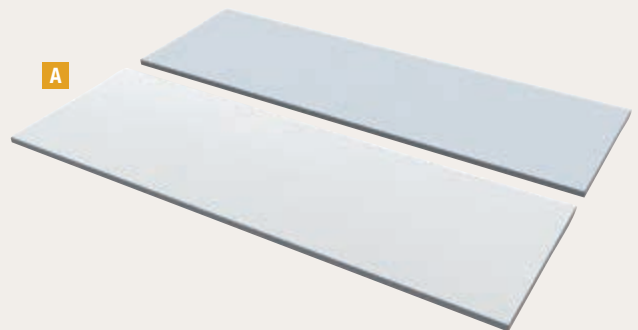

# Sit To Stand Tables

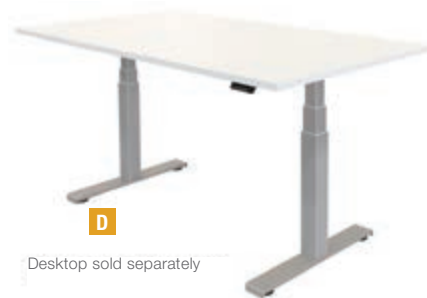

**HON.**

## Coordinate™ Height-Adjustable Desks

Enjoy a healthier workstyle with this HON Coordinate height-adjustable base.

- Add this base to a HON worksurface and raise or lower the desk at the touch of a button, thanks to an electric motor and 3-stage or 2-stage expandable base.
- Backed by the HON Limited Five-Year Warranty.
- Meets or Exceeds ANSI/BIFMA Standards and ISTA Performance Standards.

### A COORDINATE™ HEIGHT-ADJUSTABLE BASES

Top and Base sold separately – order both.

ID No.	Color	W x D x H	Shpg. Wt.	Unit	Price
<b>2-Stage Adjustable Base</b>					
1	HON-HAB2S2LP8L Nickel	72" x 24" x 25.625" to 45.25"	66 lbs.	Each	<del>1,000.00</del>
<b>3-Stage Adjustable Base</b>					
2	HON-HAB3S2LP8L Gray	72" x 24" x 21.625" to 47.75"	66 lbs.	Each	<del>1,120.00</del>

## Foundation™ Worksurfaces

All components feature attractive scratch- and stain-resistant laminate for an unbeatable combination of stunning beauty and rugged durability.

- Get the fundamentals and much more with the HON Foundation laminate collection.
- Worksurfaces are 1½" thick.
- Backed by the HON Limited Five-Year Warranty.
- Meets or exceeds ANSI/BIFMA Standards.

### B RECTANGLE WORKSURFACE (NOT SHOWN)

Can be added to a base to create a fully functional workstation.

Top and Base sold separately – order both.

ID No.	Color	Size	Shpg. Wt.	Unit	Price
3	HON-LMW4824N Mahogany	48" x 24"	61 lbs.	Each	<del>436.00</del>
4	HON-LMW4824PNC Pinnacle	48" x 24"	61 lbs.	Each	<del>436.00</del>
5	HON-LMW4824F Shaker Cherry	48" x 24"	61 lbs.	Each	<del>436.00</del>
6	HON-LMW6024N Mahogany	60" x 24"	75 lbs.	Each	<del>459.00</del>
7	HON-LMW6024PNC Pinnacle	60" x 24"	75 lbs.	Each	<del>459.00</del>
8	HON-LMW6024F Shaker Cherry	60" x 24"	75 lbs.	Each	<del>459.00</del>
9	HON-LMW6030N Mahogany	60" x 30"	92 lbs.	Each	<del>224.00</del>
10	HON-LMW6030PNC Pinnacle	60" x 30"	92 lbs.	Each	<del>224.00</del>
11	HON-LMW6030F Shaker Cherry	60" x 30"	92 lbs.	Each	<del>224.00</del>
12	HON-LMW7224N Mahogany	72" x 24"	89 lbs.	Each	<del>479.00</del>
13	HON-LMW7224PNC Pinnacle	72" x 24"	89 lbs.	Each	<del>479.00</del>
14	HON-LMW7224F Shaker Cherry	72" x 24"	89 lbs.	Each	<del>479.00</del>
15	HON-LMW7230N Mahogany	72" x 30"	110 lbs.	Each	<del>260.00</del>
16	HON-LMW7230PNC Pinnacle	72" x 30"	110 lbs.	Each	<del>260.00</del>
17	HON-LMW7230F Shaker Cherry	72" x 30"	110 lbs.	Each	<del>260.00</del>

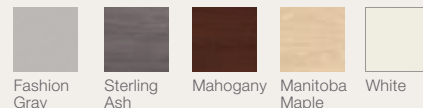

## Fellowes

### C LEVADO™ HEIGHT ADJUSTABLE DESK BASE

Fast 90-Second assembly—simply fold out the legs and lock into place with patent-pending SwiftLok™ design. Intuitive adjustment with premium Feather-Lift™ control paddle, with 4 programmable memory settings. No tool attachment to new or existing work surfaces with optional VersaTop Clamps™ (traditional mounting hardware also included), accommodates tops 48"-72" wide. Adjusts at 1.4" per second with collision detection safety feature - Lifting capacity 220 lbs. Maximum height adjustable with strong and stable 3-Stage legs, adjusting from 24.2" – 48.5" (ADA Compliant). Included cable management. Manufacturer's limited 15-year warranty. BIFMA Tested.

Top and Base sold and shipped separately.

ID No.	Colors	W x D x H	Shpg. Wt.	Unit	Price
18	FEL-9650701 Silver	27.75" x 24.2" to 48.5"	97 lbs.	Each	<del>1,249.99</del>

### D CAMBIO™ HEIGHT ADJUSTABLE DESK BASE

Easily go from sitting to standing with handset that features three programmable memory settings. Accommodates tops 48" to 72" wide. Maximum height adjustability with 3-stage legs, 24.75" to 50.25". Collision detection safety feature. Adjusts at 1.4" per second, lifting capacity 176 lbs. Included cable management. 9 ft. cord with side access to the left.

Top and Base sold and shipped separately.

ID No.	Colors	W x D x H	Shpg. Wt.	Unit	Price
19	FEL-9682001 * Silver	72" x 30" x to 50.25"	78 lbs.	Each	<del>814.99</del>

\* cUL; uL. Base and top sold and shipped separately.

### E LEVADO™ LAMINATE TABLE TOP

Pair your height-adjustable base with a high-pressure, 1½" thick laminate top for easy cleaning and designed to be resistant to dents, chips, UV rays, stains and scratches. Compatible with Fellowes® Levado™ Height Adjustable Table Base. Manufacturer's limited five-year warranty.

Top and Base sold separately – order both.

ID No.	Colors	Worksurface Dimensions	Shpg. Wt.	Unit	Price
20	FEL-9649601 Fashion Gray	72" x 30"	82 lbs.	Each	<del>374.99</del>
21	FEL-9650201 Sterling Ash	72" x 30"	82 lbs.	Each	<del>374.99</del>
22	FEL-9650601 Mahogany	72" x 30"	82 lbs.	Each	<del>374.99</del>
23	FEL-9649901 Manitoba Maple	72" x 30"	82 lbs.	Each	<del>374.99</del>
24	FEL-9649301 White	72" x 30"	82 lbs.	Each	<del>374.99</del>
25	FEL-9649501 Fashion Gray	60" x 30"	69 lbs.	Each	<del>309.99</del>
26	FEL-9650101 Sterling Ash	60" x 30"	69 lbs.	Each	<del>309.99</del>
27	FEL-9650501 Mahogany	60" x 30"	69 lbs.	Each	<del>309.99</del>
28	FEL-9649801 Manitoba Maple	60" x 30"	69 lbs.	Each	<del>309.99</del>
29	FEL-9649201 White	60" x 30"	69 lbs.	Each	<del>309.99</del>
30	FEL-9649401 Fashion Gray	48" x 24"	45 lbs.	Each	<del>249.99</del>
31	FEL-9650001 Sterling Ash	48" x 24"	45 lbs.	Each	<del>249.99</del>
32	FEL-9650401 Mahogany	48" x 24"	45 lbs.	Each	<del>249.99</del>
33	FEL-9649701 Manitoba Maple	48" x 24"	45 lbs.	Each	<del>249.99</del>
34	FEL-9649101 White	48" x 24"	45 lbs.	Each	<del>249.99</del>



## A WORKFIT TX STANDING DESK CONVERTER

Don't settle for half best. Get an ergonomic fit no matter how you work; sitting or standing. The X-shaped lift lowers within inches of your desktop to give you the right monitor to keyboard tray spacing that lets you WorkFit. With an adjustable, drop-down keyboard tray, this ultra-low standing desk converter delivers advanced ergonomics and style out-of-the-box. Manufacturer's five-year warranty.

ID No.	Colors	W x D x H	Shpg. Wt.	Unit	Price
1 ERG-33467921	Black	36.6" x 33" x up to 19"	76 lbs.	Each	<del>990.00</del>

## WorkFit Sit-Stand Workstations

Enjoy standing or sitting as you work, switching positions whenever you choose.

- Patented Constant Force™ lift technology.
- Modify existing office spaces or cubes by simply clamping it on an existing worksurface edge.

## B WORKFIT-T SIT-STAND DESKTOP WORKSTATION

Presenting an ultra easy standing desk solution, which quickly converts a tabletop into a healthy sit-stand workstation. Simply place the WorkFit-T on an open surface and you're ready to work! WorkFit-T saves space because it moves straight up and down, always staying within the footprint of your desktop. The platform is extremely stable throughout its range of motion—one can freely lean on it while working without worry of tip or height-drop.

ID No.	Colors	W x D x H	Shpg. Wt.	Unit	Price
2 ERG-33397085	Black	35" x 22" x up to 20"	59 lbs.	Each	<del>795.00</del>
3 ERG-33397062	White	35" x 22" x up to 20"	59 lbs.	Each	<del>795.00</del>

## C WORKFIT-TL SIT-STAND DESKTOP WORKSTATION

Presenting an ultra easy standing desk solution, which quickly converts a tabletop into a healthy sit-stand workstation. Simply place on an open surface and you're ready to work! Features a larger keyboard tray, wider worksurface and higher weight capacity than the smaller WorkFit-T. Saves space because it moves straight up and down, always staying within the footprint of your desktop. Extremely stable throughout its range of motion, one can freely lean on it while working without worry of tip or height-drop. Modify an existing office space or cubicle by simply adding a WorkFit-TL to an open tabletop, without the cost of expensive professional installers. Ships fully assembled. Sits directly on top of desk—no special mounting or tool-adjustments required for installation. Provides 15 inches of vertical adjustment. Instantly move to sit or stand as you work: Simply release hand-brake levers on either side of unit to position the surface higher or lower. No cranks or motors to engage: Counterbalancing mechanism uses CF™ technology to facilitate quick height adjustment. Works well in corner desk configurations; fits on surfaces as shallow as 19".

ID No.	Colors	W x D x H	Shpg. Wt.	Unit	Price
4 ERG-33406085	Black	37½" x 25" x up to 20"	62 lbs.	Each	<del>895.00</del>
5 ERG-33406062	White	37½" x 25" x up to 20"	62 lbs.	Each	<del>895.00</del>

## D MONITOR RISER

Upgrade your WorkFit™ to hold your screen above the desktop. Offers 5" (13 cm) of height adjustment. Easily lift screens to proper height for Ergonomic comfort.

ID No.	For Monitors (Size, Weight)	Weight	Unit	Price
<b>Single</b>				
6 ERG-97935085	Up to 24", 6 to 16 lbs.	6.6 lbs	Each	<del>485.00</del>
7 ERG-97934085	Up to 24", 16 to 28 lbs.	9.7 lbs	Each	<del>270.00</del>
<b>Double</b>				
8 ERG-979339085	Up to 24", 6 to 16 lbs.	10.1 lbs	Each	<del>275.00</del>



new



## E COORDINATE™ PORTABLE DESKTOP RISER

The spacious work surface and separate keyboard tray sits on top of your existing table or desk. Slot on upper worksurface holds a tablet or mobile device. Backed by the HON Limited Five-Year Warranty. Meets or Exceeds ISTA Performance Standards.

ID No.	Colors	W x D x H	Shpg. Wt.	Unit	Price
9 BSX-RISERBLK	Black	35.04" x 31.1" x 4½" to 16.54"	54 lbs.	Each	<del>649.00</del>
10 BSX-RISERWHT	White	35.04" x 31.1" x 4½" to 16.54"	54 lbs.	Each	<del>649.00</del>

Prices subject to change without notice. Visit our website for the latest pricing and product information.



# Sit To Stand Computer Furniture



## A ADAPTIVERGO® SIT-STAND WORKSTATION

Get more active and productive by giving yourself the option to now stand at your existing desk. Large surface area accommodates all your desktop items including monitors, a keyboard, a mouse and documents. Smooth lifting and height adjustable up to 20". Two-tiered surface puts your keyboard lower where you need it. Notched back can accommodate most standard monitor arm kits. Smart ergonomic design lifts and lowers within the same plane on your desk surface, so you do not need to step back and away in standing position. Durable steel base construction for long-lasting performance. Non-skid silicone pads protect your work surface from scuffs and scratches. High-quality top surface is water- and dent-resistant. Ready out of the box so no installation required. Manufacturer's limited five-year warranty. Meets or Exceeds ANSI/BIFMA Standards.

ID No.	Colors	W x D x H	Shpg. Wt.	Unit	Price
1	ALE-AEWR4B	Black	37 $\frac{3}{4}$ " x 26 $\frac{1}{2}$ " x 4 $\frac{1}{4}$ " to 19 $\frac{1}{2}$ "	46 lbs.	Each <del>439.00</del>
2	ALE-AEWR3B	Black	31 $\frac{1}{2}$ " x 26 $\frac{1}{2}$ " x 4 $\frac{1}{4}$ " to 19 $\frac{1}{2}$ "	42 lbs.	Each <del>379.00</del>

## B ADAPTIVERGO® ULTRA-SLIM SIT-STAND DESK

A sleek and modern sit-to-stand lifting desk when both form and function matter. Ergonomic and smart control levers make lifting and lowering easy. Be more active, healthy and productive. Height adjustable up to 15". Durable steel base construction for long-lasting performance. Non-skid silicone pads protect your work surface from scuffs and scratches. High-quality top surface is impact- and water-resistant. Ready out of the box so installation required. Manufacturer's limited five-year warranty. Meets or Exceeds ANSI/BIFMA Standards.

ID No.	Colors	W x D x H	Shpg. Wt.	Unit	Price
3	ALE-AEWR6B	Black	31 $\frac{1}{2}$ " x 21 $\frac{3}{4}$ " x 1 $\frac{1}{2}$ " to 16"	28 lbs.	Each <del>309.00</del>

## C ADAPTIVERGO® LAPTOP LIFTING WORKSTATION

Ideal for laptops and perfect for small spaces, homes and personal offices. Aluminum base construction provides a sleek, lighter and elegant look. Slim height adjustable laptop desk turns any space into an adjustable height sit to stand workstation. Raise and lower with ease within a 14 $\frac{1}{2}$ " range. Raises and lowers vertically within the same plane so there's no need to step back and out when in the raised position. Non-skid rubber pads protect work surface from scratches or scuffs. Lightweight (less than 15 lb) and compact design allows for easy storage when not in use. Manufacturer's limited five-year warranty. Meets or Exceeds ANSI/BIFMA Standards.

ID No.	Colors	W x D x H	Shpg. Wt.	Unit	Price
4	ALE-AEWR7B	Black/Silver	31 $\frac{1}{4}$ " x 12 $\frac{3}{4}$ " x 1 $\frac{1}{4}$ " to 16"	17 lbs.	Each <del>299.00</del>

## AdaptivErgo® Monitor Arm

Strong durable construction withstands the rigors of the busy office.

- Easy to install clamp or grommet mounting fits desk up to 4" thick and grommets up to 2 $\frac{3}{4}$ " in diameter.
- Saves valuable desk space.
- Fits most standard desks as well as Alera® AdaptivErgo® Sit-Stand Workstations.
- VESA MIS-D Compliant.

## D HEAVY-DUTY ARTICULATING MONITOR ARM WITH USB

ID No.	For Monitors (Size, Weight)	Unit	Price
<b>Single Monitor</b> —Also includes two USB ports.			
5	ALE-AEMA1H Up to 27", up to 11 lbs.	Each	<del>229.00</del>
<b>Dual Monitors</b> —Also includes two USB and audio ports.			
6	ALE-AEMA2H Up to 27", up to 11 lbs. per arm.	Each	<del>479.00</del>
<b>Triple Monitors</b> —Also includes two USB and audio ports.			
7	ALE-AEMA3H Up to 32", up to 15.4 lbs per arm	Each	<del>679.00</del>

## E POLE-MOUNTED MONITOR ARM

ID No.	For Monitors (Size, Weight)	Unit	Price
<b>Single Monitor</b>			
8	ALE-AEMA1B Up to 30", up to 22 lbs.	Each	<del>199.00</del>
<b>Dual Monitors</b>			
9	ALE-AEMA2B Up to 30", up to 22 lbs. per arm.	Each	<del>289.00</del>
<b>Triple Monitors</b>			
10	ALE-AEMA3B Up to 27", up to 17.6 lbs. per arm.	Each	<del>379.00</del>

## ergotron

### F LX DUAL DIRECT MONITOR ARM

Create a fully adjustable side-by-side monitor set-up that lifts both LCD screens simultaneously. The monitor arm makes it easier to see your screens while letting you make the most of valuable workspace. Manufacturer's ten-year warranty. VESA MIS-D Compliant.

ID No.	For Monitors (Size, Weight)	Weight	Unit	Price
11	ERG-45489224 Up to 25", up to 11 lbs. each	15.5 lbs.	Each	<del>525.00</del>
12	ERG-45489026 Up to 25", up to 11 lbs. each	15.5 lbs.	Each	<del>525.00</del>



### A ADAPTIVERGO® ANTI-FATIGUE MAT

Encourage proper ergonomics and reduce fatigue with this cushioned standing mat. Beveled edge lays flat on the floor to reduce trip hazards. Rubber and vinyl construction ensures long lasting resiliency and cushioning. Ideal for use at sit-to-stand workstations, service counters, breakrooms, or wherever standing is required. Easy to clean surface with molded grid pattern to catch dirt and spills. Combine with Alera® AdaptivErgo® Height Adjustable Tables or Alera® AdaptivErgo® Lifting desks for even more ergonomic benefits with your sit-to-stand workstations. Manufacturer's limited five-year warranty.

ID No.	Color	W x L	Qty.	Unit	Price
1	ALE-AE23AFM	Black	24" x 36"	1	Each <del>99.00</del>



### B ADAPTIVERGO® SIT-STAND LIFTING WORKSTATION

These lifting workstations turn any desk into an ergonomic sit-stand station. Raise and lower with ease within a 14" range by simply pressing the levers on each side to engage. Two-tiered worksurface and keyboard/mouse platform for better ergonomics. Platform's rear-notched design accommodates most monitor arms and is helpful for cable management. Designed specifically for use with the Alera® Monitor Arms. Smart space-saving design stays within your desk space and raises vertically within the same plane. No having to step back and out when in the raised position. Reinforced base for stability at any height. Will not flip or height-drop, even when leaning on the workstation. Manufacturer's limited five-year warranty. Meets or Exceeds ANSI/BIFMA Standards.

ID No.	Colors	Worksurface Dimensions	Total Weight Capacity	Shpg. Wt.	Unit	Price
2	ALE-AEWR2B	Black	35 1/4" x 23 3/4"	35 lbs.	63 lbs.	Each <del>559.00</del>
3	ALE-AEWR1B	Black	26 3/4" x 23 1/4"	35 lbs.	55 lbs.	Each <del>475.00</del>

### C ADAPTIVERGO® HEAVY-DUTY ARTICULATING MONITOR ARM WITH USB

Strong durable construction withstands the rigors of the busy office. Easy-to-install clamp or grommet mounting fits desk up to 4" thick and grommets up to 2 3/4" in diameter. Saves valuable desk space. Fits most standard desks as well as Alera® AdaptivErgo® Sit-Stand Workstations. VESA MIS-D Compliant.

ID No.	For Monitors (Size, Weight)	Unit	Price
<b>Dual Monitors</b> —Also includes two USB and audio ports.			
4	ALE-AEMA2H	Up to 27", up to 11 lbs. per arm.	Each <del>479.00</del>

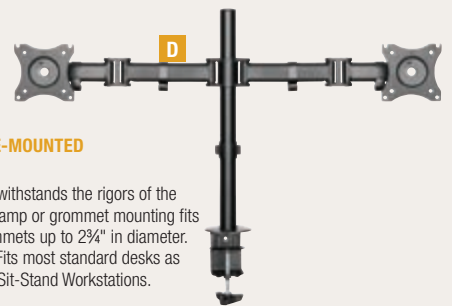

### D ADAPTIVERGO® POLE-MOUNTED MONITOR ARM

Strong durable construction withstands the rigors of the busy office. Easy-to-install clamp or grommet mounting fits desk up to 4" thick and grommets up to 2 3/4" in diameter. Saves valuable desk space. Fits most standard desks as well as Alera® AdaptivErgo® Sit-Stand Workstations. VESA MIS-D Compliant.

ID No.	For Monitors (Size, Weight)	Unit	Price
<b>Dual Monitors</b>			
5	ALE-AEMA2B	Up to 30", up to 22 lbs. per arm.	Each <del>299.00</del>



## AdaptivErgo® Perch Stool

Advanced active ergonomics goes from sitting to standing with ease.

- Pivoting angled column moves with the body for constant alignment.
- Perch or lean when you wish to perform fast tasks or fully sit down when you wish to concentrate on more complicated tasks.
- Goes from sitting height to standing height; perfect for use with height adjustable workstations.
- Auto return swivel seat moves with the body as you twist, and returns to front automatically when you get up.
- Dual integrated height adjustment levers for quick adjustments with either hand.
- Wide boomerang base for stability when leaning far forward.
- Manufacturer's limited five-year warranty.
- Meets or Exceeds ANSI/BIFMA Standards.

### E SIT TO STAND PERCH STOOL

Supports up to 250 lbs. Seat: 14.25" x 13.75". Overall height: 25.63" to 36.5".

ID No.	Base Color	Shpg. Wt.	Unit	Price
<b>Black Base</b>				
6	ALE-AE35PSBK	Black	22 lbs.	Each <del>975.00</del>

Prices subject to change without notice. Visit our website for the latest pricing and product information.

# Sit To Stand Computer Furniture

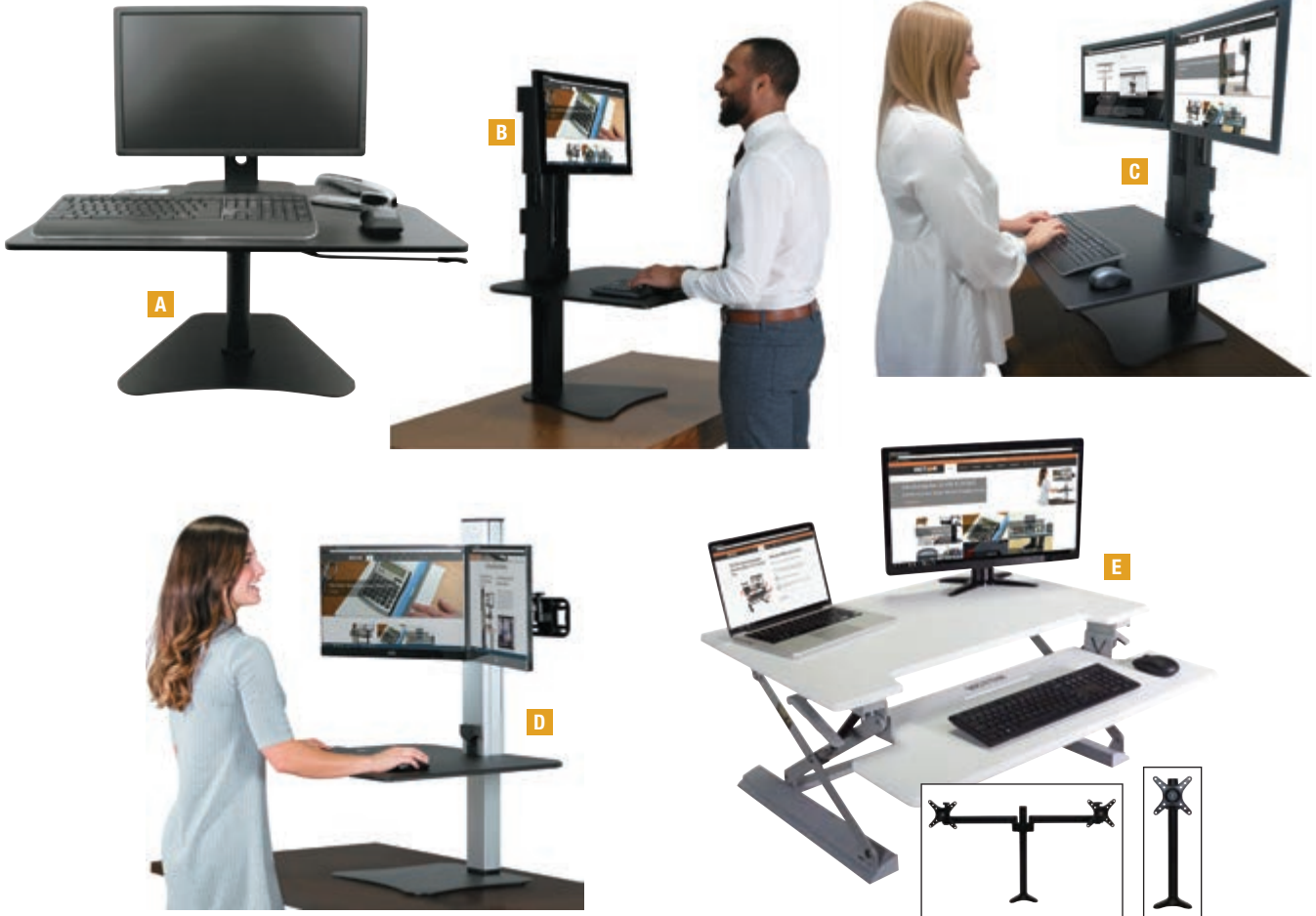

**VICTOR**

## High Rise™ Collection

Simple solution to a common workplace problem: too much sitting.

- Sleek wood construction and a durable laminate coating.
- Manufacturer's limited 3-year warranty.

### A DC200 HIGH RISE™ COLLECTION ADJUSTABLE STAND-UP DESK CONVERTER

Transforms any sit-down desk into a stand-up desk. Surface is raised 12" to 16¾" for ergonomic placement of your office equipment and supplies. Gas strut design allows easy custom height adjustments with the pull of a lever. Back is notched to help manage cables. Heavy steel base prevents tipping. Add optional DC050 Monitor Stand to raise your computer display to an ergonomic height while standing. Does not lower to sitting position.

ID No.	Colors	W × D × H	Shpg. Wt.	Unit	Price
1 VCT-DC200	Black	28" × 23" × 12" to 16¾"	27 lbs.	Each	<del>489.99</del>

### B DC300 HIGH RISE™ MANUAL SINGLE MONITOR STANDING DESK WORKSTATION

Transforms any sit-down desk into either a sit or stand desk. Surface is raised up to 15½" for ergonomic placement of your office equipment and supplies. Gas strut design allows easy custom height adjustment of both desk and monitor with the twist of a knob. Monitor holder is also height-adjustable. Heavy steel base prevents tipping.

ID No.	Colors	W × D × H	Shpg. Wt.	Unit	Price
2 VCT-DC300	Black	28" × 23" × 0" to 15½"	40 lbs.	Each	<del>449.99</del>

### C DC35 HIGH RISE™ MANUAL DUAL MONITOR STANDING DESK WORKSTATION

Transforms any sit-down desk into either a sit or stand desk. Surface is raised up to 15½" for ergonomic placement of your office equipment and supplies. Gas strut design allows easy custom height adjustment of both desk and monitors with the twist of a knob. Monitor holder accommodates two monitors and is also height-adjustable. Heavy steel base prevents tipping.

ID No.	Colors	W × D × H	Shpg. Wt.	Unit	Price
3 VCT-DC350	Black	28" × 23" × 0" to 15½"	45 lbs.	Each	<del>524.99</del>

### D DC450 HIGH RISE™ ELECTRIC DUAL MONITOR STANDING DESK WORKSTATION

Transforms any sit-down desk into a sitting or stand-up desk. The 28" wide by 23" deep surface is raised up to 20" for ergonomic placement of monitor, keyboard, mouse, telephone and papers while standing. Electric motor design allows easy custom height adjustment with the push of a button. The monitor holder is also height-adjustable with a range of 12.5". Safety sensor stops movement when obstacles are detected under the desk. The sturdy steel base and aluminum tower are built to last. This standing desk converter rests on top of any desk or table. Holds two monitors up to 27" wide and up to 12.5 lbs each. Standard VESA mounting holes are required.

ID No.	Colors	W × D × H	Shpg. Wt.	Unit	Price
4 VCT-DC450	Black/Aluminum	28" × 23" × 7.75" to 20.25"	45 lbs.	Each	<del>749.74</del>

### E HIGH RISE™ HEIGHT ADJUSTABLE STANDING DESK WITH KEYBOARD TRAY

Transforms any standard sit-down desk into a sitting or standing desk. It sits on top of your current desk or table and does not require clamping or attachment of any kind. Simply go from sitting to standing with an easy squeeze of the lever handles on each side of the work surface. Perfect for any environment, it can be used in the home, professional office or industrial work places. The large, deep desk surface is accompanied by a wide and deep keyboard tray. Provides an ergonomic working position for users of varied heights. Manufacturer's limited three-year warranty.

ID No.	Colors	W × D × H	Shpg. Wt.	Unit	Price
5 VCT-DCX760	Gray/Black	36" × 31¼" × 5¼" to 21"	60 lbs.	Each	<del>517.49</del>
6 VCT-DCX710	Gray/Black	31" × 31¼" × 5¼" to 21"	49 lbs.	Each	<del>494.49</del>





White Black



## A PRECISION STANDING DESK

Provides maximum adjustability to achieve your most comfortable standing work position. Side-mounted levers control gas-assisted continuous height adjustment to move smoothly and quietly between sitting and standing positions from 6.2" to 20" above the desk surface. The keyboard surface has tilt adjustment range of -10°/+10° to help achieve your most comfortable typing position. Includes a 3M™ Gel Wrist Rest and Precise™ Mouse Pad for added comfort and productivity. Supports up to 45 lbs.

ID No.	Colors	W x D x H	Shpg. Wt.	Unit	Price
1	MMM-SD70B	Black	42" x 23.2" x 6.2" to 20"	55 lbs. Each	<del>446.00</del>



## B LAPTOP TABLE

Single workstation for laptop use. Rubberwood Top. Supports up to 10 lbs. evenly distributed. Manufacturer's limited lifetime warranty.

ID No.	Color	Size	Shpg. Wt.	Unit	Price
2	SAF-5065NA	Natural	19½" x 15" x 29"	13 lbs. Each	<del>104.00</del>



## High Rise™ Collection

Simple solution to a common workplace problem: too much sitting.

- Sleek wood construction and a durable laminate coating.
- Manufacturer's limited 3-year warranty.

## C DC050 HIGH RISE™ MONITOR RISER

Raises your computer display to an ergonomic height. The 27" wide by 11.5" deep surface is 6.5" tall to enable eye-level viewing. Optional height extenders add an additional 1". Sleek wood construction and a durable laminate coating provide years of use with a modern style. The rear portion of the desk is tapered to fit corner cubicles and notched to help manage cables. The lower shelf stores books, papers, or accessories.

ID No.	Color	W x D x H	Unit	Price	
3	VCT-DC050	Black	27" x 11½" x 6½" to 7½"	Each	<del>103.49</del>

## D DC100 HIGH RISE™ STAND-UP DESK CONVERTER

Transforms any sit-down desk into a stand-up desk. Surface is raised 12½" or 14½" for ergonomic placement of your office equipment and supplies. Lower shelf stores books, papers or accessories. Back is notched to help manage cables. Also works well as a stand for everyday office equipment. Add optional DC050 Monitor Stand to raise your computer display to an ergonomic height while standing.

ID No.	Colors	W x D x H	Shpg. Wt.	Unit	Price
4	VCT-DC100	Black	28" x 23" x 12½" to 14½"	16 lbs. Each	<del>119.99</del>

## E DC230B HIGH RISE™ ADJUSTABLE LAPTOP STAND

Standing while working on your laptop or tablet becomes a breeze. Simple design and sturdy wood and steel construction, this ergonomic option allows for maximum workspace with a small footprint. The scratch-resistant PVC coated worksurface allows for the space to work comfortably and accommodate a mouse, a cup of coffee or a 4 x 6 notepad. With a lever directly under the work surface, adjusting the height is simple and smooth. The heavy-duty steel piston allows for height adjustments from 12" to 15¾" above the desk or tabletop. Note: Does not lower to a sitting position. Create a standing work station virtually anywhere that meets the demand of your busy day. Portable and easy to move.

ID No.	Color	W x D x H	Unit	Price	
5	VCT-DC230B	Black	21" x 13" x 15¾"	Each	<del>114.99</del>



## F DESKTOP SIT/STAND WORKSTATIONS

Adjustable sit-to-stand workstation is designed to retrofit to work surfaces up to 3" thick. Made from steel and aluminum with a powder coat finish. Monitor arm supports up to 11 lbs., is VESA compatible, attaches by C-clamp to the back edge of your desk or table and provides cable management. Monitor and keyboard tray height are individually adjustable, and the workstation offers monitor tilt adjustment to help alleviate eye-strain. All height adjustments are made manually, and the entire assembly swivels left and right for desktop access. The adjustable keyboard tray is extendible/retractable, and is rubber-coated and textured to help hold the keyboard securely in place. Allows for right- or left-handed use. Manufacturer's limited lifetime warranty.

ID No.	For Monitors (Size, Weight)	Height	Unit	Price	
<b>Single Monitor</b>					
6	SAF-2130SL	Up to 11 lbs.	18½"	Each	<del>400.00</del>
<b>Laptop</b>					
7	SAF-2132SL	Up to 11 lbs.	20"	Each	<del>340.00</del>

Prices subject to change without notice. Visit our website for the latest pricing and product information.

# Sit To Stand Tables



## WorkFit-D Sit-Stand Desk

Encourages healthy movement throughout the day for prolonged computing comfort.

- Enjoy sitting or standing as you work, switching positions whenever you choose.
- Pre-drilled to accept Ergotron® NeoFlex® Underdesk Keyboard Arm.
- Add an Ergotron® LX LCD Arm as needed to accommodate individual workflows.

### A WORKFIT-D SIT-STAND DESK

Prolonged computing comfort is yours with this height-adjustable ergonomic desk. Patented Constant Force (CF) technology provides 20" of effortless lift, allowing you to move from a sitting to a standing position whenever you like. Safe and easy to use with simple installation and operation. Robust 65-lb. weight capacity; accommodates multiple displays, keyboards, books, phones, etc.

ID No.	Colors	W x D x H	Shpg. Wt.	Unit	Price
1	ERG-24271928 Birch/Black	47% <sup>1</sup> x 23½ <sup>2</sup> x 30% <sup>3</sup> to 50% <sup>4</sup>	108 lbs.	Each	<del>1,415.00</del>
2	ERG-24271927 Walnut/Black	47% <sup>1</sup> x 23½ <sup>2</sup> x 30% <sup>3</sup> to 50% <sup>4</sup>	108 lbs.	Each	<del>1,415.00</del>

## WorkFit-C Sit-Stand Workstation

Enables an effortless sit-and-stand work style.

- Truly ergonomic platform for prolonged computing.
- Switch positions whenever you choose.
- Mobile configuration brings flexibility into the workspace.
- Expansive cable management storage area.
- Manufacturer's five-year warranty.
- VESA MIS-D Compliant.

### B WORKFIT-C SIT-STAND WORKSTATION

Fully functional computer cart that doubles as a mobile stand up desk, featuring a large desktop and a height-adjustable working platform that places your laptop alongside a monitor. Easily and simultaneously lift keyboard and LCD screen to proper height for unsurpassed ergonomic comfort. Open-architecture design is scalable for future computer equipment.

ID No.	Colors	W x D x H	Shpg. Wt.	Unit	Price
<b>Single HD</b>					
3	ERG-24216085 Black/Gray	36¼ <sup>1</sup> x 32¼ <sup>2</sup> x 44¼ <sup>3</sup> to 49¼ <sup>4</sup>	86 lbs.	Each	<del>1,530.00</del>



ergotron

### C NEO-FLEX® UNDERDESK KEYBOARD ARM

Ideal for any word-processing office application, this underdesk arm allows you to lift, lower and tilt your keyboard, offering optimum comfort for a wide range of users. Single knob adjustment for both height and tilt settings. One-piece phenolic tray stores conveniently under worksurface when not in use; extends and retracts on smooth ball bearing slides. Accommodates both larger ergonomic keyboards and mouse equipment. Easy and flexible installation; clamp inconspicuously to front edge of ¾" to 1-½" worksurface or remove clamp and attach under the surface with four screws. Combine with the WorkFit-D Sit-Stand Desk to create a complete ergonomic desktop solution.

ID No.	Weight	Unit	Price
4	ERG-97582009	3 lbs.	Each <del>250.00</del>

### D LEARNFIT SE SIT-STAND DESK, SHORT

Manufacturer's ten-year warranty. Meets ANSI/BIFMA X5.5-2014 Standard.



ID No.	Colors	W x D x H	Shpg. Wt.	Unit	Price
5	ERG-24687057 Gray	24" x 20¼" x 29" to 45"	31 lbs.	Each	<del>560.00</del>

### E LEARNFIT™ ADJUSTABLE STANDING DESK

Transform classrooms into active learning environments with on-demand adjustable student desks. With the simple use of a hand lever, students can change the height of their desktops so that they can work and collaborate in the way that is natural for them. Casters easily roll to reconfigure classrooms for small-group breakouts and quickly return to full classroom configuration when done. Manufacturer's ten-year warranty. ANSI/BIFMA X5.5-2008 Compliant.



ID No.	Colors	W x D x H	Shpg. Wt.	Unit	Price
--------	--------	-----------	-----------	------	-------

### PrecisionHeight™ Technology Lift Mechanism

6	ERG-24481003 White/Silver	24" x 22" x 33¼" to 49¼"	40 lbs.	Each	<del>655.00</del>
---	---------------------------	--------------------------	---------	------	-------------------

VICTOR

## High Rise™ Collection

Simple solution to a common workplace problem: too much sitting.

- Sleek wood construction and a durable laminate coating.
- Manufacturer's three-year warranty.

### F DC500 MOBILE ADJUSTABLE STANDING DESK WORKSTATION

Gives you the ergonomic benefits of a sit-to-stand desk plus the mobility of a cart. Wherever you need to go, your desk can follow. Rising to 44" and lowering to 29", the standard sitting height, this workstation provides the perfect ergonomic solution to your adjustable desk needs. The large work surface can accommodate a computer, keyboard and desktop necessities such as files, notes, calculator, or phone. Multi-functional table can be used in multiple settings, including office, classroom, production set, crafting, workshop, warehouse, flea market, lecture, healthcare, and any other application where mobility and variable height adjustment helps get the job done.

ID No.	Colors	W x D x H	Shpg. Wt.	Unit	Price
7	VCT-DC500 Black	30¾" x 22" x 29" to 44"	26 lbs.	Each	<del>287.49</del>



**Fellowes**

### A LOTUS™ SIT-STANDS WORKSTATIONS

The Lotus™ Sit-Stand Workstation makes it effortless to add movement to your workday for improved wellness. Patent-pending Smooth Lift Technology™ keeps your workstation stable and makes changing positions effortless. Features 22 different height settings and 17" of vertical adjustment so you can work in a position that's perfect for you. Innovative cord management and device charging slot allow your entire workspace to move freely with you. Arrives fully assembled - no complicated instructions, no mounting, just unpack and get started. Compatible with Fellowes® Lotus™ Monitor Arm Kits-not included. Manufacturer's five-year warranty. BIFMA Tested. Holds up to 35 lbs.

ID No.	Colors	W x D x H	Shpg. Wt.	Unit	Price
1	FEL-0007901	Black	32.75" x 24.25" x 5.5" to 22.5"	60 lbs.	Each <del>729.99</del>
2	FEL-0009901	White	32.75" x 24.25" x 5.5" to 22.5"	60 lbs.	Each <del>729.99</del>

### B LOTUS™ DX SIT-STAND WORKSTATIONS

Built-in charging station with wireless charging stand that makes staying productive effortless. Patent-pending Smooth Lift Technology™ keeps your workstation stable and makes changing positions effortless. Contains Microban® antimicrobial technology for powerful, continuous product protection against bacteria. Features 22 different height settings and 17" of vertical adjustment so you can work in a position that is perfect for you. Innovative cord management with rear USB ports for your keyboard and mouse allows your entire workspace to move freely with you. Integrated 2-port USB charging station also features wireless charging for Qi-enabled devices. Arrives fully assembled - no complicated instructions, no mounting, just unpack and get started. Holds up to 35 lbs. Compatible with Fellowes® Lotus™ Monitor Arm Kits-not included. Manufacturer's limited five-year warranty. BIFMA Tested.

ID No.	Colors	W x D x H	Shpg. Wt.	Unit	Price
3	FEL-8080301	Black	32.75" x 24.25" x 5.5" to 22.5"	60 lbs.	Each <del>879.99</del>
4	FEL-8080201	White	32.75" x 24.25" x 5.5" to 22.5"	60 lbs.	Each <del>879.99</del>

### C LOTUS™ MONITOR ARM KIT

Raises monitors to an optimal viewing height to prevent neck strain and free up valuable workspace. Easy to mount using the built-in grommet hole, enabling quick set-up. Height adjusts up to 16" above the top surface of a Lotus™ or Lotus™ DX Sit-Stand Workstation. Meets VESA mounting standards. Manufacturer's limited five-year warranty.

ID No.	For Monitors (Size, Weight)	Unit	Price
<b>Single Monitor Arm Kit</b> —Accommodates a single monitor up to 27" and 17lbs.			
5	FEL-8042801	26", up to 17 lbs.	Each <del>197.49</del>
<b>Dual Monitor Arm Kit</b> —Accommodates two monitors up to 27" and 13lbs. and provides up to 12½" of reach.			
6	FEL-8042901	Up to 26", up to 13 lbs.	Each <del>174.99</del>

### D LOTUS™ VE SIT-STAND WORKSTATION

Smooth Lift Technology™ allows you to effortlessly transition from sitting to standing. Dual work surfaces offer useful space and stability to support all of your essentials. Convenient channel keeps all your devices at your fingertips. Integrated cord management keeps your desk free of tangled cords. Features 15" of vertical adjustment so you can work in a position that's perfect for you. The single clamp design with limited installation can be mounted to the back edge of any work surface. (1" – 3-½"). Accommodates monitors up to 20 lbs. with 25 lbs. of total weight capacity. Manufacturer's five-year warranty. BIFMA Tested.

ID No.	Colors	W x D x H	Shpg. Wt.	Unit	Price
<b>Single Monitor Workstation</b>					
7	FEL-8080101	Black	29" x 28.5" x up to 42.5"	62 lbs.	Each <del>574.99</del>
<b>Dual Monitor Workstation</b>					
8	FEL-8082001	Black	29" x 28.5" x up to 42.5"	66 lbs.	Each <del>669.99</del>

**WORKFIT**  
by ergotron

## WorkFit Sit-Stand Workstations

Enjoy standing or sitting as you work, switching positions whenever you choose.

- Patented Constant Force™ lift technology.
- Modify existing office spaces or cubes by simply clamping it on an existing worksurface edge.
- Manufacturer's five-year warranty.

### E WORKFIT-S SIT-STAND WORKSTATION

Promotes proper ergonomic positioning and inspires an on demand sit-stand work routine. The unit offers base height adjustment, individual display adjustment and a back-tilt keyboard tray. Easily and simultaneously lift LCD screens to proper height for unsurpassed ergonomic comfort. The included worksurface provides ample space. Simply clamps onto existing worksurface ¾" to 2½" thick. VESA MIS-D Compliant.

ID No.	Colors	Worksurface Dimensions	Total Weight Capacity	Shpg. Wt.	Unit	Price
<b>Dual LCD Monitors with Worksurface+</b> —Holds two LCD monitors up to 24" each.						
9	ERG-33349211	White	23" x 14½"	25 lbs.	44 lbs.	Each <del>1,050.00</del>
10	ERG-33349200	Polished Aluminum/Black	23" x 15"	25 lbs.	44 lbs.	Each <del>1,050.00</del>
<b>LCD HD Monitor with Worksurface</b> —Holds one LCD HD monitor up to 30".						
11	ERG-33351200	Polished Aluminum/Black	15" x 23"	29 lbs.	44 lbs.	Each <del>1,015.00</del>
<b>LCD LD Monitor with Worksurface</b> —Holds one LCD LD monitor up to 24".						
12	ERG-33350200	Polished Aluminum/Black	15" x 23"	18 lbs.	44 lbs.	Each <del>965.00</del>

### F LOTUS™ LT SIT-STAND WORKSTATION

Easily transition from sitting to standing with gas spring height adjustment. Flexible set up; spacious top platform holds two monitors, or a monitor and laptop and the bottom level perfectly hold a keyboard and mouse. Keep your phone or other accessories within reach with the convenient device channel on top platform. Arrives fully assembled – no complicated instructions, no mounting; just unpack and get started. Work comfortably sitting or standing with 15.5" of adjustment range. Compatible with our Sit-Stand Single and Dual Monitor Arm Kit. Full Dimensions: 31.5" W x 24.2" D, Keyboard Dimensions: 31.3" W x 11.8" D. Three Year Limited Warranty.

ID No.	Colors	W x D x H	Shpg. Wt.	Unit	Price
13	FEL-8215001	Black	34.38" x 28.38" x up to 7.62"	37 lbs.	Each <del>409.99</del>

\* BIFMA Tested.

Prices subject to change without notice.  
Visit our website for the latest pricing and product information.



# Sit To Stand Computer Furniture



**Fellowes**

## A LOTUS™ RT SIT-STAND WORKSTATIONS

Ultimate flexibility with TriMotion™: 180° rotation at the base, 180° worksurface rotation, 17" vertical adjustment. Strong and stable with real wood worksurface and steel gas spring arm. Transition easily with one-handed adjustment (left or right handed). Keep essentials in reach with dual work surfaces and device viewing channel. Manage all cables with integrated cable channel. Mount to the back edge of any worksurface with adjustable clamp design. Manufacturer's five-year warranty. BIFMA Tested. 

ID No.	Colors	W × D × H	Shpg. Wt.	Unit	Price
<b>Single Monitor Workstations.</b>					
1	FEL-8081501	Black	35.5" × 23.75" × 42.2" to 49.2"	50 lbs.	Each <del>859.99</del>
2	FEL-8081701	White	35.5" × 23.75" × 42.2" to 49.2"	50 lbs.	Each <del>859.99</del>
<b>Dual Monitor Workstations.</b>					
3	FEL-8081601	Black	35.5" × 23.75" × 42.2" to 49.2"	50 lbs.	Each <del>879.99</del>
4	FEL-8081801	White	35.5" × 23.75" × 42.2" to 49.2"	50 lbs.	Each <del>879.99</del>

## C WORKFIT-A SIT-STAND WORKSTATION WITH WORKSURFACE+

Ideal for corner workstations, clamps to the rear or side of most surfaces and enables an effortless sit-and-stand work style. Fold the keyboard up and swing the arm out of the way when you need your desk surface. Change from a sitting to a standing position whenever you want. This height-adjustable workstation moves your keyboard and display in one simple motion, making computing comfortable for prolonged periods.

ID No.	Colors	Worksurface Dimensions	Total Weight Capacity	Shpg. Wt.	Unit	Price
<b>Dual LCD Monitors</b> —Holds two LCD monitors up to 24" each.						
6	ERG-24316026	Polished Aluminum/Black	9 3/4" × 22 3/4"	25 lbs.	51 lbs. Each	<del>985.00</del>

## D WORKFIT-A SIT-STAND WORKSTATION WITH SUSPENDED KEYBOARD

This premium stand-up desk solution adds extra ergonomic benefits, allowing the keyboard tray to be positioned below desktop level for optimum comfort. Fold your keyboard up and swing the arm out of the way when you need your desk surface. Included worksurface provides ample space and quick access to a tablet computer, phone or task-related items. VESA MIS-D Compliant.

ID No.	Colors	W × D × H	Shpg. Wt.	Unit	Price
<b>Single LCD.</b>					
7	ERG-24390026	Polished Aluminum/Black	21 1/2" × 11" × 17" to 37"	45 lbs.	Each <del>930.00</del>
<b>Dual LCD.</b>					
8	ERG-24392026	Polished Aluminum/Black	21 1/2" × 11" × 17" to 37"	49 lbs.	Each <del>1,020.00</del>

**WORKFIT™**  
by ergotron

## WorkFit Sit-Stand Workstations

Enjoy standing or sitting as you work, switching positions whenever you choose.

- Patented Constant Force™ lift technology.
- Modify existing office spaces or cubes by simply clamping it on an existing worksurface edge.
- Manufacturer's five-year warranty. 

## B WORKFIT-A SIT-STAND WORKSTATION

This workstation enables you to move your keyboard and display in one simple motion, making computing comfortable for prolonged periods. It also can accommodate the heights of multiple users who may use a single workstation. Fold the keyboard up and swing the arm out of the way when you need your desk surface.

ID No.	Colors	W × D × H	Shpg. Wt.	Unit	Price
<b>Dual LCD Monitors.</b>					
5	ERG-24312026	Polished Aluminum/Black	21 1/2" × 11" × 17" to 37"	48 lbs.	Each <del>825.00</del>



**Great Service**

We can help you with selection & solutions.



ergotron

**A ERGOTRON® LX DUAL DIRECT MONITOR ARM**

Easily move two monitors simultaneously to the best ergonomic position. Allows you to work comfortably and helps reduce eye, back and neck strain. Frees up your desktop to increase valuable workspace. Offers an easy-to-use experience — simple installation to effortless operation. Provides easy display adjustment with patented Constant Force™ technology. Passes Ergotron's 10,000-cycle motion test ensuring years of trouble-free height adjustment. 10-year warranty.

ID No.	For Monitors (Size, Weight)	Weight	Unit	Price
1 ERG-45489224	Up to 25", up to 11 lbs each	15.5 lbs	Each	<del>525.00</del>
2 ERG-45489026	Up to 25", up to 11 lbs each	15.5 lbs	Each	<del>525.00</del>

VESA MIS-D Compliant.

**B THIN CLIENT MOUNT**

Creates a complete workstation by adding a small computer to a display mount. Includes hardware for multiple attachment options to surfaces and Ergotron mounts. Size-adjustable holder fits a wide range of small computers, including all generations of the Apple® Mac mini. Saves space with a universal VESA interface that attaches to any VESA mount with a 3.94" (10 cm) or 2.96" (7.5 cm) hole pattern. Steel construction. Includes a 5-year warranty.

ID No.	For Monitors (Size, Weight)	Weight	Unit	Price
3 ERG-80107200	Up to 6 lbs.	2 lbs.	Each	<del>95.00</del>

VESA MIS-D Compliant.

**C LX DUAL SIDE-BY-SIDE ARM**

This dual side-by-side arm easily accommodates two LCD screens, perfectly aligning them on a sleek, streamlined base. Create a fully adjustable side-by-side configuration, lifting both screens up to where they're easier to see, freeing valuable workspace. Provides unparalleled range of motion using Constant Force patented lift-and-pivot motion technology. Features height adjustment, extension/retraction motion and tilt of LCDs as workflow requires with an integrated landscape-to-portrait mode for one or both LCDs. Manufacturer's ten-year warranty.

ID No.	Colors	W x D x H	Shpg. Wt.	Unit	Price
4 ERG-45245026	Polished Aluminum/Black	21½" x 25¾" x 10½" to 20¾"	18 lbs.	Each	<del>720.00</del>

**D LX SERIES LCD ARM**

LCD arm is the perfect accessory to add flexibility and superior ergonomics to your LCD monitor or TV. Sleek and streamlined, it frees up space and allows you to easily position your display for greater productivity. Ideal for home and office use, especially in situations where several people use the same display. Constant Force™ patented lift-and-pivot motion technology allows you to easily lift, swing, tilt or turn your display with a light touch of your hand. Manufacturer's ten-year warranty.

ID No.	Colors	W x D x H	Shpg. Wt.	Unit	Price
5 ERG-45241026	Polished Aluminum/Black	11¼" x 7¼" x to 25½"	10 lbs.	Each	<del>370.00</del>

**Desk Mount**—Desk clamp attaches to surface edge up to 2.4" thick. Grommet mount attaches through surface holes .31" to 2" wide and up to 3" thick.

20-MF-L-FCL



## ITS FATHER WAS AN OFFICE CHAIR. ITS MOTHER WAS AN EXERCISE BALL.

Part chair. Part ball. All fun. The Zenergy™ Ball Chair offers more than a comfy place to sit. It can improve your posture and balance, increase productivity and focus, and strengthen your core muscles—six pack, anyone? Bet your regular desk chair can't do that. The road to office happiness begins at **Safco**.

Design by Thomas Walser



Zenergy™ Ball Chair

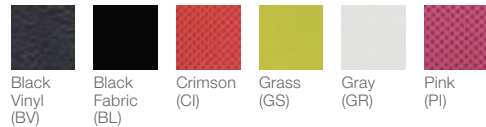

### Zenergy™ Ball Chair Series

Provides an active seating experience that may potentially increase concentration and retention.

- May help promote better posture and balance through building core muscle strength.
- Perfect for use in a variety of applications including collaboration spaces, lobby areas, meeting rooms and personal workspaces.
- Anti-burst exercise ball.
- Pump included.
- Manufacturer's limited lifetime warranty.
- GREENGUARD Certified.



ID No.	Color	Shpg. Wt.	Unit	Price
<b>A BALL CHAIR</b>				
Supports up to 250 lbs. Overall height: 23".				
<b>Vinyl</b>				
1	SAF-4751BV	Black	15 lbs.	Each 267.00
<b>Fabric</b>				
2	SAF-4750BL	Black	15 lbs.	Each 267.00
3	SAF-4750CI	Crimson	15 lbs.	Each 267.00
4	SAF-4750GS	Grass	15 lbs.	Each 267.00
5	SAF-4750GR	Gray	15 lbs.	Each 267.00
6	SAF-4750PI	Pink	15 lbs.	Each 267.00

\* Chairs are not intended for use during exercise. Not recommended for use as a full-time task chair and should not be the only seating option.

### Swivel Keg Seating

A new spin on traditional, stationary keg seating.

- Adds 360-degree swivel functionality, inviting a more active seating solution in the office, in break rooms or in gathering areas.
- When used, it may improve posture and balance by responding to user-controlled movement, allowing users to safely engage muscles throughout the workday.
- Features a durable, silver powder coated steel base, in which the swivel mechanism is hidden.
- Manufacturer's limited lifetime warranty.

ID No.	Color	Shpg. Wt.	Unit	Price
<b>B SWIVEL KEG SEATING</b>				
Supports up to 250 lbs. Overall height: 20".				
7	SAF-5050BL	Black	25 lbs.	Each 251.00



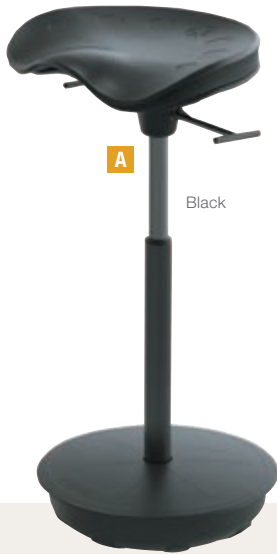

A

Black



B

Black

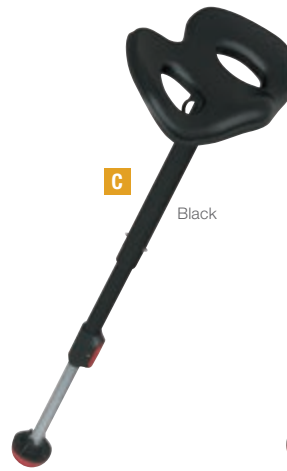

C

Black



C

Red

Pivot & Mogo II Seat Series

In Stock



Black (BK)

Special Order



Blue (BL)



Citrus (CT)



Red (RD)

**\*IMPORTANT:** When ordering special order items, add the finish code to the model number. Codes vary in length and placement. Example: ABC-12345**AB**



Requires additional lead time and cannot be returned.

## Mobis II Seat Series

Tri-flex seat cushion has built-in sitz bone contours for plush support and a waterfall edge that may help reduce pressure on the upper legs.

- Pivoting seat leg encourages dynamic movement to keep users active throughout the workday.
- Easy-adjust handles to lift and lower the seat.
- Seat pan is positioned forward which may help promote the optimal open hip angle compared to sitting; this angle potentially helps to engage the core muscles and enable posture perfection.
- Ellipse-shaped base with non-slip rim provides stability for active postures.
- Manufacturer's limited lifetime warranty.

ID No.	Color	Shpg. Wt.	Unit	Price
<b>B MOBIS II SEAT BY FOCAL UPRIGHT™</b>				
Supports up to 300 lbs. Seat: 12" x 16". Overall height: 25" to 35". <sup>①</sup>				
3	SAF-FFS2000BK	Black	32 lbs.	Each <del>640.00</del>
4	SAF-FFS2000_	Special Order	32 lbs.	Each <del>640.00</del>



## Pivot Seat Series

The weighted base leverages your center of gravity to support various degrees of use.

- Rubber octogrip overmold grips on bottom of base and enables you to enjoy a full range of motion while maintaining control.
- Pivoting seat leg empowers you to move 360 degrees.
- Seat pan is positioned forward which may help promote the optimal open hip angle compared to sitting; this angle potentially helps to engage the core muscles and enable posture perfection.
- Supports leaning posture – that may encourage a hip-to-torso range of 130 to 135 degrees which may allow for the least amount of pressure on your spine and connecting muscles.
- Easy-adjust piston-release handles raise and lower the seat, encouraging a range of postures from active sitting to leaning.
- Tri-flex seat cushion has built-in sitz bone contours for plush support and a waterfall edge that may help reduce pressure on the upper legs.
- Works with any standing desk/table and is rated up to 300 lbs.
- Accommodates user heights between 4'11" and 6'8".
- Manufacturer's limited lifetime warranty.

ID No.	Color	Shpg. Wt.	Unit	Price
<b>A PIVOT SEAT BY FOCAL UPRIGHT™</b>				
Supports up to 300 lbs. Seat: 12" x 16". Overall height: 26" to 35½".				
1	SAF-FWS1000BK	Black	33 lbs.	Each <del>450.00</del>
2	SAF-FWS1000_	Special Order	33 lbs.	Each <del>450.00</del>

## Mogo Seat Series

Non-slip, easy-to-clean seat cushion may help to reduce pressure points throughout the day.

- Supports leaning posture that may encourage a hip-to-torso range of 130 to 135 degrees, which may allow for the least amount of pressure on your spine and connecting muscles.
- Soft, durometer rubber foot works on non-slip, indoor surfaces.
- Reinforced-fiberglass turf tip keeps you stabilized on grass, dirt and turf.
- Collapsible, compact and portable design for use anywhere a seat might be needed.
- Pivoting seat leg has a wide range of motion, encouraging dynamic movement.
- Multiple notches for easy height adjustments; accommodates user heights between 4'11" and 6'8".
- Works with any standing desk/table and is rated up to 300 lbs.
- Manufacturer's limited lifetime warranty.

ID No.	Color	Shpg. Wt.	Unit	Price
<b>C MOGO SEAT BY FOCAL UPRIGHT™</b>				
Supports up to 300 lbs. Seat: 7½" x 1½". Overall height: 18½" to 38". <sup>①</sup>				
5	SAF-FKS1000BK	Black	4 lbs.	Each <del>142.00</del>
6	SAF-FKS1000RD	Red	4 lbs.	Each <del>142.00</del>



<sup>①</sup> For more information on additional chair features see page 80.

Pneumatic Seat Height Adjustment

# Sit To Stand Stools

A



Black

Perch Series



Black

B



Black Fabric (BL)



Blue (BU)



Orange (OR)

Twixt™ Series



Black Vinyl (BV)



Black Fabric (BL)



Blue (BU)



Green (GN)



Orange (OR)



Green (GN)

C



Black Vinyl (BV)

HON.

## Perch Series

Forward tilt design promotes a forward posture and open hip angle

- Seat moves 360-degrees and returns to a center-facing position.
- Waterfall seat edge improves lower body circulation, balance and strength.
- Flared handle design matches the curvature of the seat and provides a confident grip.
- One-touch height adjustment quickly and easily changes seat height.
- Seat contours align with the body's natural curves to provide active support while perching.
- Backed by the HON Limited Five-year Warranty.

ID No.	Color	Shpg. Wt.	Unit	Price
<b>A PERCH SERIES</b>				
Supports up to 250 lbs. Seat: 15" x 16". Overall height: 24" to 36".				
1	BSX-VLPERCHAS10X	Black	34 lbs.	Each <del>494.00</del>

For more information on additional chair features see page 80.



Pneumatic Seat Height Adjustment

SAFCO

## Twixt™ Series

Designed to help support better posture and balance

- Flexible ring under base allows user to adjust angle for sitting and providing movement for continuous comfort.
- Upholstered seat, height-adjustable and 360° swivel.
- Black base and cylinder.
- Manufacturer's limited lifetime warranty.

ID No.	Color	Shpg. Wt.	Unit	Price
<b>B DESK HEIGHT ERGONOMIC STOOL</b>				
Supports up to 250 lbs. Overall height: 17" to 22".				
<b>Vinyl</b>				
2	SAF-3000BV	Black Vinyl	16 lbs.	Each <del>256.00</del>
<b>Fabric</b>				
3	SAF-3000BL	Black	16 lbs.	Each <del>256.00</del>
4	SAF-3000BU	Blue	16 lbs.	Each <del>256.00</del>
5	SAF-3000GN	Green	16 lbs.	Each <del>256.00</del>
6	SAF-3000OR	Orange	16 lbs.	Each <del>256.00</del>
<b>C EXTENDED-HEIGHT ERGONOMIC CHAIR</b>				
Supports up to 250 lbs. Seat: 14½" x 14½". Overall height: 22" to 31¾".				
<b>Vinyl</b>				
7	SAF-3001BV	Black Vinyl	17 lbs.	Each <del>201.00</del>
<b>Fabric</b>				
8	SAF-3001BL	Black	17 lbs.	Each <del>201.00</del>
9	SAF-3001BU	Blue	17 lbs.	Each <del>201.00</del>
10	SAF-3001GN	Green	17 lbs.	Each <del>201.00</del>
11	SAF-3001OR	Orange	17 lbs.	Each <del>201.00</del>



## Alera® Perch Series

Advanced active ergonomics goes from sitting to standing with ease.

- Pivoting angled column moves with the body for constant alignment.
- Great for perching for fast tasks or lean back and sit for more intensive focused work.
- Goes from sitting height to standing height; perfect for use with height adjustable workstations.
- Auto return swivel seat moves with the body as you twist, and returns to front automatically when you get up.
- Dual integrated height adjustment levers for quick adjustments with either hand.
- Wide boomerang base for stability when leaning far forward.
- Manufacturer's limited five-year warranty.
- Meets or exceeds ANSI/BIFMA Standards.

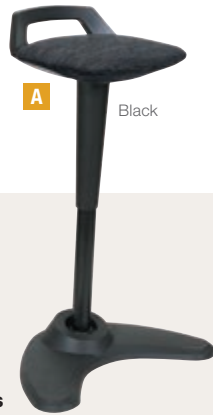

**A** Black



**B** Black

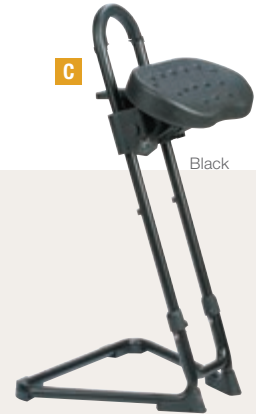

**C** Black

ID No.	Seat/Back Color	Base Color	Shpg. Wt.	Unit	Price
--------	-----------------	------------	-----------	------	-------

**A SIT TO STAND PERCH STOOL**

Supports up to 250 lbs. Seat: 14¼" × 13¾". Overall height: 25½" to 36½". <sup>①</sup>

1	ALE-AE35PSBK	Black	Black	20 lbs.	Each	<del>375.00</del>
---	--------------	-------	-------	---------	------	-------------------

## Perch Sit Stool Series

Comfortable, stylish and adjustable.

- Ideal for general office, task, interactive and collaborative environments.
- Plush comfortable seat with tilt feature allows user to perch in a dynamic work position.
- Seat height range suitable for adjustable workbench, desk and counter applications.
- Ready to reach handles for hassle free adjustment.
- Built in handle for portability.
- Round steel base provides reliable and firm support.
- Manufacturer's limited five-year warranty.
- Meets or exceeds ANSI/BIFMA Standards.

ID No.	Seat/Back Color	Base Color	Shpg. Wt.	Unit	Price
--------	-----------------	------------	-----------	------	-------

**B PERCH SIT STOOL**

Supports up to 250 lbs. Seat: 14" × 14". Overall height: 25¼" to 35½". <sup>①</sup> <sup>⑧</sup> <sup>⑪</sup>

2	ALE-SQ600	Black	Black	22 lbs.	Each	<del>309.00</del>
---	-----------	-------	-------	---------	------	-------------------

## SS Series

Designed to deliver the comfort of sitting even when standing.

- Perfect for front office, reception, back office, workbench, service desk, production floor, tradeshow and many commercial environments.
- Ergonomic seat is height adjustable for desk or counter heights; and pivots from flat to angled for a sit or leaning positioning.
- Solid wide support steel won't tip even when leaning far forward.
- Tear/poke resistant and wipe-friendly seat facilitates easy maintenance.
- Non-marring rubber padded base assures stability.
- Manufacturer's limited five-year warranty.
- Meets or exceeds ANSI/BIFMA Standards.

ID No.	Seat/Back Color	Base Color	Shpg. Wt.	Unit	Price
--------	-----------------	------------	-----------	------	-------

**C SIT/STAND ADJUSTABLE STOOL**

Supports up to 300 lbs. Seat: 14" × 8½". Overall height: 35½".

3	ALE-SS600	Black	Black	26 lbs.	Each	<del>372.66</del>
---	-----------	-------	-------	---------	------	-------------------

## Locus™ Leaning Seat Series

In Stock



Black (BK)

Special Order



Citrus (CT)



Nubuck (NB)



Red (RD)



Requires additional lead time and cannot be returned.

**\*IMPORTANT:** When ordering special order items, add the finish code to the model number. Codes vary in length and placement. Example: ABC-12345**AB**

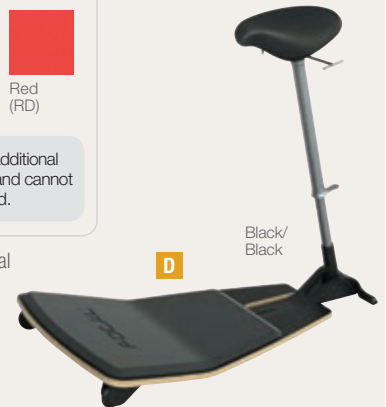

**D** Black/Black



## Locus™ Leaning Seat Series

Non-slip, easy-to-clean seat cushion may help to reduce pressure points throughout the day.

- Pivoting seat leg encourages dynamic movement.
- Seat pan tilts with knob up to 5 degrees to potentially help support hip flexibility.
- Designed to adjust to body's movements; these movements may help the body to be more active, relax the spine and engage muscles.
- Accommodates heights between 4'11" and 6'8".
- Discreetly designed wheels for easy portability.
- Post folds for easy storage.
- Anti-fatigue mat, included, may help to relieve stress on your feet and lower body while leaning/perching; use is optional.
- Works with any standing desk/table and is rated up to 300 lbs.
- Manufacturer's limited lifetime warranty.

ID No.	Color	Shpg. Wt.	Unit	Price
--------	-------	-----------	------	-------

**D LOCUS™ LEANING SEAT BY FOCAL UPRIGHT™**

Supports up to 300 lbs. Seat: 10" × 15". Overall height: 25½". <sup>①</sup>

4	SAF-FLT1000BKBK	Black/Black	48 lbs.	Each	<del>1,117.00</del>
5	SAF-FLT1000BK_	Black/_	48 lbs.	Each	<del>1,117.00</del>



Pneumatic Seat Height Adjustment



Posture Lock



Dual-Clutch Posture Control

For more information on additional chair features see page 80.

# Sit to Stand Accessories

## FLOORTEX<sup>®</sup> INTRODUCES AFS-TEX<sup>™</sup> ANTI-FATIGUE ERGONOMIC SOLUTIONS

Ergonomic Anti-Fatigue solutions combine standing comfort & body support with movement stimulating features for maximum performance.



**A AFS-TEX 5000X ANTI-FATIGUE MAT**

Contoured non-linear profile of between 0.8" and 2" stimulates regular movement and changes in standing positions. Raised ergonomic surround and ergobar features facilitate rocking or stretching of the feet and ankles that can stimulate blood flow and increase the body's metabolism. Surface massage pods also help to stimulate the feet and further reduce fatigue. Fine polyester cover for added tactile comfort and durability. An active anti-microbial ingredient protects the product from microbial deterioration. Manufacturer's limited 10-year warranty.

ID No.	Color	W x L	Qty.	Unit	Price	
1	FLR-FCA5XBK2535	Black	26" x 36"	1	Each	<del>149.99</del>



**B AFS-TEX 4000 ANTI-FATIGUE MAT**

Contoured non-linear profile of between 0.8" and 2" stimulate sub-conscious movement. Raised ergonomic surround features and ergobar facilitate further rocking or stretching of feet and ankles to stimulate blood flow and increase the body's metabolism. Surface massage pods also help to stimulate the feet and further reduce fatigue. A fine anti-microbial polyester cover provides added tactile comfort. Reduced footprint ideal use in compact work space. Anti-slip base. Manufacturer's limited 10-year warranty.

ID No.	Color	W x L	Qty.	Unit	Price	
5	FLR-FCA42030XBK	Black	20" x 30"	1	Each	<del>199.99</del>



**C AFS-TEX 3000 ANTI-FATIGUE MAT**

Extra deep (20mm) polyurethane construction provides a cushioned yet supportive standing surface. Reduces the strain on feet, legs knees and back joints caused through prolonged standing. Fine anti-microbial polyester cover for added comfort and warmth. Anti-slip base. Manufacturer's limited 10-year warranty.

ID No.	Color	W x L	Qty.	Unit	Price	
2	FLR-FCA32039BM	Black	20" x 39"	1	Each	<del>99.99</del>



**D AFS-TEX 3000X ANTI-FATIGUE MAT**

Extra deep (20mm) polyurethane construction provides a cushioned yet supportive standing surface. Reduces the strain on feet, legs, knees and back joints caused by prolonged standing. Fine anti-microbial polyester cover for added tactile comfort and durability. Massaging debossed surface features for added fatigue relief. Anti-slip base. Manufacturer's limited 10-year warranty.

ID No.	Color	W x L	Qty.	Unit	Price	
6	FLR-FCA32039XBM	Black	20" x 39"	1	Each	<del>199.99</del>



**E AFS-TEX 2000 ANTI-FATIGUE MAT**

Ergonomically designed print style to encourage regular foot movement to help stimulate blood flow and increase the body's metabolism. Contains an active anti-microbial ingredient to protect the product from microbial deterioration. Manufacturer's limited 10-year warranty.

ID No.	Color	W x L	Qty.	Unit	Price	
3	FLR-FCA21624BK	Midnight Black	16" x 24"	1	Each	<del>59.99</del>
4	FLR-FCA22032BK	Black	20" x 32"	1	Each	<del>79.99</del>



**F AFS-TEX 2000X ANTI-FATIGUE MAT**

Advanced standing surface includes foot massage contoured features. Encourages regular foot movement and changes in standing position to help stimulate blood flow and increase the body's metabolism. Cut out section provides a 90° ankle flex facility for added movement and strain relief. Fine anti-microbial polyester covering for added comfort and warmth. Anti-slip base. Manufacturer's limited 10-year warranty.

ID No.	Color	W x L	Qty.	Unit	Price	
7	FLR-FCA21624XBK	Black	16" x 24"	1	Each	<del>64.99</del>
8	FLR-FCA22032XBK	Black	20" x 32"	1	Each	<del>87.49</del>



**G AFS-TEX DYNAMIC FOOT REST**

This active footrest prompts lower body activity when sitting to stimulate blood flow and reduce fatigue. A design based on research into the benefits of fidgeting, the Dynamic footrest is designed to be difficult! It massages, rolls and wobbles underfoot so the user must keep it under control. This activity helps you make the most out of sitting at work. When not being moved, it can be used to elevate feet and rest the legs. Manufacturer's limited 10-year warranty.

ID No.	Color	W x D x H	Unit	Price	
9	FLR-FCDA0716BK	Black	16" x 7" x 7"	Each	<del>69.99</del>





**Fellowes**

**A ACTIVEFUSION™ ANTI-FATIGUE MAT**

Stay active and comfortable while enjoying the benefits of standing. Unique shape promotes stretching and movement throughout the day. The mat can be used with any sit-stand workstation for extra support while standing. Designed to encourage subtle movement and prevent fatigue. The beveled edges help avoid trip hazards. Manufacturer's limited five-year warranty.

ID No.	Color	Overall (W x L)	Qty.	Unit	Price
1 FEL-8707102	Black	36" x 24"	1	Each	<del>137.00</del>

**B ANTI-FATIGUE WELLNESS MAT**

Stand in comfort with this durable floor mat. Encourages subtle movement to prevent fatigue. Use with any sit-stand workstation for extra support while standing. Beveled edges help avoid trip hazards. Manufacturer's limited five-year warranty.

ID No.	Color	Overall (W x L)	Qty.	Unit	Price
2 FEL-8707002	Black	36" x 24"	1	Each	<del>74.00</del>

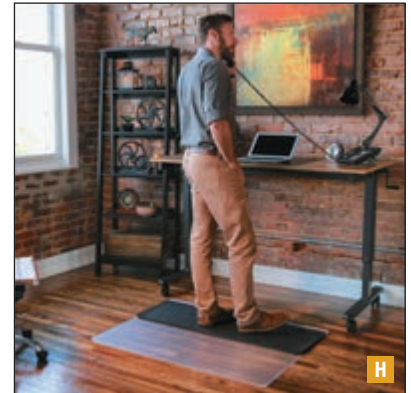

**deflecto®**

**C ERGONOMIC SIT STAND® MAT**

Dual-purpose cushioned mat combines the comfort and ergonomic benefit of an anti-fatigue mat with the smooth rolling surface of a traditional Deflecto office chair mat. Designed for use with standing desks and adjustable height workstations. For users looking to transition effortlessly from sitting to standing. With 3/8" thick anti-fatigue support foam, this mat is comfortable on the feet, promotes wellness and reduces fatigue while standing. It also protects flooring from wear and tear caused by wheeled office chairs. The black mat can also be used to cover worn, damaged or stained flooring. GREENGUARD Gold Certified for low chemical emissions and healthier indoor air. Free and Clear® non-orthophalate, non-cadmium formula promotes a healthy work environment without harsh chemicals. Manufacturer's Limited Lifetime Product Replacement Warranty. Patent pending.

ID No.	Color	W x L	Qty.	Unit	Price
3 DEF-CM24142BLKSS	Black	48" x 36"	1	Each	<del>219.00</del>
4 DEF-CM24242BLKSS	Black	53" x 45"	1	Each	<del>267.34</del>
5 DEF-CM24442BLKSS	Black	60" x 46"	1	Each	<del>280.78</del>

**ALERA.**

**F ADAPTIVERGO™ ANTI-FATIGUE MAT**

Encourages proper ergonomics and reduces fatigue with this cushioned standing mat. Beveled edge lays flat on the floor to reduce trip hazards. Rubber and vinyl construction ensures long lasting resiliency and cushioning. Ideal for use at sit-to-stand workstations, service counters, breakrooms, or wherever standing is required. Easy to clean surface with molded grid pattern to catch dirt and spills. Combine with Alera® AdaptiVergo™ Height Adjustable Tables or Alera® AdaptiVergo™ Lifting workstation for even more ergonomic benefits with your sit-to-stand workstations. Manufacturer's limited five-year warranty.

ID No.	Color	W x L	Qty.	Unit	Price
8 ALE-AE23AFM	Black	24" x 36"	1	Each	<del>99.00</del>

**WORKFIT™**  
by ergotron

**G ANTI-FATIGUE FLOOR MAT**

Durable mat is ergonomically designed to stimulate blood circulation and prevent fatigue by encouraging slight movement of lower legs. Highly flexible beveled edge reduces trip hazard. Specially-designed composite urethane technology with a skid-resistant backing; closed-cell construction for easy cleanup.

ID No.	Color	W x L	Qty.	Unit	Price
9 ERG-97620060	Black	24" x 36"	1	Each	<del>375.00</del>

**SAFCO**

**D ANTI-FATIGUE FLOOR MAT**

This thick, yet pliable floor mat ensures proper support with dense padding for comfort. It can be used with standing desks/workstations and service counters. Rounded corners and beveled edges help prevent tripping, and a textured area allows gripping with your foot to slide it out of the way without bending. Manufacturer's limited lifetime warranty.

ID No.	Color	W x L	Qty.	Unit	Price
6 SAF-2125BL	Black	29 1/4" x 27"	1	Each	<del>148.00</del>

**E ANTI-FATIGUE MAT**

This thick, yet pliable floor mat ensures proper support with 1" of dense padding for comfort. It can be used with standing desks/workstations and service counters. Rounded corners and beveled edges help prevent tripping, and a textured area allows gripping with your foot to slide it out of the way without bending. The underside of the mat features molded glides for mobility, but mat stays in place when in-use. Made from self-skinning polyurethane foam, the mat is lightweight, impact-resistant and wear-resistant. Manufacturer's limited lifetime warranty.

ID No.	Color	W x L	Qty.	Unit	Price
7 SAF-2110BL	Black	20" x 30"	1	Each	<del>81.00</del>

**E.S. ROBBINS**

**H SIT OR STAND MAT® FOR CARPET OR HARD FLOORS**

Unique dual purpose mat offers the flexibility to either sit or stand. Ideal for sit-to-stand desks. Roll with ease on the chair mat. Stand in comfort on supportive foam cushion. Protects wood floors, laminate, tile and other hard surfaces as well as carpets up to 3/8" thick including padding. Innovative hinge folds for cushion, unfolds for full size chairmat. Manufacturer's limited one-year warranty.

ID No.	Style	Overall (W x L)	Lip (W x L)	Unit	Price
10 ESR-184612	Lipped	36" x 53"	20" x 18"	Each	<del>150.00</del>
11 ESR-184603	Rectangular	45" x 53"	No Lip	Each	<del>199.00</del>

Prices subject to change without notice.  
Visit our website for the latest pricing and product information.

# Sit To Stand Accessories



## A BALANCE BOARD

Balance board designed to encourage a more active workday. Manufacturer's limited lifetime warranty.

ID No.	W x D x H	Color	Unit	Price
1 SAF-2128BL	32¼" x 12¼" x 3"	Black	Each	<del>161.00</del>

## B DYNAMIC FOOTREST

Made of durable steel with powder coat finish, the footrest allows movement throughout the day and encourages varying postures while working. Swing bar allows user to easily stay active by moving the footrest bar while standing at a height-adjustable or standing desk. Pairs well with either sitting or standing workstations. Bar moves silently to avoid workplace distraction. Manufacturer's limited lifetime warranty.

ID No.	W x D x H	Color	Unit	Price
2 SAF-2134BL	29" x 17¾" x 16½"	Black	Each	<del>179.00</del>

## C STABILIZING FOOTREST BY FOCAL UPRIGHT™

Helps to take pressure off of your foot bones. It also allows you to keep moving by encouraging you to vary your posture throughout the workday. Can be paired with standing desks or tables, and traditional seated workstations. Can also be paired with other Safco Active Seating products. Features a non-slip design that keeps the footrest in place on hard and soft surfaces. Lightweight for easy portability, and has non-marring butyl rubber to keep from slipping. Made with a sturdy, extruded aluminum bar. Designed by Martin Keen. Manufacturer's limited lifetime warranty.

ID No.	W x D x H	Color	Unit	Price
3 SAF-FFR1000	14" x 26" x 3½"	Aluminum/Black	Each	<del>97.00</del>

## D HEIGHT-ADJUSTABLE FOOTREST

Provides an ergonomic solution for your feet and back while sitting or standing. Constructed of steel and aluminum with a nylon platform for durability, and raised bumps on the platform for added foot grip. Clean, industrial appearance is great for any desk or table, as well as backroom and warehouse use. The footrest can also be paired with a standing workstation for added ergonomic support. Infinitely adjustable with cam-lock to set at desired height for user comfort, from 3½ inches to 16 inches. Manufacturer's limited lifetime warranty.

ID No.	W x D x H	Color	Unit	Price
4 SAF-2129BL	20½" x 14½" x 3½" to 21½"	Black	Each	<del>167.00</del>

Footrest adjusts to nine different heights.



G

## E TASK MASTER® ADJUSTABLE FOOTREST

Fixed 8° angle helps relieve muscle strain. Adjusts to nine height positions with height range of 5½" to 15". Removable platform with textured anti-slip cover. Triangular steel base with black powder coated finish.

ID No.	W x D x H	Color	Unit	Price
5 SAF-5124	20" x 12" x 5½" to 15"	Black	Each	<del>220.00</del>

## F FOOT ROCKER FOOTREST

Unique footrest features an incremented rocking action to promote circulation and muscle stimulation by encouraging leg movement. Smaller footprint takes less floor space under desk. Manufacturer's limited lifetime warranty. GREENGUARD Certified.

ID No.	W x D x H	Color	Unit	Price
6 SAF-2122BL	17½" x 11½" x 3½"	Black	Each	<del>64.00</del>



## G STEPPIE MOTION BOARD

Perfect complement to a standing desk workstation, such as the Victor® High Rise™ Collection. This stylish yet unobtrusive motion board features a simple design that helps improve overall body wellness while you work. Designed with comfort in mind, the board gently rocks side-to-side while strengthening and stabilizing muscles in the core, lower back, hips, legs and ankles. Other health benefits include improved posture, increased circulation, and improved joint mobility. Manufacturer's three-year limited warranty.

ID No.	W x D x H	Color	Unit	Price
7 VCT-ST570	22½" x 14½" x 2½"	Two-Tone Gray	Each	<del>129.99</del>

## COMMIT TO BETTER HEALTH WITH AN ERGONOMIC CHAIR MAT

Ergonomic  
**Sit ♥ Stand®**  
**CHAIR MAT**



3/8" anti-fatigue  
support foam

Designed to promote  
workplace wellness.



Deflecto's ergonomic Sit Stand chair mat combines the smooth rolling surface of a traditional chair mat, with the cushion of an anti-fatigue standing mat to help relieve foot pressure.

It's the easiest way to transition from sitting to standing, and is the perfect complement for anyone looking to incorporate adjustable height workstations into their workplace wellness program.

- 3/8-inch thick anti-fatigue support foam provides cushion and resilience to reduce stress and strain while standing
- Provides durable, long-lasting protection from caster wear, spills and heavy traffic
- Smooth, easy-glide rolling surface allows chair wheels to move effortlessly
- Non-slip bottom surface reduces the need to reposition the chair mat
- Greenguard Gold Certified

Comfort. Durability. Protection.



# Computer Furniture

Bring technology, efficiency and comfort.



**Indispensable in today's tech-centered world**, these pieces offer the perfect solution to long hours working with a computer. Excellent ergonomics are the key and our sit-stand designs deliver, adapting to comfortable heights and encouraging healthy movement. From machine stands to workstations, our computer furniture offers flexibility, organization, even mobility, so you can work smarter in the digital age.

Workstations	59-63
Stands	64-66
Accessories	67



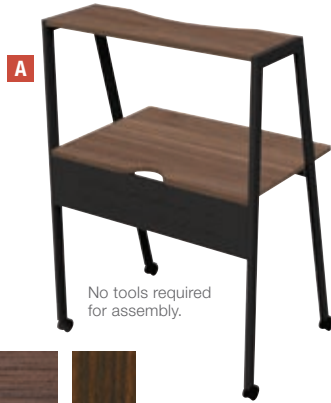

**A**

No tools required for assembly.



Mocha (MOC) Walnut (NW)



**B**

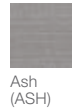

Ash (ASH)



**C**

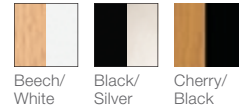

Beech/White Black/Silver Cherry/Black



**D**



**E**



Frosted/Black



**F**

**LI** linea italia<sup>®</sup>  
by CRISA

## A KOMPASS FLEXIBLE HOME/OFFICE DESK

Modern, minimalistic designs. Two-tier design complements contemporary, modern and traditional decors. Top shelf provides extra storage space. Casters for mobility. Ideal for home offices, dorms, lofts or wherever space is at a premium. Durable steel frame with metal modesty panel. Back notched for easy cable management. No tools required for assembly. Manufacturer's limited five-year warranty.  

ID No.	Color	W × D × H	Shpg. Wt.	Unit	Price	
1	LIT-SH764MOC	Mocha	33" × 23.4" × 48"	47 lbs.	Each	<del>259.00</del>
2	LIT-SH764NW	Walnut	33" × 23.4" × 48"	47 lbs.	Each	<del>259.00</del>

## B KLIN DESK

Open modern design is perfect for small spaces. Scratch- and stain-resistant woodgrain laminate top with grommet for wire management. Strong, silver powder-coated steel frame with modesty panel. Leveling glides adjust to accommodate uneven floors. Easy to assemble—no tools required. Manufacturer's limited five-year warranty. 

ID No.	Color	W × D × H	Shpg. Wt.	Unit	Price	
3	LIT-KLIN740ASH	Ash	33" × 19" × 29½"	31 lbs.	Each	<del>209.00</del>

**SAFCO**



## C STEEL DESK

Simple design and slim profile makes this desk a perfect fit for every workspace, no matter the existing decor. It's steel, u-shaped legs create smooth lines that will make you do a u-turn for another look. To expand on its intrigue, the workstation also features a wood top. With so much style, it's the perfect touch to help your work area have a little fun without sacrificing function. Manufacturer's limited lifetime warranty.

ID No.	Color	W × D × H	Shpg. Wt.	Unit	Price	
4	SAF-1943BHWH	Beech/White	47¼" × 24" × 28¾"	38 lbs.	Each	<del>303.00</del>
5	SAF-1943BLSL	Black/Silver	47¼" × 24" × 28¾"	38 lbs.	Each	<del>303.00</del>
6	SAF-1943CYBL	Cherry/Black	47¼" × 24" × 28¾"	38 lbs.	Each	<del>303.00</del>

## D - F XPRESSIONS™ COMPUTER DESKS

Tempered glass material accepts a dry erase marker so you can write down important numbers, notes and messages. Worksurface easily accommodates a laptop computer. Durable powder coated steel frame. Leveling glides help compensate for uneven flooring. Manufacturer's limited lifetime warranty. GREENGUARD Certified.  

## D 53¼" COMPUTER WORKSTATION

Attached side shelf gives you storage for books, binders or personal items. 

ID No.	Color	W × D × H	Shpg. Wt.	Unit	Price	
7	SAF-1936TG	Frosted/Black	53¼" × 23¼" × 45"	68 lbs.	Each	<del>557.00</del>

## E 47" COMPUTER WORKSTATION

Back panel is made from tempered glass, making it perfect for jotting important numbers or messages. 

ID No.	Color	W × D × H	Shpg. Wt.	Unit	Price	
8	SAF-1938TG	Frosted/Black	47" × 23" × 37"	73 lbs.	Each	<del>464.00</del>

## F KEYBOARD TRAY

Allows any user to save valuable desk space, while creating a desk that works perfectly for them! Pulls out with ease on glides. Durable construction for long-lasting use. Manufacturer's limited lifetime warranty.

ID No.	Color	Keyboard Tray Size	Unit	Price	
9	SAF-1940BL	Black	23½" × 15¼" × 2¼"	Each	<del>104.00</del>

Prices subject to change without notice.  
Visit our website for the latest pricing and product information.

# Computer Furniture Workstations



A



B

Cherry/  
Black



C

Cherry/  
Black  
(CY)

Cherry/  
Black



D

Cherry/  
Black

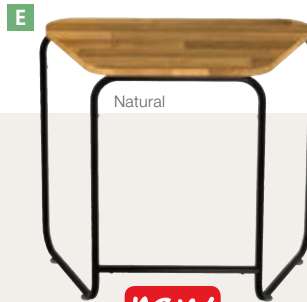

E

Natural

new



F

Medium  
Cherry



## A SCOOT™ STAND-UP DESK

Intriguing hole-pattern look provides a little personality to your workspace with a style that fits into any office ambiance. The workstation features a side pocket that is great for holding active files, projects or even your tablet when it's not in use. By using a stand-up workstation, users potentially can improve posture, burn calories and improve focus. The stand-up workstation is perfect for use in workspaces, classrooms and home use. Manufacturer's limited lifetime warranty.

ID No.	Colors	W x D x H	Shpg. Wt.	Unit	Price
1 SAF-1908BL	Black	39½" x 23¼" x 42"	47 lbs.	Each	<del>444.00</del>

## Muv™ Desks

Decorative molded side panels hide computer cables.

- Keyboard shelf extends 9¼" and retracts under the work surface.
- Durable powder coat steel frame.
- Cable management.
- Mobile on four casters (two locking).
- Assembly required.
- Manufacturer's lifetime warranty.

### B MUV™ DESKS

Features "step-less infinite adjustability" for increased personal comfort and productivity. Safety cap with cable management side covers. Includes tool for quick and easy assembly. Monitor and keyboard shelves adjust in 14" range, 35" to 49" high. Lower printer/CPU shelf adjusts in 1" increments. Fixed utility shelf.

ID No.	Colors	W x D x H	Shpg. Wt.	Unit	Price
2 SAF-1929CY	Cherry/Black	29½" x 22" x 35" to 49"	60 lbs.	Each	<del>399.00</del>
3 SAF-1929GR	Gray	29½" x 22" x 35" to 49"	60 lbs.	Each	<del>399.00</del>

### C MUV™ 28" ADJUSTABLE-HEIGHT DESK

Adjustable in 1" increments for increased personal comfort and productivity. Safety cap with cable management side covers. Includes tool for quick and easy assembly. Manufacturer's lifetime warranty.

ID No.	Colors	W x D x H	Shpg. Wt.	Unit	Price
4 SAF-1925CY	Cherry/Black	29½" x 22" x 29" to 34"	46 lbs.	Each	<del>546.00</del>

### D MUV™ 28" ADJUSTABLE-HEIGHT MINI-TOWER COMPUTER DESK

Adjustable in 1" increments for increased personal comfort and productivity. Safety cap with cable management side covers. Includes tool for quick and easy assembly. Manufacturer's lifetime warranty.

ID No.	Colors	W x D x H	Shpg. Wt.	Unit	Price
5 SAF-1927CY	Cherry/Black	35½" x 22" x 29" to 34"	62 lbs.	Each	<del>604.00</del>

### E SINGLE WORK TABLE

Create an individual workspace in collaboration areas. Long-lasting durability and a sleek aesthetic. Sled design, powder-coated base for durability. Butcher Block top supports up to 100 lbs. evenly distributed. Manufacturer's limited lifetime warranty.

ID No.	Color	Size	Shpg. Wt.	Unit	Price
6 SAF-5064NA	Natural	28¾" x 16" x 26"	16 lbs.	Each	<del>288.00</del>

### F LAPTOP COMPUTER CADDY

Split top tilts for ergonomic use and has raised paper stops to prevent items from slipping off.

ID No.	Color	W x D x H	Shpg. Wt.	Unit	Price
7 MLN-950ANT	Anthracite	29½" x 20" x 38"	19 lbs.	Each	<del>246.00</del>
8 MLN-950MEC	Medium Cherry	29½" x 20" x 38"	19 lbs.	Each	<del>246.00</del>

## Reversible Computer Desks



Mahogany/Black  
Medium Oak/Black



Mahogany



Mahogany



Cherry/Black



Cherry/Black



Cherry/Black



Cherry/Black

## Muv™ Series



Cherry/Black  
Gray



## Reversible Computer Desks

Melamine top reverses during set-up for a choice of mahogany or medium oak finish.

- Black steel base with full-width 6¾" deep storage shelf and 12" high privacy panel.
- Manufacturer's limited lifetime warranty.

### A COMPUTER DESK WITH REVERSIBLE TOP

Cable routing cutouts for installation along a wall.

ID No.	Color	W × D × H	Shpg. Wt.	Unit	Price
1	SAF-1931 Mahogany/Medium Oak/Black	47½" × 28" × 30"	70 lbs.	Each	<del>437.00</del>
2	SAF-1930 Mahogany/Medium Oak/Black	35½" × 28" × 30"	54 lbs.	Each	<del>399.00</del>

### B MOBILE COMPUTER DESK WITH REVERSIBLE TOP

Dual wheel casters (two locking) for easy mobility. Cable routing cutouts for installation along a wall.

ID No.	Color	W × D × H	Shpg. Wt.	Unit	Price
3	SAF-1933 Mahogany/Medium Oak/Black	53½" × 28" × 30"	75 lbs.	Each	<del>475.00</del>

### C MUV™ 28" ADJUSTABLE-HEIGHT DESK

Adjustable in 1" increments for increased personal comfort and productivity. Safety cap with cable management side covers. Includes tool for quick and easy assembly. Manufacturer's lifetime warranty.

ID No.	Colors	W × D × H	Shpg. Wt.	Unit	Price
4	SAF-1925CY Cherry/Black	29½" × 22" × 29" to 34"	46 lbs.	Each	<del>546.00</del>

### D MUV™ 28" ADJUSTABLE-HEIGHT MINI-TOWER COMPUTER DESK

Adjustable in 1" increments for increased personal comfort and productivity. Safety cap with cable management side covers. Includes tool for quick and easy assembly. Manufacturer's lifetime warranty.

ID No.	Colors	W × D × H	Shpg. Wt.	Unit	Price
5	SAF-1927CY Cherry/Black	35½" × 22" × 29" to 34"	62 lbs.	Each	<del>601.00</del>

### E MUV™ THREE LEVEL MACHINE CART/PRINTER STAND

Different heights accommodate different office needs. Durable powder-coated steel frame with ¾" thick adjustable melamine laminate shelves. PVC side panels hide cables for a clean front-office appearance. Perfect for deskside use. Manufacturer's limited lifetime warranty.

ID No.	Finish	W × D × H	Shpg. Wt.	Unit	Price
6	SAF-1881CY Cherry/Black	29½" × 20" × 35"	49 lbs.	Each	<del>399.00</del>

### F MUV™ STAND-UP ADJUSTABLE-HEIGHT DESK

Features "step-less infinite adjustability" for increased personal comfort and productivity. Safety cap with cable management side covers. Includes tool for quick and easy assembly. Monitor and keyboard shelves adjust in 14" range, 35" to 49" high. Lower printer/CPU shelf adjusts in 1" increments. Fixed utility shelf. Manufacturer's lifetime warranty.

ID No.	Colors	W × D × H	Shpg. Wt.	Unit	Price
7	SAF-1929CY Cherry/Black	29½" × 22" × 35" to 49"	60 lbs.	Each	<del>599.00</del>
8	SAF-1929GR Gray	29½" × 22" × 35" to 49"	60 lbs.	Each	<del>599.00</del>

Prices subject to change without notice.

Visit our website for the latest pricing and product information.

# Computer Furniture Workstations



**new**

**NO RETURN** Requires additional lead time and cannot be returned.



## Mood™ Standing Height Desk

Contemporary styling.

- Compact design—ideal for small or home offices.
- Manufacturer's limited lifetime warranty.
- Constructed of powder coated steel with a laminate finish for long-lasting durability.

### A STANDING HEIGHT DESK

Top portion can be mounted on right or left side during assembly. Unique design swings open to provide additional workspace as needed.

ID No.	Color	W × D × H	Shpg. Wt.	Unit	Price
1	SAF-1904GR	Gray	53¼" × 21¾" × 42¼"	90 lbs.	Each <del>365.00</del>

### B STANDING HEIGHT DESK

Features a thin profile and an open, steel frame. Add your choice of tall or extended-height seating to this desk for the option to sit or stand for different tasks (not included). Manufacturer's limited lifetime warranty. GREENGUARD Certified.

ID No.	Color	W × D × H	Shpg. Wt.	Unit	Price
<b>Cream Legs</b>					
2	SAF-1957BH	Beech	48" × 24" × 50"	61 lbs.	Each <del>346.00</del>
<b>Black Legs</b>					
3	SAF-1957WL	Walnut	48" × 24" × 50"	61 lbs.	Each <del>346.00</del>

## Xpressions™ Computer Desks

Tempered glass material accepts a dry erase marker so you can write down important numbers, notes and messages.

- Worksurface easily accommodates a laptop computer.
- Durable powder coated steel frame.
- Leveling glides help compensate for uneven flooring.
- Manufacturer's limited lifetime warranty.
- GREENGUARD Certified.

### C XPRESSIONS™ STAND-UP WORKSTATION

Back panel provides storage space for a notebook, mail, small books or project folders. Patented Swinging Pendulum™ Footrest Bar is designed to be noise-free and allows you to naturally fidget and move while standing at the desk.

ID No.	Colors	W × D × H	Shpg. Wt.	Unit	Price
4	SAF-1941TG	Frosted/Black	35" × 23" × 49"	62 lbs.	Each <del>594.00</del>

## AlphaBetter® Student Desks

Sitting stool with seat height adjustment.

- Welded steel frame is powder coated for durability and features a wide-angle, tip-resistant base design for student safety.
- 13"×13" seat constructed from 5/8" thick MDF with thermoplastic laminate finish which is chemical- and impact-resistant.
- Height adjustable in 1¼" increments (21½" to 35") to accommodate students of all ages and sizes.
- Metal swivel glide feet for easy movement across smooth and carpeted floors.
- Gives students the option of swinging their legs for continuous movement, which may facilitate better breathing and lumbar support with slouch-free, "open-angled" posturing.
- Stool can be used with the AlphaBetter® Desk Patented Swinging Pendulum™ Footrest Bar.
- GREENGUARD Certified.

### D ALPHABETTER® DESKS

This height-adjustable desk stands 26" to 42" high, and is designed for children grades 3-12. With a fire- and impact-resistant laminated desktop and durable steel frame, these desks provide comfort and convenience for every user. The standing desk offers natural movement via the Patented Swinging Pendulum™ Footrest Bar. Plus offers optimal shelf storage for school supplies and books. Manufacturer's limited lifetime warranty. GREENGUARD Certified.

ID No.	Color	W × D × H	Shpg. Wt.	Unit	Price
5	SAF-1201BE	Beige	28" × 20" × 42"	44 lbs.	Each <del>494.00</del>
<b>With Book Box</b>					
6	SAF-1202BE	Beige	28" × 20" × 42"	51 lbs.	Each <del>624.00</del>

### E ADJUSTABLE-HEIGHT STUDENT STOOL

Perfect substitute for standing. Stools adjust in 1¼" increments and allows students to sit and still use the patented Swinging Pendulum™ Footrest Bar (fidget bar). Supports up to 250 lbs. Seat: 15" × 15". Overall height: 21" to 35½".

ID No.	Seat/Back Color	Base Color	Shpg. Wt.	Unit	Price
7	SAF-1205BE	Beige/Black	Black	23 lbs.	Each <del>294.00</del>
8	SAF-1205BL	Black	Black	23 lbs.	Each <del>294.00</del>



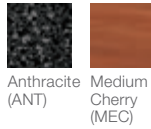

Medium Cherry (MEC)



Anthracite (ANT)



Black/Silver (BL)

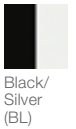

Light Gray/Medium Gray



Espresso (EB)

QAD Series Workstation



## A LAPTOP COMPUTER CADDY

Split top tilts for ergonomic use and has raised paper stops to prevent items from slipping off.

ID No.	Color	W x D x H	Shpg. Wt.	Unit	Price
1 MLN-950-ANT	Anthracite	29½" x 20" x 38"	19 lbs.	Each	<del>246.00</del>
2 MLN-950-MEC	Medium Cherry	29½" x 20" x 38"	19 lbs.	Each	<del>246.00</del>

## B EMPIRE MOBILE PC CART

Compact workstation offers plenty of space for computer equipment and supplies. Slide-out keyboard tray and perforated steel CPU shelf. Manufacturer's limited lifetime warranty.

ID No.	Finish	W x D x H	Shpg. Wt.	Unit	Price
3 MLN-945-ANT	Anthracite	29¾" x 23½" x 29¾"	41 lbs.	Each	<del>246.00</del>
4 MLN-945-MEC	Medium Cherry	29¾" x 23½" x 29¾"	41 lbs.	Each	<del>246.00</del>

## Xpressions™ Computer Desks

Tempered glass material accepts a dry erase marker so you can write down important numbers, notes and messages.

- Worksurface easily accommodates a laptop computer.
- Durable powder coated steel frame.
- Leveling glides help compensate for uneven flooring.
- Manufacturer's limited lifetime warranty.

## C SCOOT™ DESK

Find a style all your own with the unique and modern design of this sit-down workstation. Convenient side pocket holds active files, projects or tablet. Easily mobile on four swivel casters. Manufacturer's limited lifetime warranty.

ID No.	Color	W x D x H	Shpg. Wt.	Unit	Price
5 SAF-1907BL	Black/Silver	32¼" x 22" x 30½"	39 lbs.	Each	<del>303.00</del>

## D FOLDING COMPUTER TABLE

Folds to 5¼" deep for storage and mobility. Drop keyboard shelf with six height and tilt positions. ¾" laminate top on steel legs with black end caps. Holds CPU up to 19" deep. Manufacturer's limited lifetime warranty.

ID No.	Color	W x D x H	Shpg. Wt.	Unit	Price
6 SAF-1935GR	Light Gray/Medium Gray	47½" x 29¾" x 28¾"	41 lbs.	Each	<del>222.00</del>



## Alera® QAD Series

- Sized for the small office and anyplace where space is tight.
- Thermally-fused, scratch-, dent- and water-resistant laminate tops.
- Durable metal frames.
- Matching finishes throughout the QAD Series.
- Manufacturer's limited five-year warranty.
- Meets ANSI/BIFMA Standards.

## E QUICK ASSEMBLE COMPUTER WORKSTATION

ID No.	Color	W x D x H	Shpg. Wt.	Unit	Price
7 ALE-QAD4232EB	Espresso/Black	41¾" x 20¾" x 36¾"	38 lbs.	Each	<del>250.00</del>
8 ALE-QAD4232GS	Gray Oak/Silver	41¾" x 20¾" x 36¾"	38 lbs.	Each	<del>250.00</del>

# Computer Furniture Stands



Mahogany

Designed for oversized office equipment.



Black



Desk-Side

Black/Cherry



Underdesk

Black/Cherry

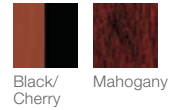

Black/Cherry

Mahogany



Black



Black



Black

Gray



## A MOBILE LAMINATE MACHINE STAND WITH OPEN COMPARTMENT

Double door cabinet, with contemporary black pulls, provides concealed storage. Stain- and scratch-resistant 3/4" laminate on furniture-grade wood construction. Four Casters, two locking. Designed for fax, printer or copier. Top rear of unit has 4" opening for cable routing. Storage shelf has grommet cut-out for cable routing into lower cabinet. Lower Storage Compartment: 26w x 17 1/4d x 14 1/4h; Upper Compartment: 26w x 17 1/4d x 9 1/4h.

ID No.	Finish	W x D x H	Shpg. Wt.	Unit	Price
1	SAF-1850MH *	Mahogany 28" x 19 1/4" x 30 1/2"	81 lbs.	Each	<del>521.00</del>

\* Contains 80% total recycled content.



## B - C IMPROMPTU™ MACHINE STANDS

Contemporary machine stand, featuring a steel, powder coat frame for durability and translucent polycarbonate panels, to complement any work environment. Generously sized laminate top accommodates most office machines. Four casters (two locking). Free up desk space and keeps additional printing supplies close at hand. Large storage area with one fixed shelf.

ID No.	Finish	W x D x H	Shpg. Wt.	Unit	Price
2	SAF-1857BL *	Black/Cherry 26 1/4" x 21" x 26 1/2"	41 lbs.	Each	<del>364.00</del>
3	SAF-1862BL *	Black/Cherry 20 1/2" x 16 1/2" x 14 1/2"	20 lbs.	Each	<del>243.00</del>

\* GREENGUARD Certified.

## D DELUXE STEEL MACHINE STAND

Designed for oversized office equipment. Double door cabinet with one fixed shelf for supplies. Black with laminate top and metallic gray legs. Manufacturer's limited lifetime warranty.

ID No.	Finish	W x D x H	Shpg. Wt.	Unit	Price
4	SAF-1872BL	Black 32" x 24 1/2" x 30 1/4"	63 lbs.	Each	<del>600.00</del>

## E DESK SIDE WIRE MACHINE STAND

The steel frame and a powder coat finish makes this machine stand a durable organization solution. Featuring two sturdy shelves to hold paper, supplies or snacks and is perfect for common work areas or meeting spaces. It's also mobile on four swivel casters, (2 locking). Stand holds up to 200 lbs. Manufacturer's limited lifetime warranty.

ID No.	Finish	W x D x H	Shpg. Wt.	Unit	Price
5	SAF-5207BL	Black 24" x 20" x 27"	33 lbs.	Each	<del>401.00</del>

## F UNDERDESK PRINTER/FAX STAND

Large surface provides ample space for most printers and fax machines. Sturdy steel wire shelf is ideal for storing extra paper or supplies. Low profile design allows storing under desk when not in use. Easy assembly, no tools required. Manufacturer's limited lifetime warranty.

ID No.	Finish	W x D x H	Shpg. Wt.	Unit	Price
6	SAF-5206BL	Black 19" x 16" x 13 1/2"	19 lbs.	Each	<del>126.00</del>
7	SAF-5206GR	Gray 19" x 16" x 13 1/2"	19 lbs.	Each	<del>126.00</del>



### A 3-IN-1 CART & STAND

Clever all-in-one design can be used as a utility cart, monitor stand, and/or printer cart. Includes 3 shelves, stacking columns, drawer and casters which can be configured any way you need such as a 2 or 3-tier cart and/or a single or double-shelf stand. Accommodates printers up to 75lbs. Manufacturer's limited five-year warranty.

ID No.	Finish	W x D x H	Shpg. Wt.	Unit	Price
1 ALE-U3N1BL	Black/Gray	21½" x 13¾" x 24¾"	14 lbs.	Each	<del>409.00</del>



### B - C SCOOT™ PRINTER STAND

Freestanding desk space and keeps additional printing supplies close at hand. Accommodates most desktop printers and other small office machines. Manufacturer's limited lifetime warranty.

ID No.	Finish	W x D x H	Shpg. Wt.	Unit	Price
--------	--------	-----------	-----------	------	-------

**B DESK SIDE STAND**—One height-adjustable shelf and an adjustable pocket for active files. Inner shelves hold up to 50 lbs. each; top supports up to 100 lbs.

2 SAF-1856BL	Black/Silver	26½" x 20½" x 26½"	45 lbs.	Each	<del>290.00</del>
--------------	--------------	--------------------	---------	------	-------------------

**C UNDERDESK STAND**—Hides printers and small office machines under most work surfaces.

3 SAF-1855BL	Black/Silver	20¼" x 16½" x 14½"	19 lbs.	Each	<del>147.00</del>
--------------	--------------	--------------------	---------	------	-------------------

### D ONYX UNDER DESK MACHINE STAND

Mobile cart on four swivel casters with two locking, slides easily under desk or work surface when not in use to save space.

ID No.	Finish	W x D x H	Shpg. Wt.	Unit	Price
--------	--------	-----------	-----------	------	-------

**2-Shelf Desk Machine Stand**—Wood laminate shelves with mesh baskets.

4 SAF-5208BL	Black	21" x 16" x 17½"	23 lbs.	Each	<del>212.00</del>
--------------	-------	------------------	---------	------	-------------------

5 SAF-5208WH	White	21" x 16" x 17½"	25 lbs.	Each	<del>212.00</del>
--------------	-------	------------------	---------	------	-------------------



### E - F WAVE DESIGN PRINTER STAND

Gray shelves accented with charcoal columns. Contemporary wave design shelves. Storage for paper, ink cartridges, envelopes and more. Easy to assemble. Manufacturer's limited lifetime warranty.

ID No.	Finish	W x D x H	Shpg. Wt.	Unit	Price
--------	--------	-----------	-----------	------	-------

**E DESK SIDE STAND**—Three shelves.

6 SAF-1860GR *	Charcoal Gray	20" x 17½" x 29¼"	18 lbs.	Each	<del>161.00</del>
----------------	---------------	-------------------	---------	------	-------------------

**F UNDERDESK STAND**—Two shelves. Tucks under most work surfaces to save valuable floor space.

7 SAF-1861GR *	Charcoal Gray	20" x 17½" x 11½"	11 lbs.	Each	<del>101.00</del>
----------------	---------------	-------------------	---------	------	-------------------

\* GREENGUARD Certified.

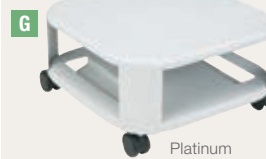

### G MOBILE PRINTER STAND

Stores printer under desk to save space. Accommodates most printers up to 18" x 18" and supports up to 75 lbs. Made of heavy-gauge, static dissipating steel. Two built-in power strip holders in the lower shelf for convenient AC access (power strips sold separately). Shelf dimensions: 17w x 17d.

ID No.	Finish	W x D x H	Shpg. Wt.	Unit	Price
--------	--------	-----------	-----------	------	-------

**Two-Shelf**

8 MAT-24050	Platinum	17½" x 17½" x 8½"	16 lbs.	Each	<del>147.10</del>
-------------	----------	-------------------	---------	------	-------------------



### H DESKSIDE MACHINE STAND

Durable steel and wire construction. Two shelves, one adjustable, help keep supplies close at hand.

ID No.	Finish	W x D x H	Shpg. Wt.	Unit	Price
--------	--------	-----------	-----------	------	-------

9 VRT-VF52004	Matte Gray	21½" x 17½" x 27"	28 lbs.	Each	<del>210.35</del>
---------------	------------	-------------------	---------	------	-------------------

### I UNDERDESK MACHINE STANDS

Durable steel and wire construction. Handy bottom shelf keeps supplies close at hand. Two surface grommets help route cords and cables; can also be used as a handle to pull stand from beneath worksurface.

ID No.	Finish	W x D x H	Shpg. Wt.	Unit	Price
--------	--------	-----------	-----------	------	-------

10 VRT-VF52009	Black	21½" x 17½" x 11½"	15 lbs.	Each	<del>120.33</del>
----------------	-------	--------------------	---------	------	-------------------

11 VRT-VF52005	Matte Gray	21½" x 17½" x 11½"	15 lbs.	Each	<del>120.33</del>
----------------	------------	--------------------	---------	------	-------------------

Prices subject to change without notice.

Visit our website for the latest pricing and product information.

# Computer Furniture Stands

VISIT US ONLINE FOR OUR FULL ASSORTMENT OF

Computer Furniture



Kompass Line



Mocha (MOC)



Walnut (NW)



B



C



D

Beige



E

Beige/Black



Alphabetter® Desk & Stool



Beige



Black



## Kompass Flexible Home/Office Desk

Modern, minimalistic designs.

- Ideal for home offices, dorms, lofts or wherever space is at a premium.
- Durable steel frame.
- No tools required for assembly. 📦 🛠️

### A KOMPASS FLEXIBLE HOME/OFFICE DESK

Two-tier design complements contemporary, modern and traditional decors. Top shelf provides extra storage space. Casters for mobility.

ID No.	Color	W × D × H	Shpg. Wt.	Unit	Price
1	LIT-SH764MOC	Mocha	33" × 23.4" × 48"	47 lbs.	Each <del>259.00</del>
2	LIT-SH764NW	Natural Walnut	33" × 23.75" × 48"	47 lbs.	Each <del>259.00</del>

## Study Carrells

Worksurface provides enough space for a flat screen monitor or a laptop.

- Cable grommet makes cord management simple.
- Features a long-lasting, superior design.
- Easy to assemble. 📦 🛠️

### B STUDY CARRELL

Create your own custom set up – just begin with a starter unit and attach as many add-on units (sold separately: Linea Italia® 802CH) as you need.

ID No.	Color	W × D × H	Shpg. Wt.	Unit	Price
<b>Starter Unit</b>					
3	LIT-SC801CH	Cherry	31¼" × 23½" × 45¼"	47 lbs.	Each <del>279.00</del>
<b>Add On</b>					
4	LIT-SC802CH	Cherry	31¼" × 23¼" × 45¼"	38 lbs.	Each <del>299.00</del>

### C STUDY CARRELL

Stand-alone unit features durable laminate construction throughout for a long, productive life.

ID No.	Color	W × D × H	Shpg. Wt.	Unit	Price
5	LIT-SC800MAP	Maple	23½" × 33" × 48½"	87 lbs.	Each <del>299.00</del>



## AlphaBetter® Student Desks & Stools

Welded steel frame is powder coated for durability.

- Desk Top and Stool Seat are constructed from ¾" thick MDF with Thermoplastic Laminate finish (chemical and impact-resistant).
- Manufacturer's limited lifetime warranty.
- GREENGUARD Certified. 📦 🛠️

### D ALPHABETTER® DESKS

Adjustable-height stand-up student desk with swinging footrest. Features patented Swinging Pendulum™ Footrest Bar (¾" diameter, 20" footrest area). Helps support ergonomic comfort and cardiovascular health. Phenolic resin open shelf (26"W × 8"D, ¼" thick) provides easily accessible storage area. Adjustable desktop height with fourteen settings ranging from 26" to 42¼" (1¼" increments).

ID No.	Color	W × D × H	Shpg. Wt.	Unit	Price
6	SAF-1201BE	Beige	28" × 20" × 42"	44 lbs.	Each <del>494.00</del>
<b>With Book Box</b>					
7	SAF-1202BE	Beige	28" × 20" × 42"	51 lbs.	Each <del>624.00</del>

### E ADJUSTABLE-HEIGHT STUDENT STOOL

Perfect substitute for standing. Stools adjust in 1¼" increments and allows students to sit and still use the patented Swinging Pendulum™ Footrest Bar (fidget bar). Supports up to 250 lbs. Seat: 13" × 13". Overall height: 21" to 35.5".

ID No.	Color	Shpg. Wt.	Unit	Price
8	SAF-1205BE	Beige/Black	23 lbs.	Each <del>294.00</del>
9	SAF-1205BL	Black	23 lbs.	Each <del>294.00</del>





### A MOBILE FILE CART

Keep paperwork handy when you need it and out of the way when you don't. Wheels glide with ease for mobility and lock for stability. Front-to-back and side-to-side filing. Accommodates letter or legal size hanging files. Four 2" dual-wheel hooded casters (2 locking). Manufacturer's limited five-year warranty. Meets or exceeds ANSI/BIFMA Standards.

ID No.	Finish	W x D x H	Shpg. Wt.	Unit	Price
1 ALE-FM642212G	Silver	22¼" x 12¾" x 25¼"	16 lbs.	Each	<del>109.00</del>



### B MOBILE STORAGE CART

Provides storage for printers, fax machines or other supplies. Powder-coated bent steel frame and melamine laminate top for long-lasting durability. Features a utility drawer, a storage bucket and coat hook for personal items. Five durable rubber casters for ease of mobility. Lower drawer fits standard or legal size hanging folders. Manufacturer's limited lifetime warranty.

ID No.	Finish	W x D x H	Shpg. Wt.	Unit	Price
2 SAF-5202WH	White	28" x 20" x 33½"	86 lbs.	Each	<del>660.00</del>

### C - D ONYX™ MESH MOBILE FILES

Durable, tubular steel mesh provides stylish yet practical organization. Black powder coat finish for durability. Easily fits under work surface when not needed. Four casters (two locking) for mobility. Collapsible drawers make assembly quick and easy. Manufacturer's limited lifetime warranty. GREENGUARD Certified.

### C ONYX™ MESH MOBILE FILE WITH FOUR SUPPLY DRAWERS

Mobile file with four letter-size storage drawers keep office essentials easily accessible and organized. Top shelf offers additional storage. Four 1½" casters (2 locking).

ID No.	Finish	W x D x H	Shpg. Wt.	Unit	Price
3 SAF-5214BL	Black	15¾" x 17" x 27"	23 lbs.	Each	<del>103.00</del>

### D ONYX™ MESH MOBILE FILE WITH TWO SUPPLY DRAWERS

Convenient letter-size file cube and two supply drawers slide easily on powder coated steel channels. Top shelf offers additional storage for supplies. Four 1½" casters (2 locking).

ID No.	Finish	W x D x H	Shpg. Wt.	Unit	Price
4 SAF-5213BL	Black	15¾" x 17" x 27"	21 lbs.	Each	<del>170.00</del>



### E - F MOBILE FILING CABINET

Mobile cabinet accommodates letter or legal-size files with built in rails. Each drawer locks individually. Built-in label holders. Manufacturer's 90-day warranty.

### E TWO-DRAWER MOBILE FILING CABINET

ID No.	Color	W x D x H	Shpg. Wt.	Unit	Price
5 STX-61314U01C	Black/Blue	14¾" x 18¼" x 26"	20 lbs.	Each	<del>171.55</del>
6 STX-61315U01C	Black/Teal	14¾" x 18¼" x 26"	20 lbs.	Each	<del>171.55</del>

### F SINGLE-DRAWER MOBILE FILING CABINET

Removable casters allow cabinet to be stacked on top of two-drawer mobile filing cabinet for added storage capacity.

ID No.	Color	W x D x H	Shpg. Wt.	Unit	Price
7 STX-61269U01C	Black/Blue	14¾" x 18¼" x 12¾"	9 lbs.	Each	<del>110.65</del>
8 STX-61270U01C	Black/Teal	14¾" x 18¼" x 12¾"	9 lbs.	Each	<del>100.65</del>

# Privacy Panels

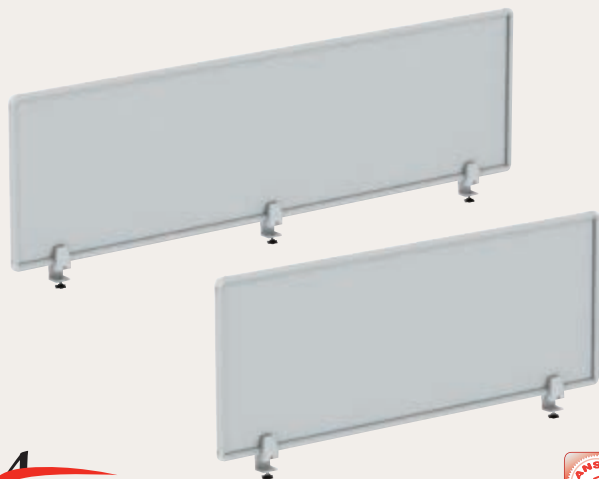

## Polycarbonate Privacy Panel

Semi-transparent frosted panel creates a private desk area while allowing light to filter through.

- Lightweight, waterproof and impact-resistant.
- Strong 1-7/8" wide metal brackets anchor panel securely to desktops up to 1" thick.
- Clip-on assembly with no tools required.
- Manufacturer's limited five-year warranty.
- Meets or Exceeds ANSI/BIFMA Standards.

Divides workspaces, but allows light to pass through. Secure clip-on attachment.

ID No.	W x D x H	Color	Shpg. Wt.	Unit	Price
1 ALE-PP4718 ★	47" x 1/2" x 18"	Silver/Clear	8 lbs.	Each	<del>490.00</del>
2 ALE-PP6518 ★	65" x 1/2" x 18"	Silver/Clear	9 lbs.	Each	<del>249.00</del>

★ Not freestanding.

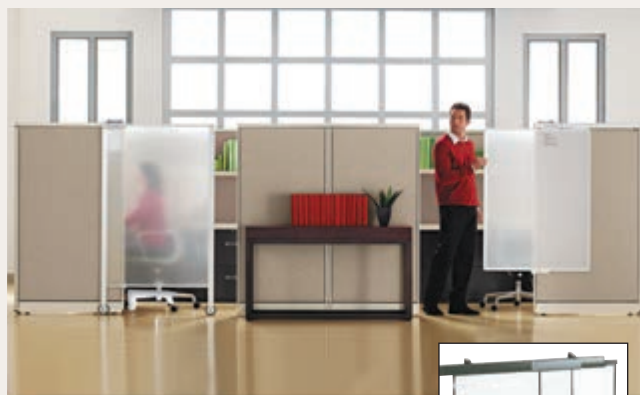

## Workstation Privacy Screen

Create a distraction-free environment with an ultra-lightweight, translucent barrier door that opens and closes for privacy.

- Secure to the outside of any cubicle panel 1-1/4" to 3-1/4" thick.
- Leave notes for coworkers or post special information on the dry erase message board with built-in marker tray.
- Includes nameplate to identify the cubicle user or department name.
- Brushed silver aluminum frame matches all decors.
- For panels under 65" high.

ID No.	W x D x H	Color	Shpg. Wt.	Unit	Price
4 QRT-WPS1000	36" x 1.25" x 48"	Translucent Clear/Silver	16 lbs.	Each	<del>344.19</del>



## Premium Workstation Privacy Screen

Ultra-lightweight, translucent plastic screen provides a barrier between you and unwanted distractions.

- Dry erase board comes complete with nameplate.
- H-frame design with two wheels keeps sliding door on track.
- Top and bottom mounting clamps install easily to cubicle and increase stability.
- Attach to standard 65" and higher cubicles.
- Includes 4" leg extenders to expand privacy for cubicles over 68" high.
- Installs on panels 1 1/4" to 3 1/4" wide.

ID No.	W x D x H	Color	Shpg. Wt.	Unit	Price
3 QRT-WPS2000	38" x 1.25" x 64"	Translucent Clear/Silver	21 lbs.	Each	<del>404.49</del>



## Impromptu® Whiteboard Collaboration Screen

Easily define any space with this magnetic whiteboard screen.

- Steel frame with four casters (two locking) for easy mobility.
- Magnetic accessory tray and easel pad hooks included.
- Manufacturer's limited lifetime warranty.
- GREENGUARD Certified.

ID No.	W x D x H	Color	Shpg. Wt.	Unit	Price
5 SAF-8511BL	42" x 21 1/2" x 72"	Black/White	60 lbs.	Each	<del>509.00</del>
6 SAF-8511GR	42" x 21 1/2" x 72"	Gray/White	60 lbs.	Each	<del>509.00</del>



### Straight Layout

Connect as many panels in a row as you need.

**A**



### Corner Layout

Connect panels in an L-shape to create more division. Connect up to two, three or four panels to a group.



Shown with HON Crio Mid-Back Chair, HON Perch Seating and HON Coordinate Height-Adjustable Tables.

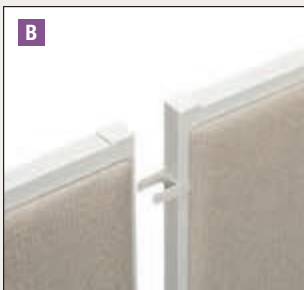

**B**

### 2 Panels 180°

Use one pair of Straight Connectors.



**B**

### Two Panels 90°

Use one pair of Corner Connectors.



**B**

### Three Panels

Use two pairs of Corner Connectors.



**B**

### Four Panels

Use three pairs of Corner Connectors



**B**

### Wall Bracket

Use a Wall Bracket to secure panels to walls.



**B**

### T-Base Foot

Use the T-Base to stabilize long runs of straight panels.



## Versé® Panels



Gray (GY)



Light Gray Frame

**Versé office partitions are a simple, yet effective way to divide space and provide privacy.**

- Design blends nicely with any desk.
- Variety of heights and widths can establish open sightlines or shield from distractions.
- With its quick and easy snap-on installation, Versé is excellent for temporary or short-term work environments.
- Backed by the HON Limited Five-Year Warranty.

### **A** VERSÉ® OFFICE PANEL

Panels can be freestanding with optional T-Base Foot (sold separately), or can be connected together to create walls, hallways and enclosed offices. Semi-tackable, gray fabric with matching powder coated steel frame. Adjustable glides with all panels.

ID No.	W x D x H	Color	Shpg. Wt.	Unit	Price	
1	24" x 1" x 42"	Gray	18 lbs.	Each	<del>301.00</del>	
2	BSX-P4230GYGY	30" x 1" x 42"	Gray	22 lbs.	Each	<del>311.00</del>
3	BSX-P4236GYGY	36" x 1" x 42"	Gray	24 lbs.	Each	<del>315.00</del>
4	BSX-P6024GYGY	24" x 1" x 60"	Gray	30 lbs.	Each	<del>335.00</del>
5	BSX-P4248GYGY	48" x 1" x 42"	Gray	34 lbs.	Each	<del>339.00</del>
6	BSX-P7224GYGY	24" x 1" x 72"	Gray	39 lbs.	Each	<del>376.00</del>
7	BSX-P4260GYGY	60" x 1" x 42"	Gray	36 lbs.	Each	<del>359.00</del>
8	BSX-P4272GYGY	72" x 1" x 42"	Gray	48 lbs.	Each	<del>410.00</del>
9	BSX-P6030GYGY	30" x 1" x 60"	Gray	33 lbs.	Each	<del>346.00</del>
10	BSX-P6036GYGY	36" x 1" x 60"	Gray	35 lbs.	Each	<del>347.00</del>
11	BSX-P7230GYGY	30" x 1" x 72"	Gray	40 lbs.	Each	<del>384.00</del>
12	BSX-P7236GYGY	36" x 1" x 72"	Gray	44 lbs.	Each	<del>404.00</del>
13	BSX-P6048GYGY	48" x 1" x 60"	Gray	42 lbs.	Each	<del>370.00</del>
14	BSX-P7248GYGY	48" x 1" x 72"	Gray	50 lbs.	Each	<del>432.00</del>
15	BSX-P6060GYGY	60" x 1" x 60"	Gray	54 lbs.	Each	<del>386.00</del>
16	BSX-P6072GYGY	72" x 1" x 60"	Gray	60 lbs.	Each	<del>452.00</del>
17	BSX-P7260GYGY	60" x 1" x 72"	Gray	62 lbs.	Each	<del>477.00</del>

### **B** VERSÉ® QUICK CONNECT CONNECTING HARDWARE

Connectors allow for easy installation. Simply snap on at the top & bottom of the panel and slide the panels together. 180° Straight Connectors connect two panels to create an extended wall. 90° Corner Connectors connect two panels to form a right angle corner.

ID No.	Description	Shpg. Wt.	Qty.	Unit	Price	
18	BSX-QC180GY	180° Straight Connector	1 lb.	2	Pair	<del>24.00</del>
19	BSX-QC90GY	90° Corner Connectors	1 lb.	2	Pair	<del>24.00</del>
20	BSX-PWB1GY	Wall Bracket	1 lb.	1	Each	<del>64.00</del>
21	BSX-TBASEGY	T-Base Foot	6 lbs.	1	Each	<del>47.00</del>

Prices subject to change without notice. Visit our website for the latest pricing and product information.



# Seating

Get comfortable anywhere, any time.



**Just right chairs for everywhere**—today's flexible workspaces require a variety of seating and you'll find them all here: welcoming styles for reception areas; supportive, adaptable designs for long hours at a desk; and nesting, stacking and folding styles great for collaborative areas that need to morph in a matter of minutes. So sit back and relax, we've got your seating solution covered.

Reception Room	71-79
Leather & Vinyl	81-95
Mesh	96-113
Office	114-127
24/7	132
Big & Tall	137-140
Stools	128-136, 141-143
Nesting/Stacking/Folding	147-154
Chair Mats & Casters	155-160
Footrests & Back Supports	161-164





Black Leather (SB11) / Mahogany (N)



Black Leather (SB11) / Mahogany (N)

**HON.**

## Circulate™ Lounge Seating

**Thick and deep cushions provide support and comfort.**

- Tailored stitching for professional look.
- Backed by the HON Limited 5-Year Warranty.
- Wood frame construction provides durability and strength.

ID No.	Finish/Color	W x D x H	Shpg. Wt.	Unit	Price
<b>A SOFA</b>					
1	BSX-VL873SB11	Black Leather	73" x 28¾" x 32"	122 lbs.	Each <del>1,926.00</del>
<b>B LOVE SEAT</b>					
2	BSX-VL872SB11	Black Leather	53½" x 28¾" x 32"	76 lbs.	Each <del>1,542.00</del>
<b>C CLUB CHAIR</b>					
Supports up to 250 lbs. Seat: 21½" x 21". Back: 30" x 18½". Overall height: 32".					
3	BSX-VL871SB11	Black Leather		51 lbs.	Each <del>1,216.00</del>

**Upholstery**  
Circulate™ Lounge & Top Flight™ Series



Black SofThread™ Leather (SB11)

**Finishes**  
Top Flight™ Series



Mahogany (N)

**Finishes**  
Laminate Tables



Black (P)

## Top Flight™ Leather Guest Chair

**Make a great first impression with these beautiful wood guest chairs.**

- Sturdy wood frame for enhanced stability.
- Luxurious SofThread™ leather upholstery for stylish sophistication.
- Ideal for reception areas and private offices.
- Backed by the HON Limited 5-Year Warranty.

ID No.	Color	Shpg. Wt.	Unit	Price
--------	-------	-----------	------	-------

**SOFTTHREAD™ LEATHER GUEST CHAIR**

Supports up to 250 lbs. Seat: 22" x 18¼". Back: 20" x 13". Overall height: 36¾".

**D FULL BACK CHAIR**

4	BSX-VL853NSB11	Black/Mahogany	35 lbs.	Each	<del>409.00</del>
---	----------------	----------------	---------	------	-------------------

**E HALF BACK CHAIR**

5	BSX-VL852NSB11	Black/Mahogany	26 lbs.	Each	<del>412.00</del>
---	----------------	----------------	---------	------	-------------------

## Laminate Occasional Tables

**Ideal for reception areas, lounges and offices.**

- Scratch-, spill- and stain-resistant laminate stands up to heavy use.
- Coffee table has additional shelf for magazine storage.
- Easy-to-assemble.
- Backed by the HON Full Lifetime Warranty.

ID No.	Color	Size	Shpg. Wt.	Unit	Price
--------	-------	------	-----------	------	-------

**F COFFEE TABLE**

6	BSX-BLH3160P	Black	42" x 20" x 16"	24 lbs.	Each <del>249.00</del>
---	--------------	-------	-----------------	---------	------------------------

**G CORNER TABLE**

7	BSX-BLH3170P	Black	24" x 24" x 20"	9 lbs.	Each <del>199.00</del>
---	--------------	-------	-----------------	--------	------------------------

Prices subject to change without notice.

Visit our website for the latest pricing and product information.

# Reception Room Seating



## Upholstery Reception Lounge Series

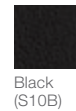

## Finishes Valencia Series

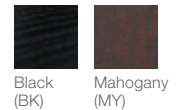

## Alera® Reception Lounge Sofa Series

Classic simple lines, for use in any reception or lounge configurations.

- Richly cushioned seats and back, for comfort.
- Fully assembled; just attach legs.
- Soft black leather with black wood pyramid legs.
- Leveling glides for stability.
- Manufacturer's limited five-year warranty.
- Meets or exceeds ANSI/BIFMA Standards.

ID No.	Finish/Color	W x D x H	Shpg. Wt.	Unit	Price
<b>A SOFA</b>					
1	ALE-RL21LS10B	Black	77" x 31½" x 32"	110 lbs.	Each <del>1,525.00</del>
<b>B LOVE SEAT</b>					
2	ALE-RL22LS10B	Black	55½" x 31½" x 32"	75 lbs.	Each <del>1,125.00</del>
<b>C CLUB CHAIR</b>					
3	ALE-RL23LS10B	Black	35" x 31½" x 32"	64 lbs.	Each <del>855.00</del>

## Alera® Valencia™ Series Occasional Tables

Simple classic design blends seamlessly into any decor.

- Durable woodgrain laminate is water-, scratch- and dent-resistant featuring 3 mm protective edge banding.
- Leveling glides to compensate for uneven floors.
- Easy to assemble, just add legs.
- Manufacturer's limited five-year warranty.
- Meets or exceeds ANSI/BIFMA Standards.

ID No.	Color	Size	Shpg. Wt.	Unit	Price
<b>D COFFEE TABLE</b>					
4	ALE-VA7548BK	Black	47¼" x 20" x 16¾"	42 lbs.	Each <del>295.00</del>
5	ALE-VA7548MY	Mahogany	47¼" x 20" x 16¾"	42 lbs.	Each <del>295.00</del>
<b>E END TABLE</b>					
6	ALE-VA7520BK	Black	23¾" x 20" x 20¾"	27 lbs.	Each <del>179.00</del>
7	ALE-VA7520MY	Mahogany	23¾" x 20" x 20¾"	27 lbs.	Each <del>179.00</del>



## Alera® QUB Series

Contemporary geometric reception room sectional set can be configured for endless possibilities.

- Tufted seat design with straight backs and arms for a modern yet comfortable look.
- Silver steel frames and legs add style.
- Manufacturer's limited five-year warranty.
- Contains 5% post-consumer recycled content, 35% total recycled content.
- Meets or exceeds ANSI/BIFMA Standards.   

ID No.	Finish/Color	W × D × H	Shpg. Wt.	Unit	Price
<b>A CORNER SECTIONAL</b>					
Corner sectional can be configured with armless sectional and ottoman.					
1	ALE-QB8016	Black	26% × 26% × 30½"	54 lbs.	Each <del>570.00</del>
<b>B ARMLESS L SECTIONAL</b>					
Armless sectional can be configured with corner sectional and ottoman.					
2	ALE-QB8116	Black	26% × 26% × 30½"	45 lbs.	Each <del>505.00</del>
<b>C POWERED ARMLESS L SECTIONAL</b>					
Armless sectional can be configured with corner sectional and ottoman.					
3	ALE-QB8116P	Black	26% × 26% × 30½"	46 lbs.	Each <del>570.00</del>
<b>D OTTOMAN</b>					
Ottoman can be configured with corner and armless sectional. Can be placed to create two-sided seating with armless sectional when placed back-to-back.					
4	ALE-QB8216	Black	26% × 21½ × 17½"	33 lbs.	Each <del>450.00</del>

## Alera® Reception Lounge 600 Series

- Stylish wood finish, soft leather and enhanced padding makes your guests feel right at home.
- Full-sided leather arms.
- Sturdy wooden, four-leg base.
- Uniformly cushioned back and seat for added comfort.
- Manufacturer's limited five-year warranty.
- Meets or exceeds ANSI/BIFMA Standards. 

ID No.	Color	Shpg. Wt.	Unit	Price
<b>E GUEST CHAIR</b>				
Supports up to 275 lbs. Seat: 19% × 19%. Back: 22% × 22%. Overall height: 34%.				
5	ALE-RL6419M	Black/Mahogany	33 lbs.	Each <del>390.00</del>

## Alera® Reception Lounge 500 Series

Handsome, handcrafted hardwood seating.

- Rich glossy mahogany for a fine finish.
- Cushioned leather upholstery for both comfort and style.
- Manufacturer's limited five-year warranty.
- Meets or exceeds ANSI/BIFMA Standards. 

ID No.	Color	Shpg. Wt.	Unit	Price
<b>F ARCH BACK SOLID WOOD CHAIR</b>				
Classic full arched back design with leather upholstery front and back. Supports up to 275 lbs. Seat: 22" × 17½". Back: 18% × 14½". Overall height: 32%.				
6	ALE-RL5219M	Black/Mahogany	31 lbs.	Each <del>550.00</del>

## Alera® Reception Lounge 700 Series

Comfortably sized reception chairs and tables are easily configurable to fit any waiting room.

- Stylish wood finish, durable fabric, and enhanced padding makes your guests feel right at home.
- Sturdy ganging coffee tables fit between chairs or corners.
- Leveling glides help compensate for uneven floors.
- Manufacturer's limited five-year warranty.
- Meets or exceeds ANSI/BIFMA Standards. 

ID No.	Color	Shpg. Wt.	Unit	Price
<b>G GUEST CHAIR</b>				
Supports up to 275 lbs. Seat: 21½ × 24%. Back: 21½ × 17%. Overall height: 35%.				
7	ALE-RL7611M	Black/Mahogany	31 lbs.	Each <del>445.00</del>

Finish  
700 Series



Mahogany

Upholstery  
700 Series



Black

Upholstery  
500 Series



Black  
Leather

# Reception Room Seating



The back floats above seat, so cleaning is simple.



**Upholstery**  
Lounge Seating



Black SofThread™  
Leather (SB11)

**Finishes**  
Occasional Tables



Black  
(P)

**HON.**

## Corral™ Lounge Seating

Discover excellence without expense.

- Contemporary geometric design sets the tone for a modern visitor space.
- Seat cushion is engineered for exceptional comfort, featuring individually wrapped coil springs to reduce pressure points.
- Durable platinum steel support legs withstand frequent moving and rearrangement.
- Back cushion has a clean-out space for easy maintenance.
- Easy to assemble and can be set up in minutes.
- Backed by the HON Limited 5-Year Warranty.

ID No. Finish/Color W x D x H Shpg. Wt. Unit Price

**A VL888 SOFA**

Back floats above the seat and the extra-wide seat cushions provide ample room for two people.

**SofThread™ Leather**

1 BSX-VL888SB11 Black 67" x 28" x 30½" 79 lbs. Each ~~1,199.00~~

**B VL887 CLUB CHAIR**

Supports up to 250 lbs. Seat: 22¼" x 19¾". Back: 22¼" x 30½". Overall height: 30½".

**SofThread™ Leather**

2 BSX-VL887SB11 Black 51 lbs. Each ~~995.00~~



## Modern Occasional Tables

Discover excellence without expense.

- A contemporary addition to any lobby, waiting room or executive office.
- Scratch-, spill- and stain-resistant laminate withstands heavy use.
- Platinum tubular steel frame stands up to frequent handling.
- Backed by the HON Limited 5-Year Warranty.

ID No. Color Size Shpg. Wt. Unit Price

**C COFFEE TABLE**

Melamine top.

3 BSX-HML8852P Black 48" x 24" x 15¾" 39 lbs. Each ~~241.00~~

**D CORNER TABLE**

Melamine top.

4 BSX-HML8851P Black 24" x 24" x 17¾" 24 lbs. Each ~~490.00~~

**E CANTILEVER TABLE**

One-piece cantilever leg with cross beam construction for greater rigidity and durability. Use as an end table, portable worksurface or space divider. Melamine top.

5 BSX-HML8858P Black 24" x 15" x 20¾" 13 lbs. Each ~~481.00~~





## Alera® Reception Lounge WL Series

Configure with sofas and tables to create reception, lounge, conference, and waiting rooms.

- An economical choice for reception seating.
- Strong wood frame structure with fabric or leather upholstery.
- Leveling glides help compensate for uneven floors.
- Manufacturer's limited five-year warranty.
- Contains 5% post-consumer recycled content, 30% total recycled content.
- Meets or exceeds ANSI/BIFMA Standards.



ID No.	Finish/Color	W × D × H	Shpg. Wt.	Unit	Price
--------	--------------	-----------	-----------	------	-------

### A 3-SEAT SOFA

1	ALE-RL2319M	Black/Mahogany	65¾" × 26½" × 33"	66 lbs.	Each	<del>965.00</del>
---	-------------	----------------	-------------------	---------	------	-------------------

### B LOVESEAT

An economical choice for reception seating. Mahogany wood frame with soft leather upholstery. Supports up to 500 lbs.

2	ALE-RL2219M	Black/Mahogany	44¾" × 26½" × 33"	53 lbs.	Each	<del>730.00</del>
---	-------------	----------------	-------------------	---------	------	-------------------

### C BENCH

Mahogany wood frame with soft leather upholstery. Richly padded and generously sized seating surface. Great to help divide seating areas. Supports up to 750 lbs.

### Three-Seater

3	ALE-RL2419M	Black/Mahogany	65¾" × 22¼" × 22¾"	60 lbs.	Each	<del>710.00</del>
---	-------------	----------------	--------------------	---------	------	-------------------

### D WOOD GUEST CHAIR

Wood frame with fabric or soft leather upholstery. Leveling glides for stability. Supports up to 275 lbs. Seat: 20¾" × 20¾". Back: 20¾" × 17¾". Overall height: 33¼".

### Leather

4	ALE-RL4319W	Black/Walnut		30 lbs.	Each	<del>390.00</del>
5	ALE-RL4319C	Black/Cherry		30 lbs.	Each	<del>390.00</del>
6	ALE-RL4319E	Black/Espresso		30 lbs.	Each	<del>390.00</del>
7	ALE-RL4319M	Black/Mahogany		30 lbs.	Each	<del>390.00</del>

### Fabric

8	ALE-RL4351M	Tan/Mahogany		29 lbs.	Each	<del>390.00</del>
---	-------------	--------------	--	---------	------	-------------------

## Captain Series

Modern captain's chairs with a commanding style.

- Make a statement at your desk or in the conference room.
- Cushioned seat and back with durable fabric upholstery.
- Contoured rounded back and arms for the perfect support.
- Extended seat edge to help reduce pressure points at the back of the knee.
- Chrome base.
- Manufacturer's limited five-year warranty.
- Meets or exceeds ANSI/BIFMA Standards.

ID No.	Color	Shpg. Wt.	Unit	Price
--------	-------	-----------	------	-------

### E GUEST CHAIR

Supports up to 275 lbs. Seat: 19¾" × 18¾". Back: 21½" × 11¼". Overall height: 30¼".

9	ALE-CS4351	Gray Tweed	25 lbs.	Each	<del>249.00</del>
---	------------	------------	---------	------	-------------------

### Upholstery WL Series

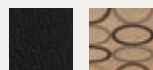

Black Tan

### Finishes WL Series

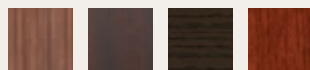

Walnut Mahogany Espresso Cherry

### Upholstery Captain Series



Gray Tweed



A

IV Series



Fabric



Leather



Mesh

Eikon Series



Black



B

Black



C

Black



Sold two per carton

Sorrento Series



Black



D



## Alera® IV Series

- Versatile line of stacking chairs and stools.
- Perfect for common areas, waiting rooms and guest seating.
- Contoured back offers built-in lumbar support.
- Manufacturer's limited five-year warranty.
- Contains 5% post-consumer recycled content, 30% total recycled content.
- Meets or exceeds ANSI/BIFMA Standards.

ID No.	Color	Shpg. Wt.	Qty.	Unit	Price
--------	-------	-----------	------	------	-------

### A GUEST CHAIR

Supports up to 270 lbs. Seat: 19¼" × 19¼". Back: 14" × 18¾". Overall height: 33".

#### Fabric Back/Seat

1	ALE-IV4317A	Black	47 lbs.	2	Carton	<del>469.00</del>
---	-------------	-------	---------	---	--------	-------------------

#### Leather Back/Seat

2	ALE-IV4319A	Black	47 lbs.	2	Carton	<del>485.00</del>
---	-------------	-------	---------	---	--------	-------------------

#### Mesh Back/Fabric Seat—Seat Back: 13¾" × 18¾"

3	ALE-IV4314A	Black	50 lbs.	2	Carton	<del>499.00</del>
---	-------------	-------	---------	---	--------	-------------------

## Alera® Eikon Series

Contemporary breathable, vented back.

- Contoured mesh back for lumbar support with cushioned mesh seat.
- Durable steel frame with textured matte black finish.
- Great for use as guest seating or in training rooms.
- Fully assembled; just add glides for fixed use or casters for mobility.
- Stacks up to four high (two chairs per carton).
- Manufacturer's limited five-year warranty.
- Meets or exceeds ANSI/BIFMA Standards.

ID No.	Color	Shpg. Wt.	Qty.	Unit	Price
--------	-------	-----------	------	------	-------

### B EIKON SERIES STACKING MESH GUEST CHAIR

Supports up to 275 lbs. Seat: 18½" × 18½". Back: 17¾" × 11¼". Overall height: 33½".

4	ALE-EK43ME10B	Black	48 lbs.	2	Carton	<del>575.00</del>
---	---------------	-------	---------	---	--------	-------------------

## Alera® Sorrento Series

Perfect for waiting areas, conference rooms or guest seating.

- Durable and stylish black faux leather upholstery is PVC-free.
- Cushioned seat and base with sturdy black straight steel legs.
- Stacks up to four high.
- Manufacturer's limited five-year warranty.
- Meets or exceeds ANSI/BIFMA Standards.

ID No.	Color	Shpg. Wt.	Qty.	Unit	Price
--------	-------	-----------	------	------	-------

### C STACKING GUEST CHAIR WITH ULTRA CUSHION

Supports up to 275 lbs. Seat: 20¾" × 19¾". Back: 20¼" × 12¾". Overall height: 33¾".

5	ALE-UT6816	Black	46 lbs.	2	Carton	<del>445.00</del>
---	------------	-------	---------	---	--------	-------------------

### D STACKING GUEST CHAIR WITH STANDARD CUSHION

Supports up to 275 lbs. Seat: 17" × 18". Back: 17½" × 9". Overall height: 32".

6	ALE-ST6716A	Black	37 lbs.	2	Carton	<del>299.00</del>
---	-------------	-------	---------	---	--------	-------------------

#### Armless

7	ALE-ST6716	Black	37 lbs.	2	Carton	<del>249.00</del>
---	------------	-------	---------	---	--------	-------------------

\* Contains 5% post-consumer recycled content, 30% total recycled content.



Great Service

We can help you with selection & solutions.



metalLounge Series



Genaro Series



Ispara Series



## Alera® metaLounge Series

- Stylish and flexible design for your high-traffic areas.
- Ideal for entryway, reception, and waiting rooms.
- Metal guest chair is easy to maintain and clean with anti-microbial upholstery and clean-out gap.
- Strong metal frame withstands heavy use.
- Wall-saver legs flair out to protect walls from accidental bumps.
- Polyurethane arms are comfortable and long-lasting.
- Waterfall seat design relieves pressure points at the back of the knees.
- Manufacturer's limited five-year warranty.
- Meets or exceeds ANSI/BIFMA Standards.
- Contains 5% post-consumer recycled content, 30% total recycled content. ♻️



ID No.	Color	Shpg. Wt.	Unit	Price
--------	-------	-----------	------	-------

**A BARIATRIC GUEST CHAIR**  
Love seat design can accommodate up to two people, but is perfect for one. Supports up to 450 lbs. Seat: 27½" × 23¼". Back: 27½" × 18½". Overall height: 33¾".

**B MID-BACK GUEST CHAIR**  
Supports up to 275 lbs. Seat: 21½" × 23¾". Back: 20¾" × 18½". Overall height: 33¾".

**C HIGH-BACK GUEST CHAIR**  
Supports up to 275 lbs. Seat: 21¾" × 23¾". Back: 20¾" × 29¼". Overall height: 43¾".

**D HIGH-BACK GUEST CHAIR**  
Supports up to 275 lbs. Seat: 21½" × 20¾". Back: 20½" × 21¾". Overall height: 36¾".

**E SLED BASE GUEST CHAIR**  
Supports up to 275 lbs. Seat: 20¼" × 19¼". Back: 19¾" × 17". Overall height: 34".

**F ARMLESS CUBE CHAIR**  
Supports up to 400 lbs. Seat: 26¾" × 25¼". Back: 26" × 16½". Overall height: 30".

**G CUBE OTTOMAN**

**H GUEST CHAIR**  
Supports up to 275 lbs. Seat: 22" × 20¾". Back: 21¾" × 22". Overall height: 37¾".

ID No.	Color	Shpg. Wt.	Unit	Price
--------	-------	-----------	------	-------

**D HIGH-BACK GUEST CHAIR**  
Supports up to 275 lbs. Seat: 21½" × 20¾". Back: 20½" × 21¾". Overall height: 36¾".

**E SLED BASE GUEST CHAIR**  
Supports up to 275 lbs. Seat: 20¼" × 19¼". Back: 19¾" × 17". Overall height: 34".

**Faux Leather**

**Fabric**

## Alera® Ispara Series

Contemporary geometric styling in soft durable leather.

- Configure your reception area or waiting room with these chairs and ottomans.
- Modular pieces fit even the most difficult layouts.
- Heavy-duty silver steel structure withstands constant use and movement.
- Leveling glides for stability.
- Manufacturer's limited five-year warranty.
- Meets or exceeds ANSI/BIFMA Standards. ✖️

ID No.	Color	W × D × H	Shpg. Wt.	Unit	Price
--------	-------	-----------	-----------	------	-------

**F ARMLESS CUBE CHAIR**  
Supports up to 400 lbs. Seat: 26¾" × 25¼". Back: 26" × 16½". Overall height: 30".

**G CUBE OTTOMAN**

**H GUEST CHAIR**  
Supports up to 275 lbs. Seat: 22" × 20¾". Back: 21¾" × 22". Overall height: 37¾".

ID No.	Color	Shpg. Wt.	Unit	Price
--------	-------	-----------	------	-------

**F ARMLESS CUBE CHAIR**  
Supports up to 400 lbs. Seat: 26¾" × 25¼". Back: 26" × 16½". Overall height: 30".

**G CUBE OTTOMAN**

**H GUEST CHAIR**  
Supports up to 275 lbs. Seat: 22" × 20¾". Back: 21¾" × 22". Overall height: 37¾".

ID No.	Color	Shpg. Wt.	Unit	Price
--------	-------	-----------	------	-------

**H GUEST CHAIR**  
Supports up to 275 lbs. Seat: 22" × 20¾". Back: 21¾" × 22". Overall height: 37¾".

## Alera® Genaro Series

Clean, classic lines complement any office environment.

- Configure to create reception, lounge, conference, and waiting rooms.
- Thickly padded for maximum comfort.
- Durable upholstery withstands everyday use.
- Padded armrests for soft support.
- Sturdy black steel sled base.
- Manufacturer's limited five-year warranty.
- Meets or exceeds ANSI/BIFMA Standards. ✖️

ID No.	Color	Shpg. Wt.	Unit	Price
--------	-------	-----------	------	-------

**D HIGH-BACK GUEST CHAIR**  
Supports up to 275 lbs. Seat: 21½" × 20¾". Back: 20½" × 21¾". Overall height: 36¾".

**E SLED BASE GUEST CHAIR**  
Supports up to 275 lbs. Seat: 20¼" × 19¼". Back: 19¾" × 17". Overall height: 34".

**Faux Leather**

**Fabric**

ID No.	Color	Shpg. Wt.	Unit	Price
--------	-------	-----------	------	-------

**H GUEST CHAIR**  
Supports up to 275 lbs. Seat: 22" × 20¾". Back: 21¾" × 22". Overall height: 37¾".

ID No.	Color	Shpg. Wt.	Unit	Price
--------	-------	-----------	------	-------

**H GUEST CHAIR**  
Supports up to 275 lbs. Seat: 22" × 20¾". Back: 21¾" × 22". Overall height: 37¾".

Prices subject to change without notice.

Visit our website for the latest pricing and product information.

# Reception Room Desk



Reception Station

## Preferred Settings

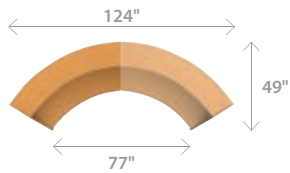

**2 Unit Reception 2,709.93**

Qty.	Item No.	Description
1	LIT-RC290CH	Reception Desk
1	LIT-RC295CH	Reception Desk Add-On

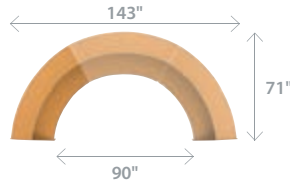

**3 Unit Reception 4,007.78**

Qty.	Item No.	Description
1	LIT-RC290CH	Reception Desk
2	LIT-RC295CH	Reception Desk Add-On

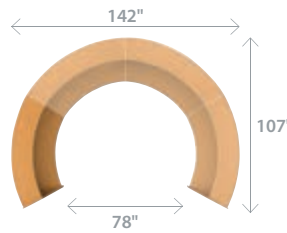

**4 Unit Reception 5,305.63**

Qty.	Item No.	Description
1	LIT-RC290CH	Reception Desk
3	LIT-RC295CH	Reception Desk Add-On

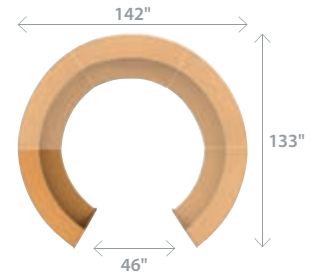

**5 Unit Reception 6,603.48**

Qty.	Item No.	Description
1	LIT-RC290CH	Reception Desk
4	LIT-RC295CH	Reception Desk Add-On

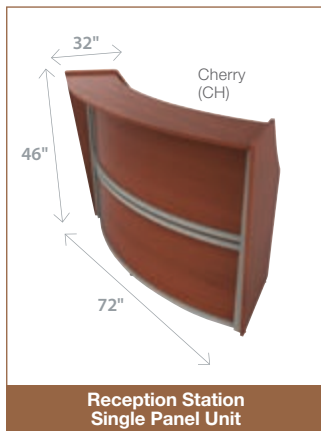

Reception Station Single Panel Unit

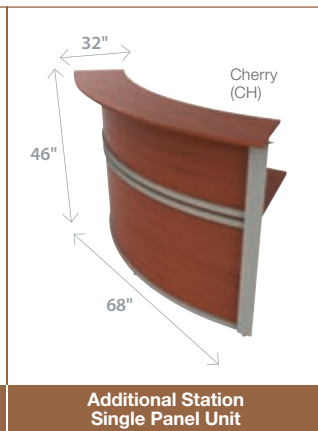

Additional Station Single Panel Unit



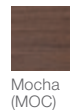
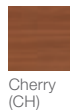

Requires additional lead time and cannot be returned.



## Reception Desks

Modernize your environment with warm, welcoming reception desks.

- Build your reception station to fit your unique environment and space.
- Click and Done system allows easy assembly -- no tools required.
- Meets or Exceeds ANSI/BIFMA Standards.   

ID No.	Color	W x D x H	Shpg. Wt.	Unit	Price
<b>A RECEPTION DESK</b>					
Features a unified, half-circle design.					
1	LIT-RC290CH	Cherry	72" x 32" x 46"	146 lbs.	Each <del>4,412.00</del>
2	LIT-RC290MOC	Mocha	72" x 32" x 46"	146 lbs.	Each <del>4,412.00</del>
3	LIT-RC290WH	White	72" x 32" x 46"	146 lbs.	Each <del>4,412.00</del>
<b>B RECEPTION DESK ADD-ON</b>					
Turn your half-circle reception desk into a fully-enclosed full-circle unit.					
4	LIT-RC295CH	Cherry	68" x 32" x 46"	109 lbs.	Each <del>1,297.85</del>
5	LIT-RC295MOC	Mocha	68" x 32" x 46"	109 lbs.	Each <del>1,297.85</del>
6	LIT-RC295WH	White	68" x 32" x 46"	109 lbs.	Each <del>1,297.85</del>





Reception Station

## Preferred Settings

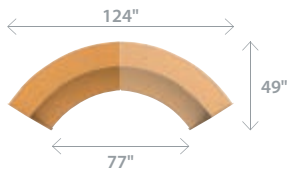

2 Unit Reception **3,065.81**

Qty.	Item No.	Description
1	LIT-RC310CH	<b>PolyCarbonate Reception Desk</b>
1	LIT-RC315CH	<b>PolyCarbonate Reception Desk Add-On</b>

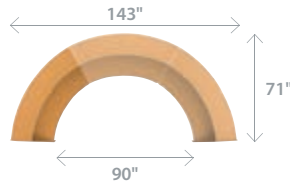

3 Unit Reception **4,506.59**

Qty.	Item No.	Description
1	LIT-RC310CH	<b>PolyCarbonate Reception Desk</b>
2	LIT-RC315CH	<b>PolyCarbonate Reception Desk Add-On</b>

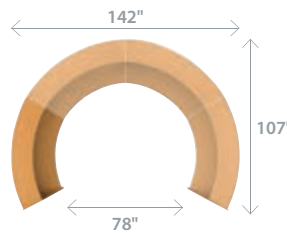

4 Unit Reception **5,947.37**

Qty.	Item No.	Description
1	LIT-RC310CH	<b>PolyCarbonate Reception Desk</b>
3	LIT-RC315CH	<b>PolyCarbonate Reception Desk Add-On</b>

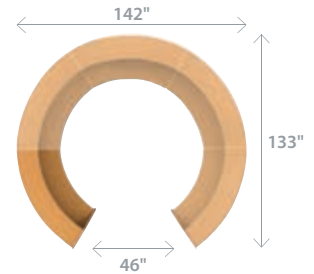

5 Unit Reception **7,388.15**

Qty.	Item No.	Description
1	LIT-RC310CH	<b>PolyCarbonate Reception Desk</b>
4	LIT-RC315CH	<b>PolyCarbonate Reception Desk Add-On</b>

**LI** linea italia<sup>®</sup>  
by CRISA



## Reception Desks

Modernize your environment with warm, welcoming reception desks.

- Build your reception station to fit your unique environment and space.
- Click and Done system allows easy assembly—no tools required.
- Meets or Exceeds ANSI/BIFMA Standards.

ID No.	Color	W × D × H	Shpg. Wt.	Unit	Price
<b>A RECEPTION DESK W/ POLYCARBONATE TOP</b>					
Features a two-tone, full-circle design with a translucent top panel.					
1	LIT-RC310CH	Cherry	72" × 32" × 46"	148 lbs.	Each 1,625.03
2	LIT-RC310MOC	Mocha	72" × 32" × 46"	148 lbs.	Each 1,625.03
3	LIT-RC310WH	White	72" × 32" × 46"	148 lbs.	Each 1,625.03
<b>B RECEPTION DESK ADD-ON</b>					
4	LIT-RC315CH	Cherry	68" × 32" × 46"	109 lbs.	Each 1,440.78
5	LIT-RC315MOC	Mocha	68" × 32" × 46"	109 lbs.	Each 1,440.78
6	LIT-RC315WH	White	68" × 32" × 46"	109 lbs.	Each 1,440.78

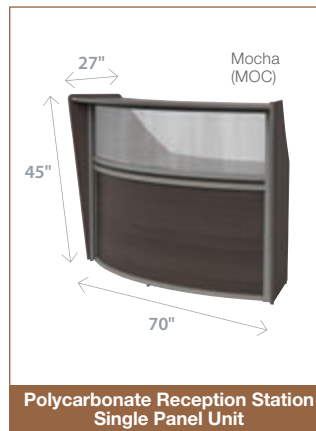

Polycarbonate Reception Station Single Panel Unit

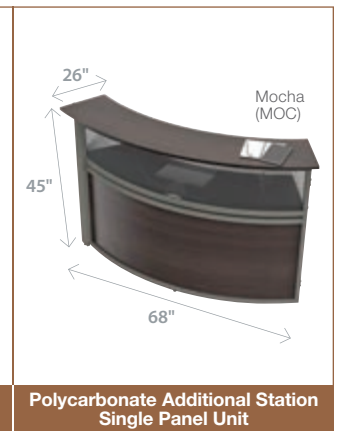

Polycarbonate Additional Station Single Panel Unit



# Buying Guide Chair Features

Find the functions you're looking for using the following icons shown throughout the seating section.



**Pneumatic Seat Height Adjustment**

Regulates seat height relative to the floor so that feet are flat on the floor—supports better circulation.



**Back Height Adjustment**

Positions height of lumbar support relative to the seat cushion to alleviate back stress.



**Seat Glide Mechanism**

Seat or back moves forward or back, then locks in position to create the proper seat depth for better back support and circulation to legs.



**Tilt Tension/Tilt Lock**

Tilt allows back to recline at a 1:1 ratio to seat for a comfortable reclining position and redistribution of pressure points. Tilt tension controls the rate and ease at which the chair reclines and the lock-out tilt function keeps chair in upright position.



**Knee Tilt**

Pivot point located below front half of seat. Allows user to keep feet flat on floor while reclining. Offers increased circulation and redistribution of pressure points.



**Synchronized Knee Tilt**

Combines, at a 2:1 ratio, the smooth recline of the back with the limited front rise of the seat to keep feet on the floor and improve circulation to legs.



**Dual-Action Tilt**

Back reclines at a 2:1 ratio to seat angle creating relaxed positions while keeping feet relatively flat on the floor.



**Posture Lock**

Holds back in place in an infinite number of positions within a fixed range to offer variety in spinal alignment and weight distribution.



**Multi-Task Control**

Single lever easily adjusts seat and back angles independently, providing an infinite number of locking positions within a fixed range for customized comfort.



**Asynchronous Control**

Three levers modify: angle of back relative to seat; tilt (free float or locking); and forward tilt. Offers a wide variety of movement, spinal alignment and weight distribution.



**Dual-Clutch Posture Control**

Seat and back angles adjust independently and lock in infinite positions within a fixed range—ideal for quick adaptation to different activities and multiple users.



**Variable Synchro-Tilt**

Back reclines in a 2:1 ratio to seat angle. Chair tilts freely, locks in five positions, or tilts forward to alleviate pressure points.



**Integral Lumbar Support**

Lumbar support within the chair back is height adjustable for proper placement; alleviates back stress.



## Traditional Series



Oxblood Burgundy



A

Oxblood Burgundy/  
Mahogany



B

Oxblood Burgundy/  
Mahogany



E

Chocolate Marble/  
Walnut



C

Oxblood Burgundy/  
Mahogany



D

Oxblood Burgundy/  
Mahogany



E

Black/  
Grey Ash



Transitional Series



Black Chocolate Marble



## Alera® Traditional Series

Traditional styling with brass nailhead trim.

- Deep cushioned bankers style upholstered chairs.
- Genuine hardwood frame with a rich mahogany finish.
- Padded arms for comfort and support.
- Manufacturer's limited five-year warranty.
- Contains 5% post-consumer recycled content, 20% total recycled content.
- Meets or Exceeds ANSI/BIFMA Standards.

ID No.	Seat/Back Color	Base Color	Shpg. Wt.	Unit	Price
--------	-----------------	------------	-----------	------	-------

### A HIGH-BACK CHAIR

High-back swivel/tilt chair. Integrated bolstered headrest for enhanced comfort and style. Steel reinforced wood five-star base with casters for easy mobility. Supports up to 275 lbs. Seat: 23" × 19.63". Back: 22" × 32.88". Overall height: 44.5" to 48.38".

1	ALE-TD4136	Oxblood Burgundy/ Oxblood Burgundy	Mahogany	64 lbs.	Each	<del>629.00</del>
---	------------	---------------------------------------	----------	---------	------	-------------------

### B MID-BACK CHAIR

Mid-back swivel/tilt chair. Steel reinforced wood five-star base with casters for easy mobility. Supports up to 275 lbs. Seat: 21.63" × 19.63". Back: 21.25" × 26.38". Overall height: 38.38" to 42.38".

2	ALE-TD4236	Oxblood Burgundy/ Oxblood Burgundy	Mahogany	61 lbs.	Each	<del>765.00</del>
---	------------	---------------------------------------	----------	---------	------	-------------------

### C GUEST ARM CHAIR WITH CASTERS

Traditional "bankers" styling with straight wood legs. Supports up to 275 lbs. Seat: 22.5" × 20.13". Back: 20.88" × 8.63". Overall height: 29.5".

3	ALE-TDC4336	Oxblood Burgundy/ Oxblood Burgundy	Mahogany	31 lbs.	Each	<del>599.00</del>
---	-------------	---------------------------------------	----------	---------	------	-------------------

### D GUEST ARM CHAIR

Traditional "bankers" styling with straight wood legs. Supports up to 275 lbs. Seat: 22.5" × 20.13". Back: 20.88" × 8.63". Overall height: 29.5".

4	ALE-TD4336	Oxblood Burgundy/ Oxblood Burgundy	Mahogany	31 lbs.	Each	<del>449.00</del>
---	------------	---------------------------------------	----------	---------	------	-------------------

## Alera® Transitional Series

Add a sense of sophistication and warmth to your office.

- Classic wood and leather styling in warm walnut finish and marbled chocolate leather.
- Individually wrapped coil-springs inside a generously cushioned seat provides exceptional mattress-like comfort all day long.
- Distinctive leather padded armrests.
- Steel reinforced walnut wood base provides exceptional strength and durability.
- Waterfall seat edge reduces pressure points at the back of the knee.
- Manufacturer's limited five-year warranty.
- Meets or Exceeds ANSI/BIFMA Standards.

ID No.	Seat/Back Color	Base Color	Shpg. Wt.	Unit	Price
--------	-----------------	------------	-----------	------	-------

### E EXECUTIVE WOOD CHAIR

Supports up to 275 lbs. Seat: 23" × 21". Back: 21.63" × 29.5". Overall height: 42.75" to 46.5".

**Leather**—Classic Wood & Leather Styling

5	ALE-TS4119G	Black/Black	Gray Ash	63 lbs.	Each	<del>635.00</del>
6	ALE-TS4159W	Chocolate Marble/ Chocolate Marble	Walnut	58 lbs.	Each	<del>695.00</del>

For more information on additional chair features see page 80.



Pneumatic  
Seat Height  
Adjustment



Tilt/Tension/  
Tilt Lock

Prices subject to change without notice.  
Visit our website for the latest pricing and product information.

# Seating Leather and Vinyl



**A**

Black  
Leather



Responsive memory foam in the executive and managerial chairs' seat and back eliminates pressure points and provides lasting comfort.



**B**

Burgundy  
Leather

Pillow-Soft®

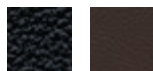

Black  
Leather  
(SR11)    Burgundy  
Leather  
(SR69)

See the full Pillow-Soft® series in the Office Chairs Section.

Finishes  
TopFlight™ Series



Mahogany  
(N)

Upholstery



Black  
Leather  
(SB11)



**C**

Black Leather  
(SB11)/  
Mahogany (N)



**D**

Black Leather  
(SB11)/  
Mahogany (N)



Black Leather  
(SB11)/  
Mahogany (N)

**HON.**



## Pillow-Soft® Executive Seating

Superb comfort and attractive styling appropriate for executive, managerial and conference settings.

- Ergonomic support you need throughout the day, with plush cushioning that makes sitting more comfortable than ever.
- Plush, tufted back cushion with recess at the base to cradle the lumbar region.
- Backed by the HON Full Lifetime Warranty.
- Contains 4% pre-consumer recycled content, 26% post-consumer recycled content.
- Level 2 Certified; Meets or Exceeds ANSI/BIFMA Standards; SCS Indoor Advantage Gold Certified.

ID No.	Seat/Back Color	Base Color	Shpg. Wt.	Unit	Price
--------	-----------------	------------	-----------	------	-------

### A EXECUTIVE HIGH-BACK CHAIR

Simple, understandable controls include seat height to fit your body, and center-tilt to provide comfort. Supports up to 300 lbs. Seat: 21" x 22". Back: 22" x 25". Overall height: 42" to 46.5".

**Leather**—Standard-loop arms.

1	HON-2091SR11T	Black/Black	Black	57 lbs.	Each	<del>770.00</del>
2	HON-2091SR69T	Burgundy/Burgundy	Black	57 lbs.	Each	<del>770.00</del>

### B GUEST CHAIR

Supports up to 300 lbs. Seat: 21.5" x 20.75". Back: 21.5" x 19.25". Overall height: 36".

**Leather**

3	HON-2093SR11T	Black/Black	Black	38 lbs.	Each	<del>621.00</del>
4	HON-2093SR69T	Burgundy/Burgundy	Black	38 lbs.	Each	<del>597.00</del>

For more information on additional chair features see page 80.



Pneumatic  
Seat Height  
Adjustment



Tilt Tension/  
Tilt Lock



Integral  
Lumbar  
Support

## TopFlight™ Series Leather High-Back Chair

Luxurious comfort for the contemporary office.

- Lumbar support for comfort.
- Waterfall seat front reduces pressure for improved circulation.
- Sturdy wood frame for enhanced stability.
- Upscale hardwood accents.
- Backed by the HON Limited Five-Year Warranty.

ID No.	Seat/Back Color	Base Color	Shpg. Wt.	Unit	Price
--------	-----------------	------------	-----------	------	-------

### C EXECUTIVE HIGH-BACK CHAIR

Supports up to 250 lbs. Seat: 20" x 20.5". Back: 20.5" x 27.5". Overall height: 44" to 47.5".

**SoftThread® Leather**

5	BSX-VL844NSB11	Black/Mahogany	Mahogany	58 lbs.	Each	<del>659.00</del>
---	----------------	----------------	----------	---------	------	-------------------

## TopFlight™ Leather Guest Chair

Make a great first impression with these beautiful wood guest chairs.

- Sturdy wood frame for enhanced stability.
- Luxurious SoftThread™ leather upholstery for stylish sophistication.
- Ideal for reception areas and private offices.
- Backed by the HON Limited Five-Year Warranty.

ID No.	Color	Shpg. Wt.	Unit	Price
--------	-------	-----------	------	-------

### D SOFTTHREAD™ LEATHER GUEST CHAIR

Supports up to 250 lbs. Seat: 22" x 18.25". Back: 20" x 13". Overall height: 36.38".

**Full-Back Guest Chair**

6	BSX-VL853NSB11	Black/Mahogany		35 lbs.	Each	<del>499.00</del>
---	----------------	----------------	--	---------	------	-------------------



**Half-Back Guest Chair**

7	BSX-VL852NSB11	Black/Mahogany		26 lbs.	Each	<del>412.00</del>
---	----------------	----------------	--	---------	------	-------------------





**A**

**Madaris Series**  
**Finish** **Upholstery**  
   
 Mahogany Black Leather



**B**

Black Leather





**C**

Black Leather



**D**

Cherry/  
Black Leather

**Postal Series**  
**Finish** **Upholstery**  
   
 Cherry Black Leather



Classic elegance in soft touch black leather.



Five-star base adorned with mahogany finish.



Leather padded armrests.



**E**

Black Top-Grain Leather



**F**

Black Top-Grain Leather

**Strada Series**



Black Leather (10B)



## Alera® Madaris Series

Perfect for executive, conference and general office use.

- Luxurious soft black leather upholstery.
- Padded armrests for comfort.
- Mid-range knee tilt feature keeps your feet on the floor as you recline at a more relaxed angle.
- Waterfall seat edge relieves pressure points at the back of the knees.
- Distinctive leather padded mahogany arms and five-star base.
- Manufacturer's limited five-year warranty.
- Meets or Exceeds ANSI/BIFMA Standards. 

ID No.	Seat/Back Color	Base Color	Shpg. Wt.	Unit	Price
<b>A HIGH-BACK KNEE TILT LEATHER CHAIR WITH WOOD TRIM</b>					
Supports up to 275 lbs. Seat: 21.63" × 20.25". Back: 21.5" × 31.13". Overall height: 44.25" to 47.63". 					
1	ALE-MA41LS10M	Black/Black	Mahogany	58 lbs.	Each <del>580.00</del>
<b>B MID-BACK KNEE TILT LEATHER CHAIR WITH WOOD TRIM</b>					
Supports up to 275 lbs. Seat: 21.63" × 20.25". Back: 21.5" × 24.38". Overall height: 37.38" to 41". 					
2	ALE-MA42LS10M	Black/Black	Mahogany	51 lbs.	Each <del>560.00</del>
<b>C LEATHER GUEST CHAIR WITH WOOD TRIM LEGS</b>					
Leveling glides for uneven floors. Supports up to 275 lbs. Seat: 21.63" × 20.38". Back: 21.5" × 24.38". Overall height: 35".					
3	ALE-MA43ALS10M	Black/Black	Mahogany	32 lbs.	Each <del>470.00</del>

For more information on additional chair features see page 80.

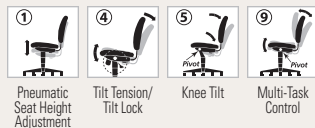

## Alera® Postal Series

Iconic wood slat office chair updated for the modern office.



- Rich cherry wood finish with leather seat.
- Durable metal reinforced wood five-star base for mobility.
- Tilt lock and tension controls rate of recline to accommodate any user.
- Manufacturer's limited five-year warranty.
- Contains 5% post-consumer recycled content, 20% total recycled content.
- Meets or Exceeds ANSI/BIFMA Standards. 

ID No.	Seat/Back Color	Base Color	Shpg. Wt.	Unit	Price
<b>D SLAT-BACK WOOD/LEATHER CHAIR</b>					
Supports up to 275 lbs. Seat: 19.88" × 17.75". Back: 19.25" × 21.13". Overall height: 31.5" to 35.5". 					
4	ALE-PC4299C	Cherry/Black	Cherry	41 lbs.	Each <del>975.00</del>

## Alera® Strada Series

Tailored seat and back.

- Tailored seat and back with top-grain leather upholstery.
- Roll armrests with padded leather arm caps.
- Waterfall seat reduces pressure at the back of knees.
- Manufacturer's limited five-year warranty.
- Meets or Exceeds ANSI/BIFMA Standards. 

ID No.	Seat/Back Color	Base Color	Shpg. Wt.	Unit	Price
<b>E HIGH-BACK SWIVEL/TILT TOP-GRAIN LEATHER CHAIR</b>					
Supports up to 275 lbs. Seat: 21" × 21.25". Back: 21" × 28.13". Overall height: 43.13" to 46.63". 					
5	ALE-SR41LS10B	Black/Black	Black	51 lbs.	Each <del>645.00</del>
<b>F MID-BACK SWIVEL/TILT TOP-GRAIN LEATHER CHAIR</b>					
Supports up to 275 lbs. Seat: 21" × 21.25". Back: 21" × 22.88". Overall height: 38.63" to 42.13". 					
6	ALE-SR42LS10B	Black/Black	Black	48 lbs.	Each <del>590.00</del>

Prices subject to change without notice.  
 Visit our website for the latest pricing and product information.

# Seating Leather and Vinyl



A

Black  
Leather



B

Black  
Leather



C

Black  
Leather



D

Black  
Leather



E

Black  
Leather



Black  
Leather



F

Black  
Leather

Work hard  
and rest easy



## SOFT CUSHIONED ANTI-FATIGUE ERGONOMIC FOOTREST

ID No.	W x D x H	Color	Unit	Price
7 ALE-FS112	14" x 19.63" x 3.75" to 7.5"	Black	Each	<del>59.00</del>



## Alera® CC Leather Series

Generously cushioned executive leather chair makes a statement with bold contrast stitching.

- A soft and highly comfortable leather chair for the busy executive.
- Plush side and seat bolsters with integrated headrest.
- Padded leather arms.
- Domed five star base with hooded casters for easy mobility.
- Manufacturer's limited five-year warranty.
- Contains 12% post-consumer recycled content, 12% total recycled content.
- Meets or Exceeds ANSI/BIFMA Standards.

ID No.	Seat/Back Color	Base Color	Shpg. Wt.	Unit	Price
--------	-----------------	------------	-----------	------	-------

### A EXECUTIVE HIGH-BACK SWIVEL/TILT LEATHER CHAIR WITH HEIGHT ADJUSTABLE ARMS

Supports up to 275 lbs.

Seat: 20.88" x 20". Back: 20.13" x 29.5". Overall height: 41.38" to 45".

1	ALE-CC4119	Black/Black	Black	42 lbs.	Each	<del>385.00</del>
---	------------	-------------	-------	---------	------	-------------------

### B EXECUTIVE HIGH-BACK SWIVEL/TILT LEATHER CHAIR WITH FIXED ARMS

Supports up to 275 lbs.

Seat: 20.88" x 20.88". Back: 20.88" x 28.38". Overall height: 41.5" to 45.25".

2	ALE-CC4119F	Black/Black	Black	41 lbs.	Each	<del>365.00</del>
---	-------------	-------------	-------	---------	------	-------------------

### C EXECUTIVE MID-BACK LEATHER CHAIR WITH HEIGHT ADJUSTABLE ARMS

Supports up to 275 lbs.

Seat: 19.63" x 19.63". Back: 19.75" x 22.63". Overall height: 35.5" to 39.13".

3	ALE-CC4219	Black/Black	Black	41 lbs.	Each	<del>280.00</del>
---	------------	-------------	-------	---------	------	-------------------

### D EXECUTIVE MID-BACK LEATHER CHAIR WITH FIXED ARMS

Supports up to 275 lbs.

Seat: 19.63" x 19.63". Back: 19.75" x 22.63". Overall height: 35.5" to 39.13".

4	ALE-CC4219F	Black/Black	Black	36 lbs.	Each	<del>260.00</del>
---	-------------	-------------	-------	---------	------	-------------------

## Fraze Chair

Ultra-soft cushions, side bolsters and lumbar bolsters for maximum support.

- Plush, thick-padded headrest and arm rests.
- Soft leather upholstery for style and comfort.
- Manufacturer's limited five-year warranty.
- Meets or Exceeds ANSI/BIFMA Standards.

ID No.	Seat/Back Color	Base Color	Shpg. Wt.	Unit	Price
--------	-----------------	------------	-----------	------	-------

### E HIGH-BACK SWIVEL/TILT LEATHER CHAIR

Supports up to 275 lbs.

Seat: 21.75" x 20.5". Back: 21.75" x 28.38". Overall height: 41.25" to 44.75".

5	ALE-FZ41LS10B	Black/Black	Black	46 lbs.	Each	<del>450.00</del>
---	---------------	-------------	-------	---------	------	-------------------

## Sparis Series

A versatile chair for management, conference and general office use.

- Soft leather upholstery.
- Built-in headrest for relaxed comfort.
- Manufacturer's limited five-year warranty.
- Meets or Exceeds ANSI/BIFMA Standards.

ID No.	Seat/Back Color	Base Color	Shpg. Wt.	Unit	Price
--------	-----------------	------------	-----------	------	-------

### F HIGH-BACK SWIVEL/TILT LEATHER CHAIR

Supports up to 275 lbs.

Seat: 20" x 20.5". Back: 20.5" x 27.38". Overall height: 42.5" to 46.88".

6	ALE-SP41LS10B	Black/Black	Black	39 lbs.	Each	<del>320.00</del>
---	---------------	-------------	-------	---------	------	-------------------

For more information on additional chair features see page 80.



## Veon Series

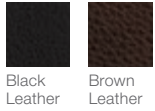

## Alera® Veon Series

### All day mattress-like comfort.

- Coil spring cushioned seat provides long-lasting comfort.
- Ergonomic side bolsters for added support plus integrated leather headrest and padded leather armrests.
- Five-star base with protective foot zones.
- Generously cushioned waterfall seat reduces pressure at the back of the knees.
- Manufacturer's limited five-year warranty.
- Contains 15% total recycled content.
- Meets or Exceeds ANSI/BIFMA Standards. ♻️ ♻️ ♻️

## Leather Guest Chair

### Generously padded leather guest chair with cushioned bolsters for extra comfort.

- Configure multiple chairs for reception rooms, guest seating, and conference rooms.
- Padded armrests for soft support.
- Sturdy steel legs.
- Manufacturer's limited five-year warranty.
- Meets or Exceeds ANSI/BIFMA Standards. ♻️

ID No.	Seat/Back Color	Base Color	Shpg. Wt.	Unit	Price
<b>A EXECUTIVE HIGH-BACK LEATHER CHAIR</b>					
Adjustable lumbar for optimal back support. Supports up to 275 lbs. Seat: 21.63" × 21.63". Back: 31" × 25.75". Overall height: 44.13" to 47". ① ④ ⑬					
1	ALE-VN4119	Black/Black	Graphite	50 lbs.	Each <del>699.00</del>
2	ALE-VN4159	Brown/Brown	Bronze	50 lbs.	Each <del>699.00</del>
<b>B LEATHER MID-BACK MANAGER'S CHAIR</b>					
Height adjustable arms. Supports up to 275 lbs. Seat: 20.88" × 20.13". Back: 20.5" × 26.13". Overall height: 40.5" to 43.25". ① ④					
3	ALE-VN5119	Black/Black	Graphite	45 lbs.	Each <del>525.00</del>
4	ALE-VN5159	Brown/Brown	Bronze	45 lbs.	Each <del>525.00</del>
<b>C LOW-BACK LEATHER TASK CHAIR</b>					
Supports up to 275 lbs. Seat: 20.5" × 18.13". Back: 19.13" × 22.63". Overall height: 36.25" to 39.13". ① ④					
5	ALE-VN6119	Black/Black	Graphite	35 lbs.	Each <del>445.00</del>
6	ALE-VN6159	Brown/Brown	Bronze	35 lbs.	Each <del>445.00</del>

ID No.	Seat/Back Color	Base Color	Shpg. Wt.	Unit	Price
<b>D GUEST CHAIR</b>					
Supports up to 275 lbs. Seat: 22" × 20.88". Back: 21.75" × 22". Overall height: 37.63".					
7	ALE-VN4319	Black/Black	Black	33 lbs.	Each <del>945.00</del>

For more information on additional chair features see page 80.



Prices subject to change without notice. Visit our website for the latest pricing and product information.

Black Fabric



**Big & TALL  
400 Lbs**



**DLS Back Health Technology:**  
Dynamic Lumbar Support  
Promotes and maintains ideal spine curvature. The lumbar self-adjusts to different posture states as you recline.



Baldwin Series Upholstery

Black Fabric

L A Z B O Y



## Commercial 2000 Series with Dynamic Lumbar Support

**Dynamic Lumbar Support, DLS, promotes and maintains ideal spine curvature. The lumbar self-adjusts to different posture states as you recline.**

- Premium La-Z-Boy® Commercial ComfortCore® with Gel Memory foam seat construction for added comfort and heat dispersal.
- Upholstered in commercial grade black bonded leather.
- Aluminum arms with polyurethane arm pads.
- Five-star aluminum base with casters for easy mobility.
- Cable actuated seat plate for seat height adjustment and tilt function.
- Manufacturer's limited ten-year warranty.
- Meets or Exceeds ANSI/BIFMA Standards.

ID No.	Seat/Back Color	Base Color	Shpg. Wt.	Unit	Price
--------	-----------------	------------	-----------	------	-------

**A HIGH-BACK EXECUTIVE CHAIR**

Supports up to 300 lbs.  
Seat: 23" x 21.75". Back: 35" x 23". Overall height: 43.5" to 46.5".

1	LZB-48957	Black/ Black	Silver	69 lbs.	Each	<del>975.00</del>
---	-----------	--------------	--------	---------	------	-------------------

**B BIG & TALL EXECUTIVE CHAIR**

Supports up to 400 lbs.  
Seat: 23.75" x 21.75". Back: 24" x 36.25". Overall height: 45" to 48".

2	LZB-48956	Black/ Black	Silver	73 lbs.	Each	<del>1,100.00</del>
---	-----------	--------------	--------	---------	------	---------------------

## Commercial 2000 Executive Chair

**Premium La-Z-Boy® Commercial ComfortCore® with Gel Memory foam seat construction for added comfort and heat dispersal.**

- Knee tilt seat plate with four point locking tilt positions
- Upholstered in commercial grade black bonded leather.
- Aluminum arms with polyurethane arm pads.
- Five-star aluminum base with casters for easy mobility.
- Manufacturer's limited ten-year warranty.
- Meets or Exceeds ANSI/BIFMA Standards.

ID No.	Seat/Back Color	Base Color	Shpg. Wt.	Unit	Price
--------	-----------------	------------	-----------	------	-------

**C HIGH-BACK EXECUTIVE CHAIR**

Supports up to 300 lbs.  
Seat: 23" x 21.75". Back: 23.75" x 35". Overall height: 45" to 48".

3	LZB-48958	Black/ Black	Silver	68 lbs.	Each	<del>900.00</del>
---	-----------	--------------	--------	---------	------	-------------------

**D BIG & TALL EXECUTIVE CHAIR**

Supports up to 400 lbs.  
Seat: 23.75" x 21.75". Back: 24.5" x 35.5". Overall height: 46" to 49".

4	LZB-48968	Black/ Black	Silver	70 lbs.	Each	<del>1,025.00</del>
---	-----------	--------------	--------	---------	------	---------------------

## Baldwin Series

**Contoured Proform molded foam seating technology with built-in lumbar support for superior comfort.**

- Upholstered in premium fabric.
- Height adjustable arms for custom comfort.
- Pneumatic lift with tilt tension adjustment and lockout feature.
- Five-star black nylon base with casters for easy mobility.
- American Chiropractic Association endorsed office seating.
- Manufacturer's limited ten-year warranty.
- Meets or Exceeds ANSI/BIFMA Standards.

ID No.	Seat/Back Color	Base Color	Shpg. Wt.	Unit	Price
--------	-----------------	------------	-----------	------	-------

**E MID BACK TASK CHAIR**

Supports up to 275 lbs.  
Seat: 21.25" x 21.5". Back: 21.5" x 27.25". Overall height: 41.25" to 44.25".

5	LZB-48825	Black/ Black	Black	55 lbs.	Each	<del>425.00</del>
---	-----------	--------------	-------	---------	------	-------------------



For more information on additional chair features see page 80.



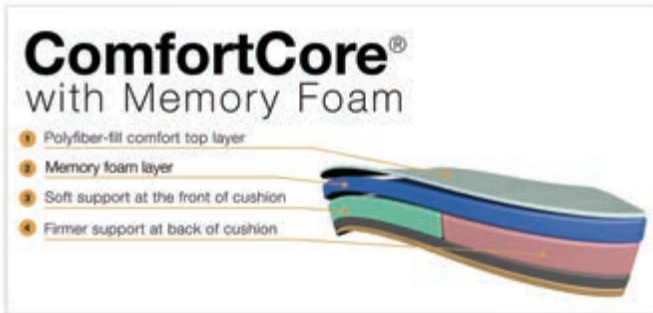

L A Z B O Y



## Woodbury Executive Chair

Premium La-Z-Boy® patented ComfortCore® Plus memory foam seat construction.

- Upholstered in commercial grade bonded leather.
- Wood arms and base finished with polyurethane coating for added durability.
- Cable actuated seat plate for seat height adjustment and tilt function.
- Manufacturer's limited ten-year warranty.
- Meets or Exceeds ANSI/BIFMA Standards.

ID No.      Seat/Back Color      Base Color      Shpg. Wt.      Unit      Price

### A BIG & TALL EXECUTIVE CHAIR

Supports up to 400 lbs.  
Seat: 24" × 23". Back: 24" × 33.75". Overall height: 45.75" to 48.75".

1	LZB-48961A	Black/Black	Weathered Gray	74 lbs.	Each	<del>650.00</del>
2	LZB-48961B	Brown/Brown	Weathered Sand	74 lbs.	Each	<del>650.00</del>

### B HIGH-BACK EXECUTIVE CHAIR

Supports up to 300 lbs.  
Seat: 22.75" × 22.75". Back: 23" × 34". Overall height: 44" to 47".

3	LZB-48962A	Black/Black	Weathered Gray	71 lbs.	Each	<del>750.00</del>
4	LZB-48962B	Brown/Brown	Weathered Sand	71 lbs.	Each	<del>750.00</del>

### C MID-BACK EXECUTIVE CHAIR

Supports up to 300 lbs.  
Seat: 21.25" × 20.75". Back: 21" × 28.25". Overall height: 38" to 41".

5	LZB-48963A	Black/Black	Weathered Gray	58 lbs.	Each	<del>700.00</del>
6	LZB-48963B	Brown/Brown	Weathered Sand	58 lbs.	Each	<del>700.00</del>

### Woodbury Series

#### Finish



#### Upholstery

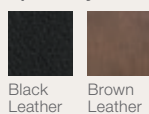

## Emerson Collection

Multi-density foam and premium memory foam for exceptional support and comfort.

- Premium bonded leather provides enhanced durability and ease of maintenance.
- Height and width adjustable arms for custom comfort.
- Easy access seat adjustment controls for seat height and tilt-lock adjustments.
- Heavy-duty nylon arms and base.
- Manufacturer's limited five-year warranty.
- Meets or Exceeds BIFMA Standards.

ID No.      Seat/Back Color      Base Color      Shpg. Wt.      Unit      Price

### D BIG & TALL TASK CHAIR

Supports up to 400 lbs.  
Seat: 22" × 21.5". Back: 22.75" × 33.75". Overall height: 44.25" to 47.25".

7	SRJ-49416BLK	Black/Black	Silver	66 lbs.	Each	<del>545.97</del>
8	SRJ-49416BRW	Brown/Brown	Silver	66 lbs.	Each	<del>545.97</del>

### E EXECUTIVE TASK CHAIR

Supports up to 300 lbs.  
Seat: 22.25" × 22". Back: 22.5" × 33.5". Overall height: 44" to 47".

9	SRJ-49710BLK	Black/Black	Silver	63 lbs.	Each	<del>498.10</del>
10	SRJ-49710BRW	Brown/Brown	Silver	63 lbs.	Each	<del>498.10</del>

### F TASK CHAIR

Supports up to 300 lbs.  
Seat: 21.25" × 19.75". Back: 21.25" × 28.25". Overall height: 39.25" to 42.25".

11	SRJ-49711BLK	Black/Black	Silver	56 lbs.	Each	<del>444.59</del>
12	SRJ-49711BRW	Brown/Brown	Silver	56 lbs.	Each	<del>444.59</del>
13	SRJ-49711GRY	Gray/Gray	Silver	56 lbs.	Each	<del>444.59</del>

### Emerson Collection

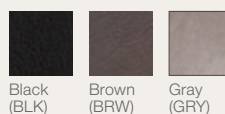

For more information on additional chair features see page 80.



## Cosset Executive Chair

SertaPedic® comfort support system with layers of molded foam, memory foam, and pocket coils.

- Upholstered in black commercial grade bonded leather.
- Pneumatic lift with tilt tension adjustment and lockout feature.
- Five-star nylon base with casters for easy mobility.
- Manufacturer's limited five-year warranty.
- Meets or Exceeds ANSI/BIFMA Standards.

ID No.	Seat/Back Color	Base Color	Shpg. Wt.	Unit	Price
--------	-----------------	------------	-----------	------	-------

### A BIG & TALL EXECUTIVE CHAIR

Pivot Reactive Ergonomic Support, PRESS, back health technology is a fully articulating backrest that offers continuous lumbar support at any back angle. Supports up to 400 lbs. Seat: 24" x 23.25". Back: 23.75" x 31.5". Overall height: 45.5" to 48.5".

1	SRJ-48964	Black/Black	Slate	60 lbs.	Each	590.00
---	-----------	-------------	-------	---------	------	--------



### ARCHES Back Health Technology:

Adjustable Reactive Contoured Healthy Spine System

Provides customized flexible kinetic lumbar support

ID No.	Seat/Back Color	Base Color	Shpg. Wt.	Unit	Price
--------	-----------------	------------	-----------	------	-------

### B HIGH-BACK EXECUTIVE CHAIR

Adjustable Reactive Contoured Ergonomic Support, ARCHES, back health technology provides customized flexible kinetic lumbar support. Supports up to 275 lbs. Seat: 22.5" x 22.5". Back: 22.5" x 30". Overall height: 43.75" to 46.75".

2	SRJ-48965	Black/Black	Slate	52 lbs.	Each	515.00
---	-----------	-------------	-------	---------	------	--------

### C MID-BACK EXECUTIVE CHAIR

Pivot Reactive Ergonomic Support, PRESS, back health technology is a fully articulating backrest that offers continuous lumbar support at any back angle. Supports up to 275 lbs. Seat: 21.5" x 22.5". Back: 21.5" x 27.5". Overall height: 41.5" to 44.5".

3	SRJ-48966	Black/Black	Slate	58 lbs.	Each	480.00
---	-----------	-------------	-------	---------	------	--------

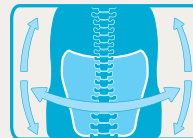

### PRESS Back Health Technology:

Pivot Reactive Ergonomic Support System

Fully articulating backrest offering continuous lumbar support at any angle

## Cosset Task Chair

Active Contoured Ergonomic Support (ACES) provides support while perching to support your back at any sitting position.

- SertaPedic® comfort support cushion system with memory foam and pocket coils.
- Upholstered in a durable Culp fabric.
- Height adjustable arms for custom comfort.
- Pneumatic lift with tilt tension adjustment and lockout feature.
- Five-star nylon base with casters for easy mobility.
- American Chiropractic Association endorsed office seating.
- Manufacturer's limited five-year warranty.
- Meets or Exceeds ANSI/BIFMA Standards.

ID No.	Seat/Back Color	Base Color	Shpg. Wt.	Unit	Price
--------	-----------------	------------	-----------	------	-------

### D ERGONOMIC TASK CHAIR

Supports up to 275 lbs. Seat: 20.75" x 21.75". Back: 20.75" x 27.25". Overall height: 38" to 41".

4	SRJ-48967A	Black/Black	Black	56 lbs.	Each	500.00
5	SRJ-48967B	Gray/Gray	Black	56 lbs.	Each	500.00



### ACES Back Health Technology:

Active Contoured Ergonomic Support

Provides back support while perching to support your back at any sitting position



A

PRESS



Big & TALL  
400 Lbs

Black  
Leather

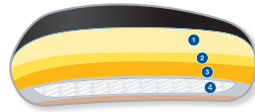

- 1 Poly Foam
- 2 Memory Foam
- 3 High Density Foam
- 4 Coils



B

ARCHES



Black  
Leather



C

PRESS



Black  
Leather

Cosset  
Executive



Black  
Leather



D

ACES



Black



D

ACES



Gray

Cosset Task Chair



Gray  
Fabric

Black  
Fabric



Pneumatic  
Seat Height  
Adjustment



Tilt Tension/  
Tilt Lock

For more information on additional chair features see page 80.



A

Black  
Leather



C

Black  
Leather



E

Black  
Leather  
(SB11)



B

Taupe  
Leather

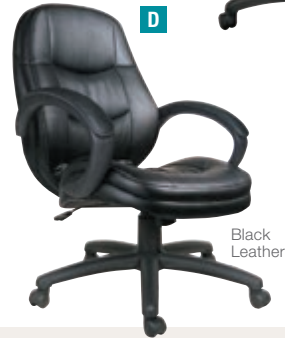

D

Black  
Leather



F

Black  
Leather  
(SB11)

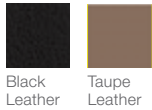

Black  
Leather

Taupe  
Leather



## Alera® YR Series

The one chair for the busy office - durability, looks and versatility for anywhere you need a seat.

- Classic modern styling in durable leather upholstery.
- Slightly arched loop arms provide the perfect positioning.
- Manufacturer's limited five-year warranty.
- Contains 5% post-consumer recycled content, 30% total recycled content.
- Meets or Exceeds ANSI/BIFMA Standards.

ID No.	Seat/Back Color	Base Color	Shpg. Wt.	Unit	Price
<b>A EXECUTIVE HIGH-BACK SWIVEL/TILT LEATHER CHAIR</b>					
Supports up to 275 lbs. Seat: 21.25" x 20.5". Back: 20.13" x 25.25". Overall height: 39.75" to 43.75".					
1	ALE-YR4119	Black/Black	Black	38 lbs.	Each <del>345.00</del>

## Alera® CA Series

Have it all with sleek, simple styling, a generously padded seat, and the luxurious feel of leather.

- Rich padded seat and back for all day comfort.
- Integrated headrest bolster.
- Adjustable T-arms with soft padded polyurethane armrests for optimal arm positioning.
- Manufacturer's limited five-year warranty.
- Meets or Exceeds ANSI/BIFMA Standards.

ID No.	Seat/Back Color	Base Color	Shpg. Wt.	Unit	Price
<b>B HIGH-BACK SWIVEL/TILT LEATHER CHAIR</b>					
Supports up to 275 lbs. Seat: 20" x 19.63". Back: 19.63" x 25.63". Overall height: 40" to 43.63".					
2	ALE-CA4119	Black/Black	Black	42 lbs.	Each <del>375.00</del>
3	ALE-CA4159	Taupe/Taupe	Black	42 lbs.	Each <del>375.00</del>

For more information on additional chair features see page 80.



1 Pneumatic  
Seat Height  
Adjustment

4 Tilt Tension/  
Tilt Lock

## Alera® PF Series

Functionality, high-style and bolstered seat cushion are ideal in any office.

- Ergonomically contoured seat and back designed for optimal support.
- Richly padded leather chair provides all-day comfort.
- Padded loop arms for ideal arm positioning and support.
- Manufacturer's limited five-year warranty.
- Contains 5% post-consumer recycled content, 30% total recycled content.
- Meets or Exceeds ANSI/BIFMA Standards.

ID No.	Seat/Back Color	Base Color	Shpg. Wt.	Unit	Price
<b>C HIGH-BACK LEATHER OFFICE CHAIR</b>					
Supports up to 275 lbs. Seat: 21.63" x 21.25". Back: 21.25" x 28.5". Overall height: 42" to 45.88".					
4	ALE-PF4119	Black/Black	Black	47 lbs.	Each <del>405.00</del>
<b>D MID-BACK LEATHER OFFICE CHAIR</b>					
Supports up to 275 lbs. Seat: 21" x 20.63". Back: 20.5" x 24.38". Overall height: 38.13" to 42.13".					
5	ALE-PF4219	Black/Black	Black	54 lbs.	Each <del>355.00</del>

## HON.

## Client™ Leather Seating

Discover excellence without expense.

- Built-in lumbar support provides extreme comfort.
- Ergonomic design aligns with the natural curve of the spine.
- Thick, deep cushions provide long-lasting comfort.
- Backed by the HON Limited Five-Year Warranty.

ID No.	Seat/Back Color	Base Color	Shpg. Wt.	Unit	Price
<b>E EXECUTIVE HIGH-BACK CHAIR</b>					
Supports up to 250 lbs. Seat: 21.5" x 20.25". Back: 21.5" x 27". Overall height: 44.25" to 47.25".					
<b>SofThread™ Leather</b>					
6	BSX-VL691SB11	Black/Black	Black	50 lbs.	Each <del>550.00</del>
<b>F GUEST CHAIR</b>					
Supports up to 250 lbs. Seat: 20.38" x 19.38". Back: 21" x 16.25". Overall height: 33.5".					
<b>SofThread™ Leather</b>					
7	BSX-VL693SB11	Black/Black	Black	38 lbs.	Each <del>361.00</del>

Prices subject to change without notice.  
Visit our website for the latest pricing and product information.



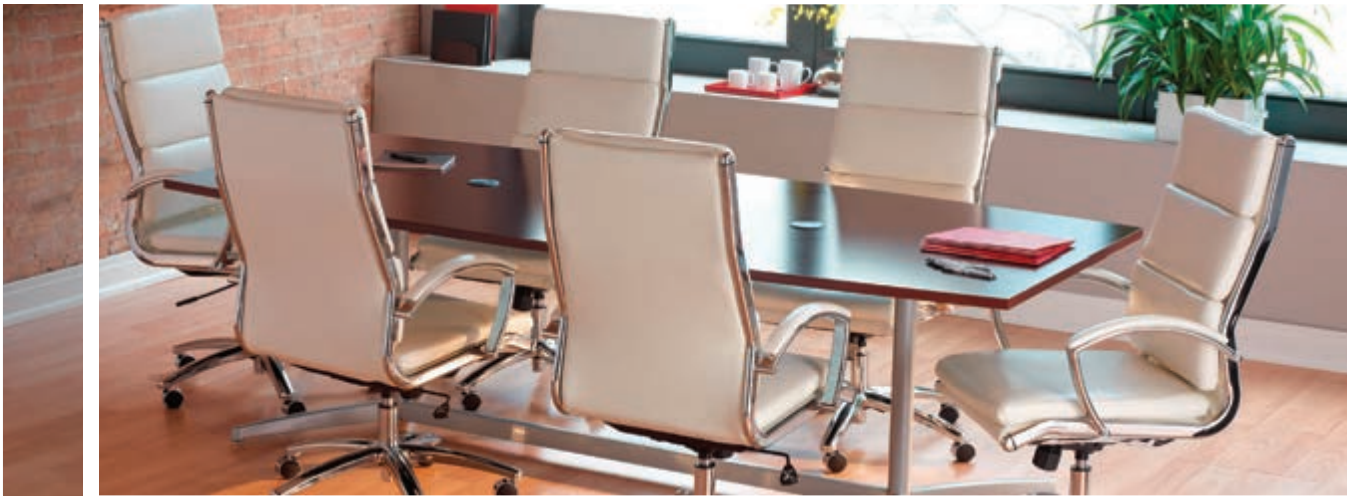

Camel Leather (59)



Shown without Arms as an Alternate Seating Solution



Black Leather (19)

Camel Leather (59)



Red Leather (39)

Stain-Resistant White Faux Leather (06)



Black Leather (19)



## Alera® Neratoli® Series

Contemporary cushioned seating with a slim profile.

- Chrome accents.
- Waterfall seat reduces pressure on the back of the knees for improved circulation.
- Padded arm caps for comfort and support.
- Can be assembled with or without arms — all hardware included.
- Manufacturer's limited five-year warranty.
- Meets or Exceeds ANSI/BIFMA Standards.

ID No.	Seat/Back Color	Base Color	Shpg. Wt.	Unit	Price
--------	-----------------	------------	-----------	------	-------

### A HIGH-BACK SLIM PROFILE CHAIR

Supports up to 275 lbs.

Seat: 20.5" × 20.88". Back: 19.63" × 23.88". Overall height: 42.13" to 45.25".

#### Leather

1	ALE-NR4119	Black/Black	Chrome	49 lbs.	Each	<del>620.00</del>
2	ALE-NR4159	Camel/Camel	Chrome	45 lbs.	Each	<del>620.00</del>
3	ALE-NR4139	Red/Red	Chrome	45 lbs.	Each	<del>620.00</del>

**Stain-Resistant Upholstery**—Treated faux leather wipes clean for a perfect white.

4	ALE-NR4106	White/White	Chrome	49 lbs.	Each	<del>620.00</del>
---	------------	-------------	--------	---------	------	-------------------

### B MID-BACK SLIM PROFILE CHAIR

Supports up to 275 lbs.

Seat: 18.88" × 20.5". Back: 19.5 × 19.75". Overall height: 28.25" to 42.13".

**Leather Seat & Back**—Leather Seat & Back

5	ALE-NR4219	Black/Black	Chrome	48 lbs.	Each	<del>500.00</del>
6	ALE-NR4259	Camel/Camel	Chrome	48 lbs.	Each	<del>500.00</del>
7	ALE-NR4239	Red/Red	Chrome	46 lbs.	Each	<del>500.00</del>

**Stain-Resistant Upholstery**—Treated faux leather wipes clean for a perfect white.

8	ALE-NR4206	White/White	Chrome	46 lbs.	Each	<del>500.00</del>
---	------------	-------------	--------	---------	------	-------------------

For more information on additional chair features see page 80.



Pneumatic Seat Height Adjustment



Tilt Tension/Tilt Lock





**A**

Black Steel Chair Frame

Black Leather (19)



Mesh-Back Chair



**B**

Red Leather (39)



**C**

Black Leather (19)

### Neratoli® Series

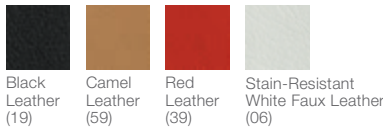

### Slimline Series

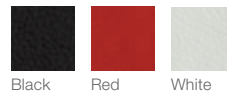

**D**

White



## Alera® Neratoli® Series

Contemporary cushioned seating with a slim profile.

- Chrome accents.
- Waterfall seat reduces pressure on the back of the knees for improved circulation.
- Padded arm caps for comfort and support.
- Can be assembled with or without arms — all hardware included.
- Manufacturer's limited five-year warranty.
- Meets or Exceeds ANSI/BIFMA Standards.

ID No.	Seat/Back Color	Base Color	Shpg. Wt.	Unit	Price
--------	-----------------	------------	-----------	------	-------

### **A** MID-BACK SLIM PROFILE CHAIR

Supports up to 275 lbs.  
Seat: 18.88" × 20.5". Back: 19.5" × 19.75". Overall height: 28.25" to 42.13".

**Leather Seat & Mesh Back**—Leather Seat & Mesh Back

1	ALE-NR4218	Black/Black	Chrome	42 lbs.	Each	<del>610.00</del>
---	------------	-------------	--------	---------	------	-------------------

**Leather Seat & Back**—Leather Seat & Back

2	ALE-NR42B19	Black/Black	Black	48 lbs.	Each	<del>560.00</del>
---	-------------	-------------	-------	---------	------	-------------------

### **B** LOW-BACK SLIM PROFILE CHAIR

Supports up to 275 lbs.  
Seat: 20.5" × 17.38". Back: 19.63" × 15.25". Overall height: 34.25" to 38.13".

**Leather**

3	ALE-NR4719	Black/Black	Chrome	43 lbs.	Each	<del>495.00</del>
---	------------	-------------	--------	---------	------	-------------------

4	ALE-NR4759	Camel/Camel	Chrome	42 lbs.	Each	<del>495.00</del>
---	------------	-------------	--------	---------	------	-------------------

5	ALE-NR4739	Red/Red	Chrome	42 lbs.	Each	<del>495.00</del>
---	------------	---------	--------	---------	------	-------------------

**Stain-Resistant Upholstery**—Treated faux leather wipes clean for a perfect white.

6	ALE-NR4706	White/White	Chrome	44 lbs.	Each	<del>495.00</del>
---	------------	-------------	--------	---------	------	-------------------

### **C** SLIM PROFILE GUEST CHAIR

Supports up to 275 lbs.  
Seat: 20.63" × 21.25". Back: 20.13" × 23.25". Overall height: 37".

7	ALE-NR4319	Black/Black	Chrome	39 lbs.	Each	<del>385.00</del>
---	------------	-------------	--------	---------	------	-------------------

\* ALE-NR42B19—Contains 5% post-consumer recycled content, 30% total recycled content.

## Alera® NT Slimline Series

Slim profile task chair with tufted cushions for all-day comfort.

- Comfortable adjustment features to control height, tilt and tilt tension.
- Tilt lock can secure the chair upright to ensure ideal back posture.
- Easily pushes into your desk when not in-use.
- Chrome base provides stability, mobility and style.
- Manufacturer's limited five-year warranty.
- Contains 5% post-consumer recycled content, 30% total recycled content.
- Meets or Exceeds ANSI/BIFMA Standards.

ID No.	Seat/Back Color	Base Color	Shpg. Wt.	Unit	Price
--------	-----------------	------------	-----------	------	-------

### **D** SLIMLINE SWIVEL/TILT TASK CHAIR

Supports up to 275 lbs.  
Seat: 20.5" × 19.5". Back: 19.88" × 23.5". Overall height: 36.38" to 40.38".

8	ALE-NT4916	Black/Black	Chrome	37 lbs.	Each	<del>499.00</del>
---	------------	-------------	--------	---------	------	-------------------

9	ALE-NT4936	Red/Red	Chrome	36 lbs.	Each	<del>499.00</del>
---	------------	---------	--------	---------	------	-------------------

**Stain-Resistant White Upholstery**—Stain-Resistant White Upholstery

10	ALE-NT4906	White/White	Chrome	36 lbs.	Each	<del>499.00</del>
----	------------	-------------	--------	---------	------	-------------------

For more information on additional chair features see page 80.



Pneumatic Seat Height Adjustment



Tilt Tension/Tilt Lock

# Seating Leather and Vinyl

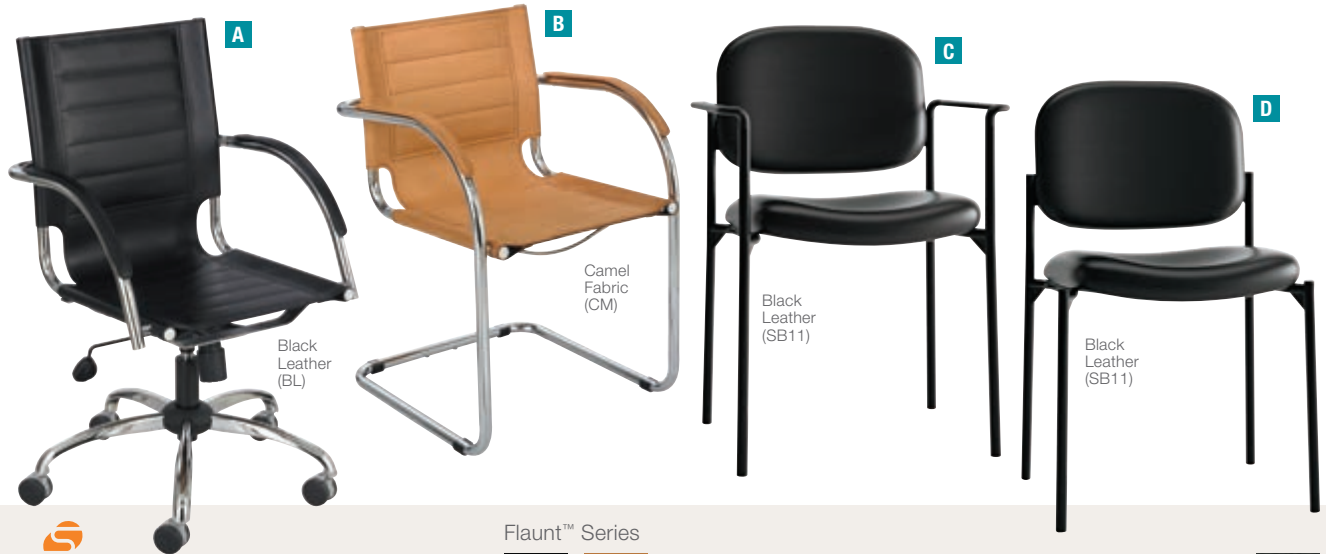

**SAFCO**  
**Flaunt™ Series**

Black Leather (BL)      Camel Fabric (CM)

Stitched accents on the seat and back for a contemporary look.

- Chrome metal frame accents the chair.
- Manufacturer's limited lifetime warranty.
- Fabric arms match the chair.

ID No.	Seat/Back Color	Base Color	Shpg. Wt.	Unit	Price
--------	-----------------	------------	-----------	------	-------

**A MID-BACK MANAGER'S CHAIR**

Five-star base with casters for easy mobility. Height-adjustable chair with swivel-tilt mechanism that may help support additional movement throughout the workday. Supports up to 250 lbs.  
 Seat: 18" x 17". Back: 18" x 20". Overall height: 37" to 40".

**Leather**

1	SAF-3456BL	Black	Chrome	36 lbs.	Each	<del>517.00</del>
---	------------	-------	--------	---------	------	-------------------

**Fabric**

2	SAF-3456CM	Camel	Chrome	36 lbs.	Each	<del>517.00</del>
---	------------	-------	--------	---------	------	-------------------

**B GUEST CHAIR**

Sturdy steel cantilevered base. Supports up to 250 lbs.  
 Seat: 18" x 17". Back: 18" x 15½". Overall height: 31¾".

**Leather**

3	SAF-3457BL	Black	Chrome	24 lbs.	Each	<del>399.00</del>
---	------------	-------	--------	---------	------	-------------------

**Fabric**

4	SAF-3457CM	Camel	Chrome	24 lbs.	Each	<del>399.00</del>
---	------------	-------	--------	---------	------	-------------------

Flaunt™ Series



**HON**  
**Scatter™ Guest Chairs**

Discover excellence without expense.

- Contoured seat and back provide ergonomic support and comfort.
- Tubular steel frame stands up to frequent handling.
- Stacks up to four high for quick and easy rearrangement in multipurpose or common areas.
- Backed by the HON Limited Five-Year Warranty.

ID No.	Seat/Back Color	Base Color	Shpg. Wt.	Unit	Price
--------	-----------------	------------	-----------	------	-------

**C SCATTER™ STACKING GUEST CHAIR WITH ARMS**

Arms promote relaxed sitting. Supports up to 250 lbs.  
 Seat: 19" x 17½". Back: 18½" x 14¾". Overall height: 32¾".

**SofThread™ Leather**

8	BSX-VL616SB11	Black	Black	18 lbs.	Each	<del>194.00</del>
---	---------------	-------	-------	---------	------	-------------------

**D SCATTER™ STACKING GUEST CHAIR WITHOUT ARMS**

Supports up to 250 lbs. Seat: 19" x 17½". Back: 18½" x 14¾". Overall height: 32¾".

**SofThread™ Leather**

9	BSX-VL606SB11	Black	Black	16 lbs.	Each	<del>176.00</del>
---	---------------	-------	-------	---------	------	-------------------

For more information on additional chair features see page 80.



Lightweight yet durable



**DURAMAT® MODERATE USE CHAIR MAT FOR LOW PILE CARPETING**

ID No.	Surface	Style	Overall (W x L)	Lip (W x L)	Unit	Price
--------	---------	-------	-----------------	-------------	------	-------

**Flat Packed**

5	DEF-CM13113	Low Pile	Lipped	36" x 48"	19" x 10"	Each <del>79.00</del>
6	DEF-CM13233	Low Pile	Lipped	45" x 53"	25" x 12"	Each <del>91.00</del>
7	DEF-CM13443F	Low Pile	Rectangular	46" x 60"	No Lip	Each <del>124.00</del>

Let your floors shine



**ECONOMAT® NON-STUDDED ALL DAY USE CHAIR MAT FOR HARD FLOORS**

ID No.	Surface	Style	Overall (W x L)	Lip (W x L)	Unit	Price
--------	---------	-------	-----------------	-------------	------	-------

**Flat Packed**

10	DEF-CM21112	Hard Floor	Lipped	36" x 48"	19" x 10"	Each <del>81.00</del>
11	DEF-CM21232	Hard Floor	Lipped	45" x 53"	25" x 12"	Each <del>99.00</del>
12	DEF-CM21442F	Hard Floor	Rectangular	46" x 60"	No Lip	Each <del>120.00</del>

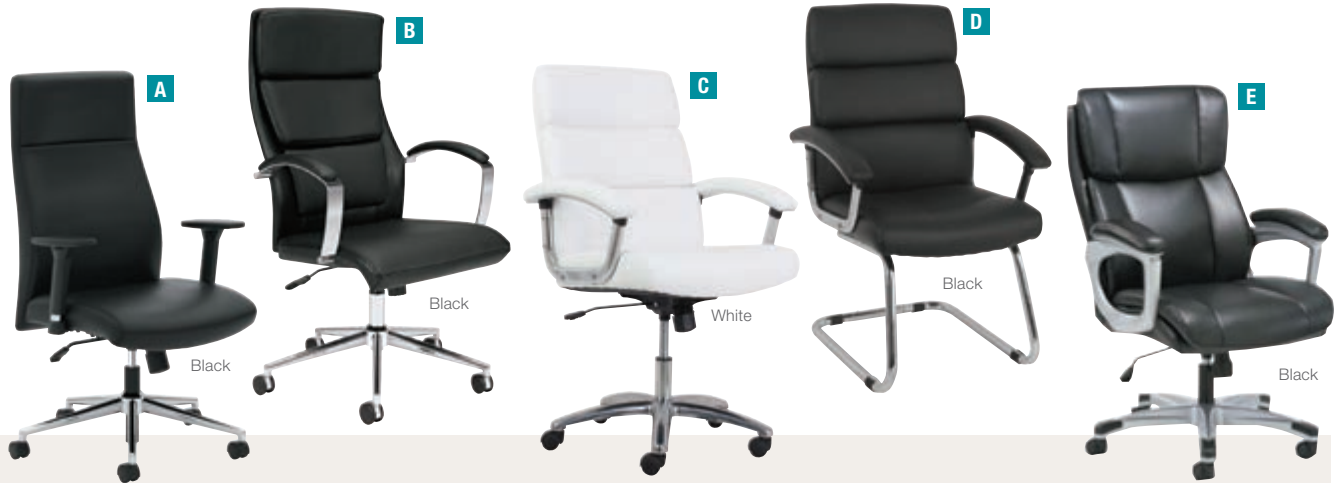

Black Leather (SB11)    White Leather (SB06)

## Traction™ SofThread™ Leather Executive & Guest Chairs

Gain control over your own comfort and give your guests a higher level of ergonomic support with HON® Traction™ modern executive and guest seating.

- The coordinated collection combines padded seats and arms for plush comfort, chrome accents and a choice of SofThread™ leather colors to create more options for matching any existing aesthetic.
- Backed by the HON Limited Five-Year Warranty.
- Meets or Exceeds ISTA Performance Standards.

## HON Define™ Executive Chairs

Tuxedo design on the back creates a contemporary aesthetic.

- Polished chrome base and arm accents reflect a professional appearance.
- The simple, understandable controls include seat and arm height to fit your body, and 2-to-1 synchro-tilt to provide comfort.
- Layers of multi-density foam in seat and back provide long-lasting comfort.
- Backed by the HON Limited Five-Year Warranty.
- Meets or Exceeds ISTA Performance Standards.

ID No.	Seat/Back Color	Base Color	Shpg. Wt.	Unit	Price
<b>A EXECUTIVE HIGH-BACK LEATHER CHAIR</b>					
Supports up to 250 lbs. Seat: 21" × 18". Back: 20" × 27". Overall height: 47". ① ④					
<b>SofThread™ Leather</b>					
1	BSX-VL108SB11	Black/Black	Polished Chrome	48 lbs.	Each <del>545.00</del>

## HVL105 Executive Chairs

Sleek European styling and polished accents deliver sophistication, style and support.

- Luxurious and comfortable leather upholstery.
- Contemporary chrome five-star base with casters for easy mobility.
- Comfortable padded leather wrapped armrests.
- Backed by the HON Limited Five-Year Warranty.

ID No.	Seat/Back Color	Base Color	Shpg. Wt.	Unit	Price
<b>B VL105 EXECUTIVE HIGH-BACK LEATHER CHAIR</b>					
Supports up to 250 lbs. Seat: 20.5" × 20.25". Back: 20.5" × 28.75". Overall height: 43" to 45.75". ① ④					
<b>SofThread™ Leather</b>					
2	BSX-VL105SB11	Black/Black	Polished Aluminum	46 lbs.	Each <del>492.00</del>



For more information on additional chair features see page 80.

ID No.	Seat/Back Color	Base Color	Shpg. Wt.	Unit	Price
<b>C TRACTION™ HIGH-BACK EXECUTIVE CHAIR</b>					
Easy to reach, simple to understand controls with two levers and a front-access tilt-tension knob. 360-degree swivel. Polished aluminum frame and five-star base. Supports up to 250 lbs. Seat: 19.5" × 19". Back: 19.25" × 24.88". Overall height: 33.75" to 37.75". ① ④					
3	BSX-VL103SB11	Black/Black	Polished Aluminum	36 lbs.	Each <del>424.00</del>
4	HON-VL103SB42	Red/Red	Polished Aluminum	38 lbs.	Each <del>424.00</del>
5	HON-VL103SB06	White/White	Polished Aluminum	38 lbs.	Each <del>424.00</del>
<b>D TRACTION™ GUEST CHAIR</b>					
Polished aluminum, cantilever frame with padded arms and a segmented seat and back. Supports up to 250 lbs. Seat: 19.7" × 18.1". Back: 18.9" × 24.6". Overall height: 26.3" to 39.3".					
6	HON-VL102SB11	Black/Black	Chrome	37 lbs.	Each <del>340.00</del>



## 3-Fifteen Executive Chair

Brings executive styling and exceptional comfort into any space within your office.

- Plush cushions offer extra padding on the seat, back and arms, which are covered in smooth SofThread leather for an upscale look.
- Easily adjust the seat height to fit your preference, and relax comfortably when reclining thanks to the tilt control mechanism.
- Move anywhere in your work space with 360-swivel and durable casters.
- Sadie™ Limited Three-Year Warranty.
- Meets or Exceeds ISTA Performance Standards. 📦 📄

ID No.	Seat/Back Color	Base Color	Shpg. Wt.	Unit	Price
<b>E HIGH-BACK EXECUTIVE CHAIR</b>					
Supports up to 225 lbs. Seat: 19.29" × 18.7". Back: 20.87" × 23.6". Overall height: 43.11" to 47.83". ① ④ ⑬					
7	BSX-VST315	Black/Black	Aluminum	44 lbs.	Each <del>258.00</del>

Prices subject to change without notice. Visit our website for the latest pricing and product information.

# Seating Leather and Vinyl



**Sadie**

## 5-Eleven Executive Chair

Add a sophisticated look to any work environment.

- Sculpted chrome arms provide comfy all-day support for upper body and shoulders.
- Fully adjustable seat height and seat back recline are designed to match your comfort and work preferences.
- Swivel-tilt control allows movement in any direction and a natural reclining position.
- Durable casters on the five-star base provide freedom of movement throughout your workspace.
- Sadie™ Limited Three-Year Warranty.
- Meets or Exceeds ISTA Performance Standards.

ID No.	Seat/Back Color	Base Color	Shpg. Wt.	Unit	Price	
<b>A MID-BACK EXECUTIVE CHAIR</b>						
Supports up to 250 lbs.						
Seat: 19" × 18.1". Back: 19.3" × 22.8". Overall height: 37.8" to 40.7".						
1	BSX-VST511	Black/Black	Aluminum	39 lbs.	Each	<del>245.00</del>

## 3-Thirty-One Executive Chair

Offers luxurious comfort and support.

- SofThread leather adds to upscale look and feel.
- Engineered for performance, with features that include height adjustable padded arms and a multi-adjustable asynchronous control.
- Features adjustable lumbar support system for additional support.
- Sadie™ Limited Three-Year Warranty.

ID No.	Seat/Back Color	Base Color	Shpg. Wt.	Unit	Price	
<b>B HIGH-BACK EXECUTIVE CHAIR</b>						
Supports up to 225 lbs.						
Seat: 21" × 17". Back: 20" × 25". Overall height: 45.28".						
2	BSX-VST331	Black/Black	Black	51 lbs.	Each	<del>345.00</del>

## 3-Oh-Five Executive Chair

Features sofThread leather for an upscale look and feel, making it a smart and stylish solution for any application.

- Offers simple and intuitive controls such as pneumatic seat height adjustment, 360-degree swivel, tilt tension and tilt lock for added customizability and comfort.
- Contemporary tapered arms add to its modern appeal.
- The comfort, stylish look, and price point of this chair make it a perfect addition to the office whether at work or at home.
- Sadie™ Limited Three-Year Warranty.
- Meets or Exceeds ISTA Performance Standards.

ID No.	Seat/Back Color	Base Color	Shpg. Wt.	Unit	Price	
<b>C MID-BACK EXECUTIVE CHAIR</b>						
Supports up to 250 lbs.						
Seat: 20" × 17". Back: 20" × 20.25". Overall height: 37.8" to 43".						
3	BSX-VST305	Black/Black	Black	33 lbs.	Each	<del>246.00</del>

**HON.**

## HVL402 Executive Chairs

Discover excellence without expense.

- Generously proportioned seat and back cushions are friendly and welcoming to every body.
- Swivel/tilt allows the chair to recline effortlessly, promoting movement and comfort throughout the day.
- Fixed padded armrests and integrated headrest provide comfort and support.
- Vinyl seat and back with contrasting stitching.
- Backed by the HON Limited Five-Year Warranty.

ID No.	Seat/Back Color	Base Color	Shpg. Wt.	Unit	Price	
<b>D EXECUTIVE HIGH-BACK CHAIR</b>						
Supports up to 250 lbs.						
Seat: 19.5" × 17.5". Back: 19" × 24.5". Overall height: 41.5" to 46".						
4	BSX-VL402EN11	Black/Black	Black	44 lbs.	Each	<del>414.00</del>
5	BSX-VL402EN45	Brown/Brown	Black	44 lbs.	Each	<del>414.00</del>

## HVL131 Executive Chairs

Plush vinyl upholstery with distinctive contrasting top stitching.

- Black vinyl upholstery is durable and easy to clean.
- Supportive padded loop arms.
- Five-star base with casters for easy mobility.
- Backed by the HON Limited Five-Year Warranty.

ID No.	Seat/Back Color	Base Color	Shpg. Wt.	Unit	Price	
<b>E EXECUTIVE HIGH-BACK CHAIR</b>						
Supports up to 250 lbs.						
Seat: 20.75" × 18.25". Back: 20.75" × 26.88". Overall height: 42" to 45.5".						
6	BSX-VL131EN11	Black/Black	Black	42 lbs.	Each	<del>431.00</del>

## Charge™ Series

Pleated stitching details provide a professional look.

- Curved arms deliver pressure-point relief.
- Strong steel frame ensures long-lasting durability.
- Luxurious leather upholstery provides the utmost professional appearance.
- Backed by the HON Limited Five-Year Warranty.

ID No.	Seat/Back Color	Base Color	Shpg. Wt.	Unit	Price	
<b>F GUEST CHAIR</b>						
Supports up to 250 lbs.						
Seat: 19" × 19.5". Back: 21.25" × 18". Overall height: 35.25".						
<b>SofThread™ Leather</b>						
7	BSX-VL643SB11	Black/Black	Black	36 lbs.	Each	<del>320.00</del>



For more information on additional chair features see page 80.





## HON Validate™ Series

Seat and back cushions feature multi-density layered foam for comfort and support.

- Waterfall seat edge promotes better leg circulation.
- Fixed arms provide support when you need it.
- Backed by the HON Limited Five-Year Warranty.
- Meets or Exceeds ISTA Performance Standards.

ID No.	Seat/Back Color	Base Color	Shpg. Wt.	Unit	Price
--------	-----------------	------------	-----------	------	-------

### A HIGH-BACK EXECUTIVE CHAIR

Discover excellence without expense. Chair features seat height and center-tilt controls as well as contemporary tapered loop arms and an integrated headrest. Supports up to 250 lbs.

Seat: 19.75" × 18.25". Back: 20" × 26.5". Overall height: 42" to 47".

#### SofThread™ Leather

1	BSX-VL604SB11	Black/Black	Black	40 lbs.	Each	<del>272.00</del>
---	---------------	-------------	-------	---------	------	-------------------

### B GUEST CHAIR

Contemporary rectilinear steel frame for added strength and durability. Supports up to 250 lbs.

Seat: 18.5" × 17.5". Back: 18.5" × 17.75". Overall height: 35".

#### SofThread™ Leather

2	BSX-VL605SB11	Black/Black	Black	23 lbs.	Each	<del>261.00</del>
---	---------------	-------------	-------	---------	------	-------------------

## HVL601 High-Back Executive Chairs

Your office workhorse goes everywhere—from the conference room to the corner office.

- Adjustable seat height accommodates nearly any user.
- Easy-care leather helps maintain a neat appearance.
- Sturdy textured frame ensures strength and stability.
- Tailored stitching detail on the seat and back elevates the overall aesthetic.
- Backed by the HON Limited Five-Year Warranty.

ID No.	Seat/Back Color	Base Color	Shpg. Wt.	Unit	Price
--------	-----------------	------------	-----------	------	-------

### C EXECUTIVE HIGH-BACK LEATHER CHAIR

Supports up to 250 lbs.

Seat: 20.5" × 17". Back: 20.5" × 26.5". Overall height: 39.5" to 44".

#### SofThread™ Leather

3	BSX-VL601SB11	Black/Black	Black	38 lbs.	Each	<del>304.00</del>
---	---------------	-------------	-------	---------	------	-------------------

For more information on additional chair features see page 80.



Black Leather (SB11)



Black Leather (SB11)

## Executive Leather Seating

Distinctive style you crave, at a fraction of the cost.

- Black SofThread™ leather upholstery for luxurious comfort and style.
- Center-tilt mechanism rotates the seat from a point at the center to comfortably recline.
- Frame and five-star base are molded from reinforced resin for increased durability.
- Backed by the HON Limited Five-Year Warranty.

ID No.	Seat/Back Color	Base Color	Shpg. Wt.	Unit	Price
--------	-----------------	------------	-----------	------	-------

### D VL151 EXECUTIVE HIGH-BACK LEATHER CHAIR

Plush, overstuffed back and padded loop arms. Supports up to 250 lbs.

Seat: 20.5" × 18.63". Back: 20.5" × 27.25". Overall height: 41.75" to 45.5".

#### Leather

4	BSX-VL151SB11	Black/Black	Black	38 lbs.	Each	<del>372.00</del>
---	---------------	-------------	-------	---------	------	-------------------

### E VL161 EXECUTIVE HIGH-BACK LEATHER CHAIR

Contemporary padded back styling. Supportive padded loop arms. Supports up to 250 lbs.

Seat: 19" × 18.75". Back: 19" × 26.38". Overall height: 41.25" to 45".

#### Leather

5	BSX-VL161SB11	Black/Black	Black	35 lbs.	Each	<del>349.00</del>
---	---------------	-------------	-------	---------	------	-------------------

### F VL171 EXECUTIVE MID-BACK LEATHER CHAIR

Scaled for smaller users and work spaces. Practicality and professionalism combined.

Supports up to 250 lbs.

Seat: 19.38" × 17.75". Back: 18.75" × 21.75". Overall height: 35" to 38.75".

#### Leather

6	BSX-VL171SB11	Black/Black	Black	26 lbs.	Each	<del>289.00</del>
---	---------------	-------------	-------	---------	------	-------------------

## HVL653 Guest Chairs

Pleated stitching detail adds a touch of class.

- SofThread™ leather and tailored stitching give this chair an upscale feel.
- Padded arms enhance comfort.
- Ideally suited for any waiting room or as guest seating in a private office.
- Backed by the HON Limited Five-Year Warranty.

ID No.	Seat/Back Color	Base Color	Shpg. Wt.	Unit	Price
--------	-----------------	------------	-----------	------	-------

### G GUEST CHAIR

Supports up to 250 lbs. Seat: 20.25" × 17". Back: 18.5" × 12". Overall height: 32".

#### SofThread™ Leather

7	BSX-VL653SB11	Black/Black	Black	28 lbs.	Each	<del>241.00</del>
---	---------------	-------------	-------	---------	------	-------------------

Prices subject to change without notice.

Visit our website for the latest pricing and product information.

# Seating Mesh



Shown with an alternate materials. Contact us for details.

## SEAT SUSPENSION

Inside the Nucleus seat, we pull stretchy NRAM banding over a frame, then mold it over with foam. Once upholstered, this ultra-slim seat provides suspended, supportive comfort.

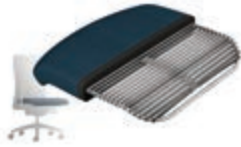

## PRESSURE MAPPING

When you sit in a Nucleus chair, the seat distributes your weight evenly, minimizing pressure points (red zones) for improved circulation and reduced muscle fatigue.

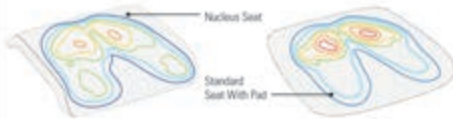

## 4-WAY STRETCH MESH BACK

A unique mesh material that moves in four directions to provide responsive, multi-directional support for your lumbar. The soft nature of the ilira-stretch envelopes you in hammock-like comfort, while providing the right level of support throughout the day.

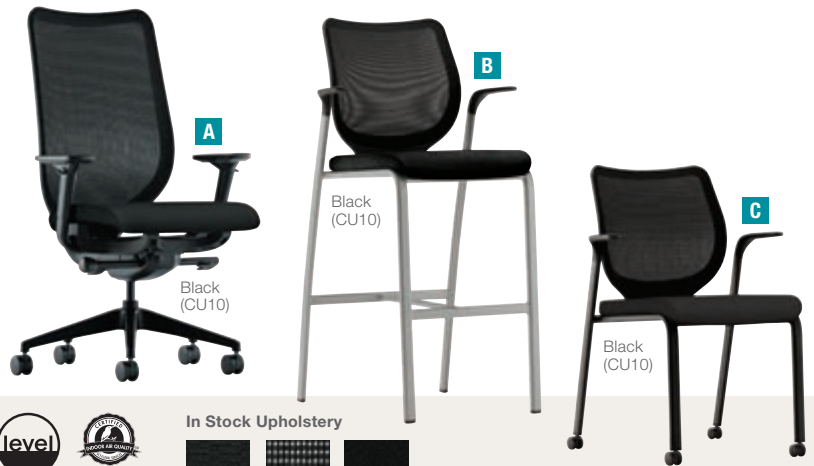
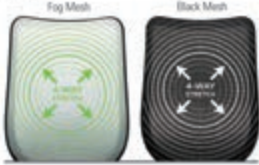

**HON.**

## Nucleus® Series Seating

Comfort from the inside out.

- Slender, contemporary look coordinates well with all office environments.
- Unique materials and innovative construction deliver surprising comfort without bulky padding.
- Multidirectional 4-Way stretch mesh back puts lumbar support right where you need it.
- Stack up to four high for space-saving storage.
- Ideal for sit-to-stand applications, cafes and common areas.
- Backed by the HON Full Lifetime Warranty.
- Contains 5% pre-consumer recycled content, 50% post-consumer recycled content.
- Level 2 Certified; Meets or exceeds ANSI/BIFMA and ISTA Performance Standards; SCS Indoor Advantage Gold Certified.



### In Stock Upholstery

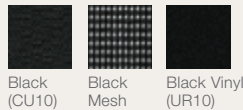

### Special Order Upholstery

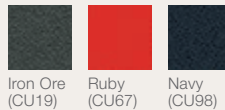

Requires additional lead time and cannot be returned.

**\*IMPORTANT:** When ordering special order items, add the finish code to the model number. Codes vary in length and placement. Example: ABC-12345AB

ID No.	Seat/Back Color	Base Color	Shpg. Wt.	Unit	Price
<b>A TASK CHAIR</b>					
Height- and width-adjustable arms for custom comfort. Five-star base with casters for easy mobility. Supports up to 300 lbs. Seat: 20" x 19". Back: 19¼" x 25¼". Overall height: 41¼" to 44¾". (1) (3) (4)					
1	HON-N103CU10	Black/Black Mesh	Black	52 lbs.	Each 991.00
2	HON-N103_* (Special Order)	(Special Order)/Black Mesh	Black	52 lbs.	Each 991.00
<b>B CAFÉ-HEIGHT STOOL</b>					
Protective glides help prevent scratches. Supports up to 300 lbs. Seat: 19" x 25". Back: 18" x 19". Overall height: 47".					
3	HON-N709CU10T1	Black/Black Mesh	Platinum	40 lbs.	Each 601.00

ID No.	Seat/Back Color	Base Color	Shpg. Wt.	Qty.	Unit	Price
--------	-----------------	------------	-----------	------	------	-------

### C MULTIPURPOSE STACKING CHAIR

Easily mobile on four swivel casters. Stack up to four high for space-saving storage. Supports up to 300 lbs. Seat: 19" x 19". Back: 18" x 18". Overall height: 37.13".

#### Black Frame

4	HON-N606HCU10	Black/Black Mesh	Black	31 lbs.	1	Each 555.00
5	HON-N606H_* (Special Order)	(Special Order)/Black Mesh	Black	31 lbs.	1	Each 536.00

#### Platinum Metallic

6	HON-N606HCU10T1	Black/Black Mesh	Platinum	31 lbs.	1	Each 555.00
7	HON-N606H_*T1 (Special Order)	(Special Order)/Black Mesh	Platinum	31 lbs.	1	Each 536.00



For more information on additional chair features see page 80.

## Ergohuman Elite



Black

Black/  
Black

B

Black/  
Black

## Hawk Chair



Black  
(BK)

Blue/Gray  
Frame  
(BE)

Burgundy/  
Gray Frame  
(BY)

C

Black/  
Black

## Apollo



Black  
(BK)

Silver  
(SR)

D

Silver/  
Silver

E

Black/  
Black



## Ergohuman Elite

All of our Ergo chairs were engineered with your total comfort in mind.

- Aesthetics, form and function are merged seamlessly in a single design, and allows the Ergo chairs to be minutely adjusted to achieve ergonomic fine tuning.
- Fine tune your Ergo with ease, using a single lever for seat depth and height, back angle, and tilt lock.
- Manufacturer's limited ten-year warranty.
- Contains 5% post-consumer recycled content, 10% total recycled content.
- Greenguard Certified; Meets or Exceeds ANSI/BIFMA Standards.

ID No.	Seat/Back Color	Base Color	Shpg. Wt.	Unit	Price
<b>A HIGH-BACK CHAIR</b>					
Seat: 19.9" × 19.3". Back: 20.7" × 22". Overall height: 39.4" to 44.9".					
1	EUT-ME22ERGLTN15	Black/Black	Black	76 lbs.	Each 1,450.00
<b>B MID-BACK MESH CHAIR</b>					
Supports up to 250 lbs. Seat: 19.88" × 19.29". Back: 20.67" × 22.44". Overall height: 39.37" to 44.69".					
2	EUT-ME5ERGLTN15	Black/Black	Black	62 lbs.	Each 1,430.00



### Single Lever Adjustment

Fine tune your Ergo with ease, using a single lever for seat depth and height, back angle and tilt lock.



### Tilt Tension Control

The tilt tension knob allows for easy adjustment of back recline resistance. Back angle can be locked in five positions (four different positions of recline or upright).



### Aluminum Frame

The Ergo sports an all-aluminum frame with chrome finish for lightness and uncompromised strength.

## Hawk Chair

A study in the concept that less is more, this chair complements any workspace with its understated elegance.

- This chair features a comfortable mesh back for flexibility and breathability.
- A weight activated mechanism responds to your unique individual needs to provide comfort and support throughout the entire workday.
- Manufacturer's limited ten-year warranty.
- Greenguard Certified; Meets or Exceeds ANSI/BIFMA Standards.

ID No.	Seat/Back Color	Base Color	Shpg. Wt.	Unit	Price
<b>C MESH-BACK CHAIR</b>					
Supports up to 250 lbs. Seat: 39.4" × 20.5". Back: 20.5" × 19.3". Overall height: 26.8" to 35.8".					
3	EUT-MF22BK	Black/Black	Black	36 lbs.	Each 445.50
4	EUT-MF22BE	Blue/Gray	Black	36 lbs.	Each 445.50
5	EUT-MF22BY	Burgundy/Gray	Black	36 lbs.	Each 445.50

## Apollo

A perennial favorite, combining value, comfort, adjustability and quality.

- Featuring a breathable, color coordinated mesh back that matches the comfortably contoured and padded waterfall seat.
- Tilt tension control.
- Manufacturer's limited ten-year warranty.
- Contains 5% post-consumer recycled content, 10% total recycled content.
- Greenguard Certified; Meets or Exceeds ANSI/BIFMA Standards.

ID No.	Seat/Back Color	Base Color	Shpg. Wt.	Unit	Price
<b>D MID-BACK MESH CHAIR</b>					
Seat: 20.5" × 19.3". Back: 19.5" × 20". Overall height: 35" to 38.5".					
6	EUT-MT9400BK	Black/Black	Black	54 lbs.	Each 458.00
7	EUT-MT9400SR	Silver/Silver	Silver	54 lbs.	Each 458.00
<b>E MULTI-FUNCTION MESH TASK CHAIR</b>					
Supports up to 250 lbs. Seat: 20.5" × 19.3". Back: 20.5" × 19.3". Overall height: 35.8" to 39.4".					
8	EUT-MFT945SL	Silver Fabric/ Silver Mesh	Black	54 lbs.	Each 517.00

For more information on additional chair features see page 80.

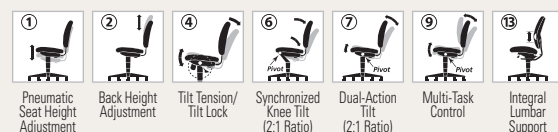



# Seating Mesh



Easy-reach seat levers for height and back adjustments.



Arms are adjustable up and down, front to back and at angles.



Easily access seat slide lever for seat depth adjustment.



A

EQ Series



Black

Black Mesh/  
Aluminum  
Base



A

Black Mesh/  
Black Base



C

K8 Series



Black

Black Mesh/  
Aluminum  
Base



B

For more information on additional chair features see page 80.

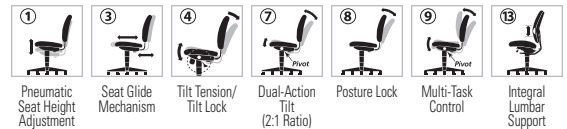

## Alera® EQ Series

A high-tech aesthetic chair with premium ergonomic features.

- Wire control synchro-tilt mechanism offers customized support.
- Breathable elastic polyester mesh seat, back and headrest.
- Waterfall seat reduces pressure at the back of your knees for improved circulation.
- Easy reach seat levers for height and back adjustment.
- Soft arms are adjustable up and down, front to back and at angles.
- Five-star base with casters for easy mobility.
- Manufacturer's limited five-year warranty.
- Meets or exceeds ANSI/BIFMA Standards.

ID No.	Seat/Back Color	Base Color	Shpg. Wt.	Unit	Price
--------	-----------------	------------	-----------	------	-------

### A ERGONOMIC MULTIFUNCTION MID-BACK MESH CHAIR

Supports up to 250 lbs. Seat: 20½" × 18½". Back: 20½" × 24½". Overall height: 37¾" to 42¾".

#### Mesh/Aluminum Base

1	ALE-EQA42ME10A	Black/Black	Aluminum	62 lbs.	Each	1,430.00
---	----------------	-------------	----------	---------	------	----------

#### Mesh/Black Base

2	ALE-EQA42ME10B	Black/Black	Black	62 lbs.	Each	1,430.00
---	----------------	-------------	-------	---------	------	----------

ID No.	Color	Unit	Price
--------	-------	------	-------

### B OPTIONAL HEADREST

Ergonomic headrest for the Alera® EQ Series. Turn any EQ Series chair into an executive high-back chair with these easy to install headrests. Headrest is height adjustable, forward or backward adjustable, and at angles for a perfect fit. Headrest includes upper back support which can function as a garment hanger. Manufacturer's limited five-year warranty. Contains 8% post-consumer recycled content, 44% total recycled content.

3	ALE-EQHR18	Black	Each	120.00
---	------------	-------	------	--------

## Alera® K8 Series

Advanced ergonomic technology combined with luxurious elegance.

- Suspension mesh provides firmness, breathability and comfort.
- High tech wire control mechanism provides easy reach access to all levers.
- Soft padded arms adjust up and down and front to back.
- Waterfall seat reduces pressure points at the back of the knee.
- Optional headrest sold and shipped separately.
- Manufacturer's limited five-year warranty.
- Meets or exceeds ANSI/BIFMA Standards.

ID No.	Seat/Back Color	Base Color	Shpg. Wt.	Unit	Price
--------	-----------------	------------	-----------	------	-------

### C ERGONOMIC MULTIFUNCTION MESH CHAIR

Supports up to 275 lbs. Seat: 19½" × 18¾". Back: 18¾" × 23¾". Overall height: 39¾" to 42¾".

4	ALE-KE4218	Black/Black	Aluminum	51 lbs.	Each	1,065.00
---	------------	-------------	----------	---------	------	----------

## Kick back

Designed with roller surface bumps to both help massage tired feet and keep your feet from slipping.

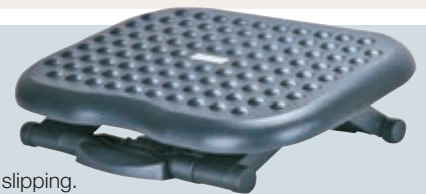

### RELAXING ADJUSTABLE FOOTREST

ID No.	W × D × H	Color	Unit	Price	
5	ALE-FS212	13¾" × 17¾" × 4½" to 6¾"	Black	Each	39.00





**A**

Multi-function chair with seat slide mechanism

Black



**Adjustable Ratchet Back**  
Make quick and easy adjustments for optimal lumbar support with the ratcheting back.



**B**

Synchro-tilt chair with seat slide

Black



Black



**C**

Mesh back and seat. Synchro-tilt chair with seat slide

Black



**D**

Swivel-tilt chair with adjustable arms

Black



**E**

Swivel-tilt chair

Black



## Alera® Elusion® II Series

Modern styling, all-day comfort, and enhanced ergonomics.

- Ergonomically designed chair frame to help support proper posture when sitting back.
- Breathable mesh back for all-day cool comfort.
- Height-adjustable ratchet back for optimal lumbar support.
- Manufacturer's limited five-year warranty.
- Contains 5% post-consumer recycled content, 30% total recycled content.
- Meets or exceeds ANSI/BIFMA Standards. ♻️ ♻️ ♻️

ID No.	Seat/Back Color	Base Color	Shpg. Wt.	Unit	Price
<b>A MID-BACK MULTI-FUNCTION WITH SEAT SLIDE CHAIR</b>					
Supports up to 275 lbs. Seat: 22" x 20 7/8". Back: 20 1/4" x 22". Overall height: 40 3/8" to 43 1/4". ① ② ③ ④ ⑩					
1	ALE-ELT4214M	Black/Black	Black	56 lbs.	Each 640.00
<b>B MID-BACK SYNCHRO WITH SEAT SLIDE CHAIR</b>					
Supports up to 275 lbs. Seat: 22" x 20 7/8". Back: 20 1/4" x 22 5/8". Overall height: 39 1/2" to 45 1/4". ① ② ③ ④ ⑨ ⑫					
2	ALE-ELT4214S	Black/Black	Black	48 lbs.	Each 500.00
<b>C MID-BACK SYNCHRO WITH SEAT SLIDE CHAIR</b>					
Supports up to 275 lbs. Seat: 20 7/8" x 20". Back: 20 1/4" x 22". Overall height: 40" to 48 1/8". ① ② ③ ④ ⑨ ⑫					
3	ALE-ELT4218S	Black/Black	Black	48 lbs.	Each 660.00
<b>D MID-BACK SWIVEL/TILT CHAIR WITH ADJUSTABLE ARMS</b>					
Supports up to 275 lbs. Seat: 22" x 20 7/8". Back: 20 1/4" x 22 5/8". Overall height: 39 1/2" to 45 1/4". ① ② ④					
4	ALE-ELT4214F	Black/Black	Black	43 lbs.	Each 460.00
<b>E MID-BACK SWIVEL/TILT CHAIR</b>					
Supports up to 275 lbs. Seat: 20" x 20 7/8". Back: 20 1/4" x 22". Overall height: 39 1/2" to 45 1/4". ① ② ④					
5	ALE-ELT4214B	Black/Black	Black	42 lbs.	Each 425.00

Looking for Footrests or back supports?  
See pages 161–164

For more information on additional chair features see page 80.

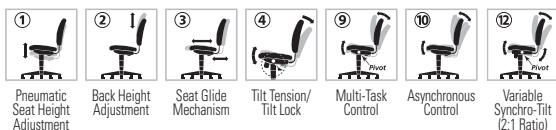

# Seating Mesh



## Alera® Elusion™ Series

Clean, classic styling complements the busy office environment.

- Contoured seat cushion with waterfall edge to help relieve pressure on legs.
- Height- and width-adjustable arms with soft polyurethane pads.
- Five-star base with casters for easy mobility.
- Breathable mesh back for all day support.
- Height adjustable ratchet back for optimal lumbar support.
- Manufacturer's limited five-year warranty.
- Meets or exceeds ANSI/BIFMA Standards.



## Elusion Nesting Chairs

Ideal for training or conference rooms, or collaborative environments.

- Flip-up nesting seat design for easy high-density storage.
- Molded foam seat for resiliency and all day comfort.
- Cool breathable mesh back upholstery.
- Four-leg metal base with casters for durability and mobility.
- Manufacturer's limited five-year warranty.
- Meets or Exceeds ANSI/BIFMA Standards.

ID No.	Seat/Back Color	Base Color	Shpg. Wt.	Unit	Price
--------	-----------------	------------	-----------	------	-------

### A MESH HIGH-BACK MULTIFUNCTION CHAIR WITH SEAT SLIDE

Supports up to 250 lbs. Seat: 20½" × 21". Back: 20½" × 24". Overall height: 41" to 46½".

#### Premium Fabric Upholstery

1	ALE-EL41ME10B	Black/Black	Black	58 lbs.	Each	525.00
---	---------------	-------------	-------	---------	------	--------

### B MESH MID-BACK MULTIFUNCTION CHAIR WITH SEAT SLIDE

Supports up to 250 lbs. Seat: 20½" × 21". Back: 20½" × 20½". Overall height: 36½" to 42½".

#### Leather Upholstery

2	ALE-EL4215	Black/Black	Black	58 lbs.	Each	505.00
---	------------	-------------	-------	---------	------	--------

#### Premium Fabric Upholstery

3	ALE-EL42ME10B	Black/Black	Black	57 lbs.	Each	485.00
---	---------------	-------------	-------	---------	------	--------

### C MESH MID-BACK SWIVEL/TILT CHAIR

Ergonomic design adjusts to fit multiple users. Supports up to 250 lbs. Seat: 21" × 20½". Back: 20½" × 20½". Overall height: 27" to 40½".

#### Air Mesh Seat Upholstery

4	ALE-EL42B18	Black/Black	Black	50 lbs.	Each	505.00
---	-------------	-------------	-------	---------	------	--------

#### Premium Fabric Upholstery

5	ALE-EL42BME10B	Black/Black	Black	48 lbs.	Each	375.00
---	----------------	-------------	-------	---------	------	--------

6	ALE-EL42B04	Black/White	Black	48 lbs.	Each	375.00
---	-------------	-------------	-------	---------	------	--------

### D MESH STOOL

Ergonomically designed stool adjusts to fit multiple users. Adjustable foot ring for leg support. Supports up to 250 lbs. Seat: 20½" × 21". Back: 20½" × 22½". Overall height: 42½" to 51½".

7	ALE-EL4614	Black/Black	Black	53 lbs.	Each	505.00
---	------------	-------------	-------	---------	------	--------

ID No.	Seat/Back Color	Base Color	Shpg. Wt.	Qty.	Unit	Price
--------	-----------------	------------	-----------	------	------	-------

### E MESH NESTING CHAIRS

Supports up to 275 lbs. Seat: 19¼" × 18¾". Back: 20" × 19¼". Overall height: 37¾".

8	ALE-EL4915	Black/Black	Black	58 lbs.	2 Carton	519.00
---	------------	-------------	-------	---------	----------	--------

### With Padded Arms

9	ALE-EL4914	Black/Black	Black	68 lbs.	2 Carton	549.00
---	------------	-------------	-------	---------	----------	--------

## Guest Stacking Chair

Coordinate mesh chair for training, conference, or waiting rooms.

- Cool breathable mesh back upholstery stacks up to five high.
- Includes both glides for fixed use and casters for mobility.
- Provides long lasting support.
- Stacks up to five high.
- Manufacturer's limited five-year warranty.
- Contains 5% post-consumer recycled content, 20% total recycled content.
- Meets or exceeds ANSI/BIFMA Standards.

ID No.	Seat/Back Color	Base Color	Shpg. Wt.	Unit	Price
--------	-----------------	------------	-----------	------	-------

### F MESH GUEST STACK CHAIR

Supports up to 250 lbs. Seat: 18¾" × 18¾". Back: 20¾" × 17¾". Overall height: 36¼".

10	ALE-EL4314	Black/Black	Black	27 lbs.	Each	305.00
----	------------	-------------	-------	---------	------	--------



For more information on additional chair features see page 80.

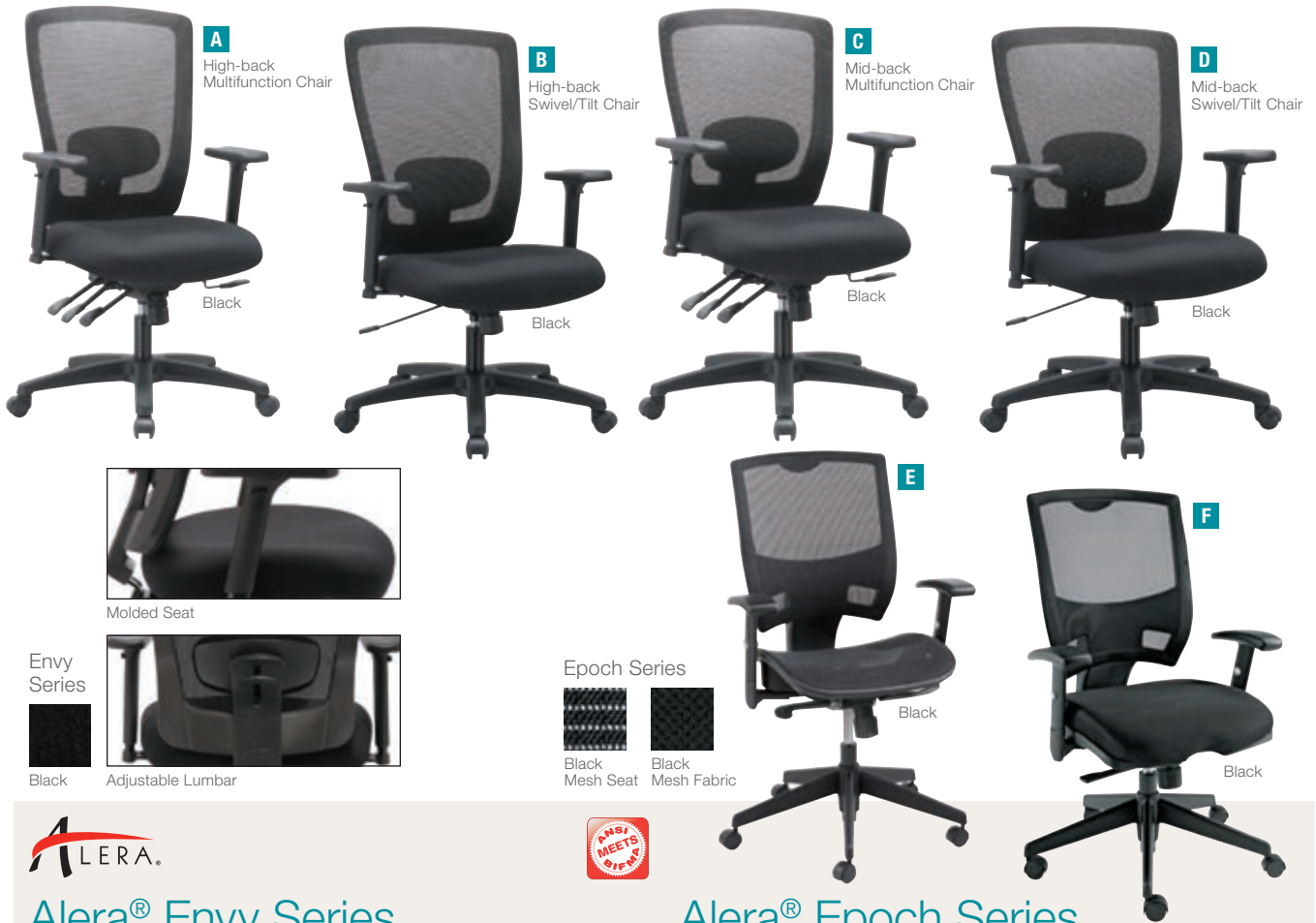

Envy Series



Black



Molded Seat



Adjustable Lumbar

Epoch Series



Black Mesh Seat



Black Mesh Fabric



## Alera® Envy Series

Crisp visual design and a variety of ergonomic adjustments at an irresistible price.

- Contoured seat cushion with waterfall edge helps relieve pressure on legs.
- Adjustable-height and -width arms move up and down, as well as toward and away from the body to adapt to various body sizes.
- Lumbar adjustment supports the lower back and can be adjusted to satisfy a variety of different users.
- Manufacturer's limited five-year warranty.
- Meets or exceeds ANSI/BIFMA Standards. ✘

ID No.	Seat/Back Color	Base Color	Shpg. Wt.	Unit	Price
--------	-----------------	------------	-----------	------	-------

### A MESH HIGH-BACK MULTIFUNCTION CHAIR

Asynchronous control offers a wide range of movement, assists in spinal alignment and distributes users weight evenly. Infinite tilt lock secures chair at nearly any reclining angle. Supports up to 250 lbs. Seat: 20" × 20½". Back: 17½" × 25". Overall height: 41¼" to 46½". ① ③ ④ ⑩ ⑬

1	ALE-NV41M14	Black/Black	Black	45 lbs.	Each	795.00
---	-------------	-------------	-------	---------	------	--------

### B MESH HIGH-BACK SWIVEL/TILT CHAIR

Upright tilt lock secures chair in full upright position for additional support. Supports up to 250 lbs. Seat: 20" × 17.75". Back: 17½" × 25". Overall height: 42¼" to 46¾". ① ④ ⑬

2	ALE-NV41B14	Black/Black	Black	45 lbs.	Each	565.00
---	-------------	-------------	-------	---------	------	--------

### C MESH MID-BACK MULTIFUNCTION CHAIR

Asynchronous control offers a wide range of movement, assists in spinal alignment and distributes users weight evenly. Infinite tilt lock secures chair at nearly any reclining angle. Supports up to 250 lbs. Seat: 20" × 20½". Back: 17½" × 22½". Overall height: 40" to 43¾". ① ③ ④ ⑩ ⑬

3	ALE-NV42M14	Black/Black	Black	45 lbs.	Each	655.00
---	-------------	-------------	-------	---------	------	--------

### D MESH MID-BACK SWIVEL/TILT CHAIR

Swivel-tilt with lock and tension control which allows users to adjust to the demands of the workday. Supports up to 250 lbs. Seat: 20.75" × 17.75". Back: 17½" × 22½". Overall height: 37" to 41½". ① ④ ⑬

4	ALE-NV42B14	Black/Black	Black	45 lbs.	Each	515.00
---	-------------	-------------	-------	---------	------	--------

## Alera® Epoch Series

Aesthetically designed for a contemporary feel.

- Mesh-covered curved back for added support.
- Five-star base with casters.
- Contoured seat for comfort.
- Multiple adjustments for each user's needs.
- Height adjustable T-bar arms.
- Ratchet back for ideal lumbar placement.
- Manufacturer's limited five-year warranty.
- Meets or exceeds ANSI/BIFMA Standards. ✘

ID No.	Seat/Back Color	Base Color	Shpg. Wt.	Unit	Price
--------	-----------------	------------	-----------	------	-------

### E SUSPENSION MESH MULTIFUNCTION CHAIR

Mesh suspension seat for cool comfort. Supports up to 275 lbs. Seat: 20.13" × 19.63". Back: 18.5" × 28.75". Overall height: 38.63" to 43.75". ① ② ④ ⑫

5	ALE-EP4218	Black/Black	Black	49 lbs.	Each	630.00
---	------------	-------------	-------	---------	------	--------

### F FABRIC MESH MULTIFUNCTION CHAIR

Cushioned fabric mesh seat adjusts back angle with a single lever. Supports up to 275 lbs. Seat: 18.88" × 18.25". Back: 18.5" × 28.75". Overall height: 39.5" to 44.75". ① ② ④ ⑫

6	ALE-EP42ME10B	Black/Black	Black	46 lbs.	Each	535.00
---	---------------	-------------	-------	---------	------	--------

For more information on additional chair features see page 80.



Prices subject to change without notice.  
Visit our website for the latest pricing and product information.

# Seating Mesh

## Etros Series

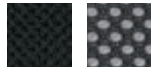

Black Fabric  
Black Mesh

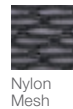

Nylon Mesh

For more information on additional chair features see page 80.

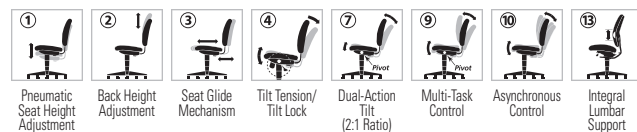

## Alera® Etros Series

An economical choice for mesh comfort.

- Breathable mesh back with cushioned mesh fabric seat.
- Adjustable lumbar support.
- Five-star base with casters for easy mobility.
- Manufacturer's limited five-year warranty.
- Contains 5% post-consumer recycled content, 30% total recycled content.
- Meets or exceeds ANSI/BIFMA Standards.

ID No.	Seat/Back Color	Base Color	Shpg. Wt.	Unit	Price
<b>A HIGH-BACK MULTIFUNCTION WITH SEAT SLIDE CHAIR</b>					
Supports up to 275 lbs. Seat: 22¾" × 20½". Back: 19¾" × 25¾". Overall height: 43¼" to 49".					
1	ALE-ET4117	Black/Black	Black	56 lbs.	Each 559.00
<b>B HIGH-BACK SWIVEL/TILT CHAIR</b>					
Supports up to 275 lbs. Seat: 21¾" × 20½". Back: 19¾" × 25¾". Overall height: 41" to 44¼".					
2	ALE-ET4117B	Black/Black	Black	42 lbs.	Each 389.00
<b>C MID-BACK MULTIFUNCTION WITH SEAT SLIDE CHAIR</b>					
Supports up to 275 lbs. Seat: 20" × 20". Back: 18¾" × 20¾". Overall height: 38" to 45½".					
3	ALE-ET4217	Black/Black	Black	53 lbs.	Each 499.00
<b>D MESH MID-BACK CHAIR</b>					
Breathable mesh back with cushioned mesh fabric seat. Supports up to 275 lbs. Seat: 20" × 20¾". Back: 18¾" × 20¾". Overall height: 36¾" to 40¾".					
4	ALE-ET42ME10B	Black/Black	Black	34 lbs.	Each 345.00
<b>E SUSPENSION MESH MID-BACK SYNCHRO TILT CHAIR</b>					
Mesh suspension seat and back provides firmness, breathability and comfort. Back reclines at 2-to-1 angle to the seat allowing user to recline while keeping seat relatively even with the floor. Supports up to 275 lbs. Seat: 20½" × 19¾". Back: 18¾" × 23¾". Overall height: 35¾" to 39¾".					
5	ALE-ET4218	Black/Black	Black	44 lbs.	Each 445.00
<b>F MESH MID-BACK PETITE MULTIFUNCTION CHAIR</b>					
Designed for the petite user, but adjustable to fit all. Three-lever multifunction mechanism for complete control of the back angle relative to seat, seat slide and forward tilt. Height- and width-adjustable arms with soft polyurethane armcaps for ideal arm placement. Tilt lock and tilt tension controls rate of recline to accommodate any user. Supports up to 275 lbs. Seat: 20½" × 17¾". Back: 18¾" × 20¾". Overall height: 36¼" to 41¾".					
6	ALE-ET4017	Black/Black	Black	52 lbs.	Each 480.00
<b>G MID-BACK PETITE SWIVEL/TILT CHAIR</b>					
Supports up to 275 lbs. Seat: 20½" × 19½". Back: 18¾" × 20¾". Overall height: 35¾" to 39¾".					
7	ALE-ET4017B	Black/Black	Black	36 lbs.	Each 309.00
<b>H HEIGHT ADJUSTABLE MESH STOOL</b>					
Height adjustable footring for optimal foot positioning. Supports up to 275 lbs. Seat: 19¾" × 19¾". Back: 18¾" × 20¾". Overall height: 44¼" to 54½".					
8	ALE-ET4614	Black/Black	Black	40 lbs.	Each 465.00





## Alera® EB Series

Advanced ergonomics combined with intelligent design fits most any user.

- Synchro function tilts back in a 2:1 ratio to the seat for a more natural reclining position.
- Breathable mesh back and generously padded seat for all-day comfort.
- Unique action pivoting arms accommodates the busy on-the-go user.
- Waterfall seat edge reduces pressure points at the back of the knee.
- Manufacturer's limited five-year warranty.
- Contains 5% post-consumer recycled content, 30% total recycled content.
- Meets or exceeds ANSI/BIFMA Standards.

ID No.	Seat/Back Color	Base Color	Shpg. Wt.	Unit	Price
--------	-----------------	------------	-----------	------	-------

### A EB-W SERIES PIVOT ARM MULTIFUNCTION MESH CHAIR

Pivoting swing arms adjust inward when leaning forward for close-in tasks or swing out to accommodate the wingspan. Arms also adjust up or down and front and back. Seat slider function adjusts seat depth to fit perfectly at the knee. Advanced micro-mesh back fabric is both comfortable and cooling with durable molded foam fabric seat for the perfect sit. Supports up to 275 lbs. Seat: 20" x 21 1/8". Back: 19 1/2" x 23 3/4". Overall height: 38 3/4" to 42 3/4".

1	ALE-EBW4213	Black/Black	Aluminum	64 lbs.	Each	895.00
---	-------------	-------------	----------	---------	------	--------

### B EB-K SERIES SYNCHRO MID-BACK FLIP-ARM MESH CHAIR

Flip-back arms neatly pivot backward and out of the way when not needed. Supports up to 275 lbs. Seat: 20 1/4" x 20 1/2". Back: 18 1/2" x 23 1/4". Overall height: 39" to 42 1/4".

2	ALE-EBK4217	Black/Black	Black	43 lbs.	Each	509.00
---	-------------	-------------	-------	---------	------	--------

### C EB-E SERIES MID-BACK SWIVEL/TILT MESH CHAIR

Flip-back arms pivot back and out of the way when not needed. Supports up to 275 lbs. Seat: 19 3/4" x 20 1/2". Back: 19 3/4" x 20 1/2". Overall height: 36 3/4" to 40 3/4".

3	ALE-EBE4217	Black/Black	Black	34 lbs.	Each	319.00
---	-------------	-------------	-------	---------	------	--------

## Alera® Eon Series

Contemporary design with cool comfort.

- Sleek and easy-to-use multifunction wire mechanism adjusts seat and back independently while providing tilt and infinite locking positions.
- Adjustable seat depth for optimal back and leg positioning.
- Manufacturer's limited five-year warranty.
- Meets or exceeds ANSI/BIFMA Standards.

ID No.	Seat/Back Color	Base Color	Shpg. Wt.	Unit	Price
--------	-----------------	------------	-----------	------	-------

### D MULTIFUNCTION MID-BACK SUSPENSION MESH CHAIR

Supports up to 275 lbs. Seat: 19.75" x 20.5". Back: 18.5" x 23.25". Overall height: 38.63" to 42.5".

4	ALE-EN4218	Black/Black	Black	57 lbs.	Each	670.00
---	------------	-------------	-------	---------	------	--------

### E MULTIFUNCTION MID-BACK CUSHIONED MESH CHAIR

Supports up to 275 lbs. Seat: 20.13" x 21.5". Back: 18.5" x 23.25". Overall height: 37.25" to 40.75".

5	ALE-EN4217	Black/Black	Black	54 lbs.	Each	630.00
---	------------	-------------	-------	---------	------	--------

### F MID-BACK LEATHER SYNCHRO WITH SEAT SLIDE CHAIR

Supports up to 275 lbs. Seat: 20.25" x 20.5". Back: 18.5" x 23.25". Overall height: 37.25" to 40.75".

6	ALE-EN4219	Black/Black	Black	57 lbs.	Each	625.00
---	------------	-------------	-------	---------	------	--------

\* Contains 5% post-consumer recycled content, 30% total recycled content.

## Alera® Neratoli® Series

Contemporary cushioned seating with a slim profile.

- Chrome accents.
- Waterfall seat reduces pressure on the back of the knees for improved circulation.
- Padded arm caps for comfort and support.
- Can be assembled with or without arms — all hardware included.
- Manufacturer's limited five-year warranty.
- Meets or exceeds ANSI/BIFMA Standards.

ID No.	Seat/Back Color	Base Color	Shpg. Wt.	Unit	Price
--------	-----------------	------------	-----------	------	-------

### G MID-BACK SLIM PROFILE CHAIR

Supports up to 275 lbs. Seat: 18 1/2" x 20 1/2". Back: 18 1/2" x 20 1/2". Overall height: 39" to 42 1/4".

7	ALE-NR4218	Black/Black	Chrome	42 lbs.	Each	610.00
---	------------	-------------	--------	---------	------	--------

For more information on additional chair features see page 80.



Prices subject to change without notice. Visit our website for the latest pricing and product information.

# Seating Mesh



Convergence® Chair shown with in alternate materials. Contact us for details.

**HON.**

## Lota® Series

Style and substance, perfectly meshed.

- Mesh back adds both a level of sophistication and comfort.
- Ships with both casters and glides.
- Backed by the HON Full Lifetime Warranty.
- Meets or exceeds ANSI/BIFMA Standards.

ID No.	Seat/Back Color	Base Color	Shpg. Wt.	Unit	Price
--------	-----------------	------------	-----------	------	-------

### A MESH MID-BACK TASK CHAIR

Ergonomically designed to adjust seat height and tilt based on user's weight and posture. Three-way adjustable arms with multiple depth, height and pivot positions. Five-star base with casters for easy mobility. Supports up to 250 lbs. Seat: 19½" × 17¼". Back: 17¾" × 23¼". Overall height: 43½".

#### With Black Base

1	HON-2281VA10T	Black/Black	Black	50 lbs.	Each	753.00
---	---------------	-------------	-------	---------	------	--------

#### With Polished Aluminum Base and Accents

2	HON-2283VA10PA	Black/Black	Polished Aluminum	53 lbs.	Each	925.00
---	----------------	-------------	-------------------	---------	------	--------

### B MESH STACKING GUEST CHAIR

Both casters and glides are packaged with the chair, to allow the chair to be converted from mobile to stationary use. Stack up to four high. Supports up to 250 lbs. Seat: 18½" × 17¾". Back: 17¾" × 17¾". Overall height: 34½".

3	HON-2285VA10	Black/Black	Black	20 lbs.	Each	392.00
---	--------------	-------------	-------	---------	------	--------



## Convergence® Chair

Black mesh back is breathable for all-day comfort and support.

- Black seat fabric flexes and stretches to make the soft foam even more responsive.
- Thick seat cushions to take the stress off the lower body throughout the day
- Lumbar support that adds a little extra lower back comfort.
- Height- and width-adjustable arms move to put the support right where you want it.
- Your choice of swivel tilt or synchro-tilt control with seat slide puts you in a posture for success.
- HON full lifetime warranty.
- Meets or Exceeds ISTA Standards.

ID No.	Seat/Back Color	Base Color	Shpg. Wt.	Unit	Price
--------	-----------------	------------	-----------	------	-------

### C MESH MID-BACK TASK CHAIR

Supports up to 275 lbs. Seat: 20" × 19". Back: 18" × 22". Overall height: 36" to 42".

#### Swivel Tilt Control

4	HON-CMS1AACCF10	Black Fabric	Black	44 lbs.	Each	330.00
5	HON-CMS1AUR10	Black Vinyl	Black	44 lbs.	Each	362.00
6	HON-CMZ1A_	(Special Order)/Black	Black	38 lbs.	Each	330.00

#### Synchro-Tilt Control with Seat Slide

7	HON-CMY1AACCF10	Black Fabric	Black	44 lbs.	Each	365.00
8	HON-CMY1AUR10	Black Vinyl	Black	44 lbs.	Each	397.00
9	HON-CMY1A_	(Special Order)/Black	Black	40 lbs.	Each	373.00

\* HON-CMZ1ACU47, HON-CMZ1ACU49, HON-CMZ1ACU19, HON-CMZ1ACU98, HON-CMZ1ACU84, HON-CMZ1ACU67—Contains 13% post-consumer recycled content, 80% total recycled content. HON-CMZ1ACU22—Level 2 Certified; SCS Indoor Advantage Gold Certified. Contains 14% post-consumer recycled content, 22% total recycled content.

### 3-Way Adjustable Arms

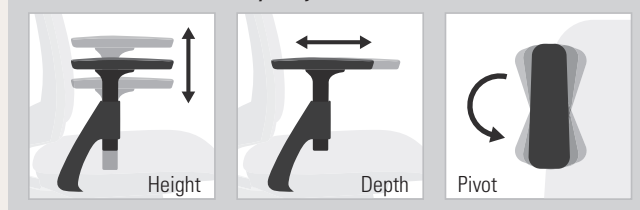

For more information on additional chair features see page 80.

#### In-Stock



#### Special Order



**\*IMPORTANT:** When ordering special order items, add the finish code to the model number. Codes vary in length and placement. Example: ABC-12345**AB**



Requires additional lead time and cannot be returned.

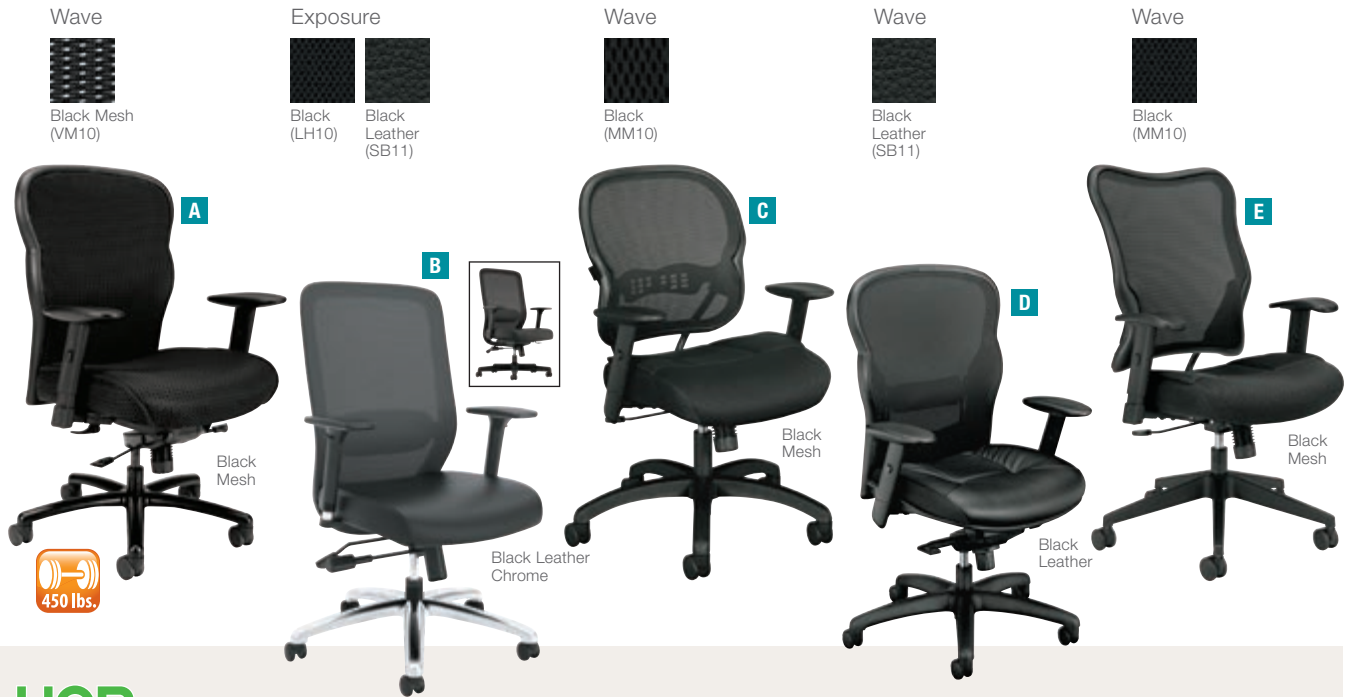

**HON.**

## Wave™ Mesh Big & Tall Chair

Provides comfort and long-lasting performance for people weighing up to 450 lbs.

- Adjustable lumbar support helps reduce back fatigue.
- Five-star base with casters for easy mobility.
- Height and width adjustable arms and tilt tension/tilt lock control for comfortable recline.
- Backed by the HON Limited Five-Year Warranty.

ID No.	Seat/Back Color	Base Color	Shpg. Wt.	Unit	Price
--------	-----------------	------------	-----------	------	-------

**A MESH BIG & TALL CHAIR**

Supports up to 450 lbs. Seat: 21¾" × 18¾". Back: 22½" × 27½". Overall height: 39¾" to 42¾".

1	BSX-VL705VM10	Black/Black	Black	59 lbs.	Each	784.00
---	---------------	-------------	-------	---------	------	--------

## Exposure™ Mesh Task Chair

Contemporary visual design and slim profile complement any modern office environment.

- Curvilinear back shape with adjustable lumbar provides total back support.
- Synchro-tilt mechanism reclines the back at a higher ratio than the seat for proper back alignment.
- Breathable mesh back conforms to the upper body for added comfort.
- Frame and five-star base are molded from fiberglass-reinforced resin for increased durability.
- Adjustments for seat height/depth, and arm height/width to fit your body.
- Seat glide adjustment moves the seat cushion forward or back to adapt to user preference.
- Seat design optimally aligns legs and hips for long-lasting comfort.
- Backed by the HON Limited Five-Year Warranty.
- Meets or exceeds ISTA Performance Standards.

ID No.	Seat/Back Color	Base Color	Shpg. Wt.	Unit	Price
--------	-----------------	------------	-----------	------	-------

**B MESH HIGH-BACK TASK CHAIR**

Supports up to 250 lbs. Seat: 19½" × 20". Back: 18½" × 25½". Overall height: 39" to 43".

**SoftThread™ Leather**—SoftThread™ leather upholstery delivers an upscale look and feel.

2	BSX-VL721SB11	Black/Black	Black	49 lbs.	Each	662.00
---	---------------	-------------	-------	---------	------	--------

**Fabric**

3	BSX-VL721LH10	Black/Black	Black	48 lbs.	Each	555.00
---	---------------	-------------	-------	---------	------	--------

## Wave™ Mesh Chair

Contemporary styling with incredible comfort and support.

- Breathable and comfortable black mesh back.
- Sturdy base ensures strength and stability.
- Five-star nylon base with casters.
- 2-to-1 synchro tilt provides a deep, comfortable recline.
- Height adjustable arms.
- Sandwich mesh seat is contoured for comfort.
- Backed by the HON Limited Five-Year Warranty.

ID No.	Seat/Back Color	Base Color	Shpg. Wt.	Unit	Price
--------	-----------------	------------	-----------	------	-------

**C MESH MID-BACK TASK CHAIR**

Supports up to 250 lbs. Seat: 19¾" × 18½". Back: 20½" × 20¾". Overall height: 37½" to 41¾".

4	BSX-VL712MM10	Black/Black	Black	39 lbs.	Each	449.00
---	---------------	-------------	-------	---------	------	--------

**D MESH HIGH-BACK TASK CHAIR - SYNCHRONIZED KNEE-TILT**

Provides a full, deep recline while keeping your feet on the floor. Adjustable lumbar support. Thickly padded seat wrapped in luxurious black SoftThread™ leather. Height-adjustable arms and highly styled mesh back. Supports up to 250 lbs. Seat: 20¾" × 20". Back: 23" × 23¾". Overall height: 41¾" to 44¾".

**Leather**

5	BSX-VL701SB11	Black/Black	Black	53 lbs.	Each	656.00
---	---------------	-------------	-------	---------	------	--------

**E MESH HIGH-BACK TASK CHAIR - SYNCHRO-TILT**

2-to-1 synchro tilt provides a deep, comfortable recline. Sandwich mesh supports up to 250 lbs. Seat cushion with two layers of padding for increased comfort. Height-adjustable arms. Supports up to 250 lbs. Seat: 21" × 20". Back: 19½" × 24". Overall height: 35½" to 40½".

6	BSX-VL702MM10	Black/Black	Black	40 lbs.	Each	532.00
---	---------------	-------------	-------	---------	------	--------

For more information on additional chair features see page 80.

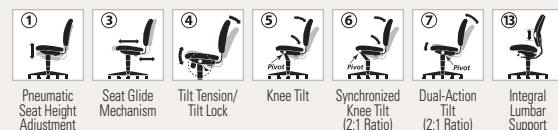

Prices subject to change without notice. Visit our website for the latest pricing and product information.



## HON.



### Quotient® Series

When form and function are perfectly divided.

- Seat cushion contours reduce pressure points to provide support exactly where needed.
- 4-way stretch mesh knit fabric back cradles spine.
- Additional support bar on back frame increases overall strength.
- Controls on this chair are easy to reach and simple to understand, featuring only one lever and front-access tilt tension.
- Synchro-tilt mechanism reclines the back at a higher ratio than the seat for proper back alignment.
- Warranted for users up to 300 lbs.
- Height- and width-adjustable arms.
- Backed by the HON Full Lifetime Warranty.
- Contains 10% post-consumer recycled content, 29% total recycled content.
- Level 2 Certified; Meets or exceeds ANSI/BIFMA Standards and ISTA Performance Standards; SCS Indoor Advantage Gold Certified.



ID No.	Seat/Back Color	Base Color	Shpg. Wt.	Unit	Price
<b>A MESH MID-BACK TASK CHAIR</b>					
Supports up to 300 lbs. Seat: 19" x 17". Back: 18" x 19". Overall height: 33" to 38".					
1	HON-QTMMY1ACU10	Black/Black	Black	43 lbs.	Each 545.00
2	HON-QTMMY1A_*	(Special Order)/Black	Black	43 lbs.	Each 545.00
<b>B MESH MID-BACK TASK STOOL</b>					
Supports up to 300 lbs. Seat: 19" x 17". Back: 18" x 19". Overall height: 39" to 49".					
3	HON-QTSMY1ACU10	Black/Black	Black	49 lbs.	Each 605.00
4	HON-QTSMY1A_*	(Special Order)/Black	Black	49 lbs.	Each 605.00



#### In-Stock Upholstery



Black (CU10)

#### Special Order Upholstery



Iron Ore (CU19)



Navy (CU98)



Ruby (CU67)



Requires additional lead time and cannot be returned.

#### Thin Profile Seat

Unlike many other chairs that require a thick cushion to offer a plush feel, Quotient features a high-density foam that delivers cushioned comfort in a slimmer profile.



For more information on additional chair features see page 80.





**Sadie**

## 1-Forty-One Big & Tall Mesh Task Chair

Offers luxurious comfort and support.

- Customizable features include an adjustable lumbar support for the lower back, height-adjustable arms and a 360-swivel seat that quickly moves up and down to fit a variety of users.
- Mesh back creates breathable support that stretches to reduce pressure points, while the cushioned fabric seat offers plush comfort all day long.
- Whether used in a workstation or a home office, this chair provides the upscale style, ergonomic support and low price that makes it an attractive option for anyone seeking a little extra structural support.
- Sadie™ Limited Three-Year Warranty.
- Meets or Exceeds ISTA Performance Standards.

ID No.	Seat/Back Color	Base Color	Shpg. Wt.	Unit	Price
<b>A 1-FORTY-ONE BIG &amp; TALL MESH TASK CHAIR</b>					
Supports up to 350 lbs. Seat: 22" × 19.8". Back: 22" × 42.91". Overall height: 39.37" to 42.91". Sadie™ Limited Three-Year Warranty.					
1	BSX-VST141	Black/Black	Black	49 lbs.	Each 422.00

## 1-Twenty-One High-Back Task Chair

Where quality meets value; a combination of comfort and affordability.

- Perfect task chair for your home office, but also feels right at home in any corporate office environment.
- Fabric upholstery with padded seat and back cushions.
- 360-degree swivel motion and durable casters allow you to move anywhere in your workspace.
- Sadie™ Limited Three-Year Warranty.
- Meets or Exceeds ISTA Standards.

ID No.	Seat/Back Color	Base Color	Shpg. Wt.	Unit	Price
<b>B HIGH-BACK TASK CHAIR</b>					
Supports up to 250 lbs. Seat: 20" × 18". Back: 17" × 24". Overall height: 44.48".					
2	BSX-VST121	Black/Black	Black	40 lbs.	Each 345.00

## 1-Oh-One & 1-Oh-Two Mid-Back Task Chair

Breathable mesh back and durable sandwich mesh on the seat.

- Pneumatic seat height adjustment and 360 degree swivel.
- Suitable for use in office or home.
- Sadie™ Limited Three-Year Warranty.
- Meets or Exceeds ISTA Standards.

ID No.	Seat/Back Color	Base Color	Shpg. Wt.	Unit	Price
<b>C MID-BACK ARMLESS TASK CHAIR</b>					
Supports up to 250 lbs. Seat: 18" × 18". Back: 15" × 18". Overall height: 38.27".					
3	BSX-VST101	Black/Black	Black	25 lbs.	Each 136.00
<b>D MID-BACK TASK CHAIR WITH ARMS</b>					
Supports up to 250 lbs. Seat: 18" × 18". Back: 15" × 18". Overall height: 38.27".					
4	BSX-VST102	Black/Black	Black	28 lbs.	Each 150.00

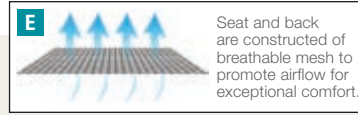
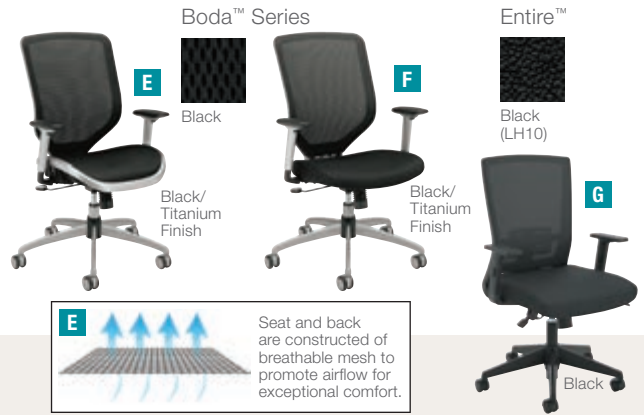

Seat and back are constructed of breathable mesh to promote airflow for exceptional comfort.

## HON Boda™ Series

Higher Quality Mesh at a Lower Price.

- Synchro-tilt and height-adjustable arms for a custom fit.
- Two styles—mesh back and seat or mesh back with mesh-covered cushioned seat.
- High-strength molded frame with titanium finish is engineered for years of reliable service.
- Five-star base with casters for easy mobility.
- Backed by the HON Full Lifetime Warranty.
- Meets or exceeds ANSI/BIFMA Standards.

ID No.	Seat/Back Color	Base Color	Shpg. Wt.	Unit	Price
<b>E MESH HIGH-BACK TASK CHAIR WITH MESH SEAT</b>					
Comfortable mesh seat for breathable support. Supports up to 250 lbs. Seat: 20" × 18¼". Back: 19¼" × 24¼". Overall height: 40" to 44¼".					
5	HON-MH02MST1C	Black/Black	Titanium	43 lbs.	Each 940.00
<b>F MESH HIGH-BACK TASK CHAIR</b>					
Black sandwich mesh fabric seat has two layers of padding for increased comfort. Supports up to 250 lbs. Seat: 20¾" × 17¾". Back: 19¾" × 24¼". Overall height: 39¾" to 44".					
6	HON-MH01MM10C	Black/Black	Titanium	43 lbs.	Each 815.00

## Entire™ Mesh High-Back Task Chair

Discover excellence without expense.

- Controls on this chair are easy to reach and simple to understand, featuring only one lever.
- Breathable mesh back conforms to the upper body for added comfort.
- Contemporary seat cushion features multi-density layered foam for comfort and support.
- Convenient center-tilt with upright lock allows the user to recline, and the tilt tension control adapts to people of differing weights.
- Lumbar adjustment adapts to support the lower back.
- Backed by the HON Limited Five-Year Warranty.

ID No.	Seat/Back Color	Base Color	Shpg. Wt.	Unit	Price
<b>G MESH HIGH-BACK TASK CHAIR</b>					
Supports up to 250 lbs. Seat: 19½" × 19¼". Back: 16¾" × 22¾". Overall height: 43½".					
7	BSX-VL541LH10	Black/Black	Black	33 lbs.	Each 403.00

For more information on additional chair features see page 80.



Prices subject to change without notice.  
Visit our website for the latest pricing and product information.



A

Black (SB11)

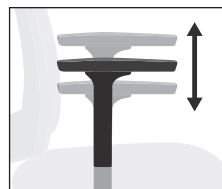

Height adjustable arms on all chairs.



A

Black (MM10)



B

Black (MM10)



Black SofThread™ Leather (SB11)



Black SofThread™ (MM10)



Black Mesh (MST3)



C

Black (MM10)



D

Black (MST3)

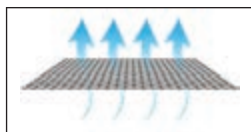

Benefit of Mesh  
The VL534 back and seat are constructed of breathable mesh to promote airflow for exceptional comfort.



## HON.

### Prominent™ Mesh Chairs

Breathable woven mesh back conforms to the upper body for added support.

- Contoured, breathable mesh seat cushion features two layers of padding for greater comfort.
- Frame and five-star base are molded from fiberglass-reinforced resin for increased durability.
- Adaptable design for professional, administrative and technology functions as well as meeting workspaces.
- Backed by the HON Limited Five-Year Warranty.

ID No.      Seat/Back Color      Base Color      Shpg. Wt.      Unit      Price

#### A MESH HIGH-BACK TASK CHAIR WITH ENHANCED CONTROLS

Asynchronous controls utilize multiple independent controls to provide the widest range of comfort options. Meets or Exceeds ISTA Performance Standards. Supports up to 250 lbs. Seat: 21" x 20". Back: 19" x 25". Overall height: 41" to 45".

##### SofThread™ Leather

1	BSX-VL532SB11	Black/Black	Black	50 lbs.	Each	442.00
---	---------------	-------------	-------	---------	------	--------

##### Fabric

2	BSX-VL532MM10	Black/Black	Black	72 lbs.	Each	463.00
---	---------------	-------------	-------	---------	------	--------

#### B HIGH-BACK TASK STOOL

Meets or Exceeds ANSI/BIFMA Standards and ISTA Performance Standards. Supports up to 250 lbs. Seat: 20.5" x 17.1". Back: 17.1" x 22.8". Overall height: 42.9" to 50".

3	HON-VL539MM10	Black/Black	Black	44 lbs.	Each	358.00
---	---------------	-------------	-------	---------	------	--------

#### C MESH HIGH-BACK TASK CHAIR WITH STANDARD CONTROLS

Height adjustable arms. Supports up to 250 lbs. Seat: 21½" x 18". Back: 18¼" x 23". Overall height: 38½" to 42½".

##### SofThread™ Leather

4	BSX-VL531SB11	Black/Black	Black	36 lbs.	Each	415.00
---	---------------	-------------	-------	---------	------	--------

##### Mesh

5	BSX-VL531MM10	Black/Black	Black	36 lbs.	Each	390.00
---	---------------	-------------	-------	---------	------	--------

#### D MESH HIGH-BACK TASK CHAIR WITH MESH SEAT

Supports up to 250 lbs. Seat: 20½" x 19½". Back: 19½" x 22½". Overall height: 41½".

6	BSX-VL534MST3	Black/Black	Black	42 lbs.	Each	478.00
---	---------------	-------------	-------	---------	------	--------



For more information on additional chair features see page 80.



## Interval Series

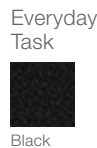
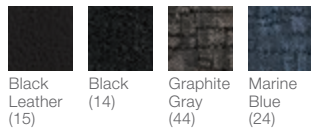

## Alera® Interval Series

Compact and comfortable—ideal for all-day seating in tight spaces.

- Molded plastic, impact-resistant shell.
- Waterfall seat edge helps relieve pressure points on the underside of legs.
- Back height adjustment for optimal lumbar support.
- Durable premium fabric upholstery designed to resist abrasions and fading.
- Optional Arms sold separately.
- Manufacturer's limited five-year warranty.
- Contains 5% post-consumer recycled content, 30% total recycled content.
- Meets or exceeds ANSI/BIFMA Standards.

ID No.	Seat/Back Color	Base Color	Shpg. Wt.	Unit	Price
--------	-----------------	------------	-----------	------	-------

### A SWIVEL/TILT MESH CHAIR

Supports up to 275 lbs. Seat: 19<sup>7</sup>/<sub>8</sub>" × 18<sup>1</sup>/<sub>4</sub>". Back: 16<sup>1</sup>/<sub>2</sub>" × 17<sup>3</sup>/<sub>8</sub>". Overall height: 34<sup>7</sup>/<sub>8</sub>" to 39<sup>1</sup>/<sub>2</sub>".

#### Leather

1	ALE-IN4815	Black/Black	Black	30 lbs.	Each	<del>265.00</del>
---	------------	-------------	-------	---------	------	-------------------

#### Fabric

2	ALE-IN4814	Black/Black	Black	30 lbs.	Each	255.00
3	ALE-IN4844	Graphite Gray/Black	Black	30 lbs.	Each	255.00
4	ALE-IN4824	Marine Blue/Black	Black	30 lbs.	Each	255.00

## Alera® Logan Series

Contoured cushions with mesh fabric upholstery provide plush comfort and all-day support.

- Closed loop arms with padded mesh fabric arm pads.
- Five-star base with hooded casters for easy mobility.
- Manufacturer's limited five-year warranty.
- Meets or exceeds ANSI/BIFMA Standards.

ID No.	Seat/Back Color	Base Color	Shpg. Wt.	Unit	Price
--------	-----------------	------------	-----------	------	-------

### B MESH HIGH-BACK SWIVEL/TILT CHAIR

Supports up to 275 lbs. Seat: 21<sup>1</sup>/<sub>2</sub>" × 21". Back: 21<sup>1</sup>/<sub>4</sub>" × 27<sup>3</sup>/<sub>4</sub>". Overall height: 41<sup>1</sup>/<sub>2</sub>" to 45<sup>1</sup>/<sub>8</sub>".

5	ALE-LG41ME10B	Black/Black	Black	43 lbs.	Each	385.00
---	---------------	-------------	-------	---------	------	--------

## Everyday Task Stool & Chair

The one stool suitable for all your everyday work tasks.

- Contoured padded seat and back provides superior comfort and ergonomics.
- Waterfall seat edge relieves pressure on the back of legs and knees.
- Adjustable height padded arms.
- Manufacturer's limited five-year warranty.
- Contains 5% post-consumer recycled content, 20% total recycled content.
- Meets or exceeds ANSI/BIFMA Standards.

ID No.	Seat/Back Color	Base Color	Shpg. Wt.	Unit	Price
--------	-----------------	------------	-----------	------	-------

### C STOOL

Adjustable foot rest for support and to keep feet from hanging. Supports up to 275 lbs. Seat: 19<sup>1</sup>/<sub>2</sub>" × 17<sup>3</sup>/<sub>8</sub>". Back: 18<sup>1</sup>/<sub>2</sub>" × 18<sup>1</sup>/<sub>2</sub>". Overall height: 39<sup>3</sup>/<sub>8</sub>" to 48".

#### Mesh

6	ALE-TE4617	Black/Black	Black	36 lbs.	Each	399.00
---	------------	-------------	-------	---------	------	--------

### D OFFICE CHAIR

Supports up to 275 lbs. Seat: 18<sup>1</sup>/<sub>2</sub>" × 17<sup>3</sup>/<sub>8</sub>". Back: 18" × 17<sup>1</sup>/<sub>2</sub>". Overall height: 35" to 38<sup>3</sup>/<sub>4</sub>".

#### Mesh

7	ALE-TE4817	Black/Black	Black	31 lbs.	Each	399.00
---	------------	-------------	-------	---------	------	--------

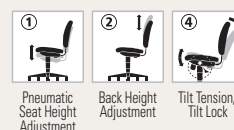

For more information on additional chair features see page 80.

Prices subject to change without notice. Visit our website for the latest pricing and product information.

# Seating Mesh



Macklin Series

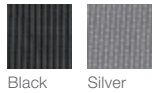

MB Series

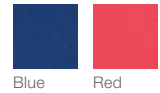

## Macklin Series

High fashion at a great value.

- Sleek styling.
- Comfortable design.
- Quick-to-assemble.
- Manufacturer's limited five-year warranty.
- Meets or exceeds ANSI/BIFMA Standards.



ID No.	Seat/Back Color	Base Color	Shpg. Wt.	Unit	Price
--------	-----------------	------------	-----------	------	-------

### A MID-BACK ALL-MESH OFFICE CHAIR

A modern office chair with breathable mesh seat and back. Keeps you cool where you need it most. Smart and stylish design for a sleek look in your office. Waterfall seat edge reduces pressure points at the back of the knee. Durable mesh upholstery for longevity. Contoured arms provide support while allowing chair to easily fit under your desk. Supports up to 275 lbs. Seat: 19" x 27". Back: 17.75" x 20.88". Overall height: 35.88" to 39".

1	ALE-KA14218	Black	Black	26 lbs.	Each	345.00
2	ALE-KA14248	Silver	Pewter	26 lbs.	Each	345.00

## Alera® MB Series

A modern mesh office chair designed for style and comfort.

- Breathable mesh back for all-day cool comfort.
- Long-lasting mesh and fabric upholstery withstands constant use.
- Individually wrapped coil-springs inside a generously cushioned seat provides exceptional mattress-like comfort all-day long.
- Subtly arched loop arms provide support while allowing chair to easily fit under your desk.
- Domed five-star base with casters for easy mobility.
- Manufacturer's limited five-year warranty.
- Contains 17% post-consumer recycled content.
- Meets or exceeds ANSI/BIFMA Standards.

ID No.	Seat/Back Color	Base Color	Shpg. Wt.	Unit	Price
--------	-----------------	------------	-----------	------	-------

### B MID-BACK OFFICE CHAIR

Supports up to 275 lbs. Seat: 21¼" x 20½". Back: 18½" x 22". Overall height: 39¾" to 43¾".

3	ALE-MB4718	Black	Black	31 lbs.	Each	289.00
4	ALE-MB4728	Blue/Black	Black	31 lbs.	Each	289.00
5	ALE-MB4748	Gray/Black	Black	31 lbs.	Each	289.00
6	ALE-MB4738	Red/Black	Black	31 lbs.	Each	289.00

EY Series



Black Mesh



## Alera® EY Series

Slim profile chair with a generously proportioned seat and mesh back.

- Pneumatic height adjustment.
- Adjustable lumbar support.
- Height-adjustable padded T-bar arms.
- Durable five-star arched nylon base with easy-rolling casters.
- Manufacturer's limited five-year warranty.
- Meets or exceeds ANSI/BIFMA Standards.

ID No.	Seat/Back Color	Base Color	Shpg. Wt.	Unit	Price
--------	-----------------	------------	-----------	------	-------

### C MULTIFUNCTION CHAIR

Supports up to 275 lbs. Seat: 21¼" x 20½". Back: 19" x 23". Overall height: 40" to 44". Manufacturer's limited five year warranty.

7	ALE-EY4214S	Black	Black	39 lbs.	Each	375.00
---	-------------	-------	-------	---------	------	--------

### D SWIVEL TILT CHAIR

Supports up to 275 lbs. Seat: 21¼" x 20½". Back: 19" x 23". Overall height: 40" to 44". Manufacturer's limited five year warranty.

8	ALE-EY4214B	Black	Black	35 lbs.	Each	345.00
---	-------------	-------	-------	---------	------	--------

For more information on additional chair features see page 80.







**HON.**

## ValuTask® Series Task Chairs

**Breathable mesh back conforms to the upper body for added comfort.**

- Upholstered seat features detailed stitching for an upscale look.
- Waterfall seat edge promotes better leg circulation.
- Center-tilt mechanism rotates the seat from a point at the center to comfortably recline.
- Tilt tension controls the rate and ease of recline.
- Upright tilt lock secures the chair in the full upright position.
- Pneumatic seat height adjustment moves the seat up and down to adapt to various body heights.
- 360-degree swivel provides freedom of movement in any direction.
- Warranted for users up to 250 lbs.
- Backed by the HON Limited Five-Year Warranty.
- Meets or exceeds ISTA Performance Standards.

ID No.	Seat/Back Color	Base Color	Shpg. Wt.	Unit	Price
--------	-----------------	------------	-----------	------	-------

**A MESH MID-BACK ARMLESS TASK CHAIR**

Supports up to 250 lbs. Seat: 19" x 18". Back: 18" x 18". Overall height: 36" to 40".

1	BSX-VL205MM10T	Black	Black	29 lbs.	Each	237-00
---	----------------	-------	-------	---------	------	--------

**B HEIGHT ADJUSTABLE ARM KIT**

Includes two black arms that can be easily added to the HVL205, HVL210 and HVL215 chairs. Easy to install.

2	BSX-VL995	Black			Each	237-00
---	-----------	-------	--	--	------	--------

## HVL521 Mesh Chair

**Comfort, style and value that work as hard as you do.**

- Comfortable and breathable mesh back for all-day comfort and support.
- Fabric upholstered seat.
- Five-star base with casters for easy mobility.
- Padded armrests offer comfort and support.
- Fixed polyurethane arms.
- Backed by the HON Limited Five-Year Warranty.

ID No.	Seat/Back Color	Base Color	Shpg. Wt.	Unit	Price
--------	-----------------	------------	-----------	------	-------

**C HVL521 MESH MID-BACK TASK CHAIR WITH FIXED ARMS**

Breathable mesh back and fabric-upholstered seat. Padded armrests offer comfort and support. Supports up to 250 lbs. Seat: 19½" x 17¾". Back: 18¾" x 21½". Overall height: 41".

3	BSX-VL521VA10	Black	Black	30 lbs.	Each	323-00
---	---------------	-------	-------	---------	------	--------

## Torch™ Mesh Mid-Back Task Chair

**Surprising style and comfort at a highly affordable price.**

- Design combines slender profile, with full-scale comfort.
- Contoured seat cushions feature multiple layers of foam for added comfort and support.
- Comfort adjustments include center-tilt with tension and upright lock.
- Mid-back design is ideal for any management, professional or administrative application.
- Backed by the HON Limited Five-Year Warranty.

ID No.	Seat/Back Color	Base Color	Shpg. Wt.	Unit	Price
--------	-----------------	------------	-----------	------	-------

**D MESH MID-BACK TASK CHAIR**

Supports up to 250 lbs. Seat: 19½" x 18¼". Back: 17¾" x 21¾". Overall height: 40½".

4	BSX-VL511LH10	Black	Black	48 lbs.	Each	276-00
---	---------------	-------	-------	---------	------	--------

## HVL525 High-Back Mesh Chair

**Upscale feel at a compelling price.**

- Open back design creates a contemporary aesthetic.
- The simple, understandable controls include seat height to fit your body, and center-tilt to provide comfort.
- High back frame with support bar delivers substantial, long-lasting support.
- Contoured mesh back is ergonomically sculpted to increase lower back support.
- Breathable mesh back conforms to the upper body for added comfort.
- Fixed loop arms provide added comfort.
- Warranted for users up to 250 lbs.
- Backed by the HON Limited Five-Year Warranty.

ID No.	Seat/Back Color	Base Color	Shpg. Wt.	Unit	Price
--------	-----------------	------------	-----------	------	-------

**E MESH MID-BACK TASK CHAIR**

Supports up to 250 lbs. Seat: 19¾" x 19". Back: 19¾" x 23". Overall height: 42¾".

5	BSX-VL525ES10	Black	Black	30 lbs.	Each	329-00
---	---------------	-------	-------	---------	------	--------



For more information on additional chair features see page 80.



**SAFCO**

## Gist™ Series Chair

Black mesh woven with curved silver strands that reflect light.

- Soft, pressure fit back support with vertical adjustment.
- Minimal four step assembly.
- 300 lb. maximum weight rated.
- Manufacturer's limited lifetime warranty.
- Meets or exceeds ANSI/BIFMA Standards.

ID No.	Seat/Back Color	Base Color	Shpg. Wt.	Unit	Price
--------	-----------------	------------	-----------	------	-------

### A MULTI-PURPOSE CHAIR

Standard with height adjustment, swivel tilt mechanism, tilt tension and tilt lock. Fixed arms and black base. Supports up to 300 lbs. Seat: 18" × 17½". Back: 18" × 20¾". Overall height: 37¾" to 41¾".

1	MLN-GS11SVRBLK	Silver/Black	Black	49 lbs.	Each	<del>550.00</del>
---	----------------	--------------	-------	---------	------	-------------------

### B TASK CHAIR

Height-adjustable T-arms and black base make this chair suitable for any office environment. Standard with synchro-tilt mechanism, height adjustment and seat slider. Tilt tension and lock standard. Supports up to 300 lbs. Seat: 18" × 19½". Back: 18" × 22¾". Overall height: 37¾" to 41¾".

2	MLN-GS22SVRBLK	Silver/Black	Black	54 lbs.	Each	<del>650.00</del>
---	----------------	--------------	-------	---------	------	-------------------

## Mercado™ Chair

Stylish combination of fabric and mesh for total comfort.

- Lumbar support helps reduce back pain.
- Arms adjust to accommodate each user's needs.
- Manufacturer's limited lifetime warranty.

ID No.	Seat/Back Color	Base Color	Shpg. Wt.	Unit	Price
--------	-----------------	------------	-----------	------	-------

### C MID-BACK FABRIC/MESH CHAIR

Supports up to 250 lbs. Seat: 18" × 18". Back: 18" × 20½". Overall height: 38" to 41".

3	MLN-3200	Black/Black	Black	55 lbs.	Each	<del>450.00</del>
---	----------	-------------	-------	---------	------	-------------------

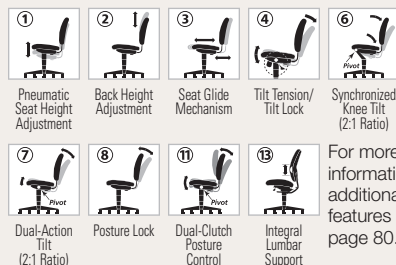

For more information on additional chair features see page 80.



## Vue™ Intensive-Use Mesh Task Chair

Rated for 24/7 use.

- Back provides ample support and ergonomic shaping to provide all-day comfort and may help prevent fatigue.
- Breathable nylon mesh keeps users cool and comfortable throughout every workday.
- Solid construction supports up to 500 lbs.
- Reinforced mechanism with back tilt that may help support a reclined position to allow a beneficial rocking motion throughout the day.
- Back height adjustment that may help support correct posture.
- Manufacturer's limited lifetime warranty.
- Meets or exceeds ANSI/BIFMA Standards.

ID No.	Color	Shpg. Wt.	Unit	Price
--------	-------	-----------	------	-------

### D INTENSIVE USE MESH TASK CHAIR

Supports up to 500 lbs. Seat: 20½" × 20". Back: 18¾" × 18". Overall height: 31" to 37".

4	SAF-3397BV	Black	49 lbs.	Each	<del>520.00</del>
5	SAF-3397BL	Black	49 lbs.	Each	<del>520.00</del>

## Alday™ Intensive-Use Chair

Designed as an extensive-use, 24/7 task chair.

- Ample supportive cushioning in the seat and back deliver ergonomic shaping to fit a variety of body types.
- Durable plastic ergo core back and reinforced mechanism adds more comfort and overall strength.
- Wide five-star base with casters provide extreme stability.
- Rated up to 500 lbs.
- Back tilt helps to support a reclined posture and may allow a beneficial rocking motion that may help increase movement throughout the day.
- Manufacturer's limited lifetime warranty.

ID No.	Color	Shpg. Wt.	Unit	Price
--------	-------	-----------	------	-------

### E INTENSIVE USE CHAIR

Supports up to 500 lbs. Seat: 20½" × 20". Back: 18¾" × 18". Overall height: 35½" to 38".

6	SAF-3391BV	Black	52½ lbs.	Each	<del>554.00</del>
7	SAF-3391BL	Black	52½ lbs.	Each	<del>554.00</del>
8	SAF-3399BL	Black		Pair	<del>96.00</del>

### OPTIONAL T-PAD ADJUSTABLE ARMS

Offer a relaxing work environment by adding support to your Vue™ task chairs. Multiple height and width adjustments provide extreme comfort levels to each user. Manufacturer's limited lifetime warranty.



## 600 Multifunction Chair

Made with authentic TEMPUR® material—the same material found in Tempur-Pedic® mattresses.

- Conforms to your body's unique shape to provide comfort and support day after day.
- It's a chair that works with you, instead of against you.
- "Infinite" synchro mechanism with tilt lock feature.
- One-touch pneumatic height adjustment.
- Manufacturer's limited ten-year warranty.
- Greenguard Certified; Meets or Exceeds ANSI/BIFMA Standards.

ID No.	Seat/Back Color	Base Color	Shpg. Wt.	Unit	Price
--------	-----------------	------------	-----------	------	-------

### A MESH-BACK MULTIFUNCTION CHAIR

Supports up to 250 lbs.

Seat: 20.9" × 20.1". Back: 20.1" × 20.1". Overall height: 39.8" to 40.2".

1	EUT-TP600BK	Black Fabric/ Black Mesh	Black	66 lbs.	Each	<del>875.00</del>
2	EUT-TP600GY	Black Fabric/ Slate Mesh	Black	66 lbs.	Each	<del>875.00</del>

## 300 Leather Chair

The TEMPUR® material contours to the unique shape of your body, ensuring your comfort and support throughout the day.

- It's a chair that works with you, instead of against you.
- A luxurious leather finish creates a contemporary, sleek look that dresses up any office or conference room.
- Knee-tilt mechanism.
- Waterfall seat.
- Greenguard Certified; Meets or Exceeds ANSI/BIFMA Standards.

ID No.	Seat/Back Color	Base Color	Shpg. Wt.	Unit	Price
--------	-----------------	------------	-----------	------	-------

### B LEATHER HIGH-BACK CHAIR

Supports up to 250 lbs.

Seat: 20.5" × 18.5". Back: 20" × 28.39". Overall height: 43.25" to 46.25".

3	EUT-TP300	Black Leather	Black	67 lbs.	Each	<del>999.99</del>
---	-----------	---------------	-------	---------	------	-------------------

## 200 Multifunction Chair

Not only are you in control, but in style, too.

- TEMPUR® material works in complement with Raynor's innovative spring technology to give you a chair that responds to your body's every move.
- Also equipped with Outlast® cooling technology to regulate your skin temperature and reduce uncomfortable perspiration.
- Weight activated mechanism.
- One-touch pneumatic seat height adjustment.
- Manufacturer's limited ten-year warranty.
- Greenguard Certified; Meets or Exceeds ANSI/BIFMA Standards.

ID No.	Seat/Back Color	Base Color	Shpg. Wt.	Unit	Price
--------	-----------------	------------	-----------	------	-------

### C MESH-BACK MULTIFUNCTION CHAIR

Supports up to 250 lbs.

Seat: 20.39" × 18.5". Back: 19.75" × 22.5". Overall height: 39.69" to 45".

4	EUT-TP200BLKM	Black Fabric/ Black Mesh	Black	53 lbs.	Each	<del>999.99</del>
5	EUT-TP200NVY	Navy Fabric/ Black Mesh	Black	53 lbs.	Each	<del>999.99</del>

For more information on additional chair features see page 80.



1  
Pneumatic  
Seat Height  
Adjustment

2  
Back Height  
Adjustment

3  
Seat Glide  
Mechanism

4  
Tilt Tension/  
Tilt Lock

5  
Knee Tilt

13  
Integral  
Lumbar  
Support



Black Fabric/  
Slate Mesh

600 Multifunction Chair



Black  
Fabric

Black  
Mesh

Slate  
Mesh



Black Leather

300  
Leather  
Chair



Black  
Leather



Black Fabric/  
Black Mesh

200 Multifunction Chair



Black  
Fabric

Navy  
Fabric

Black  
Mesh

Prices subject to change without notice.  
Visit our website for the latest pricing and product information.



**A**

Black (CF10)

Gateway™ Series



Black (CF10)



**B**

Black (CF10)



**C**

Black (CU10)

Endorse® Collection



Black (CU10)



**D**

Black (CU10)

For more information on additional chair features see page 80.

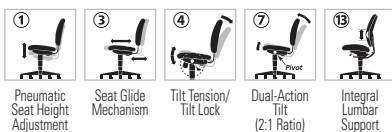

## HON Gateway™ Series

Tailor your lower back support with the built-in-lumbar adjustment.

- Breathable mesh back comfortably cradles your spine.
- Recline naturally with the center-tilt control.
- Sit and rotate with the 360-degree swivel base.
- HON limited five-year warranty. ✕

ID No.	Seat/Back Color	Base Color	Shpg. Wt.	Unit	Price
--------	-----------------	------------	-----------	------	-------

### A MID-BACK TASK CHAIR

Supports up to 250 lbs. Seat: 18.5" × 19". Back: 18" × 18.5". Overall height: 33.75" to 38.25". ① ④ ⑬

1	HON-GVHMZ1ACCF10	Black/Black	Black	40 lbs.	Each	<del>255.00</del>
---	------------------	-------------	-------	---------	------	-------------------

### B ARMLESS MID-BACK TASK CHAIR

Supports up to 250 lbs. Seat: 18.5" × 19". Back: 18" × 18.5". Overall height: 33.75" to 38.25". ① ④ ⑬

2	HON-GVNMZ1ACCF10	Black/Black	Black	40 lbs.	Each	<del>210.00</del>
---	------------------	-------------	-------	---------	------	-------------------



## Endorse® Collection

The geometry of comfort. The science of support.

- Sculpted organic form is a reflection of the advanced ergonomic function.
- To fit your body, this chair offers adjustable seat height/depth, lumbar height, and arm height/width.
- Synchro-tilt mechanism promotes circulation and proper back alignment.
- Multi-position tilt lock secures the chair at one of several preset reclining angles.
- Seat glide adjustment moves the seat cushion forward or back to adapt to upper leg length.
- Popular mid-back design is excellent in professional, management, technology and administrative settings.
- Backed by the HON Full Lifetime Warranty.
- Level 2 Certified; Meets or Exceeds ANSI/BIFMA Standards and ISTA Performance Standards; SCS Indoor Advantage Gold Certified. ✕

ID No.	Seat/Back Color	Base Color	Shpg. Wt.	Unit	Price
--------	-----------------	------------	-----------	------	-------

### C UPHOLSTERED MID-BACK TASK CHAIR

Back features fabric outer shell for a more formal appearance. Supports up to 300 lbs. Seat: 19.5" × 18.38". Back: 20.75" × 25.25". Overall height: to 46". ① ③ ④ ⑦ ⑬

3	HON-LWU2ACU10	Black/Black	Black	62 lbs.	Each	<del>660.00</del>
---	---------------	-------------	-------	---------	------	-------------------

### D MESH MID-BACK TASK CHAIR

Back is formed from 4-way stretch mesh for added comfort and ventilation. Supports up to 300 lbs. Seat: 19.5" × 17.75". Back: 19.25" × 25". Overall height: to 46". ① ③ ④ ⑦ ⑬

4	HON-LWIM2ACU10	Black/Black	Black	52 lbs.	Each	<del>660.00</del>
---	----------------	-------------	-------	---------	------	-------------------



## The Ergonomic Anatomy of Endorse



HON

# Ignition® Seating

Ignition addresses the needs of the total office with executive, work, task and guest seating solutions.

- Contoured seat and back reduce pressure points.
- Height- and width-adjustable arms provide a custom fit.
- Backed by the HON Full Lifetime Warranty.
- Contains 42% post-consumer recycled content, 45% total recycled content.
- Level 2 Certified; Meets or Exceeds ANSI/BIFMA Standards and ISTA Performance Standards; SCS Indoor Advantage Gold Certified.



ID No.      Seat/Back Color      Base Color      Shpg. Wt.      Unit      Price

### A EXECUTIVE HIGH-BACK CHAIR

Comfortable behind the desk or around the conference table. Five-star base with casters for easy mobility. Quick-adjust back height for easy lumbar positioning. Supports up to 300 lbs. Seat: 20" x 18". Back: 20" x 28". Overall height: 42" to 48". ① ② ④

#### Fabric

1	HON-IE102CU10	Black/Black	Black	59 lbs.	Each	727.00
2	HON-IE102SS11	Black/Black	Black	57 lbs.	Each	4027.00

#### Leather

2	HON-IE102SS11	Black/Black	Black	57 lbs.	Each	4027.00
---	---------------	-------------	-------	---------	------	---------

### B MESH MID-BACK TASK CHAIR

Breathable mesh back provides added support for all-day seating comfort. Synchro-tilt and adjustable T-arms for a custom fit. Easy mobility on a five-star base with casters. Quick-adjust back height for easy lumbar positioning. Supports up to 300 lbs. Seat: 20" x 18.25". Back: 19" x 24". Overall height: to 46.5". ① ② ③ ④ ⑦

#### Fabric

3	HON-IW103CU10	Black/Black	Black	53 lbs.	Each	704.00
4	HON-IW103CU19	Iron Ore/Black	Black	53 lbs.	Each	704.00
5	HON-IW103CU98	Navy/Black	Black	56 lbs.	Each	704.00

#### Vinyl

6	HON-IW103UR10	Black/Black	Black	56 lbs.	Each	745.00
---	---------------	-------------	-------	---------	------	--------

### C FABRIC MID-BACK TASK CHAIR

Synchro-tilt with variable locking positions and independent back angle adjustment. Adjustable T-arms offer custom comfort. Five-star base with casters for easy mobility. Quick-adjust back height for easy lumbar positioning. Supports up to 300 lbs. Seat: 20" x 17.25". Back: 18.5" x 24". Overall height: to 44". ① ② ③ ④ ⑦

#### Fabric

7	HON-IW104CU10	Black/Black	Black	63 lbs.	Each	690.00
8	HON-IW104CU19	Iron Ore/Iron Ore	Black	63 lbs.	Each	690.00
9	HON-IW104CU98	Navy/Navy	Black	59 lbs.	Each	690.00

#### Vinyl

10	HON-IW104UR10	Black/Black	Black	59 lbs.	Each	709.00
----	---------------	-------------	-------	---------	------	--------

### D FABRIC LOW-BACK TASK CHAIR

Offers comfortable support for the active worker. Height- and width-adjustable arms for custom comfort. Five-star base with casters for easy mobility. Quick-adjust back height for easy lumbar positioning. Supports up to 300 lbs. Back: 17.5" x 21.75". Overall height: to 41". ① ② ④

#### Fabric

11	HON-IT105CU10	Black/Black	Black	51 lbs.	Each	650.00
12	HON-IT105CU19	Iron Ore/Iron Ore	Black	51 lbs.	Each	650.00
13	HON-IT105CU98	Navy/Navy	Black	51 lbs.	Each	650.00

#### Vinyl

14	HON-IT105UR10	Black/Black	Black	51 lbs.	Each	626.00
----	---------------	-------------	-------	---------	------	--------

### E 4-WAY STRETCH MESH BACK CAFE HEIGHT STOOL

Breathable mesh back increases airflow and enhances support. Seating platform supports widely diverse body types and job functions. Wall-saver leg design prevents damage to nearby walls and furniture. Nylon glides provide stability and move effortlessly on all surfaces. Fixed arms provide upper body support. Supports up to 300 lbs. Seat: 19" x 17". Back: 18" x 18". Overall height: to 47".

15	HON-IC108IMCU10	Black/Black	Black	37 lbs.	Each	576.00
16	HON-IC108IMCU98	Navy/Black	Black	37 lbs.	Each	556.00
17	HON-IC108IMCU67	Ruby/Black	Black	37 lbs.	Each	556.00



Black Leather (SS11)



Black (CU10)



Iron Ore (19)



Navy (98)



Black (CU10)

For more information on additional chair features see page 80.



① Pneumatic Seat Height Adjustment      ② Back Height Adjustment      ③ SSeat Guide Mechanism



④ Tilt Tension/Tilt Lock      ⑦ Dual-Action Tilt (2:1 Ratio)

#### In Stock Upholstery



Black Leather (SS11)      Black (CU10)



Ruby (CU67)      Black Vinyl (UR10)

#### Special Order Upholstery



Iron Ore (19)      Navy (98)

**NO RETURN** Requires additional lead time and cannot be returned.



**A**

Frost (C22)



**B**

Black Vinyl (U10)



**C**

Pear (C84)/  
Black/Black



**D**

Iron Ore (C19)/  
Black/Black



**E**

Frost (C22)/  
Black/Black

VISIT US ONLINE FOR OUR FULL ASSORTMENT OF

Colors & Options

For more information on additional chair features see page 80.



### In Stock Upholstery



Black Vinyl (U10)  
Black (C10)

### In Stock Mesh



Black Mesh

### Special Order Upholstery



Apricot (C47)  
Espresso (C49)  
Frost (C22)  
Iron Ore (C19)  
Navy (C98)  
Pear (C84)



Requires additional lead time and cannot be returned.

# HON.



## Ignition® 2.0 Seating

Ignition fits anyone, any task, any space.

- Adjustable lumbar support.
- 4-way stretch mesh enhanced mesh provides optimal comfort.
- Height- and width-adjustable arms provide a custom fit.
- Limited synchro-tilt with tension and lock puts you in control of your posture and comfort.
- Backed by the HON Full Lifetime Warranty.
- Contains 11% post-consumer recycled content, 14% total recycled content.
- Level 2 Certified; Meets or Exceeds ANSI/BIFMA Standards and ISTA Performance Standards; SCS Indoor Advantage Gold Certified.

ID No. \_\_\_\_\_ Seat/Back Color \_\_\_\_\_ Base Color \_\_\_\_\_ Shpg. Wt. Unit Price

### A UPHOLSTERED MID-BACK TASK CHAIR WITH LUMBAR

Supports up to 300 lbs.

Seat: 20" x 19". Back: 19" x 29". Overall height: to 45". ① ③ ④

#### Fabric with Adjustable Arms

1	HON-I2UL2AC10TK	Black/Black	Black	49 lbs.	Each	<del>661.00</del>
2	HON-I2UL2A__TK*	(Special Order)/ (Special Order)	Black	46 lbs.	Each	<del>661.00</del>

#### Vinyl with Adjustable Arms

3	HON-I2UL2AU10TK	Black/Black	Black	46 lbs.	Each	<del>661.00</del>
---	-----------------	-------------	-------	---------	------	-------------------

### B UPHOLSTERED MID-BACK TASK CHAIR

Supports up to 300 lbs. Seat: 20" x 19". Back: 19" x 29". Overall height: to 45". ① ④

#### Vinyl with Fixed Arms

4	HON-I2UL2FU10TK	Black/Black	Black	53 lbs.	Each	<del>661.00</del>
5	HON-I2UL2F__TK*	(Special Order)/ (Special Order)	Black	53 lbs.	Each	<del>661.00</del>

### C MID-BACK MESH TASK CHAIR

Advanced synchro-tilt control mechanism is the best HON has to offer, and reclines just the way you like it. Adjustable lumbar support. Easy assembly. Supports up to 300 lbs. Seat: 20" x 19". Back: 19" x 29". Overall height: 44" to 45". ① ③ ④

#### Fabric

6	HON-I2M2AMLC10TK	Black/Black	Black	54 lbs.	Each	<del>670.00</del>
7	HON-I2M2AML__TK*	(Special Order)/Black	Black	54 lbs.	Each	<del>670.00</del>

#### Vinyl

8	HON-I2M2AMLU10TK	Black/Black	Black	44 lbs.	Each	<del>661.00</del>
---	------------------	-------------	-------	---------	------	-------------------

### D REACTIV MID-BACK TASK CHAIR

Supports up to 300 lbs.

Seat: 20" x 19". Back: 19" x 29". Overall height: 40" to 45". ③

#### Fabric

9	HON-I2MRL2A__TK*	(Special Order)/Black	Black	46 lbs.	Each	<del>660.00</del>
---	------------------	-----------------------	-------	---------	------	-------------------

### E LOW-BACK MESH TASK CHAIR

Breathable mesh back cradles your spine with natural lumbar support and increases airflow. The synchro-tilt control mechanism with seat slider reclines the back and seat in the perfect ratio to give you a natural posture, whether sitting upright or leaning back. Height- and width-adjustable arms and an adjustable lumbar support provide a custom fit. Very easy assembly. Supports up to 300 lbs. Seat: 19" x 18". Back: 18" x 26". Overall height: 41" to 42". ① ③ ④

#### Fabric

10	HON-I2L1AMLC10TK	Black/Black	Black	54 lbs.	Each	<del>579.00</del>
11	HON-I2L1AML__TK*	(Special Order)/Black	Black	54 lbs.	Each	<del>579.00</del>

#### Vinyl

12	HON-I2L1AMLU10TK	Black/Black	Black	54 lbs.	Each	<del>550.00</del>
----	------------------	-------------	-------	---------	------	-------------------



A

Black  
(CU10)



A

Ruby  
(CU67)



A

Black/  
Platinum  
(CU10P)

## HON

### Ignition® Seating



ID No. \_\_\_\_\_ Seat/Back Color \_\_\_\_\_ Base Color \_\_\_\_\_ Shpg. Wt. \_\_\_\_\_ Unit \_\_\_\_\_ Price \_\_\_\_\_

#### A MESH BACK GUEST CHAIR WITH SLED BASE

Versatile enough for the private office or the lobby. Breathable mesh back offers comfort and support. Sturdy sled base. Supports up to 300 lbs.  
Seat: 19" x 17". Back: 18" x 18". Overall height: 34".

##### Sled Base Fabric

1	HON-IB108IMCU10	Black/Black	Black	31 lbs.	Each	462.00
2	HON-IB108IMCU67	Ruby/Black	Black	31 lbs.	Each	462.00
3	HON-IB108IMCU22	Frost/Black	Black	31 lbs.	Each	459.00
4	HON-IB108IMCU10P	Black/Black	Platinum	31 lbs.	Each	459.00

##### Sled Base Vinyl

5	HON-IB108IMUR10	Black/Black	Black	31 lbs.	Each	446.00
6	HON-IB108IMUR10P	Black/Black	Platinum	31 lbs.	Each	459.00

#### B MESH BACK MOBILE STACKING CHAIR

Multipurpose chair stacks up to four high for space-efficient storage. Breathable mesh back offers comfort and support. Easily mobile on four dual-wheel casters.  
Supports up to 300 lbs. Seat: 18" x 18". Back: 18" x 18". Overall height: 34".

##### Stacking 4-Leg Fabric

7	HON-IS107HIMCU10	Black/Black	Black	33 lbs.	Each	462.00
8	HON-IS107HIM_*	(Special Order)/ Black	Black	33 lbs.	Each	446.00
9	HON-IS107IMCU10P	Black/Black	Platinum	28 lbs.	Each	459.00

##### Stacking 4-Leg Vinyl

10	HON-IS107HIMUR10	Black/Black	Black	33 lbs.	Each	434.00
11	HON-IS107IMUR10P	Black/Black	Platinum	28 lbs.	Each	459.00

##### In Stock Upholstery



Black (CU10) Ruby (CU67) Black Vinyl (UR10)

##### Special Order Upholstery



Apricot (CU47) Espresso (CU49) Frost (CU22) Iron Ore (CU19) Navy (CU98) Pear (CU84)



Requires additional lead time and cannot be returned.

VISIT US ONLINE FOR OUR FULL ASSORTMENT OF Colors & Options



B

Black  
(CU10)



B

Frost  
(CU22)



B

Black Vinyl  
(UR10)

20-MF-L-FCL

**\*IMPORTANT:** When ordering special order items, add the finish code to the model number. Codes vary in length and placement. Example: ABC-12345AB



A

Bittersweet (46)/  
Fog



B

Sterling (19)/  
Charcoal



C

Meadow  
(82)



D

Midnight (90)/  
Charcoal



E

Putty  
(22)



F

Ink  
(10)

VISIT US ONLINE FOR OUR FULL ASSORTMENT OF

Colors & Options



Solve answers the need for a higher level of personalization with three back options.

**4-Way Stretch Mesh Back**  
A unique mesh material that moves in four directions to provide responsive, multidirectional support for your lumbar region. The soft nature of the 4-way mesh envelops you in hammock-like comfort, while providing the right level of support throughout the day.

**Charcoal ReActiv® Back**  
The distinctive ReActiv hexagonal design is molded from flexible Thermoplastic Elastomers and contains dozens of intersecting nodes which flex independently and move with your body, delivering continuous support while allowing air to flow for lasting comfort.

**Upholstered ReActiv® Back**  
Utilizing all the comfort and supportive benefits of the ReActiv back, the upholstered ReActiv Back features a fabric cover over the hexagonal back. This provides additional support along with a more conservative aesthetic and a variety of design options.

## HON. Solve® Series



The answer for comfort and versatility.

- The synchronized seat and back move in harmony with the user to provide continuous comfort.
- Seat glide adjustment moves the seat cushion forward or back to adapt to upper leg length.
- Waterfall seat edge promotes better leg circulation. Height- and width-adjustable arms for upper body support.
- Backed by the HON Full Lifetime Warranty.
- Meets or Exceeds ANSI/BIFMA Standards and ISTA Performance Standards.

ID No.	Seat/Back Color	Base Color	Shpg. Wt.	Unit	Price
<b>A 4-WAY STRETCH MESH-BACK TASK CHAIR</b>					
Supports up to 300 lbs. Seat: 19" x 18". Back: 19" x 22". Overall height: 37" to 42".					
1	HON-SVM1ALC10TK	Ink/Black	Black	49 lbs.	Each <del>557.00</del>
2	HON-SVM1ALC__TK*	(Special Order)/Black	Black	49 lbs.	Each <del>557.00</del>
3	HON-SVM1ALICC__T*	(Special Order)/Charcoal	Black	49 lbs.	Each <del>589.00</del>
4	HON-SVM1ALIFC__T*	(Special Order)/Fog	Black	49 lbs.	Each <del>589.00</del>
<b>B REACTIV BACK TASK CHAIR</b>					
Supports up to 300 lbs. Seat: 19" x 18". Back: 19" x 22". Overall height: 37" to 42".					
5	HON-SVR1ACL10TK	Ink/Charcoal	Black	47 lbs.	Each <del>589.00</del>
6	HON-SVR1ACL__TK*	(Special Order)/Charcoal	Black	47 lbs.	Each <del>589.00</del>
<b>C UPHOLSTERED REACTIV BACK TASK CHAIR</b>					
Upholstered front over charcoal ReActiv® back. Supports up to 300 lbs. Seat: 19" x 18". Back: 19" x 22". Overall height: 37" to 42".					
7	HON-SVU1ACL10TK	Ink/Ink	Black	47 lbs.	Each <del>604.00</del>
8	HON-SVU1ACL__TK*	(Special Order)/	Black	47 lbs.	Each <del>604.00</del>
<b>D 4-WAY STRETCH MESH-BACK TASK STOOL</b>					
Supports up to 300 lbs. Seat: 19" x 18". Back: 19" x 22". Overall height: 43" to 53".					
9	HON-SVSM1ALC10T	Ink/Ink	Black	49 lbs.	Each <del>653.00</del>
10	HON-SVSM1ALC__T*	(Special Order)/Black	Black	49 lbs.	Each <del>653.00</del>
11	HON-SVSM1AICC__T*	(Special Order)/Charcoal	Black	51 lbs.	Each <del>645.00</del>
12	HON-SVSM1AIFC__T*	(Special Order)/Fog	Black	51 lbs.	Each <del>645.00</del>
<b>E REACTIV® BACK TASK STOOL</b>					
Supports up to 300 lbs. Seat: 19" x 18". Back: 19" x 22". Overall height: 43" to 53".					
13	HON-SVSR1ACL10T	Ink/Charcoal	Black	50 lbs.	Each <del>685.00</del>
14	HON-SVSR1ACL__T*	(Special Order)/Charcoal	Black	50 lbs.	Each <del>685.00</del>
<b>F UPHOLSTERED REACTIV® BACK TASK STOOL</b>					
Upholstered front over charcoal ReActiv® back. Supports up to 300 lbs. Seat: 19" x 18". Back: 19" x 22". Overall height: 43" to 53".					
15	HON-SVSU1ACL10T	Ink/Ink	Black	50 lbs.	Each <del>702.00</del>
16	HON-SVSU1ACL__T*	(Special Order)/	Black	50 lbs.	Each <del>702.00</del>

In Stock Upholstery



Ink  
(10)

In Stock - Backs



Black  
Mesh



Charcoal  
ReActiv™

For more information on additional chair features see page 80.

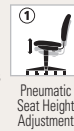

Pneumatic  
Seat Height  
Adjustment



Seat Glide  
Mechanism



Tilt Tension/  
Tilt Lock

Special Order Upholstery



Sterling  
(19)



Putty  
(22)



Meadow  
(82)



Bittersweet  
(46)



Midnight  
(90)



Dual-Action  
Tilt  
(2:1 Ratio)



Integral  
Lumbar  
Support

Special Order Mesh



Black  
Mesh



Charcoal  
Mesh



Fog  
Mesh



NO  
RETURN



Requires additional  
lead time and cannot  
be returned.

**\*IMPORTANT:** When ordering special order items, add the finish code to the model number. Codes vary in length and placement. Example: ABC-12345**AB**





A

Black Fabric (ST10)



B

Navy (CU98)



C

Black Leather (SR11)



D

Black/Mahogany (NSR11)



E

Black/Harvest (CSR11)



F

Black/Harvest (CSR11)

HON

## Pillow-Soft® Executive Seating

Superb comfort and attractive styling appropriate for executive, managerial and conference settings.

- Ergonomic support you need throughout the day, with the plush cushioning that makes sitting more comfortable than ever.
- Plush, tufted back cushion with recess at the base to cradle the lumbar region.
- Backed by the HON Full Lifetime Warranty.
- Level 2 Certified; Meets or Exceeds ANSI/BIFMA Standards; SCS Indoor Advantage Gold Certified.



### Pillow-Soft® 2090 Series

ID No.	Seat/Back Color	Base Color	Shpg. Wt.	Unit	Price
--------	-----------------	------------	-----------	------	-------

#### A EXECUTIVE HIGH-BACK CHAIR

Simple, understandable controls include seat height to fit your body, and center-tilt to provide comfort. Supports up to 250 lbs. Seat: 21" x 17.5". Back: 21" x 29.5". Overall height: 42.5" to 47.5". (1) (4)

**Fabric**—Padded-loop arms.

1	HON-2095HPWST10T	Black/Black	Black	57 lbs.	Each	<del>470.00</del>
---	------------------	-------------	-------	---------	------	-------------------

**Leather**—Padded-loop arms.

2	HON-2095HPWST11T	Black/Black	Black	57 lbs.	Each	<del>490.00</del>
---	------------------	-------------	-------	---------	------	-------------------

**Leather**—Standard-loop arms.

3	HON-2091SR69T	Burgundy/Burgundy	Black	57 lbs.	Each	<del>778.00</del>
---	---------------	-------------------	-------	---------	------	-------------------

**Fabric**—Features Nano-Tex® for superior stain resistance. Standard-loop arms.

4	HON-2091CU10T	Black/Black	Black	57 lbs.	Each	<del>620.00</del>
---	---------------	-------------	-------	---------	------	-------------------

5	HON-2091CU98T	Navy/Navy	Black	57 lbs.	Each	<del>620.00</del>
---	---------------	-----------	-------	---------	------	-------------------

**Leather**—Standard-loop arms.

6	HON-2091SR11T	Black/Black	Black	57 lbs.	Each	<del>778.00</del>
---	---------------	-------------	-------	---------	------	-------------------

#### B MANAGERIAL MID-BACK CHAIR

Simple, understandable controls include seat height to fit your body, and center-tilt to provide comfort. Supports up to 300 lbs. Seat: 22" x 21". Back: 22" x 19.63". Overall height: 37.25" to 41.75". (1) (4)

**Leather**

7	HON-2092SR11T	Black/Black	Black	54 lbs.	Each	<del>750.00</del>
---	---------------	-------------	-------	---------	------	-------------------

**Fabric**

8	HON-2092CU10T	Black/Black	Black	57 lbs.	Each	<del>600.00</del>
---	---------------	-------------	-------	---------	------	-------------------

9	HON-2092CU98T	Navy/Navy	Black	57 lbs.	Each	<del>600.00</del>
---	---------------	-----------	-------	---------	------	-------------------

#### C GUEST CHAIR

Supports up to 300 lbs. Seat: 21.5" x 20.75". Back: 21.5" x 19.25". Overall height: to 36".

**Leather**

10	HON-2093SR11T	Black/Black	Black	38 lbs.	Each	<del>621.00</del>
----	---------------	-------------	-------	---------	------	-------------------

**Fabric**

11	HON-2093CU10T	Black/Black	Black	38 lbs.	Each	<del>471.00</del>
----	---------------	-------------	-------	---------	------	-------------------

### Pillow-Soft® 2190 Series

ID No.	Color	Shpg. Wt.	Unit	Price
--------	-------	-----------	------	-------

#### D EXECUTIVE HIGH-BACK CHAIR WITH WOOD ACCENTS

Hardwood arms and base caps. Simple, understandable controls include seat height to fit your body, and center-tilt to provide comfort. Supports up to 300 lbs. Seat: 22" x 21". Back: 22" x 25". Overall height: 42" to 46.5". (1) (4)

**Leather**

12	HON-2191CSR11	Black/Harvest	60 lbs.	Each	<del>1,146.00</del>
----	---------------	---------------	---------	------	---------------------

13	HON-2191NSR11	Black/Mahogany	60 lbs.	Each	<del>1,146.00</del>
----	---------------	----------------	---------	------	---------------------

#### E MANAGERIAL MID-BACK CHAIR WITH WOOD ACCENTS

Hardwood arms and base caps. Simple, understandable controls include seat height to fit your body, and center-tilt to provide comfort. Supports up to 300 lbs. Seat: 22" x 21". Back: 22" x 19.63". Overall height: 37.25" to 41.75". (1) (4)

**Leather**

14	HON-2192CSR11	Black/Harvest	57 lbs.	Each	<del>1,116.00</del>
----	---------------	---------------	---------	------	---------------------

15	HON-2192NSR11	Black/Mahogany	57 lbs.	Each	<del>1,116.00</del>
----	---------------	----------------	---------	------	---------------------

#### F GUEST ARM CHAIR

Laminated hardwood frame for beauty and stability. Supports up to 300 lbs. Seat: 20.75" x 21.5". Back: 21.5" x 19.25". Overall height: to 35.5".

**Leather**

16	HON-2194CSR11	Black/Harvest	49 lbs.	Each	<del>887.00</del>
----	---------------	---------------	---------	------	-------------------

17	HON-2194NSR11	Black/Mahogany	49 lbs.	Each	<del>844.00</del>
----	---------------	----------------	---------	------	-------------------

#### Upholstery

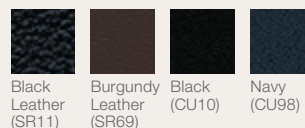

Black Leather (SR11) Burgundy Leather (SR69) Black (CU10) Navy (CU98)

#### Finishes

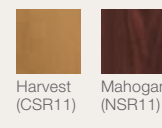

Harvest (CSR11) Mahogany (NSR11)



For more information on additional chair features see page 80.



Black



Black



Black



Black



## Alera® Kësson Series Office Chairs

So comfortable, you might forget you're at work!

- Molded foam in back and seat for resiliency and maximum comfort.
- Plushly padded arms for further support and comfort.
- Swivel/tilt mechanism for easy adjustments.
- Meets or Exceeds ANSI/BIFMA Standards.
- Manufacturer's limited five-year warranty.

ID No.	Seat/Back Color	Base Color	Shpg. Wt.	Unit	Price
<b>A PETITE OFFICE CHAIR</b>					
Designed and scaled with the petite user in mind. Supports up to 300 lbs. Seat: 20.07" × 19.68". Back: 19.88" × 23.22". Overall height: 35.43" to 38.97".					
1	ALE-KS4010	Black/Black	Black	45 lbs.	Each 399.00
<b>B MID-BACK OFFICE CHAIR</b>					
Designed for long-lasting, mattress-like comfort. Supports up to 300 lbs. Seat: 22.04" × 21.65". Back: 21.65" × 26.77". Overall height: 39.76" to 42.91".					
2	ALE-KS4210	Black/Black	Black	47 lbs.	Each 459.00
<b>C HIGH-BACK OFFICE CHAIR</b>					
Designed for long-lasting, mattress-like comfort. Supports up to 300 lbs. Seat: 22.44" × 23.22". Back: 22.04" × 30.31". Overall height: 43.30" to 47.24".					
3	ALE-KS4110	Black/Black	Black	52 lbs.	Each 479.00
<b>D BIG &amp; TALL OFFICE CHAIR</b>					
Supremely cushioned fabric chair provides maximum comfort and support for the big and tall user. Supports up to 450 lbs. Seat: 24.8" × 23.62". Back: 24.01" × 31.1". Overall height: 46.45" to 50.39".					
4	ALE-KS4510	Black/Black	Black	71 lbs.	Each 689.00



Pneumatic Seat Height Adjustment



Tilt/Tension/Tilt Lock

For more information on additional chair features see page 80.

**HON**

**Validate™ Series**

Seat and back cushions feature multi-density layered foam for comfort and support.

- Waterfall seat edge promotes better leg circulation.
- Fixed arms provide support when you need it.
- Backed by the HON Limited Five-Year Warranty.
- Meets or Exceeds ISTA Performance Standards.

ID No.	Seat/Back Color	Base Color	Shpg. Wt.	Unit	Price
--------	-----------------	------------	-----------	------	-------

**A HIGH-BACK EXECUTIVE CHAIR**

Discover excellence without expense. Chair features seat height and center-tilt controls as well as contemporary tapered loop arms and an integrated headrest. Supports up to 250 lbs. Seat: 19.75" x 18.25". Back: 20" x 26.5". Overall height: 42" to 47".

**SofThread™ Leather**

1	BSX-VL604SB11	Black/Black	Black	40 lbs.	Each	<del>272.00</del>
---	---------------	-------------	-------	---------	------	-------------------



Black Leather (SB11)

Validate™

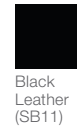

HVL601

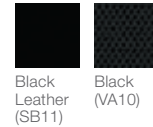

Black Leather (SB11)

Black (VA10)

**VL601 High-Back Executive Chairs**

Your office workhorse goes everywhere—from the conference room to the corner office.

- Adjustable seat height accommodates nearly any user.
- Easy-care leather helps maintain a neat appearance.
- Sturdy textured frame ensures strength and stability.
- Tailored stitching detail on the seat and back elevates the overall aesthetic.
- Backed by the HON Limited Five-Year Warranty.

ID No.	Seat/Back Color	Base Color	Shpg. Wt.	Unit	Price
--------	-----------------	------------	-----------	------	-------

**B EXECUTIVE HIGH-BACK LEATHER CHAIR**

Supports up to 250 lbs. Seat: 20.5" x 17". Back: 20.5" x 26.5". Overall height: 39.5" to 44".

**SofThread™ Leather**

2	BSX-VL601SB11	Black/Black	Black	38 lbs.	Each	<del>304.00</del>
---	---------------	-------------	-------	---------	------	-------------------

**C EXECUTIVE HIGH-BACK FABRIC CHAIR**

Supports up to 250 lbs. Seat: 20.5" x 17". Back: 20.5" x 26.5". Overall height: 39.5" to 44".

**Fabric**

3	BSX-VL601VA10	Black/Black	Black	38 lbs.	Each	<del>274.00</del>
---	---------------	-------------	-------	---------	------	-------------------



Black Leather (SB11)



Black (VA10)

**Crio™ Task Chair**

Breathable mesh back delivers cool comfort.

- Height- and width-adjustable arms customize your comfort.
- Adjustable lumbar support enhances lower back comfort.
- Simple, clean design gives any space a professional look.
- Reinforced five-star base offers incredible durability.
- Backed by the HON Limited Five-Year Warranty.
- Meets or Exceeds ANSI/BIFMA Standards and ISTA Performance Standards.



ID No.	Seat/Back Color	Base Color	Shpg. Wt.	Unit	Price
--------	-----------------	------------	-----------	------	-------

**D HIGH-BACK TASK CHAIR WITH STANDARD CONTROLS**

Supports up to 250 lbs. Seat: 20" x 20". Back: 19" x 26". Overall height: 39" to 43".

4	BSX-VL581ES10T	Black/Black	Black	38 lbs.	Each	<del>359.00</del>
---	----------------	-------------	-------	---------	------	-------------------

**E HIGH-BACK TASK CHAIR WITH ADVANCED CONTROLS**

Supports up to 250 lbs. Seat: 20" x 18". Back: 15" x 26". Overall height: 30" to 38.25".

5	BSX-VL582ES10T	Black/Black	Black	28 lbs.	Each	<del>434.00</del>
---	----------------	-------------	-------	---------	------	-------------------



Black (ES10)



Black (ES10)



For more information on additional chair features see page 80.

Prices subject to change without notice. Visit our website for the latest pricing and product information.

# Seating Office

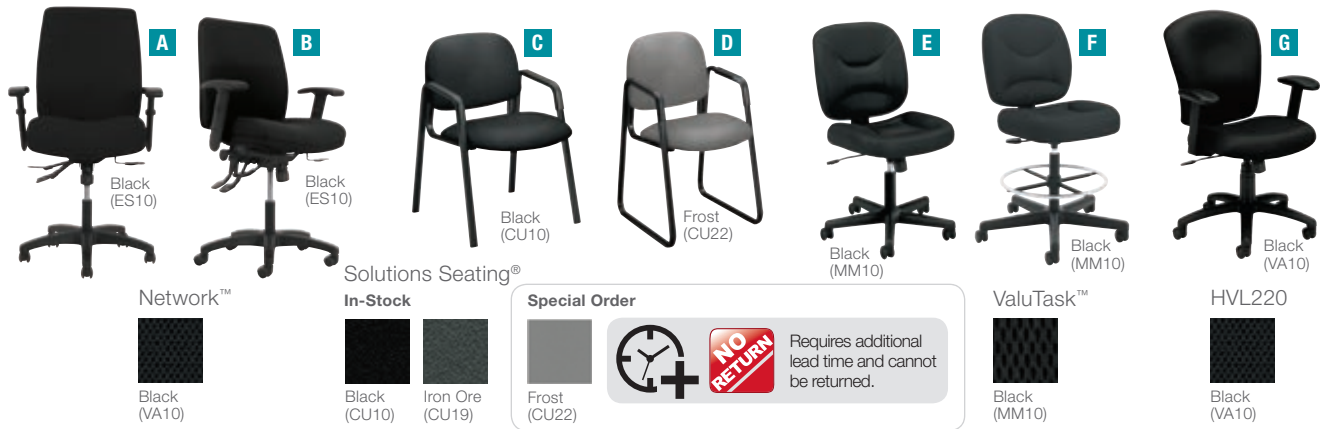

## HON.

### Network™ Series Task Chairs

Enjoy classic comfort in a modern chair design.

- Back moves up and down to create a perfect fit for a variety of users.
- Height- and width-adjustable arms provide a custom fit.
- Backed by the HON Limited Five-Year Warranty.
- Meets or Exceeds ANSI/BIFMA Standards and ISTA Performance Standards.

ID No.	Seat/Back Color	Base Color	Shpg. Wt.	Unit	Price
<b>A HIGH-BACK TASK CHAIR WITH ASYNCHRONOUS CONTROL</b>					
Asynchronous control mechanism with seat slider offers a full range of reclining positions. Supports up to 250 lbs. Seat: 19.7" x 18.4". Back: 20.1" x 24.63". Overall height: to 42".					
1	HON-VL283A2VA10T	Black/Black	Black	54 lbs.	Each <del>472.00</del>
<b>B MID-BACK TASK CHAIR</b>					
Supports up to 250 lbs. Seat: 19.8" x 18.4". Back: 19.3" x 21.7". Overall height: to 31.5".					
2	HON-VL282Z1VA10T	Black/Black	Black	36 lbs.	Each <del>335.00</del>
<b>With Asynchronous Control</b>					
3	HON-VL282A2VA10T	Black/Black	Black	47 lbs.	Each <del>390.00</del>

### Solutions Seating® 4000 Series

The answer for managerial, conference and reception seating.

- Cushion design supports lumbar and helps reduce fatigue.
- Stain-resistant protection on upholstery helps maintain a clean appearance.
- Durable, strong frame ensures long-term stability.
- The simplified set of elements enables quick and easy reconfiguration and customization, allowing you to adjust and adapt as needs change.
- Backed by the HON Full Lifetime Warranty.
- Contains 26% post-consumer recycled content, 30% total recycled content.
- Level 2 Certified; Meets or Exceeds ANSI/BIFMA Standards and ISTA Performance Standards; SCS Indoor Advantage Gold Certified

ID No.	Seat/Back Color	Base Color	Shpg. Wt.	Unit	Price
<b>C GUEST CHAIR</b>					
Supports up to 250 lbs. Seat: 20" x 18". Back: 21" x 15". Overall height: to 32".					
4	HON-4003CU10T	Black/Black	Black	29 lbs.	Each <del>313.00</del>
5	HON-4003CU22T	Frost/Frost	Black	29 lbs.	Each <del>312.00</del>
6	HON-4003CU19T	Iron Ore/Iron Ore	Black	29 lbs.	Each <del>313.00</del>
<b>D SLED BASE GUEST CHAIR</b>					
Supports up to 250 lbs. Seat: 20" x 18". Back: 21" x 15". Overall height: to 33".					
7	HON-4008CU10T	Black/Black	Black	33 lbs.	Each <del>340.00</del>
8	HON-4008CU22T	Frost/Frost	Black	33 lbs.	Each <del>347.00</del>
9	HON-4008CU19T	Iron Ore/Iron Ore	Black	33 lbs.	Each <del>340.00</del>



### ValuTask® Task Chairs & Stool

Designed to work well with standing height worksurfaces and tables.

- Double-layered seat cushions with a waterfall seat edge help increase leg circulation.
- Features center-tilt with lock and tension control for customizable comfort.
- Warranted for users up to 250 lbs.
- Backed by the HON Limited Five-Year Warranty.

ID No.	Seat/Back Color	Base Color	Shpg. Wt.	Unit	Price
<b>E LOW-BACK TASK CHAIR</b>					
Breathable sandwich mesh cushions with two layers of padding for increased comfort. Supports up to 250 lbs. Seat: 19.75" x 17.75". Back: 19.75" x 20.25". Overall height: 34.75" to 38.25".					
10	BSX-VL210MM10	Black/Black	Black	31 lbs.	Each <del>225.00</del>
<b>F ARMLESS TASK STOOL</b>					
Supports up to 250 lbs. Seat: 17" x 17". Back: 19" x 19". Overall height: 40" to 48".					
11	BSX-VL215MM10	Black/Black	Black	32 lbs.	Each <del>314.00</del>
<b>OPTIONAL HEIGHT ADJUSTABLE ARM KIT</b>					
Includes two black arms that can be easily added to the ValuTask® stools.					
12	BSX-VL995	Black		Each	<del>60.00</del>

### VL220 Mid-Back Task Chair

Corporate and comfortable! Smart, flexible design automatically adjusts to your every move.

- Lightweight frame and caster base promote freedom of movement in collaborative spaces.
- Contoured seat and back provide ergonomic support and comfort.
- Backed by the HON Limited Five-Year Warranty.

ID No.	Seat/Back Color	Base Color	Shpg. Wt.	Unit	Price
<b>G MID-BACK TASK CHAIR</b>					
Custom comfort with height-adjustable padded arms. Waterfall seat edge reduces pressure for improved circulation. Supports up to 250 lbs. Seat: 20" x 16.75". Back: 20.25" x 22.5". Overall height: 38.75" to 41".					
13	BSX-VL220VA10	Black/Black	Black	35 lbs.	Each <del>340.00</del>

For more information on additional chair features see page 80.







## Alera® Wrigley High-Performance Series

Designed with durability in mind and smart ergonomic features for comfort and performance.

- Waterfall seat edge reduces pressure points at the back of knees.
- Height- and width-adjustable padded arms.
- Ratcheting back/spine-support adjustability.
- Durable, fade-resistant fabric upholstery is tested for longevity.
- Impact-resistant molded plastic shell.
- Manufacturer's limited five-year warranty.
- Contains 5% post-consumer recycled content, 30% total recycled content.
- Meets or Exceeds ANSI/BIFMA Standards.

ID No.	Seat/Back Color	Base Color	Shpg. Wt.	Unit	Price
--------	-----------------	------------	-----------	------	-------

### A HIGH PERFORMANCE HIGH-BACK MULTIFUNCTION TASK CHAIR

Multifunction mechanism allows back and angle adjustment relative to the seat. Adjustable tilt/lock (free-floating and infinite locking positions). Supports up to 275 lbs. Seat: 20.88" x 19.5". Back: 18.88" x 25.38". Overall height: 43" to 46.88".

1	ALE-HPM4101	Black/Black	Black	69 lbs.	Each	<del>595.00</del>
---	-------------	-------------	-------	---------	------	-------------------

### B HIGH PERFORMANCE HIGH-BACK SYNCHRO-TILT TASK CHAIR

Synchro-tilt mechanism allows back to recline in a 2-to-1 ratio to the seat to help keep your feet on the ground even when leaning back. Supports up to 275 lbs. Seat: 20.88" x 19.5". Back: 18.88" x 25.38". Overall height: 41.38" to 45.25".

2	ALE-HPS4101	Black/Black	Black	52 lbs.	Each	<del>505.00</del>
---	-------------	-------------	-------	---------	------	-------------------

### C 24/7 HIGH PERFORMANCE HIGH-BACK MULTIFUNCTION TASK CHAIR

Supports up to 300 lbs. Seat: 20.88" x 19.5". Back: 25.38" x 28.88". Overall height: 42.88" to 46".

3	ALE-HPT4101	Black/Black	Black	71 lbs.	Each	<del>600.00</del>
---	-------------	-------------	-------	---------	------	-------------------

4	ALE-HPT4141	Gray/Gray	Black	71 lbs.	Each	<del>600.00</del>
---	-------------	-----------	-------	---------	------	-------------------

### D 24/7 HIGH PERFORMANCE MID-BACK MULTIFUNCTION TASK CHAIR

Enhanced support to withstand use through multiple shifts. Supports up to 300 lbs. Seat: 20.88" x 19.5". Back: 18.75" x 21.25". Overall height: 39.38" to 42.88".

5	ALE-HPT4201	Black/Black	Black	62 lbs.	Each	<del>620.00</del>
---	-------------	-------------	-------	---------	------	-------------------

6	ALE-HPT4241	Gray/Gray	Black	71 lbs.	Each	<del>620.00</del>
---	-------------	-----------	-------	---------	------	-------------------

### E HIGH PERFORMANCE MID-BACK SYNCHRO-TILT TASK CHAIR

Synchro-tilt mechanism allows back to recline in a 2-to-1 ratio to the seat to help keep your feet on the ground even when leaning back. Supports up to 275 lbs. Seat: 20.88" x 19.5". Back: 18.75" x 21.25". Overall height: 37" to 40.5".

7	ALE-HPS4201	Black/Black	Black	50 lbs.	Each	<del>445.00</del>
---	-------------	-------------	-------	---------	------	-------------------

### F HIGH PERFORMANCE MID-BACK MULTIFUNCTION TASK CHAIR

Multifunction mechanism allows back and angle adjustment relative to the seat. Adjustable tilt/lock (free-floating and infinite locking positions). Supports up to 275 lbs. Seat: 20.88" x 19.5". Back: 18.75" x 21.25". Overall height: 38.5" to 42.5".

8	ALE-HPM4201	Black/Black	Black	55 lbs.	Each	<del>530.00</del>
---	-------------	-------------	-------	---------	------	-------------------

## Wrigley Series



Black Fabric Gray Fabric



Gray Tweed



Gray Tweed

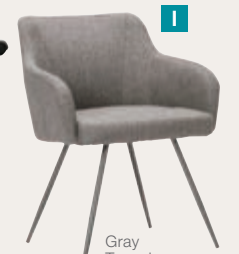

Gray Tweed

## Captain Series



Gray Tweed

## Alera® Captain Series

Modern captain's chairs with a commanding style.

- Make a statement at your desk or in the conference room.
- Cushioned seat and back with durable fabric upholstery.
- Contoured rounded back and arms for the perfect support.
- Extended seat edge to help reduce pressure points at the back of the knee.
- Chrome base.
- Manufacturer's limited five-year warranty.
- Contains 25% post-consumer recycled content, 30% total recycled content.
- Meets or Exceeds ANSI/BIFMA Standards.

ID No.	Seat/Back Color	Base Color	Shpg. Wt.	Unit	Price
--------	-----------------	------------	-----------	------	-------

### G HIGH-BACK CHAIR

Supports up to 275 lbs. Seat: 19.5" x 19.25". Back: 21.5" x 21.75". Overall height: 40.25" to 43.44".

9	ALE-CS4151	Gray Tweed/Gray Tweed	Chrome	34 lbs.	Each	<del>369.00</del>
---	------------	-----------------------	--------	---------	------	-------------------

### H MID-BACK CHAIR

Supports up to 275 lbs. Seat: 19.13" x 17.5". Back: 11.75" x 21.25". Overall height: 29.5" to 32.5".

10	ALE-CS4251	Gray Tweed/Gray Tweed	Chrome	30 lbs.	Each	<del>299.00</del>
----	------------	-----------------------	--------	---------	------	-------------------

### I GUEST CHAIR

Supports up to 275 lbs. Seat: 19.38" x 18.13". Back: 21.5" x 11.5". Overall height: to 30.25".

11	ALE-CS4351	Gray Tweed/Gray Tweed	Chrome	25 lbs.	Each	<del>249.00</del>
----	------------	-----------------------	--------	---------	------	-------------------

For more information on additional chair features see page 80.



Prices subject to change without notice. Visit our website for the latest pricing and product information.



**A**

Black Leather (SB11)



**B**

Shown with Optional T-Arms  
Black (GA10)



**C**

Navy Fabric (GA90)



**D**

Black (GA10)



**E**

Shown with Optional T-Arms  
Black Leather (SB11)



**F**

Black (GA10)



Black SofThread™ Leather (SB11)  
Black (GA10)  
Navy (GA90)

## HON Volt® Series

Great comfort. Great style. Great value.

- Fresh design with enhanced scale and function.
- Shaped seat and back with stylish covered back uprights.
- Generous proportions with a contoured back for optimal comfort.
- Five-star base with casters for mobility.
- Stain-resistant 100% polyester or leather upholstery.
- Backed by the HON Full Lifetime Warranty.
- Contains 3% pre-consumer recycled content, 38% post-consumer recycled content.
- Meets or Exceeds ANSI/BIFMA Standards and ISTA Performance Standards. ♻️ ♻️ ♻️



ID No.	Seat/Back Color	Base Color	Shpg. Wt.	Unit	Price
--------	-----------------	------------	-----------	------	-------

### A TASK CHAIR WITH SYNCHRO-TILT

Synchro-tilt allows back to recline at a 2-to-1 ratio to seat angle. Supports up to 250 lbs. Seat: 18.5" × 18.75". Back: 17.25" × 18.75". Overall height: 35.75" to 40". ① ④ ⑦

#### SofThread™ Leather

1	HON-5703SB11T	Black/Black	Black	29 lbs.	Each	<del>371.00</del>
---	---------------	-------------	-------	---------	------	-------------------

#### Fabric

2	HON-5703GA10T	Black/Black	Black	29 lbs.	Each	<del>341.00</del>
---	---------------	-------------	-------	---------	------	-------------------

### B MESH BACK TASK CHAIR WITH SYNCHRO-TILT

Breathable mesh back with stain-resistant polyester upholstery. Supports up to 250 lbs. Seat: 19.25" × 17.88". Back: 18" × 18.75". Overall height: 34.38" to 38.5". ① ④ ⑦

#### Fabric

3	HON-5713GA10T	Black/Black	Black	32 lbs.	Each	<del>455.00</del>
---	---------------	-------------	-------	---------	------	-------------------

ID No.	Seat/Back Color	Base Color	Shpg. Wt.	Unit	Price
--------	-----------------	------------	-----------	------	-------

### C TASK CHAIR

Supports up to 250 lbs. Seat: 18.5" × 18.75". Back: 17.25" × 18.75". Overall height: 35.75" to 40". ① ④

#### SofThread™ Leather

4	HON-5701SB11T	Black/Black	Black	29 lbs.	Each	<del>322.00</del>
---	---------------	-------------	-------	---------	------	-------------------

#### Fabric

5	HON-5701GA10T	Black/Black	Black	29 lbs.	Each	<del>292.00</del>
---	---------------	-------------	-------	---------	------	-------------------

6	HON-5701GA90T	Navy/Navy	Black	29 lbs.	Each	<del>292.00</del>
---	---------------	-----------	-------	---------	------	-------------------

### D MESH BACK FABRIC TASK CHAIR

Breathable mesh back and stain-resistant polyester upholstery. Supports up to 250 lbs. Seat: 19.25" × 18.75". Back: 18" × 18.75". Overall height: 34.63" to 38.75". ① ④

7	HON-5711GA10T	Black/Black	Black	29 lbs.	Each	<del>405.00</del>
---	---------------	-------------	-------	---------	------	-------------------

### E ARMLESS UPHOLSTERED BACK TASK STOOL

Adjustable footring for comfort and stability. Supports up to 275 lbs. Seat: 19" × 20". Back: 16.5" × 20". Overall height: 40.38" to 49.88". ①

#### SofThread™ Leather

8	HON-5705SB11T	Black/Black	Black	36 lbs.	Each	<del>510.00</del>
---	---------------	-------------	-------	---------	------	-------------------

#### Fabric

9	HON-5705GA10T	Black/Black	Black	36 lbs.	Each	<del>460.00</del>
---	---------------	-------------	-------	---------	------	-------------------

### F ARMLESS MESH BACK TASK STOOL

Breathable mesh back provides both an elegant look and maximum support. Adjustable footring for comfort and stability. Supports up to 275 lbs. Seat: 19" × 20". Back: 18" × 18.5". Overall height: 40.38" to 49.88". ① ④

10	HON-5715GA10T	Black/Black	Black	36 lbs.	Each	<del>597.00</del>
----	---------------	-------------	-------	---------	------	-------------------

ID No.	Color	Unit	Price
--------	-------	------	-------

### G OPTIONAL HEIGHT-ADJUSTABLE T-ARMS FOR HON VOLT SERIES CHAIRS

Deliver upper body and shoulder support and are easy to install.

11	HON-5795T	Black	Pair	<del>91.00</del>
----	-----------	-------	------	------------------

For more information on additional chair features see page 80.



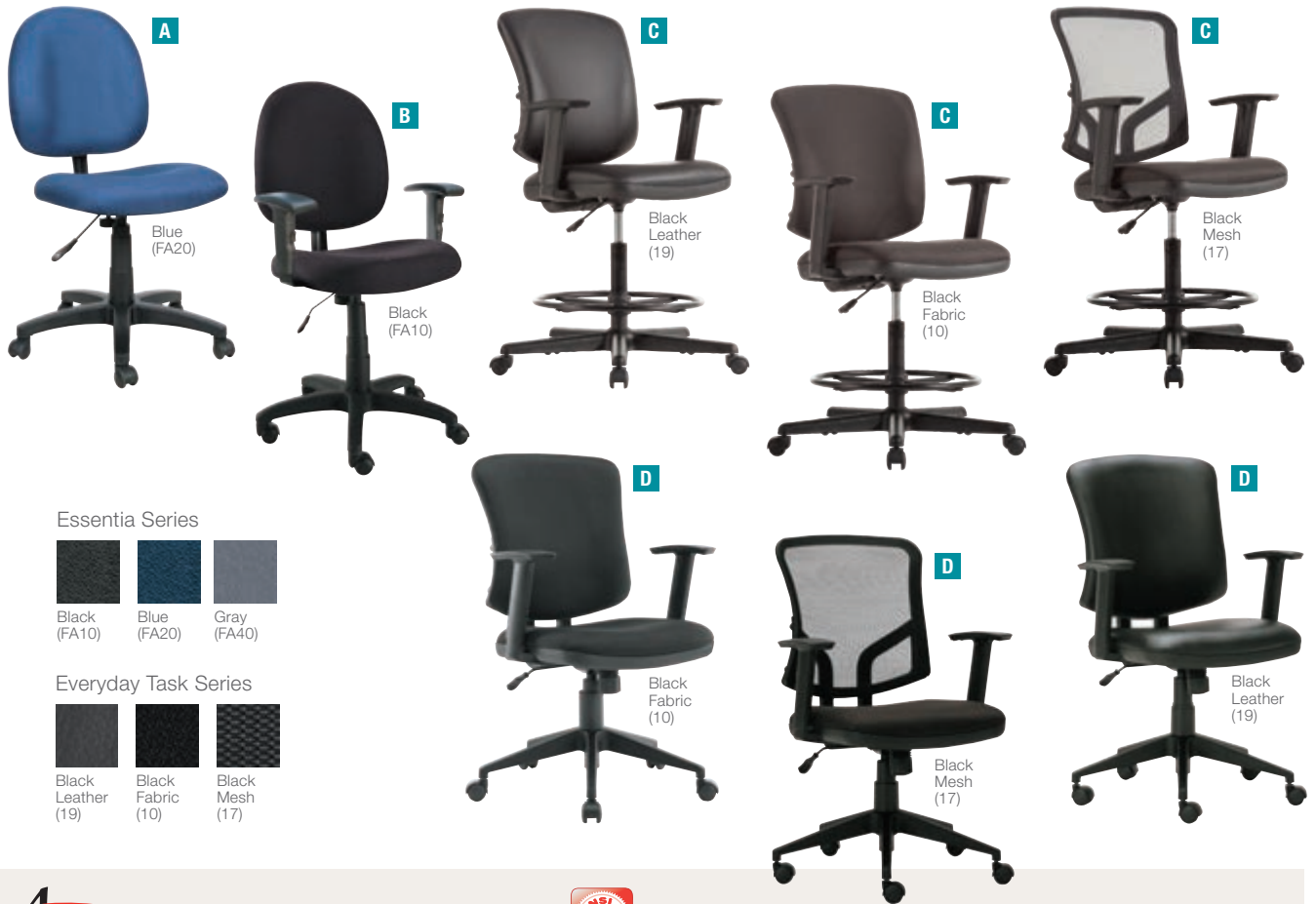

### Essentia Series

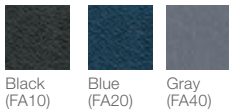

### Everyday Task Series

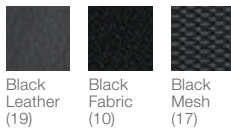

## Alera® Essentia Series

Contoured seat and back provide added comfort.

- Features back depth adjustment and rotates a full 360° in either direction for ease of motion.
- Black five-star base with casters.
- Optional Arms sold and shipped separately.
- Manufacturer's limited five-year warranty.
- Meets or Exceeds ANSI/BIFMA Standards. ♻️ ♻️ ♻️

ID No.	Seat/Back Color	Base Color	Shpg. Wt.	Unit	Price
--------	-----------------	------------	-----------	------	-------

### A SWIVEL TASK CHAIR

Supports up to 275 lbs. Seat: 19.25" x 18.13". Back: 17.88" x 18.13". Overall height: 36" to 41.13". ① ③

1	ALE-VT48FA10B	Black/Black	Black	28 lbs.	Each	<del>295.00</del>
2	ALE-VT48FA20B	Blue/Blue	Black	28 lbs.	Each	<del>295.00</del>
3	ALE-VT48FA40B	Gray/Gray	Black	28 lbs.	Each	<del>295.00</del>

### B SWIVEL TASK CHAIR WITH ADJUSTABLE ARMS

Supports up to 275 lbs. Seat: 19.25" x 18.13". Back: 17.88" x 18.13". Overall height: 36" to 41.13". ♻️ ♻️ ♻️ ① ③

4	ALE-VTA4810	Black/Black	Black	36 lbs.	Each	<del>299.00</del>
---	-------------	-------------	-------	---------	------	-------------------

For more information on additional chair features see page 80.



## Alera® Everyday Task Series

The one chair suitable for all your everyday work tasks.

- Contoured padded seat and back provides superior comfort and ergonomics.
- Waterfall seat edge relieves pressure on the back of legs and knees.
- Adjustable height padded arms.
- Manufacturer's limited five-year warranty.
- Contains 5% post-consumer recycled content, 20% total recycled content.
- Meets or Exceeds ANSI/BIFMA Standards. ♻️ ♻️ ♻️

ID No.	Seat/Back Color	Base Color	Shpg. Wt.	Unit	Price
--------	-----------------	------------	-----------	------	-------

### C STOOL

Adjustable foot rest for support and to keep feet from hanging. Supports up to 275 lbs. Seat: 18.88" x 18". Back: 18" x 18.5". Overall height: 38.75" to 47.5". ① ④

#### Leather

5	ALE-TE4619	Black/Black	Black	39 lbs.	Each	<del>375.00</del>
---	------------	-------------	-------	---------	------	-------------------

#### Fabric

6	ALE-TE4610	Black/Black	Black	39 lbs.	Each	<del>335.00</del>
---	------------	-------------	-------	---------	------	-------------------

#### Mesh

7	ALE-TE4617	Black/Black	Black	36 lbs.	Each	<del>399.00</del>
---	------------	-------------	-------	---------	------	-------------------

### D OFFICE CHAIR

Supports up to 275 lbs. Seat: 19" x 17.25". Back: 18" x 17.88". Overall height: 35.5" to 39.13". ① ④

#### Fabric

8	ALE-TE4810	Black/Black	Black	36 lbs.	Each	<del>249.00</del>
---	------------	-------------	-------	---------	------	-------------------

#### Mesh

9	ALE-TE4817	Black/Black	Black	31 lbs.	Each	<del>309.00</del>
---	------------	-------------	-------	---------	------	-------------------

#### Leather

10	ALE-TE4819	Black/Black	Black	36 lbs.	Each	<del>299.00</del>
----	------------	-------------	-------	---------	------	-------------------

Prices subject to change without notice.  
Visit our website for the latest pricing and product information.

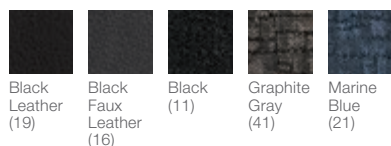
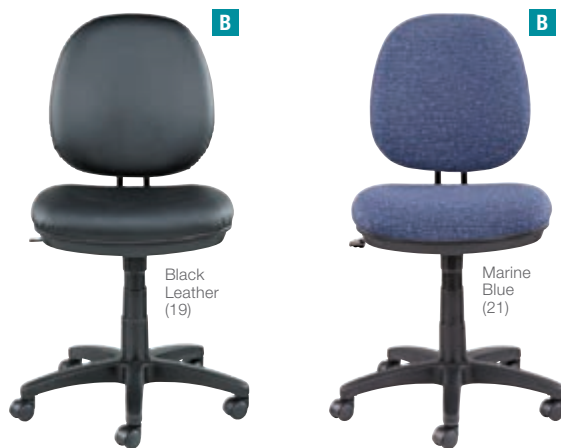

## Alera® Interval Series

**Compact and comfortable—Ideal for all-day seating in tight spaces.**

- Molded plastic, impact-resistant shell.
- Waterfall seat edge helps relieve pressure points on the underside of legs.
- Back height adjustment for optimal lumbar support.
- Durable upholstery designed to resist abrasions and fading.
- Optional Arms sold separately.
- Manufacturer's limited five-year warranty.
- Contains 25% pre-consumer recycled content, 5% post-consumer recycled content, 30% total recycled content.
- Meets or Exceeds ANSI/BIFMA Standards.

ID No.	Seat/Back Color	Base Color	Shpg. Wt.	Unit	Price
--------	-----------------	------------	-----------	------	-------

### A SWIVEL TASK STOOL

Adjustable footing for optimal feet positioning. Supports up to 275 lbs. Seat: 19.88" x 18.25". Back: 16.13" x 17.38". Overall height: 40.75" to 51.13". ① ②

#### Faux Leather

1	ALE-IN4616	Black/Black	Black	36 lbs.	Each	<del>329.00</del>
2	ALE-IN4611	Black/Black	Black	36 lbs.	Each	<del>329.00</del>
3	ALE-IN4641	Graphite Gray/Graphite Gray	Black	36 lbs.	Each	<del>329.00</del>
4	ALE-IN4621	Marine Blue/Marine Blue	Black	36 lbs.	Each	<del>329.00</del>

### B SWIVEL/TILT TASK CHAIR

Supports up to 275 lbs. Seat: 19.88" x 18.25". Back: 16.13" x 17.38". Overall height: 34.88" to 39.5". ① ② ④

#### Leather

5	ALE-IN4819	Black/Black	Black	31 lbs.	Each	<del>255.00</del>
6	ALE-IN4811	Black/Black	Black	31 lbs.	Each	<del>239.00</del>
7	ALE-IN4841	Graphite Gray/Graphite Gray	Black	31 lbs.	Each	<del>240.00</del>
8	ALE-IN4821	Marine Blue/Marine Blue	Black	31 lbs.	Each	<del>240.00</del>

ID No.	Seat/Back Color	Base Color	Shpg. Wt.	Unit	Price
--------	-----------------	------------	-----------	------	-------

### C SWIVEL/TILT MESH CHAIR

Supports up to 275 lbs. Seat: 19.88" x 18.25". Back: 16.13" x 17.38". Overall height: 34.88" to 39.5". ① ② ④

#### Leather

9	ALE-IN4815	Black/Black	Black	30 lbs.	Each	<del>265.00</del>
---	------------	-------------	-------	---------	------	-------------------

#### Fabric

10	ALE-IN4814	Black/Black	Black	30 lbs.	Each	<del>255.00</del>
----	------------	-------------	-------	---------	------	-------------------

ID No.	Color	Unit	Price
--------	-------	------	-------

### OPTIONAL FIXED HEIGHT T-ARMS

For Alera® Interval and Essentia Series Chairs. Stationary arms stay in place. Help reduce strain on neck and shoulders. Attach with ease. Soft PU Armcaps.

11	ALE-IN49AKB10B	Black	Pair	<del>75.00</del>
----	----------------	-------	------	------------------

### OPTIONAL HEIGHT-ADJUSTABLE T-ARMS

For Alera® Interval and Essentia Series Chairs. Help reduce strain on shoulders and neck. Adjustable for user's comfort. Easy installation. Soft PU Armcaps.

12	ALE-IN49AKA10B	Black	Pair	<del>87.00</del>
----	----------------	-------	------	------------------

For more information on additional chair features see page 80.

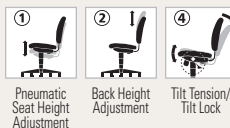





**A**

Black



**B**

Black



**C**

Iron Ore  
(CU19)



**D**

Frost  
(CU22)

VISIT US ONLINE FOR OUR FULL ASSORTMENT OF

Colors & Options



## 4-Oh-One & 4-Oh-Two Mid-Back Task Chairs

Pneumatic seat height adjustment and 360-degree swivel allows you to customize your comfort.

- Smooth-rolling casters and durable wheels hold up even under heavy use.
- Padded seat and back relieve pressure points and deliver long-lasting comfort.
- Sadie limited three-year warranty.
- Meets or Exceeds ISTA Performance Standards.

ID No.	Seat/Back Color	Base Color	Shpg. Wt.	Unit	Price
--------	-----------------	------------	-----------	------	-------

**A 4-OH-ONE ARMLESS MID-BACK TASK CHAIR**

Supports up to 250 lbs. Seat: 19.29" x 18.1". Back: 18.7" x 17.32". Overall height: to 37.8".

1	BSX-VST401	Black/Black	Black	25 lbs.	Each	<del>424.00</del>
---	------------	-------------	-------	---------	------	-------------------

**B 4-OH-TWO MID-BACK TASK CHAIR WITH ARMS**

Sculpted arms provide comfy all-day support for upper body and shoulders. Supports up to 250 lbs. Seat: 19.29" x 18.1". Back: 18.7" x 17.32". Overall height: 33.07" to 37.8".

2	BSX-VST402	Black/Black	Black	28 lbs.	Each	<del>434.00</del>
---	------------	-------------	-------	---------	------	-------------------



**E**

Iron Ore  
(CU19)



**F**

Shown with Optional Height-Adjustable T-Arms

Black  
(CU10)

**In-Stock**



Black  
(CU10)

Iron Ore  
(CU19)

**Special Order**

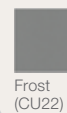

Frost  
(CU22)



Requires additional lead time and cannot be returned.



## ComforTask® Seating

For the all-day worker.

- Back height adjustment moves the back up or down to fit various body sizes.
- Oversized cushions for additional comfort.
- Solid construction ensures stability.
- Black base and frame.
- Backed by the HON Full Lifetime Warranty.
- Contains 38% post-consumer recycled content, 41% total recycled content.
- Level 2 Certified; Meets or Exceeds ANSI/BIFMA Standards and ISTA Performance Standards; SCS Indoor Advantage Gold Certified.

ID No.	Seat/Back Color	Base Color	Shpg. Wt.	Unit	Price
--------	-----------------	------------	-----------	------	-------

**C MULTI-TASK CHAIR**

Supports up to 300 lbs. Seat: 20" x 18". Back: 16" x 20". Overall height: 36" to 41".

3	HON-5903CU10T	Black/Black	Black	32 lbs.	Each	<del>441.00</del>
4	HON-5903CU19T	Iron Ore/Iron Ore	Black	32 lbs.	Each	<del>441.00</del>
5	HON-5903CU22T	Frost/Frost	Black	32 lbs.	Each	<del>434.00</del>



For more information on additional chair features see page 80.

ID No.	Seat/Back Color	Base Color	Shpg. Wt.	Unit	Price
--------	-----------------	------------	-----------	------	-------

**D TASK CHAIR**

Supports up to 300 lbs. Seat: 20" x 18". Back: 16" x 21". Overall height: 35" to 40".

6	HON-5902CU10T	Black/Black	Black	30 lbs.	Each	<del>312.00</del>
7	HON-5902CU19T	Iron Ore/Iron Ore	Black	30 lbs.	Each	<del>312.00</del>

**With Tilt Lock/Tilt Tension**

8	HON-5902CU22T	Frost/Frost	Black	30 lbs.	Each	<del>307.00</del>
---	---------------	-------------	-------	---------	------	-------------------

**E TASK SWIVEL CHAIR**

Supports up to 300 lbs. Seat: 20" x 18". Back: 16" x 18". Overall height: 34" to 38".

9	HON-5901CU10T	Black/Black	Black	30 lbs.	Each	<del>294.00</del>
10	HON-5901CU19T	Iron Ore/Iron Ore	Black	30 lbs.	Each	<del>294.00</del>

**With Seat Glide Mechanism**

11	HON-5901CU22T	Frost/Frost	Black	30 lbs.	Each	<del>288.00</del>
----	---------------	-------------	-------	---------	------	-------------------

**F TASK STOOL WITH ADJUSTABLE FOOTRING**

Supports up to 300 lbs. Seat: 20" x 18". Back: 16" x 18". Overall height: 40" to 50".

12	HON-5905CU10T	Black/Black	Black	34 lbs.	Each	<del>427.00</del>
13	HON-5905CU22T	Frost/Frost	Black	34 lbs.	Each	<del>419.00</del>
14	HON-5905CU19T	Iron Ore/Iron Ore	Black	34 lbs.	Each	<del>427.00</del>

ID No.	Color	Unit	Price
--------	-------	------	-------

**OPTIONAL HEIGHT-ADJUSTABLE T-ARMS FOR HON COMFORTASK CHAIRS**

Adjust for one's comfort level. Help reduce stress on neck and shoulders. Durable construction for added strength.

15	HON-5995T	Black	Pair	<del>440.00</del>
----	-----------	-------	------	-------------------

**OPTIONAL FIXED T-ARMS FOR HON COMFORTASK CHAIRS**

Fixed arms remain in place. Help reduce strain on neck and shoulders. Heavy-duty construction provides strength and durability.

16	HON-5991T	Black	Pair	<del>77.00</del>
----	-----------	-------	------	------------------

# Seating Stools



**HON.**



## Prominent™ Mesh Stool

Breathable woven mesh back conforms to the upper body for added support.

- Contoured, breathable mesh seat cushion features two layers of padding for greater comfort.
- Frame and five-star base are molded from fiberglass-reinforced resin for increased durability.
- Adaptable design for professional, administrative and technology functions as well as meeting workspaces.
- Backed by the HON Limited Five-Year Warranty.

ID No.	Color	Shpg. Wt.	Unit	Price
<b>A MESH HIGH-BACK TASK STOOL</b>				
Supports up to 250 lbs. Seat: 20.5" × 17.1". Back: 17.1" × 22.8". Overall height: 42.9" to 50".				
1	HON-VL539MM10	Black	44 lbs.	Each <del>350.00</del>

## ValuTask® Task Stool

Designed to work well with standing height worksurfaces and tables.

- Double-layered seat cushions with a waterfall seat edge help increase leg circulation.
- Features center-tilt with lock and tension control for customizable comfort.
- Warranted for users up to 250 lbs.
- Backed by the HON Limited Five-Year Warranty.

ID No.	Color	Shpg. Wt.	Unit	Price
<b>B ARMLESS TASK STOOL</b>				
Supports up to 250 lbs. Seat: 17" × 17". Back: 19" × 19". Overall height: 40" to 48".				
2	BSX-VL215MM10	Black	32 lbs.	Each <del>344.00</del>
<b>OPTIONAL HEIGHT ADJUSTABLE ARM KIT</b>				
Includes two black arms that can be easily added to the ValuTask® stools.				
3	BSX-VL995	Black		Each <del>00.00</del>

## Torch™ Task Stool

Designed to work well with standing height worksurfaces and tables.

- Waterfall seat edge promotes better leg circulation.
- Generous foam seat cushion provides plush comfort and reduces pressure points.
- Fixed arms provide shoulder and neck support.
- Large scale seat and back accommodate a wider variety of users.
- Warranted for users up to 250 lbs.
- Backed by the HON Limited Five-Year Warranty.

ID No.	Color	Shpg. Wt.	Unit	Price
<b>C VL515 MESH BACK TASK STOOL WITH FIXED ARMS</b>				
Supports up to 250 lbs. Seat: 19" × 18". Back: 20" × 20". Overall height: 43" to 52".				
4	BSX-VL515LH10	Black	40 lbs.	Each <del>003.00</del>

## Volt® Series

Great comfort. Great style. Great value.

- Fresh design with enhanced scale and function.
- Shaped seat and back with stylish covered back uprights.
- Generous proportions with a contoured back for optimal comfort.
- Five-star base with casters for mobility.
- Stain-resistant 100% polyester or leather upholstery.
- Backed by the HON Full Lifetime Warranty.
- Contains 3% pre-consumer recycled content, 38% post-consumer recycled content.

ID No.	Color	Shpg. Wt.	Unit	Price
<b>D ARMLESS UPHOLSTERED MESH BACK TASK STOOL</b>				
Adjustable footring for comfort and stability. Supports up to 275 lbs. Seat: 19" × 20". Back: 16.5" × 20". Overall height: 40.38" to 49.88".				
<b>SofThread™ Leather</b>				
5	HON-5705SB11T	Black	36 lbs.	Each <del>510.00</del>
<b>Fabric</b>				
6	HON-5705GA10T	Black	36 lbs.	Each <del>400.00</del>
<b>E ARMLESS MESH BACK TASK STOOL</b>				
Breathable mesh back provides both an elegant look and maximum support. Adjustable footring for comfort and stability. Supports up to 275 lbs. Seat: 19" × 20". Back: 18" × 18.5". Overall height: 40.38" to 49.88".				
<b>OPTIONAL HEIGHT-ADJUSTABLE T-ARMS FOR HON VOLT SERIES CHAIRS</b>				
Deliver upper body and shoulder support and are easy to install.				
7	HON-5715GA10T	Black	36 lbs.	Each <del>597.00</del>
<b>OPTIONAL HEIGHT-ADJUSTABLE T-ARMS FOR HON VOLT SERIES CHAIRS</b>				
8	HON-5795T	Black		Pair <del>94.00</del>

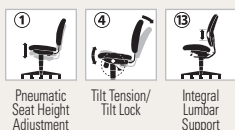

For more information on additional chair features see page 80.

## Interval Series

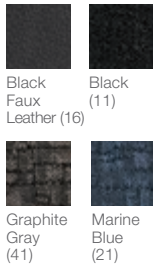

**A**

Black (11)



Marine Blue (21)



**B**

Black Mesh

## Etros



Black Mesh

## Elusion™



Black



**C**

Black



## Interval Series

**Compact and comfortable—ideal for all-day seating in tight spaces.**

- Molded plastic, impact-resistant shell.
- Waterfall seat edge helps relieve pressure points on the underside of legs.
- Back height adjustment for optimal lumbar support.
- Durable upholstery designed to resist abrasions and fading.
- Optional Arms sold separately.
- Manufacturer's limited five-year warranty.
- Contains 25% pre-consumer recycled content, 5% post-consumer recycled content, 30% total recycled content.
- Meets or exceeds ANSI/BIFMA Standards.

ID No.	Color	Shpg. Wt.	Unit	Price
--------	-------	-----------	------	-------

### **A** SWIVEL TASK STOOL

Adjustable footring for optimal feet positioning. Supports up to 275 lbs. Seat: 19.88" x 18.25". Back: 16.13" x 17.38". Overall height: 40.75" to 51.13". <sup>①</sup> <sup>②</sup>

#### Faux Leather

1	ALE-IN4616	Black	36 lbs.	Each	<del>329.00</del>
---	------------	-------	---------	------	-------------------

#### Fabric

2	ALE-IN4611	Black	36 lbs.	Each	<del>329.00</del>
3	ALE-IN4641	Graphite Gray	36 lbs.	Each	<del>329.00</del>
4	ALE-IN4621	Marine Blue	36 lbs.	Each	<del>329.00</del>

### OPTIONAL HEIGHT-ADJUSTABLE T-ARMS

For Alera® Interval and Essentia Series Chairs. Help reduce strain on shoulders and neck. Adjustable for user's comfort. Easy installation. Soft PU Armcaps.

5	ALE-IN49AKA10B	Black		Pair	<del>67.00</del>
---	----------------	-------	--	------	------------------

### OPTIONAL FIXED HEIGHT T-ARMS

For Alera® Interval and Essentia Series Chairs. Stationary arms stay in place. Help reduce strain on neck and shoulders. Attach with ease. Soft PU Armcaps.

6	ALE-IN49AKB10B	Black		Pair	<del>75.00</del>
---	----------------	-------	--	------	------------------

\* ALE-IN4616, ALE-IN4611, ALE-IN4641, ALE-IN4621—Optional Arms sold and shipped separately.

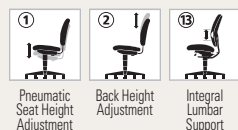

For more information on additional chair features see page 80.

## Etros Series

**An economical choice for mesh comfort.**

- Breathable mesh back with cushioned mesh fabric seat.
- Adjustable lumbar support.
- Five-star base with casters for easy mobility.
- Manufacturer's limited five-year warranty.
- Contains 5% post-consumer recycled content, 30% total recycled content.
- Meets or exceeds ANSI/BIFMA Standards.

ID No.	Color	Shpg. Wt.	Unit	Price
--------	-------	-----------	------	-------

### **B** HEIGHT ADJUSTABLE MESH STOOL

Height adjustable footring for optimal foot positioning. Supports up to 275 lbs. Seat: 20.88" x 19.88". Back: 18.88" x 20.63". Overall height: 44.88" to 54.75". <sup>①</sup> <sup>②</sup>

7	ALE-ET4614	Black	40 lbs.	Each	<del>465.00</del>
---	------------	-------	---------	------	-------------------

## Elusion® Series

**Clean, classic styling complements the busy office environment.**

- Contoured seat cushion with waterfall edge to help relieve pressure on legs.
- Height- and width-adjustable arms with soft polyurethane pads.
- Five-star base with casters for easy mobility.
- Breathable mesh back for all day support.
- Height adjustable ratchet back for optimal lumbar support.
- Manufacturer's limited five-year warranty.
- Contains 5% post-consumer recycled content, 15% total recycled content.
- Meets or exceeds ANSI/BIFMA Standards.

ID No.	Color	Shpg. Wt.	Unit	Price
--------	-------	-----------	------	-------

### **C** MESH STOOL

Ergonomically designed stool adjusts to fit multiple users. Adjustable foot ring for leg support. Supports up to 275 lbs. Seat: 20.5" x 21". Back: 20.13" x 20.13". Overall height: 42.13" to 51.63". <sup>①</sup> <sup>②</sup>

8	ALE-EL4614	Black	53 lbs.	Each	<del>505.00</del>
---	------------	-------	---------	------	-------------------

# Seating Stools

## Apprentice II



Black (BL)



**A** Shown with Adjustable T-Pad Arms

## Reve™ Series



Black (BL)



**B**

Black Mesh

## Everyday Task Stool



Black Leather



Black Fabric



Black Mesh



**C**

Black Leather



**C**

Black Fabric



**C**

Black Mesh/Fabric

## Ignition® Series



Black



**D**

Black



## Apprentice II Extended-Height Chair

Ergonomic features of this chair help support the body.

- Sculpted foam seat and back cushions for superior ergonomic comfort.
- Waterfall seat edge may help support better circulation in the legs.
- Easy-care vinyl for long wear.
- Footring allows legs to rest and may help alleviate pressure points in the legs.
- Manufacturer's limited lifetime warranty.
- GREENGUARD Certified; Meets or exceeds ANSI/BIFMA Standards.

ID No.	Color	Shpg. Wt.	Unit	Price
--------	-------	-----------	------	-------

### **A** EXTENDED HEIGHT CHAIR

Supports up to 250 lbs.  
Seat: 20½" × 19". Back: 18½" × 19". Overall height: 44½" to 54".

1	SAF-7084BL	Black	42 lbs.	Each	549.00
---	------------	-------	---------	------	--------

### ADJUSTABLE T-PAD ARMS

Add these optional T-pad arms to your favorite Apprentice Series chair for additional support and to help reduce strain on neck and shoulders. Easy pushbutton height adjustment creates custom comfort for a variety of users.

2	SAF-6689BL	Black		Pair	110.00
---	------------	-------	--	------	--------

## Reve™ Series

Seating that can be used throughout a workspace to create a cohesive look and feel.

- Contoured back provides lumbar support.
- Accented with a silver frame.
- Manufacturer's limited lifetime warranty.

ID No.	Color	Shpg. Wt.	Unit	Price
--------	-------	-----------	------	-------

### **B** MESH EXTENDED-HEIGHT CHAIR

Supports up to 250 lbs.  
Seat: 18" × 17½". Back: 18½" × 15". Overall height: 39" to 49".

3	SAF-6820BL	Black	32 lbs.	Each	599.00
---	------------	-------	---------	------	--------

For more information on additional chair features see page 80.

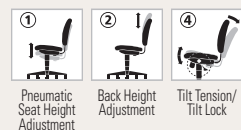

Pneumatic Seat Height Adjustment

Back Height Adjustment

Tilt Tension/Tilt Lock



## Everyday Task Stool

The one stool suitable for all your everyday work tasks.

- Contoured padded seat and back provides superior comfort and ergonomics.
- Waterfall seat edge relieves pressure on the back of legs and knees.
- Adjustable height padded arms.
- Adjustable foot rest for support and to keep feet from hanging.
- Manufacturer's limited five-year warranty.
- Contains 5% post-consumer recycled content, 20% total recycled content.
- Meets or exceeds ANSI/BIFMA Standards.

ID No.	Color	Shpg. Wt.	Unit	Price
--------	-------	-----------	------	-------

### **C** EVERYDAY TASK STOOL

Supports up to 275 lbs.  
Seat: 19" × 17¼". Back: 18" × 17½". Overall height: 41¼" to 51¼".

<b>Leather</b>					
4	ALE-TE4619	Black	39 lbs.	Each	375.00
<b>Fabric</b>					
5	ALE-TE4610	Black	39 lbs.	Each	335.00
<b>Mesh</b>					
6	ALE-TE4617	Black	36 lbs.	Each	309.00



## Ignition® Series Seating

Ignition® addresses the needs of the total office with executive, work, task and guest seating solutions.

- Breathable mesh back offers comfort and support.
- Easily mobile on four dual-wheel casters.
- Backed by the HON Full Lifetime Warranty.
- Level 2 Certified; Meets or exceeds ANSI/BIFMA and ISTA Performance Standards; SCS Indoor Advantage Gold Certified.

ID No.	Color	Shpg. Wt.	Unit	Price
--------	-------	-----------	------	-------

### **D** FABRIC BACK TASK STOOL

Footring adjusts seven inches to accommodate user's leg length. Back height adjustment moves the back up or down to fit various body sizes. Height- and width-adjustable arms for personalized comfort. Supports up to 300 lbs.  
Seat: 19" × 16". Back: 18" × 22". Overall height: 43" to 53".

7	HON-IT109CU10	Black	57 lbs.	Each	762.00
---	---------------	-------	---------	------	--------

\* HON-IT109CU10—Contains 55% post-consumer recycled content, 58% total recycled content.





## Precision Extended-Height Swivel Stools

Economical drafting-height chair with durable upholstery.

- Adjustable footring supports legs to help ease pressure points.
- One-touch, pneumatic seat height control, manual back height and depth adjustment and 4" deep seat cushion to help support individual comfort and ease pressure points.
- Deep cushions provide maximum comfort.
- Five-star, 25" base features dual hooded casters.
- Manufacturer's limited lifetime warranty.
- GREENGUARD Certified; Meets or Exceeds ANSI/BIFMA Standards.

ID No.	Color	Shpg. Wt.	Unit	Price
<b>A EXTENDED HEIGHT SWIVEL STOOL WITH ADJUSTABLE FOOTRING</b>				
Supports up to 250 lbs. Seat: 17.75" x 16". Back: 16.25" x 14". Overall height: 42" to 54".				

Vinyl				
1	SAF-3406BL	Black	33 lbs.	Each <del>405.00</del>
Fabric				
2	SAF-3401BL	Black	33 lbs.	Each <del>405.00</del>

## Metro™ Chair Collection

Extended-height chair has form-fitting contoured back.

- Thick cushions offer comfort.
- Large, 26", five-star, aluminum base for added stability.
- Swivel tilt mechanism with adjustable tilt tension that may help prevent fatigue and ease pressure points in the legs.
- Two-tone dual wheel carpet casters for easy mobility.
- Manufacturer's limited lifetime warranty.
- GREENGUARD Certified.

ID No.	Color	Shpg. Wt.	Unit	Price
<b>B EXTENDED HEIGHT CHAIR</b>				
Supports up to 250 lbs. Seat: 18.25" x 17". Back: 17.5" x 16". Overall height: 39" to 49".				

Vinyl				
3	SAF-3442BV	Black Vinyl	35 lbs.	Each <del>404.00</del>
Fabric				
4	SAF-3442BL	Black	35 lbs.	Each <del>404.00</del>

**OPTIONAL HEIGHT-ADJUSTABLE T-PAD ARMS**  
Offer multiple adjustments for supreme comfort. Help reduce strain on neck and shoulders. Install with ease.

5	SAF-3495BL	Black/Chrome	Pair	<del>99.00</del>
---	------------	--------------	------	------------------

## Vue™ Series

Perfect for a photo studio, drafting table or for use with standing-height desks.

- Ergonomic, breathable nylon mesh back is shaped for all-day comfort.
- Provides ample support and may help prevent fatigue.
- Back-height adjustability helps support correct posture to potentially alleviate related back problems.
- Manufacturer's limited lifetime warranty.
- Meets or Exceeds ANSI/BIFMA Standards.

ID No.	Color	Shpg. Wt.	Unit	Price
--------	-------	-----------	------	-------

**C HEAVY-DUTY EXTENDED HEIGHT 24/7 STOOL**  
Rated for 24/7 use. Adjustable footring to help ease pressure points on legs. Optional T-Pad Arms sold separately. Supports up to 350 lbs. Seat: 20.5" x 20". Back: 18.75" x 18". Overall height: 37" to 54".

Vinyl				
6	SAF-3394BV	Black	54 lbs.	Each <del>619.00</del>
Fabric				
7	SAF-3394BL	Black	54 lbs.	Each <del>619.00</del>

**OPTIONAL T-PAD ADJUSTABLE ARMS FOR SAFCO® VUE™ 24/7 TASK CHAIR**  
Offer a relaxing work environment by adding support to your Vue™ task chairs. Multiple height and width adjustments provide extreme comfort levels to each user. Manufacturer's limited lifetime warranty.

8	SAF-3399BL	Black	Pair	<del>96.00</del>
---	------------	-------	------	------------------

**D MESH EXTENDED HEIGHT CHAIR**  
Perfect for a photo studio, drafting table or use with a standing-height desk. Breathable mesh back design adds comfort to the workday or makes an attractive addition in meeting spaces. Solid construction. Adjustable footring provides comfort and stability and help support better circulation in the legs. Ergonomic, height-adjustable seat may help prevent fatigue. Supports up to 250 lbs. Seat: 18" x 17.5". Back: 17" x 15.5". Overall height: 39.5" to 49.5".

Vinyl				
9	SAF-3395BV	Black	35 lbs.	Each <del>399.00</del>
Fabric				
10	SAF-3395BL	Black	35 lbs.	Each <del>399.00</del>

**OPTIONAL LOOP ARM KIT**  
Optional loop arm kit for Vue mesh extended-height chair.

11	SAF-3396BL	Black	Pair	<del>82.00</del>
----	------------	-------	------	------------------



For more information on additional chair features see page 80.

# Seating 24/7 & Stools



Wrigley Series



VISIT US ONLINE FOR OUR FULL ASSORTMENT OF  
**Colors & Options**



Ignition®  
Chair  
Black



Ignition® 2.0  
Black  
(C10)

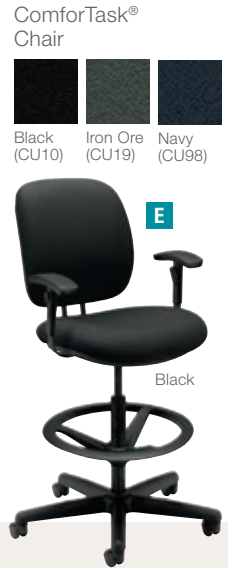

ComforTask®  
Chair

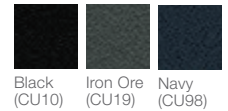

## Alera® Wrigley 24/7 Series

Enhanced support to withstand use through multiple shifts.

- Stronger mechanism for heavy-duty 24/7 use allows back angle adjustment relative to seat, adjustable tilt (free floating or infinite locking positions) and forward tilt.
- Waterfall seat edge relieves pressure on legs.
- Padded slant T-arms are height- and width-adjustable for extra comfort.
- Durable fabric upholstery, impact-resistant molded black plastic shell and black steel five-star base with casters for easy mobility.
- Manufacturer's limited five-year warranty.
- Meets or Exceeds ANSI/BIFMA Standards.



ID No.	Seat/Back Color	Base Color	Shpg. Wt.	Unit	Price
--------	-----------------	------------	-----------	------	-------

### A 24/7 HIGH PERFORMANCE HIGH-BACK MULTIFUNCTION TASK CHAIR

Supports up to 300 lbs. Seat: 20.88" x 19.5". Back: 25.38" x 28.88". Overall height: 42.88" to 46".

1	ALE-HPT4101	Black/ Black	Black	71 lbs.	Each	<del>699.00</del>
2	ALE-HPT4141	Gray/ Gray	Black	71 lbs.	Each	<del>699.00</del>

### B 24/7 HIGH PERFORMANCE MID-BACK MULTIFUNCTION TASK CHAIR

Enhanced support to withstand use through multiple shifts. Supports up to 300 lbs. Seat: 20.88" x 19.5". Back: 18.75" x 21.25". Overall height: 39.38" to 42.88".

3	ALE-HPT4201	Black/ Black	Black	62 lbs.	Each	<del>629.00</del>
4	ALE-HPT4241	Gray/ Gray	Black	71 lbs.	Each	<del>629.00</del>



## Ignition® Seating

Ignition addresses the needs of the total office with executive, work, task and guest seating solutions.

- Contoured seat and back reduce pressure points.
- Height- and width-adjustable arms provide a custom fit.
- Backed by the HON Full Lifetime Warranty.
- Contains 41% post-consumer recycled content, 45% total recycled content.
- Level 2 Certified; Meets or Exceeds ANSI/BIFMA Standards and ISTA Performance Standards; SCS Indoor Advantage Gold Certified.



ID No.	Seat/Back Color	Base Color	Shpg. Wt.	Unit	Price
--------	-----------------	------------	-----------	------	-------

### C MESH TASK STOOL

Supports up to 300 lbs. Seat: 19" x 16". Back: 18" x 24". Overall height: 46" to 55".

5	HON-IT108CU10	Black/ Black	Black	54 lbs.	Each	<del>762.00</del>
---	---------------	--------------	-------	---------	------	-------------------

## Ignition® 2.0 Seating

Ignition fits anyone, any task, any space.

- Adjustable lumbar support.
- 4-way stretch mesh enhanced mesh provides optimal comfort.
- Height- and width-adjustable arms provide a custom fit.
- Limited synchro-tilt with tension and lock puts you in control of your posture and comfort.
- Backed by the HON Full Lifetime Warranty.
- Contains 42% post-consumer recycled content, 45% total recycled content
- Level 2 Certified; Meets or Exceeds ANSI/BIFMA Standards and ISTA Performance Standards; SCS Indoor Advantage Gold Certified.

ID No.	Seat/Back Color	Base Color	Shpg. Wt.	Unit	Price
--------	-----------------	------------	-----------	------	-------

### D ILIRA®-STRETCH MESH BACK TASK STOOL

Features adjustable lumbar support, height- and width-adjustable arms as well as a foot ring and five-star base with casters. Easy assembly. Supports up to 300 lbs. Seat: 19" x 16". Back: 18" x 26". Overall height: 45" to 53".

6	HON-I2S1AMLC10T	Black/ Black	Black	51 lbs.	Each	<del>696.00</del>
---	-----------------	--------------	-------	---------	------	-------------------

## ComforTask® Seating

For the all-day worker.

- Back height adjustment moves the back up or down to fit various body sizes.
- Oversized cushions for additional comfort.
- Solid construction ensures stability.
- Black base and frame.
- Backed by the HON Full Lifetime Warranty.
- Contains 38% post-consumer recycled content, 39% total recycled content.
- Level 2 Certified; Meets or Exceeds ANSI/BIFMA Standards and ISTA Performance Standards; SCS Indoor Advantage Gold Certified.

ID No.	Seat/Back Color	Base Color	Shpg. Wt.	Unit	Price
--------	-----------------	------------	-----------	------	-------

### E TASK STOOL WITH ADJUSTABLE FOOTRING

Supports up to 300 lbs. Seat: 20" x 18". Back: 16" x 18". Overall height: 40" to 50".

7	HON-5905CU10T	Black/ Black	Black	34 lbs.	Each	<del>427.00</del>
8	HON-5905CU19T	Iron Ore/Iron Ore	Black	34 lbs.	Each	<del>427.00</del>
9	HON-5905CU98T	Navy/Navy	Black	34 lbs.	Each	<del>427.00</del>

ID No.	Color	Unit	Price
--------	-------	------	-------

### OPTIONAL HEIGHT-ADJUSTABLE T-ARMS FOR HON COMFORTASK CHAIRS

Adjust for one's comfort level. Help reduce stress on neck and shoulders. Durable construction for added strength.

10	HON-5995T	Black	Pair	<del>440.00</del>
----	-----------	-------	------	-------------------

For more information on additional chair features see page 80.





## Workshop Stools & Chairs

Designed for rugged environments.

- Ideal for workshops, assembly areas and manufacturing environments.
- Pneumatic seat height adjustment.
- Manufacturer's limited one-year warranty.
- Meets or Exceeds ANSI/BIFMA X5.1.

ID No.	Seat/Back Color	Base Color	Shpg. Wt.	Unit	Price
--------	-----------------	------------	-----------	------	-------

### A WORKBENCH SHOP CHAIR

Supports up to 300 lbs. Seat: 17¾" × 17". Back: 16¾" × 11¼". Overall height: 36¾" to 44".

1	SSX-1010301	Black	Black	39 lbs.	Each	485.05
2	SSX-1010275	Black	Black	35 lbs.	Each	399.95

### B PNEUMATIC SIT-STAND STOOL

Supports up to 250 lbs. Seat: 14¼" × 9". Overall height: 21" to 31".

3	SSX-1010276	Black	Black	19 lbs.	Each	456.95
---	-------------	-------	-------	---------	------	--------

### C TOOL TROLLEY WITH REMOVABLE TRAYS

Supports up to 250 lbs. Seat: 16" dia. × 3½" H. Back: 12" × 6". Overall height: 29½" to 33½".

4	SSX-1010277	Black	Black	25 lbs.	Each	495.95
---	-------------	-------	-------	---------	------	--------

### D HEAVY-DUTY SHOP STOOL

Supports up to 300 lbs. Seat: 14" dia. × 3½" H. Back: 12" × 6". Overall height: 41½" to 46½".

5	SSX-3010002	Black	Chrome	27 lbs.	Each	320.95
---	-------------	-------	--------	---------	------	--------

### E PRODUCTION CHAIR

Seat adjusts from 22" to 32". Supports up to 300 lbs. Seat: 18" × 16½". Back: 16½" × 15½". Overall height: 38¾" to 48¾".

6	SSX-1010014	Black	Black	45 lbs.	Each	594.95
---	-------------	-------	-------	---------	------	--------

\* SSX-1010301—Includes adjustable tooltray.  
SSX-1010275—Includes adjustable footing.



For more information on additional chair features see page 80.

## Lab & Healthcare Chairs & Stools

Designed specifically for lab and healthcare markets.

- Fuses comfort, stability and durability.
- Antimicrobial wipe-clean vinyl seat and back.
- Dual post back design.
- Chrome steel base for durability.
- Casters for mobility.
- Manufacturer's limited one-year warranty.
- Meets or Exceeds ANSI/BIFMA X5.1.

ID No.	Seat/Back Color	Base Color	Shpg. Wt.	Unit	Price
--------	-----------------	------------	-----------	------	-------

### F LAB AND HEALTHCARE STOOL

Supports up to 300 lbs. Seat: 16" dia. × 3" H. Back: 12" × 6". Overall height: 33" to 41".

7	SSX-3010011	Black	Chrome	25 lbs.	Each	364.95
---	-------------	-------	--------	---------	------	--------

### G LAB AND HEALTHCARE SEATING

Dual post arms provides superior comfort. Supports up to 300 lbs. Seat: 18½" × 16½". Back: 17" × 15". Overall height: 41" to 48".

8	SSX-1010296	White	Chrome	30 lbs.	Each	399.95
---	-------------	-------	--------	---------	------	--------



## WL Series Work Stool

Perfect for workbench, service desk and work table use in industrial, commercial and educational environments.

- Height adjustable seat with waterfall contours.
- Large contoured back is adjustable up, down, in and out
- Wipe-friendly seat and back.
- Self-sealing seat and back.
- Manufacturer's limited five-year warranty.
- Meets or exceeds ANSI/BIFMA Standards.

ID No.	Color	Shpg. Wt.	Unit	Price
--------	-------	-----------	------	-------

### H WL WORKBENCH STOOL

Supports up to 250 lbs. Seat: 16" × 16". Back: 15" × 12½". Overall height: 17½" to 25".

9	ALE-CS616	Black	28 lbs.	Each	324.45
---	-----------	-------	---------	------	--------

Prices subject to change without notice.  
Visit our website for the latest pricing and product information.

# Seating Stools

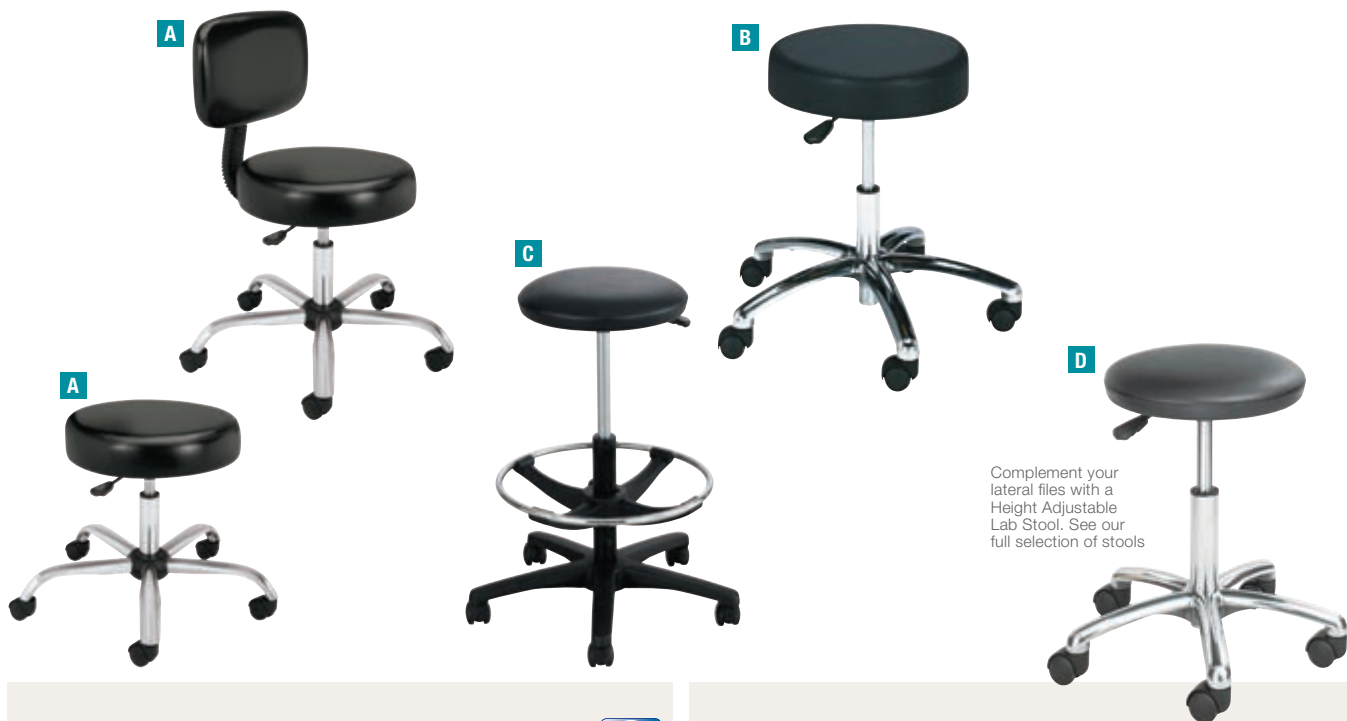

Complement your lateral files with a Height Adjustable Lab Stool. See our full selection of stools

**HON.**

## Adjustable Task/Lab Stool

Anti-microbial upholstery makes this stool ideal for use by healthcare providers in exam rooms.

- Height-adjustable for each user's comfort.
- Anti-microbial upholstery wipes clean with ease.
- Backed by the HON Full Lifetime Warranty.
- Meets or exceeds ANSI/BIFMA and ISTA Performance Standards.



ID No.	Color	Shpg. Wt.	Unit	Price
<b>A ADJUSTABLE TASK/LAB STOOL</b>				
Supports up to 250 lbs. Back: 15½" x 10". Overall height: 31½" to 38". <sup>①</sup> <sup>②</sup> <sup>③</sup>				
<b>With Back</b> —Seat: 16" Dia.				
1	HON-MTS11EA11 Black	27 lbs.	Each	<del>490.00</del>
<b>Without Back</b> —Seat: 16" Dia.				
2	HON-MTS01EA11 Black	20 lbs.	Each	<del>367.00</del>

## Extended-Height Lab Stools

Durable and comfortable, ideal for any environment.

- Pneumatic height adjustment.
- Seat adjusts from 22-32".
- 18" chrome footing.
- Manufacturer's limited lifetime warranty.
- GREENGUARD Certified.



ID No.	Color	Shpg. Wt.	Unit	Price
<b>C EXTENDED-HEIGHT LAB STOOL</b>				
Supports up to 250 lbs. Seat: 18" x 18". Overall height: 22" to 32". <sup>①</sup>				
4	SAF-3436BL Black Vinyl	18 lbs.	Each	<del>467.00</del>

## Height-Adjustable Lab Stool

Easy to clean vinyl upholstered stool is ideal for medical and educational settings.

- 18" five-star base and casters offer support and mobility.
- Manufacturer's limited lifetime warranty.
- Meets or exceeds ANSI/BIFMA Standards.

ID No.	Color	Shpg. Wt.	Unit	Price
<b>D HEIGHT ADJUSTABLE LAB STOOL</b>				
Supports up to 250 lbs. Overall height: 16" to 21". <sup>①</sup>				
5	SAF-3434BL Black	12 lbs.	Each	<del>470.00</del>

**SAFCO**

## Pneumatic Lab Stools

Easy to clean vinyl upholstered stool adjusts in height for a variety of uses.

- Generously cushioned 16" diameter seat for comfort.
- Durable base provides extra stability.
- 360° swivel helps to support movement throughout the day, which may help support better circulation and ease pressure points.
- Manufacturer's limited lifetime warranty.
- Meets or exceeds ANSI/BIFMA Standards.



ID No.	Color	Shpg. Wt.	Unit	Price
<b>B PNEUMATIC LAB STOOL WITHOUT BACK</b>				
Supports up to 250 lbs. Seat: 16" x 3½". Overall height: 17" to 22". <sup>①</sup>				
3	SAF-3431BL Black	17 lbs.	Each	<del>344.00</del>

For more information on additional chair features see page 80.

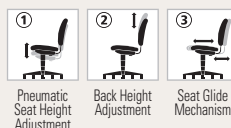





**SAFCO**

## Diesel Industrial Stools

Ideally suited for workbench and work table use in the industrial, institutional and educational industries.

- Thick, recycled leather padded seat provides extreme comfort.
- Nonmarring feet protect floor.
- Manufacturer's limited lifetime warranty.
- GREENGUARD Certified.

ID No.	Color	Shpg. Wt.	Unit	Price
--------	-------	-----------	------	-------

### A INDUSTRIAL STOOL WITH STATIONARY SEAT

Supports up to 250 lbs. Overall height: 23" to 30".

#### Adjustable Height

1	SAF-6666	Pewter	20 lbs.	Each	<del>128.00</del>
2	SAF-6666SL	Silver	16 lbs.	Each	<del>128.00</del>

### B INDUSTRIAL STOOL WITH BACK

Supports up to 250 lbs. Back: 12" x 7". Overall height: 36" to 41".

**Stool with Back**—Use at workbench or worktable.

3	SAF-6664	Pewter	23 lbs.	Each	<del>300.00</del>
4	SAF-6664SL	Silver	22 lbs.	Each	<del>300.00</del>

### C INDUSTRIAL STOOL

Leather padded seat. Supports up to 250 lbs. Overall height: 22" to 27".

**Backless Stool**—Use at workbench or worktable.

5	SAF-6665	Pewter	17 lbs.	Each	<del>207.00</del>
---	----------	--------	---------	------	-------------------

## Lab Stool

Pneumatic lift adjusts height with simple foot pedal plate.

- Five-star nylon base for stability.
- Easy-to-clean vinyl seat.
- Manufacturer's limited lifetime warranty.

ID No.	Color	Shpg. Wt.	Unit	Price
--------	-------	-----------	------	-------

### D LAB STOOL

Supports up to 250 lbs. Seat:  $\times 24\frac{1}{4}$ ". Overall height: 19 $\frac{1}{4}$ " to 24 $\frac{1}{2}$ ".

6	SAF-3437BL	Black	13 lbs.	Each	<del>224.00</del>
---	------------	-------	---------	------	-------------------

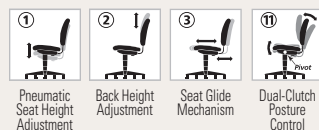

For more information on additional chair features see page 80.

## Task Master® Industrial Seating

For 24/7, intensive-use.

- Adjusts 8" up or down pneumatically while seated and an additional 10" manually with patented Wave Tube Extension.
- Oversized seat and back covered in black microcellular, self-skinning polyurethane foam.
- Large base ensures stability.
- Wide-angled footrest provides secure footing and ergonomically correct leg position.
- Manufacturer's limited lifetime warranty.
- Meets or exceeds ANSI/BIFMA Standards.

ID No.	Color	Shpg. Wt.	Unit	Price
--------	-------	-----------	------	-------

### E ECONOMY INDUSTRIAL CHAIR

Ideal for installations with multiple applications and height ranges. Supports up to 250 lbs. Seat: 16 $\frac{1}{4}$ " x 16 $\frac{1}{4}$ ". Back: 14 $\frac{1}{2}$ " x 9". Overall height: 17" to 35".

7	SAF-5117	Black	32 lbs.	Each	<del>603.00</del>
---	----------	-------	---------	------	-------------------

## Stools

Versatile mobile stool is perfect for technical applications at home or at work.

- Perfect companion to height-adjustable tables.
- Backless design for mobility.
- Adjustable seat height for application flexibility.
- Manufacturer's limited five-year warranty.
- Meets or exceeds ANSI/BIFMA Standards.

ID No.	Color	Shpg. Wt.	Unit	Price
--------	-------	-----------	------	-------

### F TECH STOOL

The molded polyurethane seat provides sculpted comfort and support. The chrome foot ring is height adjustable, providing additional adjustability. Durable and easy-to-clean seat. Supports up to 250 lbs. Seat: 17" x 14 $\frac{1}{4}$ ". Overall height: 25 $\frac{1}{2}$ " to 35".

8	MLN-6005AGB	Black	35 lbs.	Each	<del>367.00</del>
---	-------------	-------	---------	------	-------------------

# Seating Stools



C

## Steel Stools



A

Black



B

Silver



C

Black



Vy™  
Bistro  
Chair

Black  
(BL)



## Bar-Height Steel Stool

All steel construction.

- Powder coat finish.
- Easy-to-clean glossy finish.
- Includes footring.
- Nylon glides.
- Easy assembly.
- Stackable up to 3 high.
- Manufacturer's limited lifetime warranty.

ID No.	Color	Shpg. Wt.	Unit	Price
<b>A BAR-HEIGHT STEEL STOOL</b>				
Supports up to 250 lbs. Seat: 13" x 13". Overall height: 29".				
1	SAF-6606BL	Black	11 lbs.	Each <del>116.00</del>
2	SAF-6606SL	Silver	11 lbs.	Each <del>116.00</del>

### B COUNTER-HEIGHT STEEL STOOLS

Supports up to 250 lbs. Seat: 13" x 13". Overall height: 25".

3	SAF-6605BL	Black	10 lbs.	Each <del>105.00</del>
4	SAF-6605SL	Silver	10 lbs.	Each <del>105.00</del>

## Vy™ Sled Base Bistro Chair

Rated up to 350 lbs.

- Sled base bistro height leg frame.
- Steel powder coat frame with silver finish.
- Manufacturer's limited lifetime warranty.
- GREENGUARD Certified; Meets or exceeds ANSI/BIFMA Standards.

ID No.	Color	Shpg. Wt.	Qty.	Unit	Price
<b>C SLED BASE BISTRO CHAIR</b>					
Supports up to 350 lbs. Seat: 19½" x 18". Back: 19½" x 15¼". Overall height: 45".					
5	SAF-4295BL	Black	69 lbs.	1 Each	<del>284.00</del>





## Ravino Big & Tall Series

Designed to provide maximum support and comfort to the big and tall user.

- Plush pillow-top seat and back for comfort.
- Open-loop aluminum arms with padded armrests.
- Soft black leather upholstery.
- Chrome-plated five-star base with nylon casters for easy mobility.
- Manufacturer's limited five-year warranty.
- Meets or Exceeds ANSI/BIFMA Standards.

ID No.	Seat/Back Color	Base Color	Shpg. Wt.	Unit	Price
--------	-----------------	------------	-----------	------	-------

### A HIGH-BACK BIG AND TALL SWIVEL/TILT LEATHER CHAIR

Supports up to 450 lbs.

Seat: 22.88" x 21.75". Back: 22" x 32.75". Overall height: 42.88" to 46".

1	ALE-RV44LS10C	Black/Black	Chrome	73 lbs.	Each	415.00
---	---------------	-------------	--------	---------	------	--------

## Maxxis Big & Tall Series

Make a statement with this ultra comfortable and cushioned chair for the big and tall user.

- Luxurious leather upholstery and mattress-like coil springs.
- Unique gel cooling pad technology under the upholstery provides instant even cooling.
- Heavy-duty chrome base and mechanism are reinforced and help to evenly distribute weight.
- Ultra-padded armrest, headrest and bolsters.
- Waterfall seat edge helps to reduce pressure points at the back of the knee.
- Manufacturer's limited five-year warranty.
- Meets or Exceeds ANSI/BIFMA Standards.

ID No.	Seat/Back Color	Base Color	Shpg. Wt.	Unit	Price
--------	-----------------	------------	-----------	------	-------

### B HIGH-BACK LEATHER CHAIR

Supports up to 500 lbs.

Seat: 25 1/4" x 21 1/4". Back: 24" x 33". Overall height: 44 7/8" to 48 1/2".

2	ALE-MS4419	Black/Black	Chrome	79 lbs.	Each	425.00
---	------------	-------------	--------	---------	------	--------

### C EXECUTIVE LEATHER CHAIR

Supports up to 450 lbs.

Seat: 25 1/4" x 21 1/4". Back: 24 3/4" x 26". Overall height: 39 1/2" to 43 1/2".

3	ALE-MS4519	Black/Black	Chrome	69 lbs.	Each	750.00
---	------------	-------------	--------	---------	------	--------

### D LEATHER OFFICE CHAIR

Supports up to 350 lbs. Ideal for the shorter user.

Seat: 25 1/4" x 21 1/4". Back: 24 3/4" x 30 1/4". Overall height: 43 1/2" to 46 7/8".

4	ALE-MS4619	Black/Black	Chrome	66 lbs.	Each	570.00
---	------------	-------------	--------	---------	------	--------



### Great Service

We can help you with selection & solutions.

For more information on additional chair features see page 80.



Pneumatic Seat Height Adjustment  
 Tilt Tension/Tilt Lock



A

Ravino Series

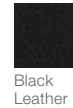

Black Leather



Black Leather



B

Black Leather



C

Black Leather



Maxxis Series



Black Leather



D

Black Leather





# Seating Big & Tall



A

Black

1-Forty-One



Black  
(T141)



B

Black

3-Forty-One



Black Leather  
(T341)



C

Black

Validate™



Black Leather  
(SB11)



D

Black

Wave™



Black  
(VM10)



E

Black

Crio™



Black  
(ES10)



## 1-Forty-One Big & Tall Mesh Task Chair

Offers luxurious comfort and support.

- Customizable features include an adjustable lumbar support for the lower back, height-adjustable arms and a 360-swivel seat that quickly moves up and down to fit a variety of users.
- Mesh back creates breathable support that stretches to reduce pressure points, while the cushioned fabric seat offers plush comfort all day long.
- Whether used in a workstation or a home office, this chair provides the upscale style, ergonomic support and low price that makes it an attractive option for anyone seeking a little extra structural support.
- Sadie™ Limited Three-Year Warranty.
- Meets or Exceeds ISTA Performance Standards.

ID No.	Seat/Back Color	Base Color	Shpg. Wt.	Unit	Price
--------	-----------------	------------	-----------	------	-------

### A BIG & TALL MESH TASK CHAIR

Supports up to 350 lbs.

Seat: 22" × 19.8". Back: 22" × 42.91". Overall height: 39.37" to 42.91".

1	BSX-VST141	Black/Black	Black	49 lbs.	Each	<del>422.00</del>
---	------------	-------------	-------	---------	------	-------------------

## 3-Forty-One Big & Tall Chair

Classic leather meets modern design.

- Offers simple and intuitive controls.
- Fixed, padded arms provide upper body support.
- Segmented padded back and seat with ultra plush cushioning.
- Sadie™ Limited Three-Year Warranty.
- Meets or Exceeds ISTA Performance Standards.

ID No.	Seat/Back Color	Base Color	Shpg. Wt.	Unit	Price
--------	-----------------	------------	-----------	------	-------

### B HIGH-BACK TASK CHAIR

Supports up to 400 lbs.

Seat: 23" × 21". Back: 23" × 27". Overall height: 44.88".

2	BSX-VST341	Black/Black	Aluminum	57 lbs.	Each	<del>499.00</del>
---	------------	-------------	----------	---------	------	-------------------

For more information on additional chair features see page 80.



## Validate™ Big & Tall Leather Chair

Designed for the big and tall individual.

- Thick cushions provide support and comfort.
- Heavy-duty construction provides extreme durability.
- Stylish leather executive chair with integrated headrest.
- Padded loop arms and easy-maintenance leather upholstery.
- Backed by the HON Limited Five-Year Warranty.

ID No.	Seat/Back Color	Base Color	Shpg. Wt.	Unit	Price
--------	-----------------	------------	-----------	------	-------

### C BIG & TALL LEATHER CHAIR

Supports up to 450 lbs.

Seat: 22.25" × 20". Back: 21" × 28.5". Overall height: 45.25" to 48".

#### SofThread™ Leather

3	BSX-VL685SB11	Black/Black	Black	67 lbs.	Each	<del>977.00</del>
---	---------------	-------------	-------	---------	------	-------------------

## Wave™ Mesh Big & Tall Chair

Provides comfort and long-lasting performance for people weighing up to 450 lbs.

- Adjustable lumbar support helps reduce back fatigue.
- Five-star base with casters for easy mobility.
- Height and width adjustable arms and tilt tension/tilt lock control for comfortable recline.
- Backed by the HON Limited Five-Year Warranty.

ID No.	Seat/Back Color	Base Color	Shpg. Wt.	Unit	Price
--------	-----------------	------------	-----------	------	-------

### D MESH BIG & TALL CHAIR

Supports up to 450 lbs.

Seat: 21.63" × 18.75". Back: 22.88" × 27.5". Overall height: 39.88" to 42.88".

4	BSX-VL705VM10	Black/Black	Black	59 lbs.	Each	<del>784.00</del>
---	---------------	-------------	-------	---------	------	-------------------

## Crio™ Big & Tall Mid-Back Task Chair

Comfort, support and functionality specially engineered for users up to 450 pounds.

- Built-in lumbar support.
- Breathable mesh back.
- Height/width-adjustable arms.
- Backed by the HON Limited Five-Year Warranty.
- Meets or Exceeds ISTA Performance Standards.

ID No.	Seat/Back Color	Base Color	Shpg. Wt.	Unit	Price
--------	-----------------	------------	-----------	------	-------

### E BIG & TALL MID-BACK TASK CHAIR

Supports up to 450 lbs.

Seat: 22" × 22". Back: 22" × 28". Overall height: 38" to 45".

5	BSX-VL585ES10T	Black/Black	Black	50 lbs.	Each	<del>612.00</del>
---	----------------	-------------	-------	---------	------	-------------------





**A**

Black Leather



Serenity™  
Big & Tall Seating

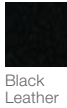

Black Leather



**B**

Black Vinyl



Optimus™  
Big & Tall Chair



Black Vinyl



Black Fabric



**C**

Black Fabric



Uber™  
Series

Black Fabric

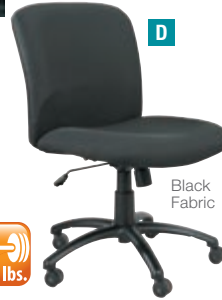

**D**

Black Fabric

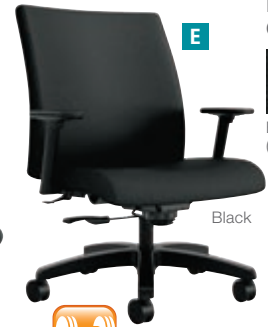

**E**

Black



Ignition®  
Chair

Black (CU10)

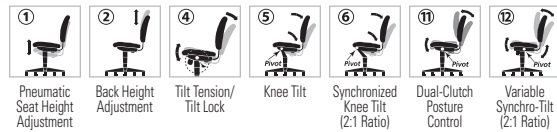

For more information on additional chair features see page 80.



## Serenity™ Big & Tall Leather Seating

The perfect solution for every unique work environment.

- Specially designed for the big and tall person, chair is rated up to 500 lbs.
- Leather upholstery for comfort.
- Supportive padded loop arms.
- Oversized five-star base with casters for stability and mobility.
- Features swivel seat with pneumatic height adjustment, tilt lock and tilt tension that may help support correct posture and help ease pressure points.
- Manufacturer's limited lifetime warranty.
- Meets or exceeds ANSI/BIFMA Standards.

ID No. Color Shpg. Wt. Unit Price

### A HIGH-BACK CHAIR

Supports up to 500 lbs.

Seat: 21½" × 22". Back: 22" × 26". Overall height: 45½" to 48½".

1 SAF-3500BL Black 62 lbs. Each ~~650.00~~

## Optimus™ High Back Big & Tall Chair

Designed for every shape and size, this chair features a 400 lb. weight capacity and 24/7 use.

- Features back height adjustment, back tilt, tilt lock and tilt tension to allow users to adjust to their comfort level and may help to support better posture and help ease pressure points.
- Smooth-rolling casters for easy mobility.
- Reinforced mechanism to provide proper support to the body.
- Manufacturer's limited lifetime warranty.
- GREENGUARD Certified.

ID No. Color Shpg. Wt. Unit Price

### B HIGH BACK BIG & TALL CHAIR

Supports up to 400 lbs.

Seat: 23" × 22". Back: 22" × 25". Overall height: 42½" to 45½".

#### Vinyl

2 SAF-3592BL Black 61 lbs. Each ~~500.00~~

#### Fabric

3 SAF-3590BL Black 62 lbs. Each ~~554.00~~

### OPTIONAL HEIGHT- AND WIDTH-ADJUSTABLE T-PAD ARMS

Optional height- and width-adjustable armrests provide custom comfort and help reduce strain on neck and shoulders. Attach easily to Optimus™ Big & Tall chairs.

4 SAF-3591BL Black Pair ~~494.00~~



## Uber™ Big & Tall Chair Series

Chair fits a variety of individuals and environments.

- Extra-wide and deep seat.
- Cushioned foam is rated for 24/7 use and chair is rated up to 500 lbs.
- Manufacturer's limited lifetime warranty.
- GREENGUARD Certified; Meets or exceeds ANSI/BIFMA Standards.

ID No. Color Shpg. Wt. Unit Price

### C HIGH-BACK CHAIR

Supports up to 500 lbs.

Seat: 22¼" × 20¾". Back: 23" × 23". Overall height: 40¾" to 44¾".

#### Fabric

5 SAF-3490BL Black 49¼ lbs. Each ~~655.00~~

### D MID-BACK CHAIR

Supports up to 500 lbs.

Seat: 22¼" × 20¾". Back: 23" × 19¾". Overall height: 36½" to 40½".

#### Fabric

6 SAF-3491BL Black 54 lbs. Each ~~602.00~~

### OPTIONAL HEIGHT-ADJUSTABLE T-PAD ARMS

Adjust to accommodate comfort to each user. Minimize neck and shoulder strain. Easy to install.

7 SAF-3496BL Black Pair ~~429.00~~



## Ignition® Series Seating

Ignition® addresses the needs of the total office with executive, work, task and guest seating solutions.

- Breathable mesh back offers comfort and support.
- Easily mobile on four dual-wheel casters.
- Backed by the HON Full Lifetime Warranty.
- Level 2 Certified; Meets or exceeds ANSI/BIFMA Standards and ISTA Performance Standards; SCS Indoor Advantage Gold Certified.

ID No. Color Shpg. Wt. Unit Price

### E BIG & TALL MID-BACK TASK CHAIR

Supports up to 450 lbs.

Seat: 24" × 20". Back: 24" × 23". Overall height: 40" to 43".

8 HON-IW801CU10 Black 63 lbs. Each ~~4,340.00~~



# Seating Big & Tall



**ALERA**

Mota Series  
Black

Merix450 Series  
Black Mesh

**ANSI MEETS BIFMA**

## Alera® Mota Series Big & Tall Series

**Generously padded contoured seating ideal for the big and tall user.**

- Reinforced seating structure and steel base for maximum reliable support.
- Enhanced padding and fabrics for extra support all-day long.
- Height-adjustable soft-padded T-arms for optimal arm positioning.
- Waterfall seat edge reduces pressure points at the back of the knees.
- Manufacturer's limited five-year warranty.
- Contains 5% post-consumer recycled content, 30% total recycled content.
- Meets or Exceeds ANSI/BIFMA Standards.

ID No.	Seat/Back Color	Base Color	Shpg. Wt.	Unit	Price
<b>A BIG AND TALL CHAIR</b>					
Supports up to 450 lbs. Seat: 23.25" x 22". Back: 23.63" x 24.5". Overall height: 41.75" to 45.25".					
1	ALE-MT4510	Black/Black	Black	63 lbs.	Each <del>645.00</del>
<b>B BIG AND TALL STOOL</b>					
Welded integrated footring for leg support. Supports up to 450 lbs. Seat: 23.63" x 21". Back: 22" x 21.25". Overall height: 45.63" to 49.25".					
2	ALE-MT4610	Black/Black	Black	65 lbs.	Each <del>765.00</del>

## Alera® Merix450 Series Mesh Big and Tall Chair

**Aesthetically stylish for superior sitting experience for users up to 450 lbs.**

- Engineered and designed to fit the big and tall user.
- Breathable fabric mesh back with super cushioned mesh fabric seat.
- Integrated lumbar support encourages ideal back posture.
- Manufacturer's limited five-year warranty.
- Meets or Exceeds ANSI/BIFMA Standards.

ID No.	Seat/Back Color	Base Color	Shpg. Wt.	Unit	Price
<b>C MESH BIG &amp; TALL MID-BACK SWIVEL/TILT CHAIR</b>					
Supports up to 450 lbs. Seat: 23.25" x 20.88". Back: 19.63" x 26.75". Overall height: 39.13" to 42.75".					
3	ALE-MX4517	Black/Black	Black	53 lbs.	Each <del>600.00</del>

For more information on additional chair features see page 80.



XL Series  
Black

Oversize Stack Chairs  
Black Vinyl

**ANSI MEETS BIFMA**

## Alera Plus® XL Series Big & Tall Chairs

**A fusion of remarkable style and exceptional ergonomics for larger individuals up to 500 lbs.**

- Smartly engineered wrap-frame construction effectively redistributes user weight for maximum strength and durability.
- Push sculptured seat and back are ideal for the plus-size user.
- Contoured stitched upholstery and custom-designed back strap for superior aesthetics.
- Reinforced high-strength base with casters/glides.
- Manufacturer's limited five-year warranty. Meets or Exceeds ANSI/BIFMA Standards.

ID No.	Seat/Back Color	Base Color	Shpg. Wt.	Unit	Price
<b>D BIG &amp; TALL HIGH-BACK TASK CHAIR</b>					
Supports up to 500 lbs. Seat: 22" x 20.75". Back: 22" x 22.5". Overall height: 43.5" to 47.5".					
4	ALE-CP110	Black/Black	Black	55 lbs.	Each <del>545.00</del>
<b>E BIG &amp; TALL MID-BACK TASK CHAIR</b>					
Supports up to 500 lbs. Seat: 22" x 20.75". Back: 22" x 19.5". Overall height: 40.5" to 44.5".					
5	ALE-CP210	Black/Black	Black	53 lbs.	Each <del>510.00</del>

## Oversize Stack Chairs

**Heavy-duty chair with built-in lumbar support is designed to accommodate larger guests.**

- Extra-wide seat with waterfall edge has a 3 1/2" foam cushion for all-day comfort. Durable 18 gauge, 1" steel frame with front and back stretcher bars for added strength.
- Stacks up to 5 high for space-efficient storage.
- Great for healthcare facilities, dining halls, guest seating or any multi-use application where comfort and durability are needed.
- Manufacturer's limited five-year warranty.
- Contains 30% post-consumer recycled content, 30% total recycled content.
- Meets or Exceeds ANSI/BIFMA Standards.

ID No.	Seat/Back Color	Base Color	Shpg. Wt.	Qty. Unit	Price
<b>F OVERSIZE STACK CHAIR WITH FIXED PADDED ARMS</b>					
Supports up to 500 lbs. Seat: 20.5" x 15.5". Back: 20" x 19.75". Overall height: 35.5".					
6	ALE-BT6516	Black/Black	Black	50 lbs.	2 Carton <del>645.00</del>
<b>G OVERSIZE STACK CHAIR WITHOUT ARMS</b>					
Supports up to 500 lbs. Seat: 20.5" x 15.5". Back: 20" x 19.75". Overall height: 35.5".					
7	ALE-BT6616	Black/Black	Black	46 lbs.	2 Carton <del>595.00</del>



**HON.**

## Adjustable Task/Lab Stool

Anti-microbial upholstery makes this stool ideal for use by healthcare providers in exam rooms.

- Height-adjustable for each user's comfort.
- Anti-microbial upholstery wipes clean with ease.
- Backed by the HON Full Lifetime Warranty.
- Meets or Exceeds ANSI/BIFMA Standards and ISTA Performance Standards.



ID No.	Shpg. Wt.	Unit	Price
--------	-----------	------	-------

### A ADJUSTABLE TASK/LAB STOOL

Supports up to 250 lbs. Seat: 16" dia. Back: 15.5" x 10". Overall height: 31.5" to 38".

**With Back**—Seat: 16" dia. Overall Height: 31½" to 38".

1	HON-MTS11EA11	27 lbs.	Each	<del>490.00</del>
2	HON-MTS01EA11	20 lbs.	Each	<del>367.00</del>

**ALERA.**

## Height-Adjustable Utility Stool

Easy ring-activated height adjustment anywhere you reach.

- Easy-to-clean antimicrobial upholstery.
- Five-star graphite base with integrated support ring.
- Manufacturer's limited five-year warranty.
- Contains 5% post-consumer recycled content, 30% total recycled content.
- Meets or Exceeds ANSI/BIFMA Standards.



ID No.	Color	Shpg. Wt.	Unit	Price
--------	-------	-----------	------	-------

### B HEIGHT-ADJUSTABLE UTILITY STOOL

Supports up to 275 lbs. Seat: 18.25" dia. Back: Overall height: 22" to 29.5".

3	ALE-US4616	Graphite	23 lbs.	Each	<del>245.00</del>
---	------------	----------	---------	------	-------------------

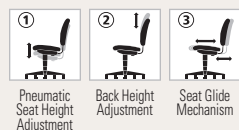

For more information on additional chair features see page 80.

## Height Adjustable Lab Stool

This classic "lab" stool is easy to keep clean and scoot around a busy workplace.

- Thick padded molded-foam seat retains its comfort and shape even with prolonged use.
- Chrome five star base.
- Easy to store under nearly any work surface.
- Manufacturer's limited five-year warranty.
- Meets or Exceeds ANSI/BIFMA Standards.

ID No.	Color	Shpg. Wt.	Unit	Price
--------	-------	-----------	------	-------

### C LAB STOOL

Supports up to 275 lbs. Seat: 15.75" dia. Back: Overall height: 19.25" to 24.38".

4	ALE-US4716	Chrome	16 lbs.	Each	<del>499.00</del>
---	------------	--------	---------	------	-------------------

## HL Series Stools

Anti-microbial upholstered seat and chrome plated steel frame delivers a wipe friendly stool.

- Contemporary styling and advanced ergonomics for healthcare, laboratory, educational or task environments.
- Easy activation handle for seat height adjustment.
- Dual wheel hooded casters for mobility.
- Manufacturer's limited five-year warranty.
- Meets or Exceeds ANSI/BIFMA Standards.

ID No.	Shpg. Wt.	Unit	Price
--------	-----------	------	-------

### D HEIGHT-ADJUSTABLE STOOL

Supports up to 300 lbs. Seat: 16" dia. Back: Overall height: 18" to 24".

5	ALE-CS614		20 lbs.	Each	<del>279.00</del>
---	-----------	--	---------	------	-------------------

## IL Series

Innovative design elements embodied in steel construction.

- Perfect for workbench, service desk and work table use in industrial, commercial and educational environments.
- Tools-free seat height adjustment in a 10" range.
- Foldable for fast set-up and compact storage.
- Clever sit-to-stand ergonomics to enhance productivity.
- Wipe-friendly vinyl upholstered seat and back facilitates easy maintenance.
- Non-marring rubber sleeved legs ensure stability.
- Manufacturer's limited five-year warranty.
- Contains 30% post-consumer recycled content, 30% total recycled content.
- Meets or Exceeds ANSI/BIFMA Standards.

ID No.	Color	Shpg. Wt.	Unit	Price
--------	-------	-----------	------	-------

### E HEIGHT-ADJUSTABLE FOLDING STOOL

Supports up to 300 lbs. Seat: 16" x 10.5". Back: 14" x 9". Overall height: 24.5" to 34.5".

6	ALE-CS612	Black	20 lbs.	Each	<del>209.00</del>
---	-----------	-------	---------	------	-------------------

# Seating Stools



Sorrento Series  
Black



## Industrial Stools

Ideal in the shop, garage, science lab, art studio, factory floor or anywhere where durability matters most.

- Sturdy steel frame and seat pan with scratch-resistant powder-coat finish.
- Warp-, crack- and chip-proof Masonite seat board.
- Stackable to save space when not in use.
- Manufacturer's limited five-year warranty.
- Meets or Exceeds ANSI/BIFMA Standards.

ID No.	Color	Shpg. Wt.	Unit	Price
--------	-------	-----------	------	-------

### A METAL SHOP STOOL

Features a foot ring and non-marring floor glides. Supports up to 300 lbs. Seat: 14" dia. Overall height: 18" to 30".

#### 18" Seat Height

1	ALE-IS6618G	Brown/Gray	10 lbs.	Each	<del>50.00</del>
---	-------------	------------	---------	------	------------------

#### 24" Seat Height

2	ALE-IS6624G	Brown/Gray	11 lbs.	Each	<del>55.00</del>
---	-------------	------------	---------	------	------------------

#### 30" Seat Height

3	ALE-IS6630G	Brown/Gray	14 lbs.	Each	<del>60.00</del>
---	-------------	------------	---------	------	------------------

## IV Series Guest Stool

Versatile line of stacking chairs and stools.

- Perfect for common areas, waiting rooms and guest seating.
- Contoured back provides enhanced comfort and back support.
- Two chairs per carton.
- Manufacturer's limited five-year warranty.
- Contains 5% post-consumer recycled content, 30% total recycled content.
- Meets or Exceeds ANSI/BIFMA Standards.

ID No.	Color	Shpg. Wt.	Unit	Price
--------	-------	-----------	------	-------

### B GUEST STOOL

Supports up to 275 lbs. Seat: 19.63" x 19.25". Back: 18.75" x 13.38". Overall height: 44.5".

4	ALE-IV4614A	Black	55 lbs.	Carton	<del>619.00</del>
---	-------------	-------	---------	--------	-------------------

## Sorrento Series Stool

Cushioned seat and base for comfort.

- Black steel base with straight legs.
- Faux leather upholstery.
- Perfect for hospitality areas including waiting rooms, counters, or conference rooms.
- Steel construction for strength and durability.
- Two chairs per carton.
- Manufacturer's limited five-year warranty.
- Contains 5% post-consumer recycled content, 30% total recycled content.
- Meets or Exceeds ANSI/BIFMA Standards.

ID No.	Color	Shpg. Wt.	Qty.	Unit	Price
--------	-------	-----------	------	------	-------

### C STOOL

Supports up to 300 lbs. Seat: 19.75" x 18.25". Back: 17.75" x 11.5". Overall height: 43.25".

#### Without Arms

5	ALE-ST6616	Black	52 lbs.	2	Carton	<del>435.00</del>
---	------------	-------	---------	---	--------	-------------------

#### With Arms

6	ALE-ST6616A	Black	56 lbs.	2	Carton	<del>470.00</del>
---	-------------	-------	---------	---	--------	-------------------

## Perch Stool

Comfortable, stylish and adjustable.

- Ideal for general office, task, interactive and collaborative environments.
- Push comfortable seat with tilt feature allows user to perch in a dynamic work position.
- Seat height range suitable for adjustable workbench, desk and counter applications.
- Ready-to-reach handles for hassle-free adjustment.
- Built-in handle for portability.
- Round steel base provides reliable and firm support.
- Manufacturer's limited five-year warranty.
- Meets or Exceeds ANSI/BIFMA Standards.

ID No.	Color	Shpg. Wt.	Unit	Price
--------	-------	-----------	------	-------

### D PERCH SIT STOOL

Supports up to 250 lbs. Seat: 14" x 14". Overall height: 25.25" to 35.5".

7	ALE-SQ600	Black	22 lbs.	Each	<del>309.00</del>
---	-----------	-------	---------	------	-------------------

## SS Series

Designed to deliver the comfort of sitting even when standing.

- Perfect for front office, reception, back office, workbench, service desk, production floor, tradeshow and many commercial environments.
- Ergonomic seat is height adjustable for desk or counter heights and pivots from flat to angled for both sitting and leaning.
- Solid, wide steel support is tip-proof, even when leaning far forward.
- Tear/poke resistant and wipe-friendly seat facilitates easy maintenance.
- Non-marring rubber padded base assures stability.
- Manufacturer's limited five-year warranty.
- Meets or Exceeds ANSI/BIFMA Standards.

ID No.	Color	Shpg. Wt.	Unit	Price
--------	-------	-----------	------	-------

### E SIT/STAND ADJUSTABLE STOOL

Supports up to 300 lbs. Seat: 14" x 8.5". Overall height: 35.5".

8	ALE-SS600	Black	26 lbs.	Each	<del>372.66</del>
---	-----------	-------	---------	------	-------------------



Pneumatic Seat Height Adjustment



Posture Lock



Dual-Clutch Posture Control

For more information on additional chair features see page 80.





## SAFCO ACTIVE

### A BALANCE BOARD

Balance board designed to encourage a more active workday. Manufacturer's limited lifetime warranty.

ID No.	W x D x H	Color	Unit	Price
1 SAF-2128BL	32¼" x 12¼" x 3"	Black	Each	<del>464.00</del>

### B STABILIZING FOOTREST BY FOCAL UPRIGHT™

May help to take pressure off of your foot bones. It also allows you to keep moving by encouraging you to vary your posture throughout the workday. Can be paired with standing desks or tables, and traditional seated workstations. Can also be paired with other Safco Active Seating products. Features a non-slip design that keeps the footrest in place on hard and soft surfaces. Lightweight for easy portability; features non-marring Butyl rubber to keep from slipping. Made with a sturdy, extruded aluminum bar. Designed by Martin Keen. Manufacturer's limited lifetime warranty.

ID No.	W x D x H	Color	Unit	Price
2 SAF-FFR1000	14" x 26" x 3½"	Aluminum/Black	Each	<del>97.00</del>

## SAFCO

### C HEIGHT-ADJUSTABLE FOOTREST

Provides an ergonomic solution for your feet and back while sitting or standing. Constructed of steel and aluminum with a nylon platform for durability, and raised bumps on the platform for added foot grip. Clean, industrial appearance is great for any desk or table, as well as backroom and warehouse use. The footrest can also be paired with a standing workstation for added ergonomic support. Infinitely adjustable with cam-lock to set at desired height for user comfort, from 3½ inches to 16 inches. Manufacturer's limited lifetime warranty.

ID No.	W x D x H	Color	Unit	Price
3 SAF-2129BL	20½" x 14½" x 3½" to 21½"	Black	Each	<del>467.00</del>

## VICTOR

### D STEPIE MOTION BOARD

Perfect complement to a standing desk workstation, such as the Victor® High Rise™ Collection. This stylish yet unobtrusive motion board features a simple design that helps improve overall body wellness while you work. Designed with comfort in mind, the board gently rocks back and forth while strengthening and stabilizing muscles in the core, lower back, hips, legs and ankles. Other health benefits include improved posture, increased circulation, and improved joint mobility. Manufacturer's three-year warranty.

ID No.	W x D x H	Color	Unit	Price
4 VCT-ST570	22½" x 14½" x 2½"	Two-Tone Gray	Each	<del>429.00</del>

## ALERA.

### E RELAXING ADJUSTABLE FOOTREST

Provides precise ergonomic foot support for any user. Designed with roller surface bumps to help massage tired feet and keep your foot from slipping. Three tilt positions from 20 to 70 degrees and three height-adjustable positions. Non-slip, non-scratching floor pads keep your footrest in place on the floor. Manufacturer's limited five-year warranty.

ID No.	W x D x H	Color	Unit	Price
5 ALE-FS212	13¾" x 17¾" x 4½" to 6¾"	Black	Each	<del>99.00</del>

### F ERGO TILT FOOTREST

Tilting footrest for proper ergonomic alignment. Versatile foot-adjustable tilt mechanism rolls back and forth for ideal angle from 0 to 20 degrees. Ribbed surface prevents feet from slipping. Non-slip, non-scratching floor pads keep your footrest in place on the floor. Manufacturer's limited five-year warranty.

ID No.	W x D x H	Color	Unit	Price
6 ALE-FS312	13¾" x 17¾" x 3¾" to 5¾"	Black	Each	<del>99.00</del>

Prices subject to change without notice.  
Visit our website for the latest pricing and product information.

# Seating Nesting

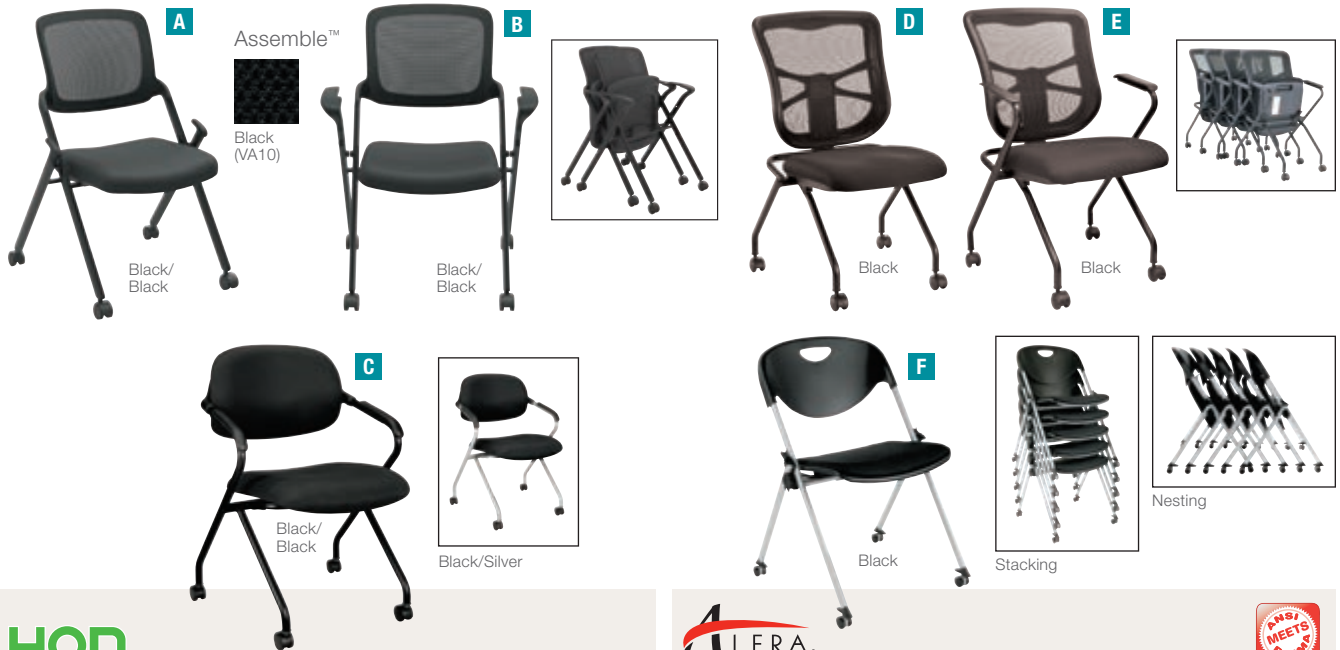

**HON.**

## Assemble™ Stacking/ Nesting Chairs

Perfect for multipurpose areas, training spaces and anywhere reconfiguration and space are priorities.

- Contemporary folding/nesting design with a flip-up seat.
- Breathable mesh back conforms to user's upper body.
- Generous foam seat cushion provides plush comfort and reduces pressure points.
- Integrated casters are designed to nest with frame to maximize space.
- Warranted for users up to 250 lbs.
- Ships two chairs per carton.
- Backed by the HON Limited Five-Year Warranty.
- Meets or Exceeds ISTA Performance Standards.

ID No.	Seat/Back Color	Base Color	Shpg. Wt.	Qty.	Unit	Price
<b>A ARMLESS STACKING/NESTING CHAIR</b>						
Supports up to 250 lbs. Seat: 18" x 19". Back: 17" x 18". Overall height: to 35".						
1	BSX-VL304BLK	Black/Black	Black	44 lbs.	2 Carton	<del>539.00</del>
2	BSX-VL304SLVR	Black/Black	Silver	44 lbs.	2 Carton	<del>539.00</del>
<b>B STACKING/NESTING CHAIR WITH ARMS</b>						
Supports up to 250 lbs. Seat: 18" x 19". Back: 17" x 18". Overall height: to 35".						
3	BSX-VL314BLK	Black/Black	Black	44 lbs.	2 Carton	<del>557.00</del>
4	BSX-VL314SLVR	Black/Black	Silver	44 lbs.	2 Carton	<del>557.00</del>

## VL300 Stacking/ Nesting Chairs

Up for any job, this chair works comfortably from the breakroom to the conference room.

- Contemporary design with an upholstered flip-up seat.
- Folds for space-efficient nested storage.
- Easy-rolling casters for mobility.
- Two chairs per carton.
- Backed by the HON Limited Five-Year Warranty.

ID No.	Seat/Back Color	Base Color	Shpg. Wt.	Qty.	Unit	Price
<b>C VL303 NESTING ARM CHAIR</b>						
Padded arm supports for added comfort. Folds to 8". Supports up to 250 lbs. Seat: 19.88" x 19.63". Back: 19.25" x 15.38". Overall height: to 33.5".						
5	BSX-VL303MM10T	Black/Black	Black	27 lbs.	1 Each	<del>292.00</del>
6	BSX-VL303MM10X	Black/Black	Platinum	29 lbs.	1 Each	<del>292.00</del>

**ALERA.**

## Alera® Elusion® Series Nesting Chairs

Ideal for training or conference rooms, or collaborative environments.

- Flip-up nesting seat design for easy high-density storage.
- Molded foam seat for resiliency and all day comfort.
- Cool breathable mesh back upholstery.
- Four-leg metal base with casters for durability and mobility.
- Manufacturer's limited five-year warranty.
- Contains 2% post-consumer recycled content, 5% total recycled content.
- Meets or Exceeds ANSI/BIFMA Standards.

ID No.	Seat/Back Color	Base Color	Shpg. Wt.	Qty.	Unit	Price
<b>D MESH NESTING CHAIRS</b>						
Supports up to 275 lbs. Seat: 19.25" x 18.88". Back: 20" x 19.75". Overall height: to 37.38".						
7	ALE-EL4915	Black/Black	Black	58 lbs.	2 Carton	<del>519.00</del>
<b>E WITH PADDED ARMS</b>						
8	ALE-EL4914	Black/Black	Black	68 lbs.	2 Carton	<del>549.00</del>

## Alera® SL Series

Appealing aesthetics and versatile design — ideal for everything from conference rooms to breakrooms.

- Innovative chair design can either nest or stack for storage when not in use.
- Generously sized seat with padded cushion and ergonomic back encourages proper posture.
- Strong powder coated steel frame with casters.
- Gangs, nests or stacks up to 12 high (two per carton).
- Fully-assembled.
- Manufacturer's limited five-year warranty.
- Contains 20% post-consumer recycled content, 20% total recycled content.
- Meets or Exceeds ANSI/BIFMA Standards.

ID No.	Seat/Back Color	Base Color	Shpg. Wt.	Qty.	Unit	Price
<b>F NESTING STACK CHAIR WITHOUT ARMS</b>						
Gang, nest or stack chairs together for use in reception or waiting areas. Supports up to 250 lbs. Seat: 17.88" x 16.5". Back: 20.5" x 11.63". Overall height: to 33.5".						
9	ALE-SL651	Black/Black	Gray	35 lbs.	2 Carton	<del>386.00</del>

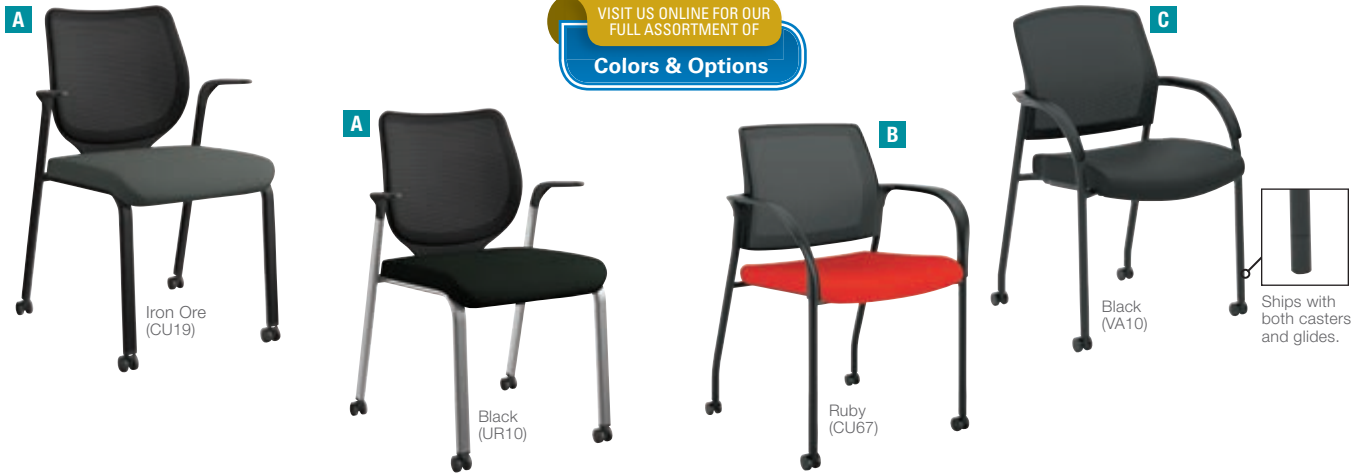

VISIT US ONLINE FOR OUR FULL ASSORTMENT OF  
**Colors & Options**

**Nucleus® Series**  
In Stock

**Special Order Upholstery**



Black Vinyl (UR10) Iron Ore (CU19) Navy (CU98) Ruby (CU67)

Requires additional lead time and cannot be returned.

**Ignition® Seating**  
In Stock

**Special Order Upholstery**

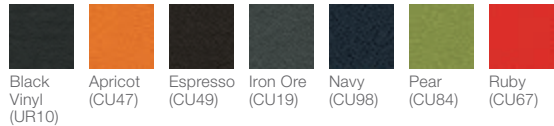

Black Vinyl (UR10) Apricot (CU47) Espresso (CU49) Iron Ore (CU19) Navy (CU98) Pear (CU84) Ruby (CU67)

Requires additional lead time and cannot be returned.

**Lota® Series**



Black (VA10)

## HON Nucleus® Series Seating



### Comfort from the inside out.

- Slender, contemporary look coordinates well with all office environments.
- Unique materials and innovative construction deliver surprising comfort without bulky padding.
- Multidirectional 4-way stretch mesh back puts lumbar support right where you need it.
- Stack up to four high for space-saving storage.
- Backed by the HON Full Lifetime Warranty.
- Contains 60% post-consumer recycled content, 62% total recycled content.
- Level 2 Certified; Meets or Exceeds ANSI/BIFMA Standards and ISTA Performance Standards; SCS Indoor Advantage Gold Certified.

ID No.	Seat/Back Color	Base Color	Shpg. Wt.	Qty.	Unit	Price
--------	-----------------	------------	-----------	------	------	-------

#### A MESH MULTIPURPOSE STACKING CHAIR

Easily mobile on four swivel casters. Stack up to four high for space-saving storage. Supports up to 300 lbs. Seat: 19" x 19". Back: 18" x 19". Overall height: 37.13".

##### Fabric Guest Black Frame

1	HON-N606HCU10	Black/ Black	Black	31 lbs.	1	Each <del>555.00</del>
2	HON-N606H_*	(Special Order)/ Black	Black	31 lbs.	1	Each <del>536.00</del>

##### Fabric Guest Platinum Frame

3	HON-N606HCU10T1	Black/ Black	Platinum	31 lbs.	1	Each <del>555.00</del>
---	-----------------	--------------	----------	---------	---	------------------------

##### Vinyl Guest Black Frame

4	HON-N606HUR10	Black/ Black	Black	31 lbs.	1	Each <del>536.00</del>
---	---------------	--------------	-------	---------	---	------------------------

##### Vinyl Guest Platinum Frame

5	HON-N606HUR10T1_*	Black/ Black	Platinum	31 lbs.	1	Each <del>536.00</del>
---	-------------------	--------------	----------	---------	---	------------------------

## Ignition® Seating



Ignition addresses the needs of the total office with executive, work, task and guest seating solutions.

- Contoured seat and back reduce pressure points.
- Height- and width-adjustable arms provide a custom fit.
- Backed by the HON Full Lifetime Warranty.
- Contains 14% post-consumer recycled content, 16% total recycled content.
- Level 2 Certified; Meets or Exceeds ANSI/BIFMA Standards and ISTA Performance Standards; SCS Indoor Advantage Gold Certified.

ID No.	Seat/Back Color	Base Color	Shpg. Wt.	Unit	Price
--------	-----------------	------------	-----------	------	-------

#### B MESH BACK MOBILE STACKING CHAIR

Multipurpose chair stocks up to four high for space-efficient storage. Breathable mesh back offers comfort and support. Easily mobile on four dual-wheel casters. Supports up to 300 lbs. Seat: 18" x 18". Back: 18" x 18". Overall height: 34".

##### Fabric

6	HON-IS107HIMCU10	Black/ Black	Black	33 lbs.	Each <del>462.00</del>
7	HON-IS107HIM_*	(Special Order)/ Black	Black	33 lbs.	Each <del>446.00</del>
8	HON-IS107IMCU10P*	Black/ Black	Platinum	28 lbs.	Each <del>469.00</del>

##### Vinyl

9	HON-IS107HIMUR10*	Black/ Black	Black	33 lbs.	Each <del>434.00</del>
10	HON-IS107IMUR10P*	Black/ Black	Platinum	28 lbs.	Each <del>459.00</del>

## Lota® Series



Style and substance, perfectly meshed.

- Mesh back adds a level of sophistication and comfort.
- Supports 250 lbs.
- Backed by the HON Full Lifetime Warranty.
- Meets or Exceeds ANSI/BIFMA Standards and ISTA Performance Standards.

ID No.	Seat/Back Color	Base Color	Shpg. Wt.	Unit	Price
--------	-----------------	------------	-----------	------	-------

#### C MESH MULTIPURPOSE STACKING CHAIR

Casters and glides are packaged with the chair, enabling conversion from mobile to stationary use. Stack up to four high. Supports up to 250 lbs. Seat: 18.88" x 17.75". Back: 17.88" x 17.75". Overall height: 34.5".

11	HON-2285VA10	Black/ Black	Black	20 lbs.	Each <del>392.00</del>
----	--------------	--------------	-------	---------	------------------------

**\*IMPORTANT:** When ordering special order items, add the finish code to the model number. Codes vary in length and placement. Example: ABC-12345**AB**

Prices subject to change without notice.  
Visit our website for the latest pricing and product information.

# Seating Stacking



## Alera® IV Series

Versatile line of stacking chairs and stools.

- Perfect for common areas, waiting rooms and guest seating.
- Contoured back provides enhanced comfort and back support.
- Two chairs per carton.
- Manufacturer's limited five-year warranty.
- Contains 5% post-consumer recycled content, 30% total recycled content.
- Meets or Exceeds ANSI/BIFMA Standards. ♻️ ♻️ ♻️

ID No.	Seat/Back Color	Base Color	Shpg. Wt.	Unit	Price
--------	-----------------	------------	-----------	------	-------

### A GUEST CHAIR

Casters and glides included. Supports up to 275 lbs.  
Seat: 19.25" × 19.25". Back: 14" × 18.75". Overall height: 33".

**Fabric Seat & Back**—Fabric Seat & Back

1	ALE-IV4317A	Black/Black	Black	47 lbs.	Carton	<del>469.00</del>
---	-------------	-------------	-------	---------	--------	-------------------

**Leather Back & Seat**—Leather Back & Seat

2	ALE-IV4319A	Black/Black	Black	47 lbs.	Carton	<del>485.00</del>
---	-------------	-------------	-------	---------	--------	-------------------

**Mesh Back, Fabric Seat**—Mesh Back, Fabric Seat

3	ALE-IV4314A	Black/Black	Black	50 lbs.	Carton	<del>499.00</del>
---	-------------	-------------	-------	---------	--------	-------------------

## Guest Stacking Chair

Coordinate mesh chair for training, conference, or waiting rooms.

- Cool breathable mesh back upholstery stacks up to five high.
- Includes both glides for fixed use and casters for mobility.
- Provides long lasting support.
- Manufacturer's limited five-year warranty.
- Contains 5% post-consumer recycled content, 20% total recycled content.
- Meets or Exceeds ANSI/BIFMA Standards. ♻️ ♻️ ♻️

ID No.	Seat/Back Color	Base Color	Shpg. Wt.	Unit	Price
--------	-----------------	------------	-----------	------	-------

### B MESH GUEST STACK CHAIR

Supports up to 275 lbs.  
Seat: 18.13" × 18.88". Back: 20.88" × 17.75". Overall height: 36.25".

4	ALE-EL4314	Black/Black	Black	27 lbs.	Each	<del>305.00</del>
---	------------	-------------	-------	---------	------	-------------------



## Alera® Eikon Series

Contemporary breathable, vented back.

- Contoured mesh back for lumbar support with cushioned mesh seat.
- Durable steel frame with textured matte black finish.
- Great for use as guest seating or in training rooms.
- Some assembly required; just add glides for fixed use or casters for mobility.
- Stacks up to four high (two chairs per carton).
- Manufacturer's limited five-year warranty.
- Meets or Exceeds ANSI/BIFMA Standards. ♻️

ID No.	Seat/Back Color	Base Color	Shpg. Wt.	Qty.	Unit	Price
--------	-----------------	------------	-----------	------	------	-------

### C EIKON SERIES STACKING MESH GUEST CHAIR

Supports up to 275 lbs.  
Seat: 18.5" × 18.5". Back: 17.75" × 11.25". Overall height: 33.5".

5	ALE-EK43ME10B	Black/Black	Black	48 lbs.	2 Carton	<del>575.00</del>
---	---------------	-------------	-------	---------	----------	-------------------

## Alera® Continental Series Stack Chair

A smart stack chair for the office, conference room, auditorium or breakroom.

- Modern molded plastic chair with durable metal frame withstands heavy use, resists scratching and denting.
- Easy to clean.
- Flexi back adjusts for comfort based on user weight and provides lumbar support.
- Stacks neatly up to 12 high (four chairs per carton).
- Fully assembled.
- Manufacturer's limited five-year warranty.
- Meets or Exceeds ANSI/BIFMA Standards.

ID No.	Seat/Back Color	Base Color	Shpg. Wt.	Qty.	Unit	Price
--------	-----------------	------------	-----------	------	------	-------

### D PLASTIC PERFORATED BACK STACK CHAIR

Supports up to 275 lbs.  
Seat: 16.88" × 17.75". Back: 17.13" × 15.13". Overall height: 31.5".

6	ALE-SC6546	Charcoal Gray/Charcoal Gray	Gunmetal Gray	49 lbs.	4 Carton	<del>650.00</del>
---	------------	-----------------------------	---------------	---------	----------	-------------------





Shown with HON Huddle Multipurpose Tables.

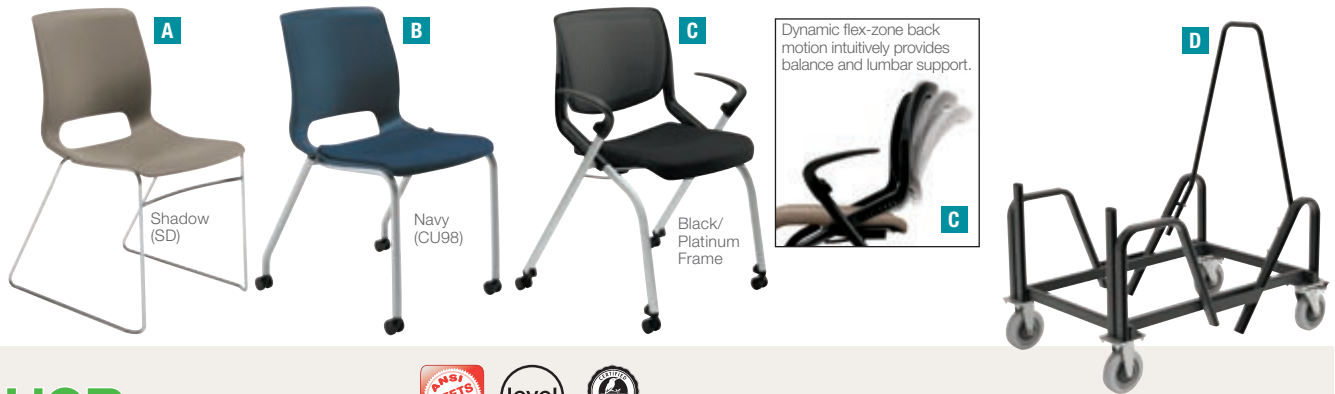

## HON Motivate® Seating

Adapt. React. Motivate.

- Ideal for collaborative areas serving multiple functions.
- Advanced contours of the seat and back move with the body to reduce pressure points.
- Stacking capability makes the most of your space.
- Backed by the HON Full Lifetime Warranty.
- Contains 5% pre-consumer recycled content, 18% post-consumer recycled content.
- Level 2 Certified; Meets or exceeds ANSI/BIFMA Standards; SCS Indoor Advantage Gold Certified.



ID No.	Seat/Back Color	Base Color	Shpg. Wt.	Qty.	Unit	Price
--------	-----------------	------------	-----------	------	------	-------

### A HIGH-DENSITY STACKING CHAIR

Stacks up to 12 high. Supports up to 300 lbs.  
Seat: 18¼" × 17¼". Back: 17¼" × 18". Overall height: 32¼".

1	HON-MS101ON	Onyx	Chrome	68 lbs.	4	Carton	<del>609.00</del>
2	HON-MS101RE	Regatta	Chrome	68 lbs.	4	Carton	<del>609.00</del>
3	HON-MS101SD	Shadow	Chrome	68 lbs.	4	Carton	<del>609.00</del>

ID No.	Finish	Shpg Wt.	Qty.	Unit	Price
--------	--------	----------	------	------	-------

### B PLATINUM FRAME FOUR-LEG STACKING CHAIR

Stacks up to six high. Supports up to 300 lbs.  
Seat: 18" × 18". Back: 17" × 18". Overall height: 32¼".

#### Fabric Upholstered Seat

4	HON-MG201CU10	Black/Onyx	40 lbs.	2	Carton	<del>674.00</del>
5	HON-MG201CU98	Navy/Regatta	41 lbs.	2	Carton	<del>674.00</del>
6	HON-MG201CU24	Shadow/Morel	40 lbs.	2	Carton	<del>674.00</del>

#### Plastic Seat

7	HON-MG101ON	Onyx	26 lbs.	2	Carton	<del>548.00</del>
---	-------------	------	---------	---	--------	-------------------

### C NESTING/STACKING FLEX-BACK CHAIR

Breathable ilira-stretch knit back conforms to the spine. Stackable up to four high. Supports up to 300 lbs. Seat: 17" × 17½". Back: 19½" × 18½". Overall height: 34".

8	HON-MN202ONCU10	Black/Black	26 lbs.	1	Each	<del>644.00</del>
9	HON-MN212ONCU10	Black/Onyx	26 lbs.	1	Each	<del>644.00</del>
10	HON-MN202SDCU24	Morel/Shadow	26 lbs.	1	Each	<del>644.00</del>

### D CART FOR HIGH-DENSITY STACKING CHAIRS

Store and transport chairs quickly and easily with this durable steel cart; holds up to 40 Motivate® high-density stacking chairs. Greater freedom of mobility with four-caster base. 21¾"W × 34¼"D × 36¾"H.

11	HON-MSCART	Black	40 lbs.		Each	<del>465.00</del>
----	------------	-------	---------	--	------	-------------------

In-Stock Finish In-Stock Upholstery



Onyx (ON) Black (CU10)

Special Order Finishes



Regatta (RE) Shadow (SD)

Special Order Upholstery



Navy (CU98) Morel (CU24)



Requires additional lead time and cannot be returned.

# Seating Stacking

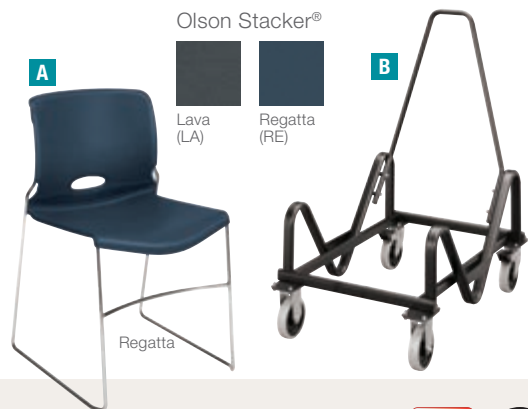



**HON**

## Olson Stacker® High Density Chairs

Easy-to-transport stacking chair goes wherever you go.



- Built-in lumbar support for comfort.
- Convenient grip in back for easy transport.
- Solid frame for added strength.
- Stack 12 high freestanding or 40 high with optional cart.
- Backed by the HON Full Lifetime Warranty.
- Contains 3% pre-consumer recycled content, 38% post-consumer recycled content.
- Level 2 Certified; Meets or Exceeds ANSI/BIFMA Standards; SCS Indoor Advantage Gold Certified.   

ID No.	Seat/Back Color	Base Color	Shpg. Wt.	Qty.	Unit	Price
<b>A OLSON STACKER® HIGH DENSITY CHAIR</b>						
Supports up to 300 lbs. Seat: 17.75" x 18.25". Back: 17.5" x 16.25". Overall height: 30.63".						
1	HON-4041LA	Lava/Lava	Chrome	57 lbs.	4	Carton <del>697.00</del>
2	HON-4041RE	Regatta/Regatta	Chrome	57 lbs.	4	Carton <del>697.00</del>



ID No.	Finish	W x D x H	Shpg. Wt.	Unit	Price
<b>B CART</b>					
Fits through a standard 6'8" door. Holds up to 40 Olson Stacker® Chairs. Backed by the HON Full Lifetime Warranty.  					
3	HON-4043T	Black	21¾" x 35½" x 37"	40 lbs.	Each <del>486.00</del>

## GuestStacker® High Density Chairs

Active seating for active spaces.

- Waterfall edge maximizes leg support.
- Molded to fit body.
- Lumbar support to reduce back fatigue.
- Wallsaver design allows chair clearance when frame rests against baseboard.
- Stack six high freestanding or 28 high with optional cart.
- Button glides help protect flooring.
- Four chairs per carton.
- Backed by the HON Full Lifetime Warranty.
- Contains 8% pre-consumer recycled content, 60% post-consumer recycled content.
- Level 2 Certified; Meets or Exceeds ANSI/BIFMA Standards; SCS Indoor Advantage Gold Certified.   

ID No.	Seat/Back Color	Base Color	Shpg. Wt.	Qty.	Unit	Price
<b>C GUESTSTACKER® HIGH DENSITY CHAIRS</b>						
Supports up to 300 lbs. Seat: 18" x 19". Back: 20" x 11". Overall height: 31".						
4	HON-4031LAT	Lava/Lava	Black	51 lbs.	4	Carton <del>621.00</del>
5	HON-4031ONT	Onyx/Onyx	Black	51 lbs.	4	Carton <del>621.00</del>
6	HON-4031RET	Regatta/Regatta	Black	51 lbs.	4	Carton <del>621.00</del>

ID No.	Finish	W x D x H	Shpg. Wt.	Unit	Price
<b>D CART</b>					
Fits through a standard 6'8" door. Holds up to 28 GuestStacker® Chairs. Backed by the HON Full Lifetime Warranty.  					
7	HON-4033T	Black	21¾" x 35½" x 37¾"	40 lbs.	Each <del>520.00</del>

Scatter™ Series

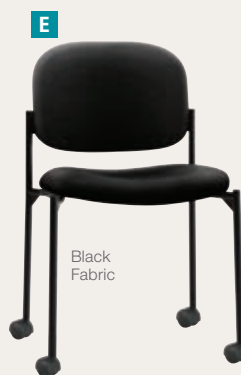

## Scatter™ Series Guest Chairs

Discover excellence without expense.

- Contoured seat and back provide ergonomic support and comfort.
- Tubular steel frame stands up to frequent handling.
- Includes casters and glides.
- Stacks up to four high for quick and easy rearrangement in multipurpose or common areas.
- Backed by the HON Limited Five-Year Warranty. 

ID No.	Seat/Back Color	Base Color	Shpg. Wt.	Unit	Price
<b>E STACKING ARMLESS GUEST CHAIR</b>					
Supports up to 250 lbs. Seat: 19" x 17.5". Back: 18.5" x 14.75". Overall height: 32.75".					
<b>SofThread™ Leather</b>					
8	BSX-VL606SB11	Black/Black	Black	16 lbs.	Each <del>476.00</del>
<b>Fabric</b>					
9	BSX-VL606VA10	Black/Black	Black	16 lbs.	Each <del>446.00</del>
10	BSX-VL606VA19	Charcoal/Charcoal	Black	16 lbs.	Each <del>446.00</del>
11	BSX-VL606VA90	Navy/Navy	Black	16 lbs.	Each <del>446.00</del>
<b>F STACKING GUEST CHAIR WITH ARMS</b>					
Arms promote relaxed sitting. Supports up to 250 lbs. Seat: 19" x 17.5". Back: 18.5" x 14.75". Overall height: 32.75".					
<b>SofThread™ Leather</b>					
12	BSX-VL616SB11	Black/Black	Black	18 lbs.	Each <del>494.00</del>
<b>Fabric</b>					
13	BSX-VL616VA10	Black/Black	Black	18 lbs.	Each <del>464.00</del>
14	BSX-VL616VA19	Charcoal/Charcoal	Black	18 lbs.	Each <del>464.00</del>
15	BSX-VL616VA90	Navy/Navy	Black	18 lbs.	Each <del>464.00</del>

Sorrento Series  
Black



Oversize Stack Chairs  
Black

Continental Series  
Black



## Alera® Sorrento Series Ultra

Ultra-cushioned seat and back provide enhanced comfort.

- Ideal for offices, lounges, conference rooms, and meeting houses.
- PVC-free faux-leather upholstery looks great and is a snap to clean.
- Strong steel base and straight legs ensure long-lasting durability.
- Stacks up to five high.
- Manufacturer's limited five-year warranty.
- Meets or Exceeds ANSI/BIFMA Standards.

ID No.	Seat/Back Color	Base Color	Shpg. Wt.	Qty.	Unit	Price
--------	-----------------	------------	-----------	------	------	-------

### A ULTRA-CUSHIONED STACKING GUEST CHAIR

Supports up to 275 lbs.  
Seat: 20.88" × 19.88". Back: 20.13" × 12.88". Overall height: 33.88".

#### Stacking Guest Chair with Ultra Cushion

1	ALE-UT6816	Black/Black	Black	46 lbs.	2	Carton	<del>445.00</del>
---	------------	-------------	-------	---------	---	--------	-------------------

## Alera® Sorrento Series

Perfect for waiting areas, conference rooms or guest seating.

- Durable and stylish black faux leather upholstery is PVC-free.
- Cushioned seat and base with sturdy black straight steel legs.
- Stacks up to five high.
- Manufacturer's limited five-year warranty.
- Contains 5% post-consumer recycled content, 30% total recycled content.
- Meets or Exceeds ANSI/BIFMA Standards.

ID No.	Seat/Back Color	Base Color	Shpg. Wt.	Qty.	Unit	Price
--------	-----------------	------------	-----------	------	------	-------

### B STACKING GUEST CHAIR

Supports up to 275 lbs.  
Seat: 17.38" × 18.5". Back: 17.75" × 11.63". Overall height: 31.88".

#### Stacking Guest Chair with Standard Cushion

2	ALE-ST6716A	Black/Black	Black	37 lbs.	2	Carton	<del>299.00</del>
---	-------------	-------------	-------	---------	---	--------	-------------------

#### Armless—Armless

3	ALE-ST6716	Black/Black	Black	37 lbs.	2	Carton	<del>249.00</del>
---	------------	-------------	-------	---------	---	--------	-------------------

## Alera® Continental Series Stacking Chairs

An office essential!

- Convenient, space-saving chairs stack up to twelve high when not in use.
- Padded seat and back with durable acrylic upholstery for comfort and long wear.
- Designed for comfort with a waterfall seat and contoured back.
- Sturdy black tubular steel frame for strength and stability.
- Manufacturer's limited five-year warranty.
- Meets or Exceeds ANSI/BIFMA Standards.

ID No.	Seat/Back Color	Base Color	Shpg. Wt.	Qty.	Unit	Price
--------	-----------------	------------	-----------	------	------	-------

### C STACKING GUEST CHAIR

Supports up to 250 lbs.  
Seat: 18.88" × 16.38". Back: 19.63" × 13.75". Overall height: 30.38".

4	ALE-SC67FA10B	Black/Black	Black	82 lbs.	4	Carton	<del>610.00</del>
---	---------------	-------------	-------	---------	---	--------	-------------------

## Oversize Stack Chairs

Heavy-duty chair with built-in lumbar support is designed to accommodate larger guests.

- Extra-wide seat with waterfall edge has a 3½" foam cushion for all-day comfort.
- Durable 18 gauge, 1" steel frame with front and back stretcher bars for added strength.
- Stacks up to 5 high for space-efficient storage.
- Great for healthcare facilities, dining halls, guest seating or any multi-use application where comfort and durability are needed.
- Manufacturer's limited five-year warranty.
- Contains 30% post-consumer recycled content, 30% total recycled content.
- Meets or Exceeds ANSI/BIFMA Standards.

ID No.	Seat/Back Color	Base Color	Shpg. Wt.	Qty.	Unit	Price
--------	-----------------	------------	-----------	------	------	-------

### D OVERSIZE STACK CHAIR WITH FIXED PADDED ARMS

Supports up to 500 lbs.  
Seat: 20.5" × 15.5". Back: 20" × 19.75". Overall height: 35.5".

#### Vinyl Upholstery—Vinyl Upholstery

5	ALE-BT6516	Black/Black	Black	50 lbs.	2	Carton	<del>645.00</del>
---	------------	-------------	-------	---------	---	--------	-------------------

### E OVERSIZE STACK CHAIR WITHOUT ARMS

Supports up to 500 lbs. Seat: 20.5" × 15.5". Back: 20" × 19.75". Overall height: 35.5".

#### Vinyl Upholstery—Vinyl Upholstery

6	ALE-BT6616	Black/Black	Black	46 lbs.	2	Carton	<del>595.00</del>
---	------------	-------------	-------	---------	---	--------	-------------------

Prices subject to change without notice.  
Visit our website for the latest pricing and product information.

# Seating Stacking

## Instigate™ Series



A



Black



B

Black



C

Black



### All In The Details

Frame cover disperses pressure when stacking to prevent imprints on the chair below.

# HON.

## Instigate™ Series Stacking Chairs

Discover excellence without expense.

- Double cross bar frame increases strength and durability.
- Frame cover disperses pressure to prevent imprints when stacking.
- Contoured mesh back provides ergonomic fit and support.
- Tailored soft fabric seat with layered foam provides all-day comfort.
- Wall-saver design keeps the back from scraping against paint or wall coverings.
- Stacks up to four high on the floor for quick rearrangement in multi-purpose rooms.
- Warranted for users up to 250 lbs.
- Backed by the HON Limited Five-Year Warranty.

ID No.	Seat/Back Color	Base Color	Shpg. Wt.	Qty.	Unit	Price
--------	-----------------	------------	-----------	------	------	-------

### A VL508 MESH BACK MULTI-PURPOSE CHAIR

Supports up to 250 lbs.  
Seat: 19" x 18". Back: 18" x 19". Overall height: 36".

1	BSX-VL508ES10	Black/Black	Black	19 lbs.	1	Each	<del>242.00</del>
---	---------------	-------------	-------	---------	---	------	-------------------

### B VL518 MESH BACK MULTI-PURPOSE CHAIR WITH ARMS

Fixed arms provide added comfort. Supports up to 250 lbs.  
Seat: 19" x 18". Back: 18" x 19". Overall height: 36".

2	BSX-VL518ES10	Black/Black	Black	23 lbs.	1	Each	<del>236.00</del>
---	---------------	-------------	-------	---------	---	------	-------------------

## Instigate™ Mesh Back Multi-Purpose Stools

Breathable mesh back conforms to the upper body for added comfort.

- Waterfall seat edge promotes better leg circulation.
- Tailored seat features multiple layers of foam cushioning to reduce pressure points.
- Multipurpose stool design accommodates a wide variety of spaces and applications.
- Wall-saver leg design keeps the back of the chair from scratching adjacent walls or cabinets.
- Polyester fabric is abrasion- and stain-resistant.
- Backed by the HON Limited Five-Year Warranty.
- Meets or Exceeds ANSI/BIFMA Standards and ISTA Performance Standards.

ID No.	Seat/Back Color	Base Color	Shpg. Wt.	Qty.	Unit	Price
--------	-----------------	------------	-----------	------	------	-------

### C MESH BACK CAFE-HEIGHT STOOL

Warranted for users up to 250 lbs.  
Seat: 20" x 18". Back: 17" x 19". Overall height: 50".

3	BSX-VL528ES10	Black/Black	Black	40 lbs.	2	Carton	<del>599.00</del>
---	---------------	-------------	-------	---------	---	--------	-------------------



D

Black (BL)



Vy™ Series

Black (BL)



E

Black (BL)

SAFCO™

## Vy™ Series Stack Chairs

350 lb. weight capacity.

- Wall saver design to help ensure no wall scrapes or damage.
- Handle cut-out in back for easy transport.
- Stacks up to 12 high on the floor and 18 high on a chair cart.
- Steel powder coat frame with silver finish.
- Manufacturer's limited lifetime warranty.
- GREENGUARD Certified; Meets or Exceeds ANSI/BIFMA Standards.

ID No.	Seat/Back Color	Base Color	Shpg. Wt.	Qty.	Unit	Price
--------	-----------------	------------	-----------	------	------	-------

### D STACK CHAIR

Supports up to 350 lbs.  
Seat: 18.5" x 17". Back: 19.5" x 16". Overall height: 32.5".

4	SAF-4292BL	Black/Black	Silver	59 lbs.	2	Carton	<del>428.00</del>
---	------------	-------------	--------	---------	---	--------	-------------------

### E SLED BASE BISTRO CHAIR

Supports up to 350 lbs.  
Seat: 19.5" x 18". Back: 19.5" x 15.75". Overall height: 45".

5	SAF-4295BL	Black/Black	Silver	69 lbs.	1	Each	<del>284.00</del>
---	------------	-------------	--------	---------	---	------	-------------------



# HON.



## Accommodate® Series

**Durable. Comfortable. Flexible.**

- Lightweight, maneuverable frame is ideal for multi-purpose spaces, cafes and common areas.
- Seat cushion is made of high-density molded foam that is designed to last longer.
- Comfort contours in the seat back cradle the spine.
- Waterfall seat edge promotes better leg circulation.
- Guest chairs ship with both casters and glides.
- Tube rolled steel frame provides a sturdy foundation.
- Warranted for users up to 300 lbs.
- Backed by the HON Full Lifetime Warranty.
- Level 2 Certified; Meets or Exceeds ANSI/BIFMA Standards; Meets or Exceeds ISTA Standards; SCS Indoor Advantage Gold Certified.



Shown in alternate fabric. Contact us for details.



ID No.	Seat/Back Color	Base Color	Shpg. Wt.	Qty.	Unit	Price
--------	-----------------	------------	-----------	------	------	-------

### A GUEST CHAIR

Stacks up to four high on the floor to save space when not in use. Ships with both casters and glides. Ships two per carton. Supports up to 300 lbs.  
Seat: 17½" × 20¾". Back: 20" × 16¼". Overall height: 32".

**Vinyl**—Armless.

1	HON-SGS6NBUR10B	Black	Black	56 lbs.	2	Carton	794.00
---	-----------------	-------	-------	---------	---	--------	--------

**Vinyl**—Fixed arms provide additional upper body support.

2	HON-SGS6FBUR10B	Black	Black	56 lbs.	2	Carton	854.00
---	-----------------	-------	-------	---------	---	--------	--------

**Fabric**—Armless.

3	HON-SGS6NBCU10B	Black	Black	56 lbs.	2	Carton	794.00
---	-----------------	-------	-------	---------	---	--------	--------

4	HON-SGS6NBCU98B	Navy	Black	50 lbs.	2	Carton	794.00
---	-----------------	------	-------	---------	---	--------	--------

**Fabric**—Fixed arms provide additional upper body support.

5	HON-SGS6FBCU10B	Black	Black	56 lbs.	2	Carton	854.00
---	-----------------	-------	-------	---------	---	--------	--------

6	HON-SGS6FBCU98B	Navy	Black	50 lbs.	2	Carton	854.00
---	-----------------	------	-------	---------	---	--------	--------

### B CAFÉ STOOL

Ideal for cafeteria and standing height worksurfaces. Fixed footring provides additional lower body support. Supports up to 300 lbs.  
Seat: 17½" × 20¾". Back: 20" × 16¼". Overall height: 45".

**Vinyl**—Armless.

7	HON-SCS2NEUR10B	Black	Black	39 lbs.	1	Each	492.00
---	-----------------	-------	-------	---------	---	------	--------

**Vinyl**—Fixed arms provide additional upper body support.

8	HON-SCS2FEUR10B	Black	Black	39 lbs.	1	Each	522.00
---	-----------------	-------	-------	---------	---	------	--------

**Fabric**—Armless.

9	HON-SCS2NECU10B	Black	Black	39 lbs.	1	Each	492.00
---	-----------------	-------	-------	---------	---	------	--------

10	HON-SCS2NECU98B	Navy	Black	38 lbs.	1	Each	492.00
----	-----------------	------	-------	---------	---	------	--------

**Fabric**—Fixed arms provide additional upper body support.

11	HON-SCS2FECU10B	Black	Black	39 lbs.	1	Each	522.00
----	-----------------	-------	-------	---------	---	------	--------

12	HON-SCS2FECU98B	Navy	Black	38 lbs.	1	Each	522.00
----	-----------------	------	-------	---------	---	------	--------

\* HON-SGS6NBCU98B, HON-SGS6FBCU98B, HON-SCS2FECU98B, HON-SCS2NECU98B—Contains 21% post-consumer recycled content, 31% total recycled content.



Guest Chairs ship with both casters and glides

### Upholstery

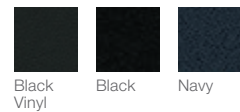

Requires additional lead time and cannot be returned.



20-MF-L-FCL

Prices subject to change without notice. Visit our website for the latest pricing and product information.

# Seating Stacking



A

Blue  
(BU)

Stacking Chair



Black (BL) Blue (BU) Charcoal (CH)



B



Charcoal  
(7)



D

Black  
(1)



Rough N Ready



Black (1) Charcoal (7)



Cart supports up to 15 Contour Chairs (not included)



## Stacking Chair

Generous, contoured polypropylene seat and back.

- Tubular steel frame with black powder coat finish for durability.
- Manufacturer's limited lifetime warranty.
- Stacks up to 15 high for efficient storage.
- GREENGUARD Certified.

ID No.	Seat/Back Color	Base Color	Shpg. Wt.	Qty.	Unit	Price
--------	-----------------	------------	-----------	------	------	-------

### A STACKING CHAIR

Supports up to 250 lbs.

Seat: 18.5" x 16.25". Back: 18.25" x 12.75". Overall height: 30.5".

1	SAF-4185BL	Black/Black	Black	59 lbs.	4	Carton	432.00
2	SAF-4185BU	Blue/Blue	Black	59 lbs.	4	Carton	432.00
3	SAF-4185CH	Charcoal/Charcoal	Black	59 lbs.	4	Carton	432.00

ID No.	W x D x H	Finish	Shpg. Wt.	Unit	Price
--------	-----------	--------	-----------	------	-------

### B STACKING CHAIR CART

Heavy-duty steel dolly easily supports up to seven Stacking Chairs, sold separately. Manufacturer's limited lifetime warranty.

4	SAF-4188	23½" x 23½" x 4½"	Black	25 lbs.	Each	453.00
---	----------	-------------------	-------	---------	------	--------



## Rough N Ready Stack Chairs

Lightweight, durable and sturdy.

- Ergonomically designed for comfort with an extra-wide seat and back.
- Blow molded, high-density polyethylene is dent- and scratch-resistant.
- Heavy-gauge, powder-coated steel tube frame.
- Non-mar feet protect floor.
- Four chairs per carton.
- Manufacturer's limited 15-year warranty.
- Contains 35% total recycled content.
- Meets or Exceeds ANSI/BIFMA Standards.

ID No.	Seat/Back Color	Base Color	Shpg. Wt.	Qty.	Unit	Price
--------	-----------------	------------	-----------	------	------	-------

### C ORIGINAL STACK CHAIR

Stacks up to 8 high. Supports up to 500 lbs.

Seat: 15.5" x 17.5". Back: 15.5" x 16". Overall height: 32.25".

5	ICE-64111	Black/Black	Silver	62 lbs.	4	Carton	438.95
6	ICE-64117	Charcoal/Charcoal	Silver	62 lbs.	4	Carton	438.95

### D BIG & TALL STACK CHAIR

Stacks up to 6 high. Supports up to 500 lbs.

Seat: 24" x 20". Back: 24" x 18". Overall height: 32".

7	ICE-64121	Black/Black	Silver	95 lbs.	4	Carton	695.95
8	ICE-64127	Charcoal/Charcoal	Silver	95 lbs.	4	Carton	695.95



## Vinyl Stacking Chairs

Stacks up to 12 high.

- Padded seat and back with vinyl upholstery.
- Exceptionally strong tubular steel structure with corrosion-resistant powder-coat finish.
- Grab-and-go handles for easy positioning and stacking.
- Bumpers protect walls from being scratched when chairs are stacked.
- Non-marring foot glides protect floors.
- Four chairs per carton.
- Manufacturer's limited five-year warranty.
- Meets or Exceeds ANSI/BIFMA Standards.

ID No.	Seat/Back Color	Base Color	Shpg. Wt.	Qty.	Unit	Price
--------	-----------------	------------	-----------	------	------	-------

### E VINYL STACKING CHAIRS

Square back. Powder-coated frame. Supports up to 250 lbs.

Seat: 15.75" x 15.38". Back: 13" x 12.38". Overall height: 32.88".

#### Black Frame

9	ALE-SC68VY10B	Black/Black	Black	67 lbs.	4	Carton	565.00
---	---------------	-------------	-------	---------	---	--------	--------

ID No.	W x D	Finish	Shpg. Wt.	Unit	Price
--------	-------	--------	-----------	------	-------

### F STACKING CHAIR DOLLY

Sturdy steel powder coated dolly with ¾" raised edge keeps chairs from sliding off. Four casters. Holds 10-12 chairs. Manufacturer's limited five-year warranty.

10	ALE-SCCART	22½" x 22½"	Black	14 lbs.	Each	99.00
----	------------	-------------	-------	---------	------	-------

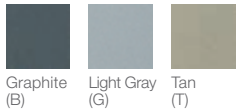
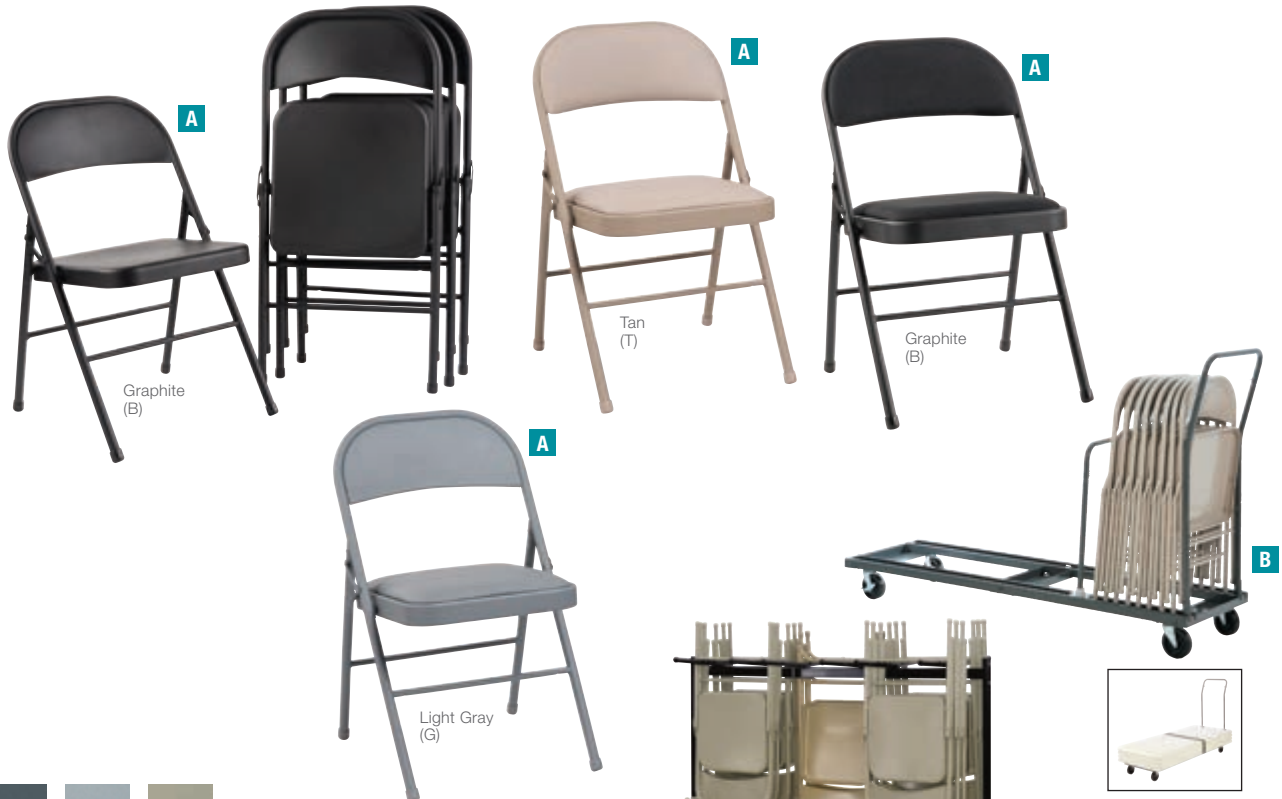

## Steel Folding Chairs

**An office necessity!**

- Sturdy tubular steel frame with double braced construction.
- Textured powder-coated finish resists smudges and fingerprints.
- Foot caps help protect flooring.
- Manufacturer's limited five-year warranty.
- Meets or Exceeds ANSI/BIFMA Standards.



ID No.	Seat/Back Color	Base Color	Shpg. Wt.	Qty.	Unit	Price
<b>A STEEL FOLDING CHAIR</b>						
Supports up to 300 lbs. Seat: 15.75" x 15.5". Back: 18" x 7.5". Overall height: 30.5".						
<b>All Steel</b> —Easy to clean and long lasting.						
1	ALE-FCMT4B	Graphite/ Graphite	Graphite	46 lbs.	4	Carton <del>198.00</del>
2	ALE-FCMT4G	Light Gray/ Light Gray	Light Gray	46 lbs.	4	Carton <del>198.00</del>
3	ALE-FCMT4T	Tan/ Tan	Tan	46 lbs.	4	Carton <del>198.00</del>
<b>With Vinyl Padded Seat</b> —With Vinyl Padded Seat						
4	ALE-FCPC5B	Graphite/ Graphite	Graphite	48 lbs.	4	Carton <del>232.00</del>
5	ALE-FCPC5G	Light Gray/ Light Gray	Light Gray	48 lbs.	4	Carton <del>232.00</del>
6	ALE-FCPC5T	Tan Tan	Tan	48 lbs.	4	Carton <del>232.00</del>
<b>With Vinyl Padded Seat and Back</b> —With Vinyl Padded Seat						
7	ALE-FCPD6B	Graphite/ Graphite	Graphite	50 lbs.	4	Carton <del>243.00</del>
8	ALE-FCPD6G	Light Gray/ Light Gray	Light Gray	50 lbs.	4	Carton <del>243.00</del>
9	ALE-FCPD6T	Tan/ Tan	Tan	50 lbs.	4	Carton <del>243.00</del>
<b>With Fabric Padded Seat and Back</b> —With Vinyl Padded Seat						
10	ALE-FCPF7B	Graphite/ Graphite	Graphite	51 lbs.	4	Carton <del>259.00</del>
11	ALE-FCPF7G	Light Gray/ Light Gray	Light Gray	51 lbs.	4	Carton <del>259.00</del>
12	ALE-FCPF7T	Tan/ Tan	Tan	51 lbs.	4	Carton <del>259.00</del>



## Adjustable Chair & Table Carts

**Adjustable to accommodate most folding designs.**

- Durable steel.
- Reliable casters.

ID No.	Finish	W x D	Shpg. Wt.	Unit	Price
<b>B CHAIR/TABLE CART</b>					
Adjustable to accommodate most styles of folding chairs/tables. Convenient steel construction cart can be used as both a folding chair cart or table cart. Adjustable U-bar keeps folding chairs from falling over during transport. U-bar is removable for table storage. Heavy-duty casters; two locking. Holds up to 600 lbs. Includes safety strap.					
13	ALE-FTCART	Black	20¼" x 50¾" to 75¾"	65 lbs.	Each <del>555.00</del>



## Two-Tier Chair Cart

**A space-saving solution.**

- Holds up to 84 folding chairs.

ID No.	Finish	W x D x H	Shpg. Wt.	Unit	Price
<b>C TWO-TIER CHAIR CART</b>					
14	SAF-4199BL	Black	64½" x 33½" x 70¼"	99 lbs.	Each <del>776.00</del>

Prices subject to change without notice.  
Visit our website for the latest pricing and product information.



White

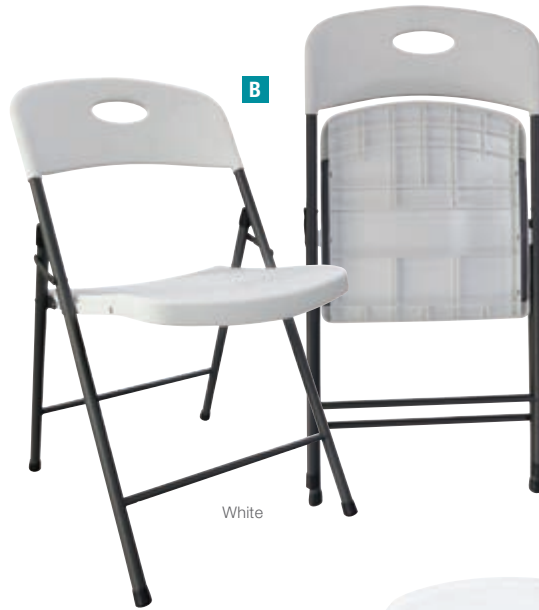

White



White



Charcoal



Platinum



## Molded Resin Folding Chairs

Perfect for quick setups with large groups, indoors or out.

- Contoured, molded resin seat and back for ergonomic comfort.
- Heavy-duty steel frame features a corrosion-resistant powder-coat finish.
- Folds flat for compact storage.
- Non-marring foot caps protect floor surfaces.
- Manufacturer's limited five-year warranty.
- Meets or Exceeds ANSI/BIFMA Standards.

ID No.	Seat/Back Color	Base Color	Shpg. Wt.	Qty.	Unit	Price
--------	-----------------	------------	-----------	------	------	-------

### A PREMIUM MOLDED PLASTIC RESIN FOLDING CHAIR

Extra-duty folding chair delivers added strength and durability. Deluxe size provides optimum comfort and support. Reliable for extended usage. Supports up to 250 lbs. Seat: 17.33" x 16". Back: x10.13" x 16.38". Back: 6.5" x 8.75". Overall height: to 33.38".

1	ALE-FR9302	White/ White	Dark Gray	51 lbs.	4	Carton	<del>345.00</del>
---	------------	--------------	-----------	---------	---	--------	-------------------

### B MOLDED PLASTIC RESIN FOLDING CHAIR

A classic chair for all occasions. U-brace design ensure stability and prevents racking. Supports up to 225 lbs. Seat: 15.75" x 16.38". Back: 6.5" x 8.75". Overall height: to 31".

2	ALE-FR9402	White/ White	Dark Gray	31 lbs.	4	Carton	<del>295.00</del>
---	------------	--------------	-----------	---------	---	--------	-------------------

### C BANQUET PLASTIC RESIN FOLDING CHAIR

Lightweight and convenient. U-brace frame ensures stability. Supports up to 225 lbs. Seat: 15.63" x 15.63". Back: 6.5" x 16.63". Overall height: to 31.5".

3	ALE-FR9502	White/ White	White	26 lbs.	4	Carton	<del>175.00</del>
---	------------	--------------	-------	---------	---	--------	-------------------



## Rough N Ready Folding Chair

Lightweight, yet stands up to frequent use!

- Extra-wide seat and back for added comfort.
- Heavy-duty powder-coated frame provides strength and stability.
- Manufacturer's limited 15-year warranty.
- Contains 35% total recycled content.
- Meets or Exceeds ANSI/BIFMA Standards. ♻️ ♻️

ID No.	Seat/Back Color	Base Color	Shpg. Wt.	Qty.	Unit	Price
--------	-----------------	------------	-----------	------	------	-------

### D FOLDING CHAIR

Supports up to 350 lbs. Seat: 18.75" x 21.5". Back: 18.75" x 20.25". Overall height: to 35.5".

#### Powder Coated Finish on Frame

4	ICE-64007	Charcoal/ Charcoal	Silver	15 lbs.	1	Each	<del>122.95</del>
5	ICE-64003	Platinum/ Platinum	Black	15 lbs.	1	Each	<del>122.95</del>





## Buying Guide Casters

Match your caster stem to the diagram

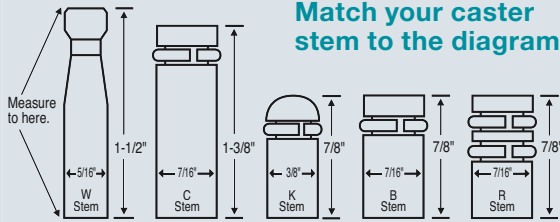

**Remove** a caster from the leg of your chair base.

**Match** the stem of your caster to the diagram. Select the correct stem length and diameter. (The stem tops can be flat or rounded—either will fit.)

**Determine** if the casters will be used on carpeting, hard floors or chair mats.

**For carpeting:** order hard wheel casters.

**For hard floors, linoleum (vinyl) or chair mats:** order soft wheel casters.



For use on carpeting:  
Order hard wheel casters.



For use on hard floors:  
Order soft wheel casters.



For use on linoleum (vinyl):  
Order soft wheel casters.



For use on chair mats:  
Order soft wheel casters.

Additional stem fasteners available by special order.



Convert office chairs with casters to stationary chairs.

High Profile

Low Profile



Prepacked with stem fasteners to attach to all metal base furniture.



C



D

Standard Neck  
Safety Casters



E

Oversized Neck



F

new

Problem Solving Products  
**Master**  
MANUFACTURING  
MASTER CASTER



### Master Caster/Master MFG

- Contemporary design, strength and performance make these replacement casters an excellent choice for office and home furnishings.
- All casters carry the manufacturer's guarantee against defects in material and workmanship.
- Manufacturer's limited lifetime warranty against defects in material and manufacturing.

ID No.	Stem	Wheel Tread	Qty.	Unit	Price
--------	------	-------------	------	------	-------

#### A BELL GLIDES

Convert office chairs with casters to stationary chairs without diminishing the chair height. For metal bases.

**High Profile**—2 $\frac{3}{16}$ " base diameter. Height (not including stem): 2 $\frac{5}{16}$ ".

1	MAS-70175	B	....	5	Set	<del>32.95</del>
---	-----------	---	------	---	-----	------------------

**Low Profile**—2" base diameter. Height (not including stem): 1 $\frac{3}{8}$ ".

2	MAS-70178	B	....	5	Set	<del>31.25</del>
---	-----------	---	------	---	-----	------------------

ID No.	Stem	Wheel Tread	Qty.	Unit	Price
--------	------	-------------	------	------	-------

#### B DELUXE CASTERS

Take the guesswork out of caster replacement. Each set includes five each:  $\frac{7}{16} \times \frac{7}{8}$  (B) Stems, and  $\frac{3}{8} \times \frac{7}{8}$  (K) stems. Choose hard nylon wheels for use on carpet or soft polyurethane-bonded wheels for hard floors and chair mats.

**Deluxe Duet Casters**—2" diameter dual wheel casters with full hood. Black. Weight rated 110 lbs. per caster wheel.

3	MAS-23622	B; K	Hard	5	Set	<del>44.95</del>
---	-----------	------	------	---	-----	------------------

4	MAS-23624	B; K	Soft	5	Set	<del>52.25</del>
---	-----------	------	------	---	-----	------------------

**Deluxe Futura Casters**—2 $\frac{9}{16}$ " diameter euro-style caster fits bases with 1- $\frac{1}{2}$ " dia. oversized necks to make the caster and base appear as one. Weight rated 120 lbs. per caster wheel.

5	MAS-23618	B; K	Hard	5	Set	<del>49.50</del>
---	-----------	------	------	---	-----	------------------

6	MAS-23620	B; K	Soft	5	Set	<del>57.00</del>
---	-----------	------	------	---	-----	------------------

#### C DELUXE FUTURA CASTERS

Nylon wheels for use on carpet. 120 lbs. per caster weight capacity.

7	MAS-23619	B; K	Hard	5	Set	<del>49.50</del>
---	-----------	------	------	---	-----	------------------

8	MAS-23621	B; K	Soft	5	Set	<del>57.00</del>
---	-----------	------	------	---	-----	------------------

#### D DUET CASTERS

For light to medium duty applications. 2" diameter dual wheel casters with full hood. Black. Weight rated 110 lbs. per caster wheel.

9	MAS-64426	C	Hard	5	Set	<del>40.70</del>
---	-----------	---	------	---	-----	------------------

10	MAS-64526	C	Soft	5	Set	<del>40.45</del>
----	-----------	---	------	---	-----	------------------

ID No.	Stem	Wheel Tread	Qty.	Unit	Price
--------	------	-------------	------	------	-------

#### E SAFETY CASTERS

Patented Roll Control® internal brake prevents wheels from rolling freely when user stands. Allows smooth effortless rolling while seated. 2" dia. dual wheels. Weight rated 100 lbs. per caster wheel.

#### Oversized Neck

11	MAS-64235	B	Hard	5	Set	<del>57.50</del>
----	-----------	---	------	---	-----	------------------

12	MAS-64335	B	Soft	5	Set	<del>64.75</del>
----	-----------	---	------	---	-----	------------------

#### Standard Neck

13	MAS-64234	B	Hard	5	Set	<del>59.75</del>
----	-----------	---	------	---	-----	------------------

14	MAS-64334	B	Soft	5	Set	<del>64.50</del>
----	-----------	---	------	---	-----	------------------



### Dual Wheel Hooded Casters

- High-performance casters are an excellent choice.
- Weight rated to 100 lbs. per caster wheel.
- Manufacturer's limited five-year warranty.
- Meets or Exceeds ANSI/BIFMA Standards.

ID No.	Stem	Wheel Tread	Qty.	Unit	Price
--------	------	-------------	------	------	-------

#### F DUAL WHEEL HOODED CASTERS

15	ALE-CASTERHT1	B	Hard	5	Set	<del>52.00</del>
----	---------------	---	------	---	-----	------------------

16	ALE-CASTERST2	B	Soft	5	Set	<del>57.00</del>
----	---------------	---	------	---	-----	------------------

Prices subject to change without notice.

Visit our website for the latest pricing and product information.

## Buying Guide Chair Mats



Carpet



Hard Floor

1. Determine flooring type—carpet or hard floor
2. Determine use—consider factors for frequency of use, weight placed on mat and type of flooring

For Carpet For Hard Floor

ALL DAY USE	FREQUENT USE	MODERATE USE	OCCASIONAL USE	ALL DAY USE
ALL DAY	6-8 Hrs.	4-6 Hrs.	0-4 Hrs.	ALL DAY
HEAVY	AVERAGE	AVERAGE	LIGHT	AVERAGE
HIGH PILE	MEDIUM PILE	LOW PILE	FLAT PILE	HARD FLOOR

### 3. Determine your carpet thickness

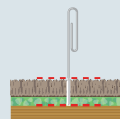

- Open one end of a paper clip.
- Insert paper clip into carpet and pad, pushing down to the sub-floor.
- Measure the portion of the paper clip that entered the carpet and pad, and then reference the guide below.



HIGH PILE



MEDIUM PILE



LOW PILE



FLAT PILE



HARD FLOOR

### 4. Measure your floor area to determine size and shape



Lipped



Square



Rectangular



Work-Station



A



B



C



#### A PREMIUM GLASS CHAIR MAT

Extremely durable, 1/4" thick, fully tempered recycled glass mat suitable for combined user and chair weights up to 1000 lbs. Nonstudded bottom surface for use on all pile carpets and hard floor surfaces. Exceptional clarity allows you to show off any flooring, including carpet, tile, hardwood and area rugs. Provides maximum, long-lasting durability to protect flooring from caster wear, spills and heavy traffic. Smooth, easy-glide rolling surface resists indentations, providing effortless chair movement. Scratch-resistant surface cleans easily with any glass cleaner. Manufacturer's Limited Lifetime Product Replacement Warranty.

ID No.	Surface	Style	Overall (W × L)	Unit	Price
1 DEF-CMG70433646	Hard Floor; All Pile Carpets	Rectangular	36" × 46"	Each	299.95
2 DEF-CMG70434450	Hard Floor; All Pile Carpets	Rectangular	44" × 50"	Each	385.00
3 DEF-CMG70434860	Hard Floor; All Pile Carpets	Rectangular	48" × 60"	Each	459.00

#### B EXECUMAT INTENSIVE ALL DAY USE CHAIR MAT FOR PLUSH, HIGH PILE CARPETING

Sophisticated distinction for the demanding executive. High quality, heavy-weight protective vinyl chairmat engineered for exceptional performance. Extra-thick, intensive, all-day use chairmat for carpets over 1/2" thick. Smooth beveled edge for easy carpet to mat transition. Studded design secures mat from moving while protecting carpet from caster wear, spills and heavy traffic. Free and Clear® non-orthophthalate, non-cadmium formula promotes a healthy work environment while offering exceptional clarity and durability. GREENGUARD Gold Certified. Manufacturer's Limited Lifetime Product Replacement Warranty.

ID No.	Surface	Style	Overall (W × L)	Unit	Price
4 DEF-CM17233	High Pile	Lipped	45" × 53"	Each	269.79
5 DEF-CM17443F	High Pile	Rectangular	46" × 60"	Each	368.06

#### C ROLLAMAT FREQUENT USE CHAIR MAT FOR MEDIUM PILE CARPETING

Superior performance. Studded design secures mat from moving while protecting carpet from caster wear, spills and heavy traffic. Medium weight chair mat for frequent use on carpets up to 1/2" thick. Smooth beveled edge for easy carpet to mat transition. Free and Clear® non-orthophthalate, non-cadmium formula promotes a healthy work environment while offering exceptional clarity and durability. GREENGUARD Gold Certified. Manufacturer's Limited Lifetime Product Replacement Warranty.

ID No.	Surface	Style	Overall (W × L)	Unit	Price
<b>Flat Packed</b>					
6 DEF-CM15113	Medium Pile	Lipped	36" × 48"	Each	153.09
7 DEF-CM15233	Medium Pile	Lipped	45" × 53"	Each	181.54
8 DEF-CM15443F	Medium Pile	Rectangular	46" × 60"	Each	209.05



deflecto®

## A SUPERMAT FREQUENT USE CHAIR MAT FOR MEDIUM PILE CARPETING

A status statement for the mainstream specialist. Superior performance. Studded design secures mat from moving while protecting carpet from caster wear, spills and heavy traffic. Medium weight chair mat for frequent use on carpets up to ½" thick. Bottom studs provide superior gripping power on carpets. Free and Clear® non-orthophthalate, non-cadmium formula promotes a healthy work environment while offering exceptional clarity and durability. Manufacturer's Limited Lifetime Product Replacement Warranty. GREENGUARD Gold Certified.

ID No.	Surface	Style	Overall (W × L)	Unit	Price
<b>Flat Packed—Straight Edge</b>					
1	DEF-CM14142	Medium Pile	Rectangular	36" × 48"	Each <del>124.42</del>
2	DEF-CM14242	Medium Pile	Rectangular	45" × 53"	Each <del>141.47</del>
3	DEF-CM14432F	Medium Pile	Lipped	46" × 60"	Each <del>147.60</del>
4	DEF-CM14002K	Medium Pile	Workstation/Lipped	60" × 66"	Each <del>297.63</del>
<b>Flat Packed—Beveled Edge for easy carpet to mat transition.</b>					
5	DEF-CM14113	Medium Pile	Lipped	36" × 48"	Each <del>113.02</del>
6	DEF-CM14233	Medium Pile	Lipped	45" × 53"	Each <del>120.26</del>
7	DEF-CM14443F	Medium Pile	Rectangular	46" × 60"	Each <del>166.53</del>
<b>Rolled Packed</b>					
8	DEF-CM14113COM	Medium Pile	Lipped	36" × 48"	Each <del>113.02</del>
9	DEF-CM14242COM	Medium Pile	Rectangular	45" × 53"	Each <del>141.47</del>
10	DEF-CM14443FCOM	Medium Pile	Rectangular	46" × 60"	Each <del>166.53</del>

## B DURAMAT MODERATE USE CHAIR MAT FOR LOW PILE CARPETING

Light weight, durable performance for moderate use on carpets up to ¾" thick. Easy-glide rolling surface provides effortless chair movement. Studded design secures mat from moving while protecting carpet from caster wear, spills and heavy traffic. Free and Clear® non-orthophthalate, non-cadmium formula promotes a healthy work environment while offering exceptional clarity and durability. Manufacturer's Limited Lifetime Product Replacement Warranty. GREENGUARD Gold Certified.

ID No.	Surface	Style	Overall (W × L)	Unit	Price
<b>Flat Packed</b>					
11	DEF-CM13113	Low Pile	Lipped	36" × 48"	Each <del>79.60</del>
12	DEF-CM13233	Low Pile	Lipped	45" × 53"	Each <del>91.82</del>
13	DEF-CM13142	Low Pile	Rectangular	36" × 48"	Each <del>101.27</del>
14	DEF-CM13242	Low Pile	Rectangular	45" × 53"	Each <del>118.68</del>
15	DEF-CM13443F	Low Pile	Rectangular	46" × 60"	Each <del>124.04</del>
16	DEF-CM13433F	Low Pile	Lipped	46" × 60"	Each <del>122.71</del>
<b>Rolled Packed</b>					
17	DEF-CM13113COM	Low Pile	Lipped	36" × 48"	Each <del>79.60</del>
18	DEF-CM13443FCOM	Low Pile	Rectangular	46" × 60"	Each <del>124.04</del>

## C ECONOMAT OCCASIONAL USE CHAIR MAT FOR COMMERCIAL FLAT PILE CARPETING

Thinner, light weight chair mat for occasional use on carpets up to ¼" thick. Easy-glide rolling surface provides effortless chair movement. Studded design secures mat from moving while protecting carpet from caster wear, spills and heavy traffic. Free and Clear® non-orthophthalate, non-cadmium formula promotes a healthy work environment while offering exceptional clarity and durability. Classic straight edge finish. Manufacturer's Limited Lifetime Product Replacement Warranty. GREENGUARD Gold Certified.

ID No.	Surface	Style	Overall (W × L)	Unit	Price
<b>Flat Packed</b>					
19	DEF-CM11112	Flat Pile	Lipped	36" × 48"	Each <del>77.73</del>
20	DEF-CM11232	Flat Pile	Lipped	45" × 53"	Each <del>86.66</del>
21	DEF-CM11442F	Flat Pile	Rectangular	46" × 60"	Each <del>126.58</del>
<b>Rolled Packed</b>					
22	DEF-CM11112COM	Flat Pile	Lipped	36" × 48"	Each <del>77.73</del>
23	DEF-CM11242COM	Flat Pile	Rectangular	45" × 53"	Each <del>105.85</del>
24	DEF-CM11442FCOM	Flat Pile	Rectangular	46" × 60"	Each <del>126.58</del>

Prices subject to change without notice.  
Visit our website for the latest pricing and product information.

# Seating Mats

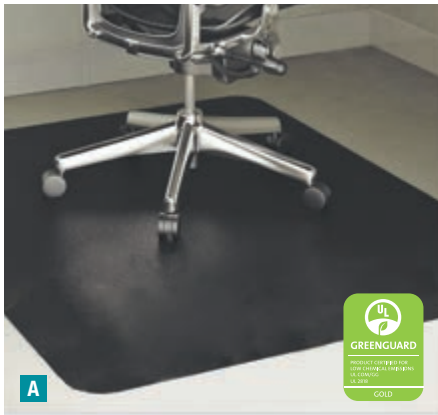

deflecto®

## A ECONOMAT NON-STUDED ALL DAY USE CHAIR MAT FOR HARD FLOORS

Non-studded design protects hard floor surfaces from caster wear, spills and heavy traffic. Ideal for all-day use on wood, tile, laminate and other hard floors (Not suitable for use on concrete floors). Easy-glide rolling surface provides effortless chair movement. Free & Clear® non-orthophthalate, non-cadmium formula promotes a healthy work environment while offering exceptional clarity and durability. Classic straight edge finish. Manufacturer's Limited Lifetime Product Replacement Warranty. GREENGUARD Gold Certified.

ID No.	Surface	Style	Overall (W x L)	Unit	Price
<b>Flat Packed</b>					
1	DEF-CM21112	Hard Floor	Lipped	36" x 48"	Each 81.94
2	DEF-CM2E142	Hard Floor	Rectangular	36" x 48"	Each 85.35
3	DEF-CM21232	Hard Floor	Lipped	45" x 53"	Each 99.63
4	DEF-CM2E242	Hard Floor	Rectangular	45" x 53"	Each 99.75
5	DEF-CM21442F	Hard Floor	Rectangular	46" x 60"	Each 128.93
6	DEF-CM2E432F	Hard Floor	Lipped	46" x 60"	Each 99.75
<b>Rolled Packed</b>					
7	DEF-CM2E442FCOM	Hard Floor	Rectangular	46" x 60"	Each 127.65
8	DEF-CM21242COM	Hard Floor	Rectangular	45" x 53"	Each 120.42
9	DEF-CM21112COM	Hard Floor	Lipped	36" x 48"	Each 81.88

A LERA.

## B STUDED CHAIR MAT FOR LOW PILE CARPET

Studded design secures mat from moving while protecting carpet from caster wear, spills and heavy traffic. Medium weight chair mat for frequent use on carpets up to 3/8" thick. Smooth beveled edge for easy carpet to mat transition. Free and Clear® non-orthophthalate, non-cadmium formula promotes a healthy work environment while offering exceptional clarity and durability. Manufacturer's Limited Lifetime Product Replacement Warranty. GREENGUARD Gold Certified.

ID No.	Surface	Style	Overall (W x L)	Unit	Price
10	ALE-MAT3648CLPL	Low Pile	Lipped	36" x 48"	Each 75.00
11	ALE-MAT4553CLPL	Low Pile	Lipped	45" x 53"	Each 85.00
12	ALE-MAT4660CLPR	Low Pile	Rectangular	46" x 60"	Each 107.00

## C STUDED CHAIR MAT FOR FLAT PILE CARPET

Thinner, lightweight chair mat for occasional use on carpets up to 1/4" thick. Easy-glide rolling surface provides effortless chair movement. Studded design secures mat from moving while protecting carpet from caster wear, spills and heavy traffic. Classic straight edge finish. Free and Clear® non-orthophthalate, non-cadmium formula promotes a healthy work environment while offering exceptional clarity and durability. Manufacturer's Limited Lifetime Product Replacement Warranty. GREENGUARD Gold Certified.

ID No.	Surface	Style	Overall (W x L)	Unit	Price
13	ALE-MAT3648CFPL	Flat Pile	Lipped	36" x 48"	Each 65.00
14	ALE-MAT4553CFPL	Flat Pile	Lipped	45" x 53"	Each 75.00
15	ALE-MAT4660CFPR	Flat Pile	Rectangular	46" x 60"	Each 97.00

## D NON-STUDED CHAIR MAT FOR HARD FLOOR

Non-studded design protects hard floor surfaces from caster wear, spills and heavy traffic. Ideal for use on wood, tile, laminate and other hard floors (Not suitable for use on concrete floors). Non-orthophthalate, non-cadmium formula promotes a healthy work environment. Classic straight edge finish. Manufacturer's Limited Lifetime Product Replacement Warranty. GREENGUARD Gold Certified.

ID No.	Surface	Style	Overall (W x L)	Unit	Price
16	ALE-MAT3648HFL	Hard Floor	Lipped	36" x 48"	Each 54.00
17	ALE-MAT4553HFL	Hard Floor	Lipped	45" x 53"	Each 65.00
18	ALE-MAT4660HFR	Hard Floor	Rectangular	46" x 60"	Each 85.00





E.S. ROBBINS

## A NATURAL ORIGINS® BIOBASED CHAIR MAT FOR CARPET

Clear chair mat made from renewable plant sources. Contains 26% USDA certified biobased content by weight. Phthalate-free and cadmium-free. Protects loop/berber style carpet up to ¾" thick including padding. Exclusive AnchorBar® cleats hold firmly in place, yet are gentle on carpet and fingers. Ideal for moderate use in home and office applications. Straight edge. Manufacturer's limited lifetime "No Crack Mat" warranty. GREENGUARD Certified; GREENGUARD Gold Certified; USDA Certified Biobased 26%.

ID No.	Surface	Style	Overall (W x L)	Unit	Price
1 ESR-141032	Low Pile	Lipped	36" x 48"	Each	99.31
2 ESR-141028	Low Pile	Rectangular	36" x 48"	Each	102.00
3 ESR-141042	Low Pile	Lipped	45" x 53"	Each	117.28
4 ESR-141052	Low Pile	Rectangular	46" x 60"	Each	135.24

## B NATURAL ORIGINS® BIOBASED CHAIR MAT FOR HARD FLOORS

Clear chair mat made from renewable plant sources. Contains 26% USDA certified biobased content by weight. Phthalate-free and cadmium-free. Protects hard floors like laminate, wood or tile. Ideal for light use in home and office applications. Straight edge. Manufacturer's limited one-year "No Crack Mat" warranty. GREENGUARD Certified; GREENGUARD Gold Certified; USDA Certified Biobased 26%.

ID No.	Surface	Style	Overall (W x L)	Unit	Price
5 ESR-143002	Hard Floor	Lipped	36" x 48"	Each	99.31
6 ESR-143007	Hard Floor	Rectangular	36" x 48"	Each	102.00
7 ESR-143012	Hard Floor	Lipped	45" x 53"	Each	117.28
8 ESR-143022	Hard Floor	Rectangular	46" x 60"	Each	135.24

## C - G CHAIR MATS

Protect floors from wear & tear as well as reduce fatigue by rolling easier with a clear EverLife® chair mat, the first chair mat assortment certified for low product emissions. Phthalate and Cadmium free. Carpet mats feature the exclusive AnchorBar® chair mat system—easy to handle; no sharp points. Manufacturer's limited "No Crack Mat" warranty. GREENGUARD Certified; GREENGUARD Gold Certified.

## C EVERLIFE® INTENSIVE USE CHAIR MAT FOR HIGH TO EXTRA-HIGH PILE CARPET

High performance chair mat for intensive use such as multi-shift or Big & Tall. Protects high pile carpet up to 1" thick including padding. Crystal beveled edge.

ID No.	Surface	Style	Overall (W x L)	Unit	Price
9 ESR-124054	High Pile	Lipped	36" x 48"	Each	144.55
10 ESR-124154	High Pile	Lipped	45" x 53"	Each	157.23
11 ESR-124377	High Pile	Rectangular	46" x 60"	Each	221.89

## D EVERLIFE® ALL DAY SUPPORT CHAIR MAT FOR MEDIUM PILE CARPET

For carpets up to ¾" thick including padding. All day support for everyday office use. Crystal beveled edge.

ID No.	Surface	Style	Overall (W x L)	Unit	Price
12 ESR-122073	Medium Pile	Lipped	36" x 48"	Each	110.31
13 ESR-122173	Medium Pile	Lipped	45" x 53"	Each	120.44
14 ESR-122371	Medium Pile	Rectangular	46" x 60"	Each	169.91

## E EVERLIFE® MODERATE USE CHAIR MAT FOR LOW PILE CARPET

For use with low pile carpet such as loop/berber style up to ¾" thick including padding. Crystal beveled edge.

ID No.	Surface	Style	Overall (W x L)	Unit	Price
15 ESR-128073	Low Pile	Lipped	36" x 48"	Each	84.95
16 ESR-128173	Low Pile	Lipped	45" x 53"	Each	97.63
17 ESR-128371	Low Pile	Rectangular	46" x 60"	Each	125.52

## F EVERLIFE® LIGHT USE CHAIR MAT FOR FLAT PILE CARPET

Protects low pile or commercial carpets up to ¼" thick including padding. High-quality task chair mat is ideal for home and light office applications. Straight edge.

ID No.	Surface	Style	Overall (W x L)	Unit	Price
18 ESR-120023	Flat Pile	Lipped	36" x 48"	Each	74.81
19 ESR-120123	Flat Pile	Lipped	45" x 53"	Each	88.75
20 ESR-120321	Flat Pile	Rectangular	46" x 60"	Each	111.57

## G EVERLIFE® CHAIR MAT FOR HARD FLOORS

Engineered for high performance and a smooth effortless roll. Clear mat designed to preserve and protect the beauty of laminate, wood, tile and other hard flooring. Protects against wear and tear from chair casters. Straight edge. Manufacturer's limited one-year warranty.

ID No.	Surface	Style	Overall (W x L)	Unit	Price
21 ESR-131115	Hard Floor	Lipped	36" x 48"	Each	53.64
22 ESR-131823	Hard Floor	Lipped	45" x 53"	Each	95.10
23 ESR-131826	Hard Floor	Rectangular	46" x 60"	Each	107.77

Prices subject to change without notice.  
Visit our website for the latest pricing and product information.

# Seating Mats

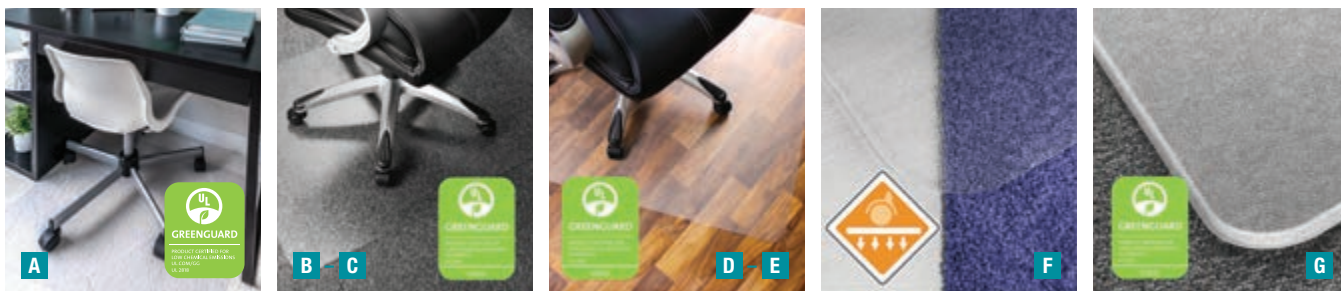

## A - E CLEARTEX® ULTIMAT® POLYCARBONATE CHAIR MATS

The ORIGINAL Polycarbonate Chair Mat provides the ultimate in quality, clarity and durability for home and office flooring. Twice the impact strength of vinyl to provide a perfect easy glide ergonomic surface for caster based chairs. High clarity polycarbonate allows the beauty of the floor to shine through and is the perfect gliding surface for chairs with casters. The rigid construction provides a perfect ergonomic easy glide surface for chairs with casters. Polycarbonate is extremely durable and does not curl, crack, dimple, discolor or smell under normal use. Manufactured using 25% renewable energy. 100% recyclable. Manufacturer's limited lifetime warranty. Greenguard Gold Certified.



### A CLEARTEX® ULTIMAT® POLYCARBONATE CHAIR MAT FOR HIGH PILE CARPETS

For high pile carpets.

ID No.	Surface	Style	Overall (W x L)	Unit	Price
1 FLR-EC118927ER	High Pile	Rectangular	35" x 47"	Each	<del>130.00</del>
2 FLR-ER1115227ER	High Pile over 1/2"	Rectangular	60" x 48"	Each	<del>202.80</del>

### B CLEARTEX® ULTIMAT® XXL POLYCARBONATE FLOOR PROTECTION MAT FOR ALL PILE CARPETS

All the attributes of the Ultimatt® polycarbonate range in extra-large sizes. High clarity, ultra-durable, highly rigid polycarbonate provides twice the impact strength of vinyl.

ID No.	Color	W x L	Qty.	Unit	Price
3 FLR-1115015023ER	Clear	60" x 60"	1	Carton	<del>249.59</del>
4 FLR-1115020023ER	Clear	59" x 79"	1	Carton	<del>311.99</del>

### C CLEARTEX® ULTIMAT® POLYCARBONATE CHAIR MAT FOR LOW/MEDIUM PILE CARPETS

For low/medium pile carpets up to 1/2".

ID No.	Surface	Style	Overall (W x L)	Unit	Price
5 FLR-EC118923ER	Low/Medium Pile Carpets up to 1/2"	Rectangular	35" x 47"	Each	<del>98.79</del>
6 FLR-ER1113423ER	Low/Medium Pile	Rectangular	48" x 53"	Each	<del>145.59</del>
7 FLR-ER1115223ER	Low/Medium Pile	Rectangular	48" x 60"	Each	<del>161.20</del>
8 FLR-ER1120023ER	Low/Medium Pile	Rectangular	48" x 79"	Each	<del>239.19</del>

### D CLEARTEX® ULTIMAT® POLYCARBONATE CHAIR MAT FOR HARD FLOORS

Safe for use on varnished or lacquered wood floors.

ID No.	Surface	Style	Overall (W x L)	Unit	Price
9 FLR-EC128919ER	Hard Floor	Rectangular	35" x 47"	Each	<del>88.39</del>
10 FLR-ER1215219ER	Hard Floor	Rectangular	48" x 60"	Each	<del>140.00</del>
11 FLR-ER1213419ER	Hard Floor	Rectangular	48" x 53"	Each	<del>130.00</del>

### E CLEARTEX® ULTIMAT® XXL POLYCARBONATE CHAIR MAT FOR HARD FLOORS

Safe for use on varnished or lacquered wood floors. Contains 25% total recycled content.

ID No.	Surface	Style	Overall (W x L)	Unit	Price
12 FLR-1215015019ER	Hard Floor	Square	60" x 60"	Each	<del>192.40</del>
13 FLR-1215020019ER	Hard Floor	Rectangular	60" x 79"	Each	<del>248.56</del>

### F CLEARTEX® UNOMAT ANTI-SLIP POLYCARBONATE CHAIR MAT FOR HARD FLOORS & FLAT PILE CARPETS

Original Floortex polycarbonate chair mat with anti-slip coating. Highly durable with twice the impact strength of vinyl. Prevents sliding for added stability on polished floors. Will not affect varnished or lacquered wooden floors. Suitable for all hard floors including laminates, parquet, tiles and smooth stone as well as very low, flat pile carpets. Contains 25% total recycled content.

ID No.	Surface	Style	Overall (W x L)	Unit	Price
14 FLR-EC128920ERA	Hard Floor	Rectangular	35" x 47"	Each	<del>98.80</del>
15 FLR-EC1215020ERA	Hard Floor	Rectangular	60" x 48"	Each	<del>155.95</del>

### G CLEARTEX® MEGAMAT™ HEAVY-DUTY POLYCARBONATE MATS FOR HARD FLOORS & ALL PILE CARPETS

The ultimate chair mat for the heavier user. Tested to 500 lbs. Ideal for use with Big & Tall chairs. Extremely durable polycarbonate will not crack, curl, cup, discolor or smell and is virtually unbreakable in normal use. Easy glide ergonomic surface. Clear construction allows the beauty of flooring to shine through. 100% recyclable and produced using 25% renewable energy. GREENGUARD Gold Certified.

ID No.	Surface	Style	Overall (W x L)	Unit	Price
16 FLR-ECM121345ER	All Pile Carpets/Hard Floors	Rectangular	46" x 53"	Each	<del>395.19</del>
17 FLR-ECM121525ER	All Pile Carpets/Hard Floors	Rectangular	46" x 60"	Each	<del>467.99</del>



## A CLIMATE CONTROL FOOTREST

Versatile unit works as a footrest or provides free-standing climate control. Features three temperature settings: cool fan, low heat and high heat. Adjustable footrest elevates your feet to relieve lower back pressure and improve posture. Two height settings (5½" and 6½"). Eight-hour auto-off feature. Economical unit runs on only 250 watts/2.1 amps.

ID No.	W × D × H	Color	Unit	Price
1 FEL-8030901 *	16½" × 10" × 5½" and 6½"	Black	Each	442.79

\* ETL Approved.

## B ENERGIZER™ FOOT SUPPORT

Innovating rubber surface with diverse massage textures targets pressure points. Elevates feet and legs to help relieve lower back pressure and improve posture. Free-floating platform allows for intuitive rocking motion to help promote lower leg movement. Scissor motion height adjustment provides three platform height settings (4", 5¼" and 6½") and up to 25° tilt. Manufacturer's limited one-year warranty.

ID No.	W × D × H	Color	Unit	Price
2 FEL-8068001	17½" × 13¼" × 4" to 6½"	Charcoal/Blue/Gray	Each	96.69

## C OFFICE SUITES™ ADJUSTABLE FOOTREST WITH MICROBAN® PROTECTION

Adjust for personal comfort using foot pressure—no bending or stooping required! Locking mechanism holds footrest in position or allows you to rock back and forth to encourage lower leg movement. Three different height settings (4¼", 4¾", or 5¾") and 30° forward or back tilt. Built-in Microban® antimicrobial protection helps keep product cleaner. Manufacturer's limited three-year warranty.

ID No.	W × D × H	Color	Unit	Price
3 FEL-8035001	17½" × 13¼" × 4¾" to 5¾"	Black/Silver	Each	86.89

## D ULTIMATE FOOT SUPPORT

Free-floating platform allows for rocking motion to help reduce fatigue. Surface massage bumps help relieve work-related stress. Three platform height settings (4", 5¼" and 6½") and up to 25 degree tilt. Elevates feet and legs to improve posture. Manufacturer's limited one-year warranty.

ID No.	W × D × H	Color	Unit	Price
4 FEL-8067001	17¾" × 13¼" × 4" to 6½"	Black/Gray	Each	72.59

## E STANDARD FOOTREST

Offers two-position height adjustment. Free-floating platform encourages lower leg movement to help reduce fatigue. Textured surface massages soles of feet. Manufacturer's one-year warranty. ♻️ ♻️

ID No.	W × D × H	Color	Unit	Price
5 FEL-48121 *	17¾" × 13¼" × 3¾"	Graphite	Each	29.99

\* Contains 89% post-consumer recycled content, 94% total recycled content.



## F PREMIUM ADJUSTABLE FOOTREST WITH ROLLERS

Rollers and surface bumps massage tired feet. Ergonomic design provides optimum comfort. Three level height adjustment, from 4" to 6½". Simple foot action makes tilt angle adjustments smooth and quiet. Manufacturer's limited one-year warranty.

ID No.	W × D × H	Color	Unit	Price
6 KTK-FR750	18" × 13" × 4" to 6½"	Black	Each	49.99



## G ERGO-COMFORT® ADJUSTABLE FOOTREST

Tilt angle slides easily to any position. Easy-glide design allows instant repositioning of feet and legs. Manufacturer's limited lifetime warranty.

ID No.	W × D × H	Color	Unit	Price
7 SAF-2106	18½" × 11½" × 8"	Black	Each	74.00
8 SAF-2105	18½" × 11½" × 5"	Black	Each	62.00

## H TASK MASTER® ADJUSTABLE FOOTREST

Fixed 8° angle helps relieve muscle strain. Adjusts to nine height positions with height range of 5½" to 15". Removable platform with textured anti-slip cover. Triangular steel base with black powder coated finish. ♻️

ID No.	W × D × H	Color	Unit	Price
9 SAF-5124	20" × 12" × 5½" to 15"	Black	Each	220.00

Prices subject to change without notice.  
Visit our website for the latest pricing and product information.

# Seating Footrests



## A RESTEASE™ ADJUSTABLE FOOTREST

Provides comfort and support for feet. Four angle adjustments from 6-25° and height adjusts from 3¼" to 5" for personal comfort preference. Supports feet to help reduce leg and back pressure, while integrated anti-slip rubber mat on platform keeps feet in desired position. Manufacturer's limited lifetime warranty.

ID No.	W × D × H	Color	Unit	Price
1 SAF-2120BL	15½" × 13¾" × 3¼" to 5"	Black/Silver	Each	56.00

## B FOOT ROCKER FOOTREST

Unique footrest features an incremental adjustment rocking action to promote circulation and muscle stimulation by encouraging leg movement. Smaller footprint takes less floor space under desk. Manufacturer's limited lifetime warranty.

ID No.	W × D × H	Color	Unit	Price
2 SAF-2122BL	17½" × 11½" × 3½"	Black	Each	64.00

## C REMEDEASE® FOOT CUSHION

Half-cylinder padded design allows infinite positioning for ultimate comfort. Hypoallergenic medical-grade foam distributes weight evenly. Nylon cover with nonslip tread is machine washable. Manufacturer's limited lifetime warranty.

ID No.	W × D × H	Color	Unit	Price
3 SAF-92311	17½" × 11½" × 6¼"	Black	Each	52.00

## Kensington

### D SOLEMATE™ COMFORT FOOTREST WITH SMARTFIT® SYSTEM

Luxurious memory foam soothes tired feet and eliminates stress on pressure points. With a flick-of-the-foot operated lock, the angle can be adjusted for all-day back and leg comfort. Height adjusts from 3½" to 5" to match your individual SmartFit® comfort color. Manufacturer's limited one-year warranty.

ID No.	W × D × H	Color	Unit	Price
4 KMW-56144	21½" × 14" × 3½" to 5"	Gray/Black	Each	97.97

### E SOLEMATE™ PLUS ADJUSTABLE FOOTREST WITH SMARTFIT® SYSTEM

Reduce muscle strain and fatigue by supporting your legs at an optimum angle. Height adjusts from 3.5" to 5" to match your individual comfort color. Angle adjusts 30 degrees and locks into place with a simple press of the foot. Features a non-skid surface. Manufacturer's two-year warranty.

ID No.	W × D × H	Color	Unit	Price
5 KMW-52789 ★	21.9" × 3.7" × 14.2"	Black	Each	84.26

★ TAA Compliant.



## F SOFT VCUSHIONED ANTI-FATIGUE ERGONOMIC FOOTREST

Provides precise ergonomic foot support for any user. Comfortable cushioned footrest helps reduce strain on the feet. Non-slip anti-fatigue cushioned mat. Clever foot adjustable tilt mechanism. Two tilt positions at 20 and 40 degrees as well as two height-adjustable positions. Non-slip, non-scratching floor pads keep your footrest in place on the floor. Manufacturer's limited five-year warranty. ✖

ID No.	W × D × H	Color	Unit	Price
6 ALE-FS112	14" × 19¾" × 3¼" to 7½"	Black	Each	59.00

## G RELAXING ADJUSTABLE FOOTREST

Provides precise ergonomic foot support for any user. Designed with roller surface bumps to both help massage tired feet and keep your foot from slipping. Three tilt positions from 20 to 70 degrees and three height-adjustable positions. Non-slip, non-scratching floor pads keep your footrest in place on the floor. Manufacturer's limited five-year warranty. ✖

ID No.	W × D × H	Color	Unit	Price
7 ALE-FS212	13¾" × 17¾" × 4½" to 6¾"	Black	Each	99.00

## H ERGO TILT FOOTREST

Tilting footrest for proper ergonomic alignment. Clever foot adjustable tilt mechanism rolls back and forth for your ideal angle from 0 to 20 degrees. Ribbed surface prevents feet from slipping. Non-slip, non-scratching floor pads keep your footrest in place on the floor. Manufacturer's limited five-year warranty. ✖

ID No.	W × D × H	Color	Unit	Price
8 ALE-FS312	13¾" × 17¾" × 3¾" to 5¾"	Black	Each	29.00



**Great Service**

We can help you with selection & solutions.



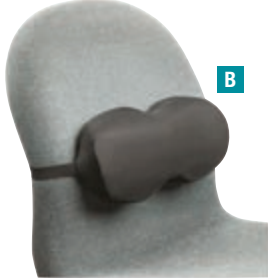

C-D Helps to maintain the spine's natural S-shaped curve



**A MESH BACKREST**

Ergonomically designed stretched mesh backrest supports the lower back. Contoured shape and curves to keep the back in alignment. Breathable mesh fabric keeps the back cool and supported. Adjustable elastic straps secure backrest in place. Great with office chairs, car seats, or in the home. Manufacturer's limited five-year warranty.

ID No.	W x D x H	Color	Qty.	Unit	Price
1 ALE-BR118	18 1/2" x 15 3/4" x 5 1/4"	Black	1	Each	<del>33.00</del>

**B LUMBAR SUPPORT MEMORY FOAM BACKREST**

Supports the lower back and spine to help minimize strain and fatigue. Unique shape and ergonomic memory foam reduces pressure points. Adjustable elastic strap for office chairs, car seats, or in the home. Smooth fabric cover is comfortable, durable, and removable for easy cleaning. Manufacturer's limited five-year warranty.

ID No.	W x D x H	Color	Qty.	Unit	Price
2 ALE-BR318	13.5" x 3.46" x 6.34"	Black	1	Each	<del>49.00</del>



**C LUMBAR SUPPORT MEMORY FOAM BACKREST**

Memory foam offers ultimate comfort and support. Updated style for additional comfort contours. Offers support along the spine, eliminating stress on pressure points and encouraging circulation. Smooth surface is durable and easily wipes clean. Adjustable strap holds cushion in place. Provides direct support to the small of the back. Manufacturer's limited lifetime warranty.

ID No.	W x D x H	Color	Qty.	Unit	Price
3 SAF-7154BL	14 1/2" x 3 3/4" x 6 3/4"	Black	1	Each	<del>46.00</del>



**D - E SOFTSPOT® TASK SUPPORT**

Supports the lower back and spine. Softly curved upper edges reduce stress on pressure points by gradually tapering away from user. Unique center channel averts pressure on spine. Helps to maintain the spine's natural S-shaped curve. Contoured Therasoft® material keeps its shape. Nonabrasive, antistatic, washable.

**D SOFTSPOT® LOW PROFILE BACKREST**

Provides maximum support for lower back. Elastic strap adjusts to fit any chair. Manufacturer's limited lifetime warranty.

ID No.	W x D x H	Color	Qty.	Unit	Price
4 SAF-7151BL	14" x 2 1/2" x 11"	Black	1	Each	<del>59.00</del>

**E SOFTSPOT® SEAT CUSHION**

Unique cut-away contours slope away from pressure points at the tailbone. Wedge shape helps promote proper seating posture. Manufacturer's limited lifetime warranty.

ID No.	W x D x H	Color	Qty.	Unit	Price
5 SAF-7152BL	15 1/2" x 10" x 3"	Black	1	Each	<del>82.00</del>



**F - G REMEDEASE™ BACKREST**

Ergonomic shape helps minimize back strain and fatigue. High-density foam retains its shape. Machine-washable 100% polyester cover. Elastic strap adjusts to fit any chair.

**F REMEDEASE® HIGH PROFILE BACKREST**

Deeply contoured backrest provides support and comfort. Manufacturer's limited lifetime warranty.

ID No.	W x D x H	Color	Qty.	Unit	Price
6 SAF-71491	12 3/4" x 4" x 13"	Black	1	Each	<del>53.00</del>

**G REMEDEASE® FULL HEIGHT BACKREST**

Low-profile design offers full back support. Manufacturer's limited lifetime warranty.

ID No.	W x D x H	Color	Qty.	Unit	Price
7 SAF-71301	14" x 3" x 19 1/2"	Black	1	Each	<del>65.00</del>

**H MESH BACKREST**

Unique design offers comfort and support while promoting good posture. Breathable mesh allows airflow for cool, comfortable use. Elastic strap secures backrest in place. Manufacturer's limited lifetime warranty.

ID No.	W x D x H	Color	Qty.	Unit	Price
8 SAF-7153BL	17 1/2" x 3" x 15"	Black	1	Each	<del>40.00</del>

Prices subject to change without notice. Visit our website for the latest pricing and product information.

# Seating Back Supports



## ADVANTUS

### A MEMORY FOAM MASSAGE LUMBAR CUSHION

Soft memory foam cradles the back in comfort. Invigorating massage motor for the lumbar and other back areas. Breathable mesh fabric. Use at home, office, or in automobiles. Requires 4 AA batteries (not included). Manufacturer's limited one-year warranty.

ID No.	W × D × H	Color	Qty.	Unit	Price
1 AVT-60-2804MH05	12¾" × 3¾" × 12"	Black	1	Each	52.20

## ALERA.

### B DELUXE BACK SUPPORT

Contoured back support for optimal spinal alignment. Curved polyurethane foam adjusts to your lower back with a convex spinal pressure point. Adjustable straps easily mount to any chair. Removable cover is machine washable. Manufacturer's limited five-year warranty.

ID No.	W × D × H	Color	Qty.	Unit	Price
2 ALE-BR210	15½" × 3" × 11"	Black	1	Each	45.00

### C COOLING GEL MEMORY FOAM BACKREST

Soft, resilient memory foam cushion is pressure sensitive to help relieve stress points. Smart gel-cooling layer helps provides longer lasting cooling by dissipating heat. Long-lasting, fade-resistant fabric cover. Washable. Manufacturer's limited five-year warranty.

ID No.	W × D × H	Color	Qty.	Unit	Price
--------	-----------	-------	------	------	-------

<b>Backrest</b> —Two adjustable straps to keep your backrest in place at the optimal lumbar position.					
3 ALE-CGC411	14.13" × 14.13" × 2.75"	Black	1	Each	60.00

### D COOLING GEL MEMORY FOAM SEAT CUSHION

Soft, resilient memory foam cushion is pressure sensitive to help relieve stress points. Smart gel-cooling layer helps provides longer lasting cooling by dissipating heat. Non-slip under-cushion cover keeps the cushion firmly in place on your chair. Long-lasting, fade-resistant fabric cover. Washable. Manufacturer's limited five-year warranty.

ID No.	W × D × H	Color	Qty.	Unit	Price
--------	-----------	-------	------	------	-------

<b>Seat Cushion</b> —Non-slip undercushion cover keeps the cushion firmly in place on your chair.					
4 ALE-CGC511	16.5" × 15.75" × 2.75"	Black	1	Each	66.00

## PROTECTION THAT LIVES ON MICROBAN®

## Fellowes

### E HEAT AND SOOTHE BACK SUPPORT

Personalize workspace comfort with temperature control and back support. Gel lumbar pack conforms to individual users for flexible back support. Gel pack heats up in microwave or chills in refrigerator. Slim profile with soft touch fabric. Adjustable strap with buckle fits most modern office chairs. Manufacturer's limited three-year warranty.

ID No.	W × D × H	Color	Qty.	Unit	Price
5 FEL-9190001	14½" × 3" × 13¾"	Black	1	Each	59.99

### F LUMBAR BACK SUPPORT

Low-profile design for maximum lumbar support. Works to support the lower back for comfort during extended periods of sitting. High-density foam promotes neutral posture while the adjustable strap holds the lumbar back support in place. Soft touch fabric cover. Manufacturer's limited one-year warranty.

ID No.	W × D × H	Color	Qty.	Unit	Price
6 FEL-9190701	12" × 3½" × 5¾"	Black	1	Each	36.99

### G I-SPIRE SERIES™ LUMBAR CUSHION

Supports your lower back for enhanced comfort while seated and helps reduce back tension. Adjustable strap with durable buckle holds cushion in place while the breathable mesh fabric enhances personal comfort. Look for coordinating I-Spire Series™ products from Fellowes®. Manufacturer's limited one-year warranty.

ID No.	W × D × H	Color	Qty.	Unit	Price
7 FEL-9311601	14" × 6" × 3"	Gray	1	Each	44.99

### H PROFESSIONAL SERIES BACK SUPPORT WITH MICROBAN® PROTECTION

Mid-spinal support with memory foam cushion promotes good posture. Lower lumbar support with three memory foam sections conforms comfortably to natural body curvatures. Microban® antimicrobial protection helps keep product cleaner. Innovative Tri-Tachment™ system eliminates the need for readjustment. Fits most office chairs. Manufacturer's limited lifetime warranty.

ID No.	W × D × H	Color	Qty.	Unit	Price
8 FEL-8037601	15" × 2" × 14½"	Black	1	Each	75.99

# Files

Conquer paperwork pileup with easy-access organization.



**Organization is everything** when it comes to streamlining your office and workflow. And despite all of the new technology, paper management is still one of the biggest challenges in every office. Tame the paper tiger with efficient filing that makes the most of your space. From practical backroom archives to sleek dual-purpose file/seating, we have what it takes to put paper in its place.

Shelf Files	166
Lateral Files	167-169
Fireproof/Safes	169-173
Vertical Files	174-175
Pedestal Files	176-177
Mobile	178-181
Storage Mobile & Multi-Media	182



## Snap-Together Shelving Units

Save 50% of the floor space used by conventional files.

- For highly active files and records.
- Heavy-duty rolled steel construction in a sand finish.
- 200- to 300-lb load capacity per shelf with weight evenly distributed.
- Includes adjustable 12" deep shelves, shelf supports and five file dividers per shelf.
- Manufacturer's limited one-year warranty.
- Contains 19% post-consumer recycled content, 25% total recycled content.
- Meets or Exceeds ANSI/BIFMA Standards; SCS Indoor Advantage Gold Certified. ♻️ ♻️ ♻️ ♻️

ID No.	Color	Size	Qty.	Unit	Price
--------	-------	------	------	------	-------

### A SNAP-TOGETHER CLOSED STARTER UNIT

Provides a single freestanding unit. Use with Add-On Units for a complete wall system. Units snap together without tools or fasteners. All shelves are adjustable. Order one Starter Set and any number of matching height Add-On Units. Two "L" uprights for the frame.

1	TNN-12884PCSD	Sand	48" × 12" × 88"	1	Each	<del>594.00</del>
2	TNN-12764PCSD	Sand	48" × 12" × 76"	1	Each	<del>519.00</del>
3	TNN-1288PCSD	Sand	36" × 12" × 88"	1	Each	<del>485.00</del>
4	TNN-1276PCSD	Sand	36" × 12" × 76"	1	Each	<del>425.00</del>

### B SNAP-TOGETHER CLOSED ADD-ON UNIT

"T" shaped upright attaches to Starter Set to join units. Use with Starter Sets for a complete wall system.

5	TNN-12884ACSD	Sand	48" × 12" × 88"	1	Each	<del>541.00</del>
6	TNN-12764ACSD	Sand	48" × 12" × 76"	1	Each	<del>459.00</del>
7	TNN-1288ACSD	Sand	36" × 12" × 88"	1	Each	<del>452.00</del>
8	TNN-1276ACSD	Sand	36" × 12" × 76"	1	Each	<del>381.00</del>

### C FIXED SHELF LATERAL FILE

Keep a maximum amount of files in a minimum amount of space. You'll save valuable floor space and enjoy easy access to your files. Perfect for color-coded filing systems, books, manuals and more. Manufacturer's one-year warranty. Contains 40% post-consumer recycled content, 85% total recycled content. SCS Indoor Advantage Gold Certified. ♻️ ♻️ ♻️ ♻️

ID No.	Description	Color	W × D × H	Shpg. Wt.	Unit	Price
--------	-------------	-------	-----------	-----------	------	-------

9	TNN-FS351LLGY	5 Drawers	Light Gray	36" × 16½" × 63½"	180 lbs.	Each <del>1,436.00</del>
10	TNN-FS361LLGY	6 Drawers	Light Gray	36" × 16½" × 75¼"	218 lbs.	Each <del>1,645.00</del>
11	TNN-FS371LLGY	7 Drawers	Light Gray	36" × 16½" × 87"	242 lbs.	Each <del>1,821.00</del>

### OPEN SHELVES—Instant visual access to materials.

12	TNN-FS350LGY	5 Drawers	Light Gray	36" × 16½" × 63½"	124 lbs.	Each <del>818.00</del>
13	TNN-FS360LGY	6 Drawers	Light Gray	36" × 16½" × 75¼"	150 lbs.	Each <del>891.00</del>
14	TNN-FS370LGY	7 Drawers	Light Gray	36" × 16½" × 87"	175 lbs.	Each <del>1,000.00</del>





**HON**

## Brigade® 700 Series Lateral Files

Heavy-duty steel ball-bearing drawer suspensions operate easily and quietly.

- Drawers include side-to-side hangrails for letter or legal size filing and magnetic label holder.
- Mechanical interlock allows only one drawer to be open at a time to prevent tipping.
- Counterweight included, where applicable, to meet ANSI/BIFMA requirements.
- Four adjustable leveling glides help compensate for uneven flooring.
- HON® "One Key" interchangeable core removable locks.
- Backed by the HON Full Lifetime Warranty.
- Contains 12% pre-consumer recycled content, 24% post-consumer recycled content.
- Level 2 Certified; Meets or Exceeds ANSI/BIFMA Standards; SCS Indoor Advantage Gold Certified.



### HON Lateral File Accessories

#### SINGLE CROSS RAILS FOR 30" AND 36" LATERAL FILES

Create front-to-back filing. For 30" laterals—makes two rows of letter-size filing for two drawers. For 36" laterals—makes two rows of letter- or legal-size filing for two drawers. Backed by the HON Full Lifetime Warranty.

ID No.	Color	Qty.	Unit	Price
41 HON-919491	Gray	4	Pack	69.00

#### DOUBLE CROSS RAILS FOR 42" WIDE LATERAL FILES

Makes three rows of front-to-back letter size filing. Order one pack per drawer/shelf. Two rails per pack. Backed by the HON Full Lifetime Warranty.

ID No.	Color	Qty.	Unit	Price
42 HON-919492	Gray	2	Pack	69.00

#### REMOVABLE LOCK CORE REPLACEMENT KIT

For one-key convenience in a work area. Order the standard product (shipped with factory installed locks using random numbered cores). Order the appropriate quantity of replacement cores for each workstation or keyed area. Includes one core, two keys, core-removal tool adapter and instructions.



ID No.	Color	Qty.	Unit	Price
43 HON-F23CX	Brushed Chrome	1	Each	42.00

Description	ID	Black	Charcoal	Light Gray	Putty	W x D x H	Shpg. Wt.	Unit	Price
<b>A LATERAL FILES</b> —Durable laminate top with painted apron and chrome legs.									
<b>42" Wide Files – 5 Drawers</b>	1	HON-795LP	11 HON-795LS	21 HON-795LQ	31 HON-795LQ	42" x 18" x 64¼"	244 lbs.	Each	2,302.00
<b>4 Drawers</b>	2	HON-794LP	12 HON-794LS	22 HON-794LQ	32 HON-794LL	42" x 18" x 52½"	232 lbs.	Each	1,795.00
<b>3 Drawers</b>	3	HON-793LP	13 HON-793LS	23 HON-793LQ	33 HON-793LL	42" x 18" x 39½"	190 lbs.	Each	1,422.00
<b>2 Drawers</b>	4	HON-792LP	14 HON-792LS	24 HON-792LQ	34 HON-792LL	42" x 18" x 28"	141 lbs.	Each	999.00
<b>36" Wide Files – 5 Drawers</b>	5	HON-785LP	15 HON-785LS	25 HON-785LQ	35 HON-785LL	36" x 18" x 64¼"	215 lbs.	Each	1,901.00
<b>4 Drawers</b>	6	HON-784LP	16 HON-784LS	26 HON-784LQ	36 HON-784LL	36" x 18" x 52½"	217 lbs.	Each	1,512.00
<b>3 Drawers</b>	7	HON-783LP	17 HON-783LS	27 HON-783LQ	37 HON-783LL	36" x 18" x 39½"	175 lbs.	Each	1,226.00
<b>2 Drawers</b>	8	HON-782LP	18 HON-782LS	28 HON-782LQ	38 HON-782LL	36" x 18" x 28"	131 lbs.	Each	866.00
<b>B LATERAL FILES WITH STORAGE CABINET</b> —Hinged doors conceal 36¼" h storage space with two adjustable shelves. Bottom shelves hold two rows of three-ring binders. Keyed alike locks secure doors and lateral file drawers independently. Two lateral file drawers with steel bearing suspension for letter/legal size filing.									
<b>42" Wide Files – 2 Drawers</b>	9	HON-795LSP	19 HON-795LSS	29 HON-795LSQ	39 HON-795LSL	42" x 18" x 64¼"	230 lbs.	Each	1,789.00
<b>36" Wide Files – 2 Drawers</b>	10	HON-785LSP	20 HON-785LSS	30 HON-785LSQ	40 HON-785LSL	36" x 18" x 64¼"	211 lbs.	Each	1,565.00



\* HON-795LP, HON-795LS, HON-795LQ, HON-795LL, HON-785LP, HON-785LS, HON-785LQ, HON-785LL—Top drawer is a roll-out shelf with receding door. Posting shelf above the third drawer.

Prices subject to change without notice. Visit our website for the latest pricing and product information.

## HON.

### Brigade® 600 Series Lateral Files

Exceptional construction and remarkably smooth drawer operation make the Brigade® 600 Series your top choice for lateral files.

- Mechanical interlock allows only one drawer to be open at a time to prevent tipping.
- Four adjustable leveling glides help compensate for uneven flooring.
- Drawers include side-to-side hangrails for letter or legal size filing, anodized aluminum recessed drawer pulls and magnetic label holder.
- Counterweight included, where applicable, to meet ANSI/BIFMA stability requirements.
- Lock secures both sides of drawer.
- HON "One Key" interchangeable core removable locks.
- Backed by the HON Full Lifetime Warranty.
- Contains 12% pre-consumer recycled content, 24% post-consumer recycled content.
- Level 2 Certified; Meets or Exceeds ANSI/BIFMA Standards; SCS Indoor Advantage Gold Certified.   



Five-high models feature a posting shelf and a roll-out shelf in the top drawer.





Light Gray (Q)

Black (P)

Charcoal (S)



Requires additional lead time and cannot be returned.

Description	ID Black	ID Charcoal	ID Light Gray	ID Putty	W x D x H	Shpg. Wt.	Unit	Price
<b>42" WIDE FILES</b>								
<b>5 Drawers</b>	1 HON-695LP *	13 HON-695LS *	25 HON-695LQ *	37 HON-695LL *	42" x 18" x 64 1/4"	244 lbs.	Each	<del>2,128.00</del>
<b>4 Drawers</b>	2 HON-694LP	14 HON-694LS	26 HON-694LQ	38 HON-694LL	42" x 18" x 52 1/2"	232 lbs.	Each	<del>1,610.00</del>
<b>3 Drawers</b>	3 HON-693LP	15 HON-693LS	27 HON-693LQ	39 HON-693LL	42" x 18" x 39 1/2"	190 lbs.	Each	<del>1,285.00</del>
<b>2 Drawers</b>	4 HON-692LP	16 HON-692LS	28 HON-692LQ	40 HON-692LL	42" x 18" x 28"	141 lbs.	Each	<del>924.00</del>
<b>36" WIDE FILES</b>								
<b>5 Drawers</b>	5 HON-685LP *	17 HON-685LS *	29 HON-685LQ *	41 HON-685LL *	36" x 18" x 64 1/4"	215 lbs.	Each	<del>1,764.00</del>
<b>4 Drawers</b>	6 HON-684LP	18 HON-684LS	30 HON-684LQ	42 HON-684LL	36" x 18" x 52 1/2"	217 lbs.	Each	<del>1,350.00</del>
<b>3 Drawers</b>	7 HON-683LP	19 HON-683LS	31 HON-683LQ	43 HON-683LL	36" x 18" x 39 1/2"	175 lbs.	Each	<del>1,094.00</del>
<b>2 Drawers</b>	8 HON-682LP	20 HON-682LS	32 HON-682LQ	44 HON-682LL	36" x 18" x 28"	131 lbs.	Each	<del>783.00</del>
<b>30" WIDE FILES</b>								
<b>5 Drawers</b>	9 HON-675LP *	21 HON-675LS *	33 HON-675LQ *	45 HON-675LL *	30" x 18" x 64 1/4"	199 lbs.  	Each	<del>1,650.00</del>
<b>4 Drawers</b>	10 HON-674LP	22 HON-674LS	34 HON-674LQ	46 HON-674LL	30" x 18" x 52 1/2"	197 lbs.  	Each	<del>1,201.00</del>
<b>3 Drawers</b>	11 HON-673LP	23 HON-673LS	35 HON-673LQ	47 HON-673LL	30" x 18" x 39 1/2"	158 lbs.	Each	<del>1,000.00</del>
<b>2 Drawers</b>	12 HON-672LP	24 HON-672LS	36 HON-672LQ	48 HON-672LL	30" x 18" x 28"	121 lbs.	Each	<del>720.00</del>

\* HON-695LP, HON-695LS, HON-695LQ, HON-695LL, HON-685LP, HON-685LS, HON-685LQ, HON-685LL, HON-675LP, HON-675LS, HON-675LQ, HON-675LL—Top drawer is a roll-out shelf with receding door. Posting shelf above the third drawer.



Putty (L)



Black (P)



Putty (L)

Black (P)

## HON.

### 400 Series Lateral Files

An affordable lateral file for light use.

- Mechanical interlock allows only one drawer to open at a time to prevent tipping.
- Steel ball-bearing drawer suspensions operate easily and quietly.
- Two adjustable leveling glides.
- Side-to-side rails hold letter/legal size files.
- Locking drawers.
- Counterweight included to meet ANSI/BIFMA stability requirements.
- Backed by the HON Limited Five-Year Warranty. 

ID	Description	No.	Color	W x D x H	Shpg. Wt.	Unit	Price
<b>36" WIDE FILES</b>							
49	<b>4 Drawers</b>	BSX-484LP	Black	36" x 18" x 52 1/2"	217 lbs.	Each	<del>1,035.00</del>
50	<b>4 Drawers</b>	BSX-484LL	Putty	36" x 18" x 52 1/2"	217 lbs.	Each	<del>1,035.00</del>
51	<b>2 Drawers</b>	BSX-482LP	Black	36" x 18" x 28"	131 lbs.	Each	<del>642.00</del>
52	<b>2 Drawers</b>	BSX-482LL	Putty	36" x 18" x 28"	131 lbs.	Each	<del>642.00</del>
<b>30" WIDE FILES</b>							
53	<b>4 Drawers</b>	BSX-434LP	Black	30" x 18" x 52 1/2"	197 lbs.	Each	<del>905.00</del>
54	<b>4 Drawers</b>	BSX-434LL	Putty	30" x 18" x 52 1/2"	197 lbs.	Each	<del>905.00</del>
55	<b>2 Drawers</b>	BSX-432LP	Black	30" x 18" x 28"	121 lbs.	Each	<del>615.00</del>
56	<b>2 Drawers</b>	BSX-432LL	Putty	30" x 18" x 28"	121 lbs.	Each	<del>615.00</del>



## Lateral File

Drawers with side-to-side hang rails to accommodate letter/legal hanging files.

- Full drawer extension on steel ball bearing telescoping slide suspension.
- Stylish full-width radius edge recessed pulls.
- Anti-tipping interlock system allows only one drawer to open at a time.
- Single key core removable lock with two keys.
- Manufacturer's limited five-year warranty.
- Contains 24% post-consumer recycled content, 36% total recycled content.
- Level 2 Certified; Meets or Exceeds ANSI/BIFMA Standards and ISTA Performance Standards; SCS Indoor Advantage Gold Certified.

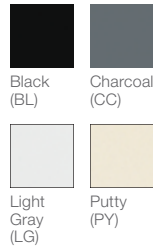

Description	ID	Black	Charcoal	Light Gray	Putty	W x D x H	Shpg. Wt.	Unit	Price
<b>42" WIDE FILES</b>									
5 Drawers	1	ALE-LF4267BL	12 ALE-LF4267CC	23 ALE-LF4267LG	34 ALE-LF4267PY	42" x 18" x 64 1/4"	244 lbs.	Each	<del>1,649.00</del>
4 Drawers	2	ALE-LF4254BL	13 ALE-LF4254CC	24 ALE-LF4254LG	35 ALE-LF4254PY	42" x 18" x 52 1/2"	232 lbs.	Each	<del>1,319.00</del>
3 Drawers	3	ALE-LF4241BL	14 ALE-LF4241CC	25 ALE-LF4241LG	36 ALE-LF4241PY	42" x 18" x 39 1/2"	190 lbs.	Each	<del>1,089.00</del>
2 Drawers	4	ALE-LF4229BL	15 ALE-LF4229CC	26 ALE-LF4229LG	37 ALE-LF4229PY	42" x 18" x 28"	141 lbs.	Each	<del>849.00</del>
<b>36" WIDE FILES</b>									
5 Drawers	5	ALE-LF3667BL	16 ALE-LF3667CC	27 ALE-LF3667LG	38 ALE-LF3667PY	36" x 18" x 64 1/4"	215 lbs.	Each	<del>1,531.00</del>
4 Drawers	6	ALE-LF3654BL	17 ALE-LF3654CC	28 ALE-LF3654LG	39 ALE-LF3654PY	36" x 18" x 52 1/2"	217 lbs.	Each	<del>1,254.00</del>
3 Drawers	7	ALE-LF3641BL	18 ALE-LF3641CC	29 ALE-LF3641LG	40 ALE-LF3641PY	36" x 18" x 39 1/2"	175 lbs.	Each	<del>1,009.00</del>
2 Drawers	8	ALE-LF3629BL	19 ALE-LF3629CC	30 ALE-LF3629LG	41 ALE-LF3629PY	36" x 18" x 28"	131 lbs.	Each	<del>779.00</del>
<b>30" WIDE FILES</b>									
4 Drawers	9	ALE-LF3054BL	20 ALE-LF3054CC	31 ALE-LF3054LG	42 ALE-LF3054PY	30" x 18" x 52 1/2"	197 lbs.	Each	<del>1,089.00</del>
3 Drawers	10	ALE-LF3041BL	21 ALE-LF3041CC	32 ALE-LF3041LG	43 ALE-LF3041PY	30" x 18" x 39 1/2"	158 lbs.	Each	<del>832.00</del>
2 Drawers	11	ALE-LF3029BL	22 ALE-LF3029CC	33 ALE-LF3029LG	44 ALE-LF3029PY	30" x 18" x 28"	121 lbs.	Each	<del>604.00</del>

## Additional Items

### B TWO ROW HANGRAILS (NOT SHOWN)

Creates two rows of front-to-back letter/legal size filing in one drawer of a 30" or 36" wide drawer. Manufacturer's limited five-year warranty.

ID No.	Qty.	Unit	Price
45 ALE-LF3036	4	Pack	<del>70.00</del>

### C THREE ROW HANGRAILS (NOT SHOWN)

Creates three rows of front-to-back letter size filing in 42" files. Two rails per pack; order one pack per drawer/shelf. Manufacturer's limited five-year warranty.

ID No.	Qty.	Unit	Price
50 ALE-LF42	2	Pack	<del>92.00</del>



## Insulated File Cabinets

Protect valuable documents against fire, impact and water damage.

- During testing, files are subjected to temperatures of 1,700°F for one or two hours and impact-rated to simulate a collapsing ceiling or wall.
- High security key lock to resist picking and drilling.
- Water-resistant; designed to prevent water damage resulting from sprinklers and fire hoses.
- Manufacturer's lifetime warranty on parts; free after-fire replacement on file cabinet.

### D INSULATED LATERAL FILE

UL one-hour fire and impact tested. Hang letter- or legal-size folders.

ID	Description	No.	Color	W x D x H	Shpg. Wt.	Unit	Price
<b>37 1/2" Wide Files</b>							
46	4 Drawers	FIR-43822CPA	★ Parchment	37 1/2" x 22 1/4" x 52 3/4"	907 lbs.	Each	<del>7,470.00</del>
47	2 Drawers	FIR-23822CPA	★ Parchment	37 1/2" x 22 1/4" x 27 3/4"	532 lbs.	Each	<del>5,133.00</del>
<b>31 1/2" Wide Files</b>							
48	4 Drawers	FIR-43122CPA	★ Parchment	31 1/2" x 22 1/4" x 52 3/4"	794 lbs.	Each	<del>6,266.00</del>

★ UL Class 350-One-Hour with Impact Resistance; UL Listed Security Lock.

### E INSULATED STORAGE CABINET

Designed to protect oversized binders, documents, end-tab filing and other valuable items. Equipped with a High Security Medeco Key Lock—ensuring resistance to picking and drilling. Scratch-resistant finish.

ID No.	Color	W x D x H	Shpg. Wt.	Unit	Price	
<b>72" High</b> —Three adjustable shelves.						
49	FIR-CF7236-D	★ Parchment	36" x 19 1/4" x 72"	892 lbs.	Each	<del>6,001.00</del>

★ UL Class 350 One-Hour Rating.



A



## FireKing Safety Features



**UL 1 hr fire rated**  
Internal temperature will not exceed 350° for 1 hour



**water resistant**  
All FireKing files are designed to prevent water damage resulting from sprinklers and fire hoses



**UL 30ft impact rated**  
Designed to withstand a 30 foot drop



Black (BL)



Parchment (PA)

Parchment (PA)

## Special FEATURES

Powder-coated finish

Advanced formula insulation with enhanced thermal properties

Oven-dried insulation reinforced with welded wire

Insulation between all drawers

Extra insulation on drawer heads



## Insulated File Cabinets

Protect valuable documents against fire, impact and water damage.

- During testing, files are subjected to temperatures of 1,700°F for one or two hours and impact-rated to simulate a collapsing ceiling or wall.
- Insulation between drawers makes each drawer a separate, fireproof unit.
- Water-resistant; designed to prevent water damage resulting from sprinklers and fire hoses.
- Manufacturer's limited ten-year warranty; free after fire replacement on file cabinet.

### A PATRIOT BY FIREKING INSULATED FIRE FILE

Value-priced fire protection for all your important files. Insulated steel construction with a durable powder coated finish. UL one-hour fire and impact tested. Locking drawers operate on full-extension ball bearing slides.

ID	Description	No.	Color	W × D × H	Shpg. Wt.	Unit	Price
<b>4 Drawers</b>							
1	Legal	FIR-4P2131-CBL	Black	20¾" × 31¾" × 52¾"	664 lbs.	Each	<del>3,250.00</del>
2	Legal	FIR-4P2131-CPA	Parchment	20¾" × 31¾" × 52¾"	664 lbs.	Each	<del>3,250.00</del>
3	Letter	FIR-4P1831-CBL	Black	17¾" × 31¾" × 52¾"	603 lbs.	Each	<del>3,079.00</del>
4	Letter	FIR-4P1831-CPA	Parchment	17¾" × 31¾" × 52¾"	603 lbs.	Each	<del>3,079.00</del>
<b>4 Drawers</b>							
5	Legal; Letter	FIR-4P1825-CBL	Black	17¾" × 25" × 52¾"	508 lbs.	Each	<del>2,679.00</del>
6	Legal; Letter	FIR-4P1825-CPA	Parchment	17¾" × 25" × 52¾"	508 lbs.	Each	<del>2,679.00</del>
<b>2 Drawers</b>							
7	Legal; Letter	FIR-2P1825-CBL	Black	17¾" × 25" × 27¾"	287 lbs.	Each	<del>1,731.00</del>
8	Legal; Letter	FIR-2P1825-CPA	Parchment	17¾" × 25" × 27¾"	287 lbs.	Each	<del>1,731.00</del>

### B FOUR-DRAWER INSULATED VERTICAL FILE

UL Class 350-One-Hour with Impact Resistance; UL Listed Security Lock.

ID	No.	Color	W × D × H	Shpg. Wt.	Unit	Price
<b>Legal Size</b> —26" legal-size folder filing capacity.						
9	FIR-42131CBL	Black	20½" × 31¾" × 52¾"	664 lbs.	Each	<del>4,054.00</del>
	FIR-42131CPA	Parchment	20½" × 31¾" × 52¾"	664 lbs.	Each	<del>4,054.00</del>
<b>Legal Size</b> —19¾" legal-size folder filing capacity.						
11	FIR-42125CBL	Black	20½" × 25" × 52¾"	551 lbs.	Each	<del>4,050.00</del>
12	FIR-42125CPA	Parchment	20½" × 25" × 52¾"	551 lbs.	Each	<del>4,050.00</del>
<b>Letter Size</b> —Letter-size filing capacity.						
13	FIR-41831CBL	Black	17¾" × 31¾" × 52¾"	603 lbs.	Each	<del>4,025.00</del>
14	FIR-41831CPA	Parchment	17¾" × 31¾" × 52¾"	603 lbs.	Each	<del>4,025.00</del>
15	FIR-41825CBL	Black	17¾" × 25" × 52¾"	508 lbs.	Each	<del>3,003.00</del>
16	FIR-41825CPA	Parchment	17¾" × 25" × 52¾"	508 lbs.	Each	<del>3,003.00</del>

**"Free After Fire Replacement"**

B



Black (BL)

C



Parchment (PA)

### C COMPACT TURTLE® INSULATED VERTICAL FILE

Cleverly designed to conceal a 1.3 cubic foot safe with ¾" solid steel door behind a false top drawer panel. UL Class 350-One-Hour with Impact Resistance. For letter- and legal-size documents.

ID	Description	No.	Color	W × D × H	Shpg. Wt.	Unit	Price
<b>4 Drawers</b>							
17	Legal; Letter	FIR-4R1822CPA	Parchment	17¾" × 22½" × 52¾"	435 lbs.	Each	<del>2,349.00</del>
<b>2 Drawers</b>							
18	Legal; Letter	FIR-2R1822CPA	Parchment	17¾" × 22½" × 27¾"	251 lbs.	Each	<del>1,359.00</del>





**A – C WATER AND FIREPROOF SAFES**

Safeguard your belongings from the most unexpected perils. Large 1-inch bolts – 60% bigger than traditional safes. Pry resistant hinge bar helps provide additional protection. Advanced fire protection – UL Classified for 1 hour Fire Endurance to protect documents and valuables. ETL Verified 15 foot/4.5 meter drop test to ensure contents remain intact and locked upon impact. ETL Verified for 1 hour fire protection of CDs, DVDs, Memory Sticks and USB Drives. ETL Verified water-resistance for 24 hours (except on model # SFW123ES).

**A SAFE WITH FINGERPRINT AND DIGITAL KEYPAD ACCESS WITH BACKUP KEY**

ID No.	Capacity	Exterior (W x D x H)	Shpg. Wt.	Unit	Price
File organizer, adjustable shelf, bolt-down hardware, and interior LED light. Interior: 14.8" x 11.9" x 19.6".					
1	SEN-SFW205BPC	2 cu ft	18.6" x 19.3" x 23.8"	125 lbs.	Each <del>720.67</del>
Adjustable shelf, bolt-down hardware, and interior LED light. Interior: 12.6" x 11.9" x 13.8".					
2	SEN-SFW123BSC	1.23 cu ft	16.3" x 19.3" x 17.8"	86 lbs.	Each <del>505.19</del>

**B SAFE WITH DIGITAL KEYPAD ACCESS**

ID No.	Capacity	Exterior (W x D x H)	Shpg. Wt.	Unit	Price
Two adjustable trays and bolt-down hardware. Interior: 14 <sup>7</sup> / <sub>8</sub> " x 12" x 19 <sup>1</sup> / <sub>2</sub> ".					
3	SEN-SFW205EVB	2 cu. ft.	18 <sup>3</sup> / <sub>8</sub> " x 19 <sup>1</sup> / <sub>8</sub> " x 23 <sup>3</sup> / <sub>8</sub> "	138 lbs.	Each <del>463.95</del>
Adjustable shelf. Interior: 12 <sup>5</sup> / <sub>8</sub> " x 11 <sup>1</sup> / <sub>8</sub> " x 13 <sup>1</sup> / <sub>8</sub> ".					
4	SEN-SFW123ES *	1.23 cu. ft.	16 <sup>1</sup> / <sub>8</sub> " x 19 <sup>1</sup> / <sub>8</sub> " x 17 <sup>1</sup> / <sub>8</sub> "	95 lbs.	Each <del>298.99</del>
Adjustable tray, bolt-down hardware, and interior LED light. Interior: 12 <sup>9</sup> / <sub>16</sub> " x 11 <sup>1</sup> / <sub>2</sub> " x 9 <sup>5</sup> / <sub>8</sub> ".					
5	SEN-SFW082FTC *	0.8 cu. ft.	16 <sup>1</sup> / <sub>16</sub> " x 19 <sup>1</sup> / <sub>16</sub> " x 13 <sup>3</sup> / <sub>32</sub> "	85 lbs.	Each <del>283.53</del>

\* SEN-SFW123ES, SEN-SFW082FTC—Contains 10% post consumer recycled content in the steel.

**C SAFE WITH COMBINATION ACCESS**

ID No.	Capacity	Exterior (W x D x H)	Shpg. Wt.	Unit	Price
Adjustable 5 inch deep organizer and tray, bolt down hardware. Interior: 14.8" x 11.9" x 19.6".					
6	SEN-SFW205CWB	2 cu ft	18.6" x 19.3" x 23.8"	125 lbs.	Each <del>422.19</del>
Adjustable shelf and bolt-down hardware. Interior: 12 <sup>5</sup> / <sub>8</sub> " x 11 <sup>1</sup> / <sub>8</sub> " x 13 <sup>7</sup> / <sub>8</sub> ".					
7	SEN-SFW123CSB *	1.23 cu. ft.	16 <sup>1</sup> / <sub>8</sub> " x 19 <sup>1</sup> / <sub>8</sub> " x 17 <sup>1</sup> / <sub>8</sub> "	96 lbs.	Each <del>277.34</del>
Adjustable tray and bolt down hardware. Interior: 12 <sup>9</sup> / <sub>16</sub> " x 11 <sup>1</sup> / <sub>2</sub> " x 9 <sup>5</sup> / <sub>8</sub> ".					
8	SEN-SFW082CTB *	0.8 cu. ft.	16 <sup>1</sup> / <sub>16</sub> " x 19 <sup>1</sup> / <sub>16</sub> " x 13 <sup>3</sup> / <sub>32</sub> "	84 lbs.	Each <del>262.94</del>

\* SEN-SFW123CSB, SEN-SFW082CTB—Contains 10% post consumer recycled content in the steel.

**D DIGITAL DEPOSITORY SAFE**

Protect cash receipts, deposit slips, and other valuables against theft at the point of purchase. Solid steel construction. Anti-drill door. Anti-fish hopper. Bolt-down hardware included.

ID No.	Capacity	Exterior (W x D x H)	Shpg. Wt.	Unit	Price
<b>EXTRA LARGE</b> Interior: 13.70" x 11.30" x 14 <sup>1</sup> / <sub>2</sub> ".					
9	SEN-DH109E	1.09 cu. ft.	14" x 15 <sup>3</sup> / <sub>8</sub> " x 24"	110 lbs.	Each <del>652.44</del>
<b>LARGE</b> Interior: 13.70" x 11.30" x 10 <sup>1</sup> / <sub>2</sub> ".					
10	SEN-DH074E	0.94 cu. ft.	14" x 15 <sup>3</sup> / <sub>8</sub> " x 20"	99 lbs.	Each <del>577.99</del>

**E SMALL DEPOSITORY SAFE**

Dual-key access. Solid steel construction. Anti-fish hopper. Bolt-down hardware included. Interior: 5.8" x 10<sup>1</sup>/<sub>2</sub>" x 6<sup>1</sup>/<sub>2</sub>".

ID No.	Capacity	Exterior (W x D x H)	Shpg. Wt.	Unit	Price
11	SEN-UC025K	0.23 cu ft	6" x 12.3" x 8 <sup>1</sup> / <sub>2</sub> "	20 lbs.	Each <del>166.11</del>

Prices subject to change without notice.  
Visit our website for the latest pricing and product information.



## A ELECTRONIC SECURITY SAFE

Offers maximum security for valuables and electronics with solid steel construction, bolt down hardware, and a digital lock with key. Includes a removable shelf to help keep belongings organized. Interior: 16 $\frac{3}{4}$ " x 11 $\frac{1}{8}$ " x 8 $\frac{1}{16}$ ".

ID No.	Capacity	Exterior (W x D x H)	Shpg. Wt.	Unit	Price
1 SEN-X105	1.0 cu. ft.	16 $\frac{3}{4}$ " x 11 $\frac{1}{8}$ " x 8 $\frac{1}{16}$ "	26 lbs.	Each	472.46

## B ELECTRONIC/CARD SWIPE SECURITY SAFE

A smaller footprint and a wide range of convenience features and interior dimensions that provide versatility and strong protection for smaller but precious valuables. Solid steel construction with two live-locking bolts.

ID No.	Capacity	Exterior (W x D x H)	Shpg. Wt.	Unit	Price
<b>Digital locking system, Custom carpeted interior</b>					
2 SEN-X041E *	0.4 cu. ft.	15" x 11" x 7"	24 lbs.	Each	401.64
<b>Programmable digital lock plus override key</b>					
3 SEN-X014E *	1.1 cu. ft.	18" x 16" x 9"	34 lbs.	Each	56.72

\* SEN-X041E—Interior: 14 $\frac{1}{8}$ " x 7 $\frac{1}{8}$ " x 6 $\frac{1}{2}$ ".  
 SEN-X014E—Interior: 17 $\frac{1}{8}$ " x 12 $\frac{1}{8}$ " x 8 $\frac{1}{2}$ ".

## C WATERPROOF FIRE-RESISTANT FILE

UL Classified and ETL Verified to protect documents and digital media in the event of a fire or flood. Built to hold hanging file folders to provide easy organization of standard sized files or folders and can be easily transported with a convenient carrying handle. ETL Verified for 1/2-hour fire protection of Digital Media Devices up to 1550°F/843°C; ETL Verified for water submersion; UL Classified for Fire Endurance (1/2-hour at 1550°F/843°C). Interior: 12" x 8 $\frac{1}{8}$ " x 11 $\frac{1}{8}$ ".

ID No.	Capacity	Exterior (W x D x H)	Shpg. Wt.	Unit	Price
4 SEN-FHW40100	0.65 cu. ft.	16 $\frac{1}{2}$ " x 13 $\frac{1}{2}$ " x 14 $\frac{1}{2}$ "	44 lbs.	Each	424.75

## D WATERPROOF FIRE-RESISTANT CHEST

ETL Verified water protection and UL Classified fire protection, ideal for storage of important documents, certificates, passports and photos. ETL Verified to protect your digital media items and is equipped with a carrying handle for easy transportation. ETL Verified for 1-Hour Fire Rating for Digital Media Devices up to 1550°F/843°C; ETL Verified for Water Submersion; UL Classified for Fire Endurance (1-hour at 1550°F/843°C). Interior: 12 $\frac{1}{2}$ " x 8 $\frac{1}{2}$ " x 4 $\frac{1}{2}$ ".

ID No.	Capacity	Exterior (W x D x H)	Shpg. Wt.	Unit	Price
5 SEN-CFW20201	0.28 cu. ft.	15 $\frac{1}{2}$ " x 14 $\frac{1}{2}$ " x 6 $\frac{1}{2}$ "	30 lbs.	Each	70.11

## E WATERPROOF FIRE-RESISTANT CHEST

Perfect solution for protecting important documents and valuables from threats of fire, flood and theft. Privacy key lock security helps prevent unwanted access to items and a spacious interior and in-lid straps allow for safe, organized storage. Interior: 12" x 7 $\frac{1}{2}$ " x 3 $\frac{1}{2}$ ".

ID No.	Capacity	Exterior (W x D x H)	Shpg. Wt.	Unit	Price
6 SEN-HD2100	0.18 cu. ft.	14 $\frac{3}{8}$ " x 11 $\frac{1}{8}$ " x 6 $\frac{1}{8}$ "	24.4 lbs.	Each	67.02

## F FIRE-RESISTANT CHEST

Fire protection for most important belongings, privacy lock key for added security, and a carrying handle to safeguard valuables on the go. ETL Verified for half-hour fire rating for digital media devices up to 1550°F/843°C, UL Classified for fire endurance (1-hour at 1550°F/843°C). Interior: 12" x 7 $\frac{1}{2}$ " x 3 $\frac{1}{2}$ ".

ID No.	Capacity	Exterior (W x D x H)	Shpg. Wt.	Unit	Price
7 SEN-1200	0.18 cu. ft.	14 $\frac{3}{8}$ " x 11 $\frac{1}{8}$ " x 6 $\frac{1}{8}$ "	13.3 lbs.	Each	36.29

## G XX-LARGE WATER AND FIREPROOF COMMERCIAL SAFES

Strong protection and larger sizes to keep businesses up and running. Programmable electronic lock with override key. Oversize steel bolts. Thicker door for added security. Bolt-down kit included. Carpeted interior. Advanced fire protection – UL Classified for Fire Endurance (30 minutes), to protect documents, and valuables. ETL Verified 15 foot/4.5 meter drop test to ensure contents remain intact and locked upon impact. ETL Verified for 1-hour fire protection of CDs, DVDs, Memory Sticks and USB Drives. ETL Verified water-resistance in 12" of water for 72 hours.

ID No.	Capacity	Exterior (W x D x H)	Shpg. Wt.	Unit	Price
<b>THREE ADJUSTABLE SHELVES &amp; CARPETED INTERIOR</b> Interior: 19.4" x 11.7" x 35.7"					
8 SEN-EF4738E	4.71 cu ft	21.7" x 19" x 37.7"	217 lbs.	Each	656.00
<b>TWO ADJUSTABLE SHELVES &amp; CARPETED INTERIOR</b> Interior: 19 $\frac{3}{8}$ " x 11 $\frac{1}{4}$ " x 25 $\frac{3}{4}$ "					
9 SEN-EF3428E	3.4 cu ft	21 $\frac{3}{4}$ " x 19" x 27 $\frac{3}{4}$ "	169 lbs.	Each	743.14



### A DEPOSITORY SECURITY SAFE

Designed to protect cash receipts, deposits slips, keys and other valuables against theft at point of purchase. Programmable digital lock with time delay. Anti-fish hopper prevents contents from being removed.

ID No.	Capacity	Exterior (W × D × H)	Shpg. Wt.	Unit	Price
1 FIR-SB2414BLEL *	2.0 cu. ft.	14W × 14D × 24H	105 lbs.	Each	<del>1,200.00</del>
2 FIR-SB2014BLEL *	1.73 cu. ft.	14W × 14D × 20H	97 lbs.	Each	<del>960.00</del>

\* FIR-SB2414BLEL—Interior: 13.5W × 11D × 23.7H. Includes bolt down kit with pre-drilled anchor bolts.

FIR-SB2014BLEL—Interior: 13.5W × 11D × 20H.

### B SMALL PERSONAL SAFE

Compact safe for home or office use. Tough construction with programmable digital keypad provides security and easy access. Can be bolted to wall or floor. Interior: 12" × 5¾" × 7½". Batteries and installation kit included.

ID No.	Capacity	Exterior (W × D × H)	Shpg. Wt.	Unit	Price
3 FIR-HS1207 *	0.3 cu. ft.	12¼" × 7¾" × 7¾"	19 lbs.	Each	<del>147.00</del>

\* Batteries; installation kit included.



**Great Service**

We can help you with selection & solutions.



Designed to meet the security needs of today's consumer. Protects CDs/DVDs, flash drives, portable hard drives and other valuable items from fire and water damage. Dual compression latches and handle. Waterproof for two hours. Includes 2 keys.

### C FIRSS106 FIRE AND WATERPROOF CHEST

Holds letter and A4 size hanging file folders. Interior: 12½" × 8¾" × 10¼".

ID No.	Capacity	Exterior (W × D × H)	Shpg. Wt.	Unit	Price
4 FIR-SS106	0.60 cu. ft.	16" × 12½" × 13"	51 lbs.	Each	<del>275.00</del>

### D FIRSS104 FIRE AND WATERPROOF CHEST

Holds letter and legal-size files flat. Interior: 14½" × 12" × 3¾".

ID No.	Capacity	Exterior (W × D × H)	Shpg. Wt.	Unit	Price
5 FIR-SS104	0.38 cu. ft.	19¾" × 17" × 7¾"	56 lbs.	Each	<del>200.00</del>

### E FIRSS103 FIRE AND WATERPROOF CHEST

Holds letter and A4 size documents. Interior: 13¼" × 8½" × 3¾".

ID No.	Capacity	Exterior (W × D × H)	Shpg. Wt.	Unit	Price
6 FIR-SS103	0.27 cu. ft.	15¾" × 12¾" × 6½"	29 lbs.	Each	<del>170.00</del>

### F FIRSS102 FIRE AND WATERPROOF CHEST

Holds #10 envelopes and folded documents. Interior: 9¾" × 6" × 4½".

ID No.	Capacity	Exterior (W × D × H)	Shpg. Wt.	Unit	Price
7 FIR-SS102	0.15 cu. ft.	12½" × 9¾" × 7¾"	21 lbs.	Each	<del>117.00</del>

Prices subject to change without notice.

Visit our website for the latest pricing and product information.

**HON.**



## 310 Series Vertical File

Commercial-grade files to meet your long-lasting needs.

- Spring-loaded follower block in each drawer keeps files upright and neat.
- High-drawer sides add strength and serves as front-to-back hangrails.
- Thumb latch keeps drawers safely closed.
- Label holders for quick and easy identification of contents.
- HON "One Key" core removable locks.
- Steel ball bearing suspension.
- Backed by the HON Full Lifetime Warranty.
- Contains 12% pre-consumer recycled content, 24% post-consumer recycled content.
- Level 2 Certified; Meets or exceeds ANSI/BIFMA Standards; SCS Indoor Advantage Gold Certified.



Description	ID Black	ID Charcoal	ID Light Gray	ID Putty	W x D x H	Shpg. Wt.	Unit	Price
<b>A 5 DRAWERS</b>								
<b>Legal</b>	1 HON-315CPP	7 HON-315CPS	13 HON-315CPQ	19 HON-315CPL	18¼" x 26½" x 60"	137 lbs.	Each	<del>1,070.00</del>
<b>Letter</b>	2 HON-315PP	8 HON-315PS	14 HON-315PQ	20 HON-315PL	15" x 26½" x 60"	128 lbs.	Each	<del>924.00</del>
<b>B 4 DRAWERS</b>								
<b>Legal</b>	3 HON-314CPP	9 HON-314CPS	15 HON-314CPQ	21 HON-314CPL	18¼" x 26½" x 52"	116 lbs.	Each	<del>755.00</del>
<b>Letter</b>	4 HON-314PP	10 HON-314PS	16 HON-314PQ	22 HON-314PL	15" x 26½" x 52"	107 lbs.	Each	<del>629.00</del>
<b>C 2 DRAWERS</b>								
<b>Legal</b>	5 HON-312CPP	11 HON-312CPS	17 HON-312CPQ	23 HON-312CPL	18¼" x 26½" x 29"	66 lbs.	Each	<del>577.00</del>
<b>Letter</b>	6 HON-312PP	12 HON-312PS	18 HON-312PQ	24 HON-312PL	15" x 26½" x 29"	60 lbs.	Each	<del>463.00</del>

## 510 Series Vertical File

Vertical reinforcements keep the cabinet sturdy and the drawers gliding smoothly.

- Drawers open fully to provide easy access to contents.
- High drawer sides eliminate the need for hangrails.
- An adjustable wire follower in each drawer keeps files upright and neat.
- HON "One Key" core removable lock installed.
- Backed by the HON Full Lifetime Warranty.
- Contains 12% pre-consumer recycled content, 24% post-consumer recycled content.
- Level 2 Certified; Meets or exceeds ANSI/BIFMA Standards; SCS Indoor Advantage Gold Certified.



Description	ID Black	ID Light Gray	ID Putty	W x D x H	Shpg. Wt.	Unit	Price
<b>D 4 DRAWERS</b>							
<b>Legal</b>	25 HON-514CPP	29 HON-514CPQ	33 HON-514CPL	18¼" x 25" x 52"	112 lbs.	Each	<del>653.00</del>
<b>Letter</b>	26 HON-514PP	30 HON-514PQ	34 HON-514PL	15" x 25" x 52"	102 lbs.	Each	<del>543.00</del>
<b>E 2 DRAWERS</b>							
<b>Legal</b>	27 HON-512CPP	31 HON-512CPQ	35 HON-512CPL	18¼" x 25" x 29"	63 lbs.	Each	<del>506.00</del>
<b>Letter</b>	28 HON-512PP	32 HON-512PQ	36 HON-512PL	15" x 25" x 29"	58 lbs.	Each	<del>402.00</del>

ID ACCESSORIES FOR HON VERTICAL FILES

**F VERTICAL FILE LOCK KIT**—Easy-to-install lock kit requires no special tools. Order by key number to key all of your files alike. Chrome.

37 HON-F24	Each	58.00
------------	------	-------





## Four- & Two-Drawer Vertical File

- Wire follower block keeps files upright.
- High-sided drawers for hanging folders.
- Strong aluminum handle and thumb latch.
- Drawers extend fully for easy access to files.
- Drawers include hang rails for filing.
- Core removable lock allows files to be keyed-alike.
- Manufacturer's limited three-year warranty.
- Meets or exceeds ANSI/BIFMA Standards.



Description	ID Black	ID Putty	W x D x H	Shpg. Wt.	Unit	Price
<b>A 4 DRAWERS</b>						
<b>Legal</b>	1 ALE-VF1952BL	5 ALE-VF1952PY	18¼" x 25" x 52"	116 lbs.	Each	<del>537.00</del>
<b>Letter</b>	2 ALE-VF1552BL	6 ALE-VF1552PY	15" x 25" x 52"	107 lbs.	Each	<del>440.00</del>
<b>B 2 DRAWERS</b>						
<b>Legal</b>	3 ALE-VF1929BL	7 ALE-VF1929PY	18¼" x 25" x 29"	66 lbs.	Each	<del>324.00</del>
<b>Letter</b>	4 ALE-VF1529BL	8 ALE-VF1529PY	15" x 25" x 29"	60 lbs.	Each	<del>302.00</del>



## Brigade® Mobile Pedestal

Heavy-duty pedestals with radius pulls to complement Brigade 800 Series Lateral Files.

- Smooth ball bearing suspension; 90% extension on file drawer and box drawers.
- High-sided file drawer for front-to-back letter-size filing with crossrails included.
- HON "One Key" interchangeable lock core.
- Counterweight prevents tipping when opening more than one drawer.
- Fixed front casters; swivel back casters.
- Backed by the HON Full Lifetime Warranty.
- Contains 12% pre-consumer recycled content, 24% post-consumer recycled content.
- Level 2 Certified; Meets or exceeds ANSI/BIFMA Standards; SCS Indoor Advantage Gold Certified.

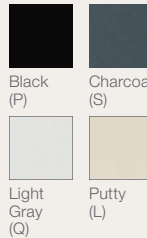

Description	ID Black	ID Charcoal	ID Light Gray	ID Putty	W x D x H	Shpg. Wt.	Unit	Price
<b>C 3 DRAWERS</b> —Box/Box/File, Pencil tray in top drawer.								
<b>22¾" Deep</b>	9 HON-33723RP	13 HON-33723RS	17 HON-33723RQ	21 HON-33723RL	15" x 22¾" x 28"	77 lbs.	Each	<del>610.00</del>
<b>19¾" Deep</b>	10 HON-33720RP	14 HON-33720RS	18 HON-33720RQ	22 HON-33720RL	15" x 19¾" x 28"	73 lbs.	Each	<del>594.00</del>
<b>D 2 DRAWERS</b> —File/File.								
<b>22¾" Deep</b>	11 HON-33823RP	15 HON-33823RS	19 HON-33823RQ	23 HON-33823RL	15" x 22¾" x 28"	77 lbs.	Each	<del>604.00</del>
<b>19¾" Deep</b>	12 HON-33820RP	16 HON-33820RS	20 HON-33820RQ	24 HON-33820RL	15" x 19¾" x 28"	73 lbs.	Each	<del>585.00</del>

### ACCESSORIES FOR HON BRIGADE® MOBILE PEDESTALS

**ADJUSTABLE PEDESTAL GLIDES**—Installable. Non-marring. Adjustable. (Not shown.)

ID No.	Stem	Qty.	Unit	Price
25 HON-20040AG	Plate Mount Rigid	4	Carton	<del>62.00</del>

## Mobile Pedestals

Delivers commercial office quality on an affordable budget.

- Steel frame construction for everyday use.
- Integrated handles create a clean appearance.
- Steel ball-bearing drawer suspensions operate easily and quietly.
- Backed by the HON Limited 5-year Warranty.
- Meets or exceeds ISTA Performance Standards.

Description	ID Black	ID Light Gray	ID Putty	W x D x H	Shpg. Wt.	Unit	Price
<b>E 3 DRAWERS</b>							
<b>20" Deep</b>	26 BSX-HBMP2BP	28 BSX-HBMP2BQ	30 BSX-HBMP2BL	15" x 20" x 28"	73 lbs.	Each	<del>410.00</del>
<b>F 2 DRAWERS</b>							
<b>20" Deep</b>	27 BSX-HBMP2FP	29 BSX-HBMP2FQ	31 BSX-HBMP2FL	15" x 20" x 28"	72 lbs.	Each	<del>410.00</del>



20-MF-L-FCL



## Metal Pedestal Files

Box drawers include one divider and pencil tray.

- High-sided file drawers include legal conversion bar.
- Counterweight prevents tipping.
- Core-changeable lock.
- Steel ball bearing slide suspension with ¾ extension on box drawers and full-length extension on file drawers.
- 26½" high if used without casters, 28" high with glides.
- Four caster (two locking) for mobility or four glides for stationary use.
- Manufacturer's limited five-year warranty.
- Meets or exceeds ANSI/BIFMA Standards.



Description	ID Black	ID Charcoal	ID Light Gray	ID Putty	W x D x H	Shpg. Wt.	Unit	Price
<b>A – C FILE PEDESTAL WITH FULL LENGTH RECESSED PULL</b>								
<b>A MOBILE</b> —Box/Box/File Pedestal, Two 6" high box drawers, one 12" high file drawer.								
<b>19½" Deep</b>	1 ALE-PBBFBFL	7 ALE-PBBFCH	13 ALE-PBBBFLG	19 ALE-PBBBFPY	14¾" x 19½" x 27¾"	77 lbs.	Each	<del>439.00</del>
<b>B MOBILE</b> —Box/Box/File Pedestal, One 6" high box drawer, one 12" high glide drawer.								
<b>19½" Deep</b>	2 ALE-PBBFBFL	8 ALE-PBBFCH	14 ALE-PBBBFLG	20 ALE-PBBBFPY	14¾" x 19½" x 21½"	66 lbs.	Each	<del>349.00</del>
<b>C MOBILE</b> —File/File Pedestal, Two 12" high file drawers.								
<b>19½" Deep</b>	3 ALE-PBFFBFL	9 ALE-PBFFCH	15 ALE-PBFFLFG	21 ALE-PBFFFPY	14¾" x 19½" x 27¾"	73 lbs.	Each	<del>419.00</del>
<b>D – F FILE PEDESTAL WITH RECESSED PULLS</b>								
<b>D MOBILE</b> —Box/Box/File Pedestal, Two 6" high box drawers, one 12" high file drawer.								
<b>19½" Deep</b>	4 ALE-PABBFBL	10 ALE-PABBFCH	16 ALE-PABBFLG	22 ALE-PABBFPY	14¾" x 19½" x 27¾"	79 lbs.	Each	<del>379.00</del>
<b>E MOBILE</b> —Box/File Pedestal, One 6" high box drawer and one 12" high file drawer.								
<b>19½" Deep</b>	5 ALE-PABFBFL	11 ALE-PABFCH	17 ALE-PABFLG	23 ALE-PABFPY	14¾" x 19½" x 21½"	66 lbs.	Each	<del>319.00</del>
<b>F MOBILE</b> —File/File Pedestal, Two 12" high file drawers.								
<b>19½" Deep</b>	6 ALE-PAFFBFL	12 ALE-PAFFCH	18 ALE-PAFFLFG	24 ALE-PAFFFPY	14¾" x 19½" x 27¾"	76 lbs.	Each	<del>359.00</del>

## Seat Cushion

- Add a cushion to the top of any Alera® Pedestal for instant seating.
- Soft, resilient foam covered in soft long-lasting fabric.
- Rubber grip bottom surface holds cushion in place without slipping, but is easily repositionable.
- 2" thick cushions offer just the right amount of support.
- Contains 10% post-consumer recycled content, 60% total recycled content. ♻️ ♻️

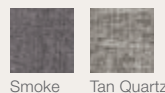

ID No.	W x D x H	Color	Qty.	Unit	Price
<b>G PEDESTAL FILE SEAT CUSHION</b>					
25 ALE-PC1511	14¾" x 19½" x 2½"	Smoke	1	Each	<del>87.00</del>
26 ALE-PC1551	14¾" x 19½" x 2½"	Tan Quartz	1	Each	<del>87.00</del>



## Alera® Valencia™ Series

Management office solutions featuring versatility to spare.

- Durable woodgrain laminate finishes.
- Commercial-grade 1" thick worksurface and side panels are water-, scratch- and dent-resistant, featuring protective edge banding.
- Five casters, two locking.
- Center caster prevents tipping.
- Fully assembled, just attach casters.
- Locking drawers with fold-away keys.
- Matching finishes with Valencia Series desk and bookcase components.
- Full-extension ball bearing slides on the file drawer for easy access.
- Manufacturer's limited five-year warranty.
- Meets or exceeds ANSI/BIFMA Standards.

ID No.	Color	W x D x H	Shpg. Wt.	Unit	Price
<b>A MOBILE FILE/FILE PEDESTAL</b>					
1	ALE-VA582816ES	Espresso	15¾" x 20" x 26¾"	68 lbs.	Each <del>459.00</del>
2	ALE-VA582816MY	Mahogany	15¾" x 20" x 26¾"	68 lbs.	Each <del>459.00</del>
3	ALE-VA582816MC	Medium Cherry	15¾" x 20" x 26¾"	68 lbs.	Each <del>459.00</del>
4	ALE-VA582816WA	Modern Walnut	15¾" x 20" x 26¾"	68 lbs.	Each <del>459.00</del>
<b>B MOBILE BOX/BOX/FILE PEDESTAL</b>					
5	ALE-VA572816ES	Espresso	15¾" x 20½" x 28¾"	77 lbs.	Each <del>459.00</del>
6	ALE-VA572816MY	Mahogany	15¾" x 20½" x 28¾"	77 lbs.	Each <del>459.00</del>
7	ALE-VA572816MC	Medium Cherry	15¾" x 20½" x 28¾"	77 lbs.	Each <del>459.00</del>
8	ALE-VA572816WA	Modern Walnut	15¾" x 20½" x 28¾"	77 lbs.	Each <del>459.00</del>
<b>C MOBILE BOX/FILE PEDESTAL</b> —Accepts Alera® Pedestal Cushions for an instant seating option.					
9	ALE-VABFES	Espresso	15¾" x 19¼" x 22¾"	55 lbs.	Each <del>375.00</del>
10	ALE-VABFMY	Mahogany	15¾" x 19¼" x 22¾"	55 lbs.	Each <del>375.00</del>
11	ALE-VABFMC	Medium Cherry	15¾" x 19¼" x 22¾"	55 lbs.	Each <del>375.00</del>
12	ALE-VABFWA	Modern Walnut	15¾" x 19¼" x 22¾"	55 lbs.	Each <del>375.00</del>



Valencia™ Series

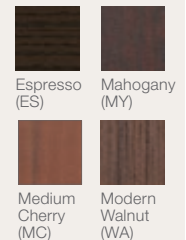

10500 Series™

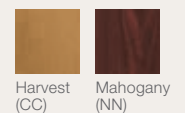

Trento Line

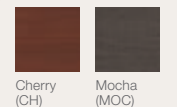

## HON 10500 Series™

The workhorse of the workplace.

- Durable, easy-care laminate is scratch-, spill- and stain-resistant.
- Drawers are equipped with smooth, quiet action slides.
- Strong inner frame construction built for trouble free performance and long life.
- Pedestals ship fully assembled.
- Backed by the HON Full Lifetime Warranty.
- Contains 69% pre-consumer recycled content, 3% post-consumer recycled content.
- Level 2 Certified; Meets or exceeds ANSI/BIFMA Standards; SCS Indoor Advantage Gold Certified.

ID No.	Color	W x D x H	Shpg. Wt.	Unit	Price
<b>D - E MOBILE PEDESTAL</b> —Store supplies and letter/legal size hanging files. Smooth, flat edges. Roll easily on hidden casters. Drawers lock. Use freestanding or under 24"D - 36"D Shells.					
<b>D MOBILE BOX/BOX/FILE PEDESTAL</b> —Top box drawer does not lock.					
13	HON-105102CC	Harvest	15¾" x 22¾" x 28"	121 lbs.	Each <del>654.00</del>
14	HON-105102NN	Mahogany	15¾" x 22¾" x 28"	121 lbs.	Each <del>654.00</del>
<b>E MOBILE FILE/FILE PEDESTAL</b> —Hang rails enable side-to-side letter and legal filing as well as front-to-back letter filing.					
15	HON-105104CC	Harvest	15¾" x 22¾" x 28"	121 lbs.	Each <del>654.00</del>
16	HON-105104NN	Mahogany	15¾" x 22¾" x 28"	121 lbs.	Each <del>654.00</del>



## Trento Line

Stylish minimalist design for universal appeal.

- Scratch- and stain-resistant woodgrain laminate with durable edge.
- Fully assembled.
- Full-extension locking metal drawers operate on steel ball bearing slides.
- Accommodate letter- and legal-size files.
- Four hooded dual-wheel casters for easy mobility.
- Manufacturer's limited five-year warranty.
- Meets or exceeds ANSI/BIFMA Standards.

ID No.	Color	W x D x H	Shpg. Wt.	Unit	Price
<b>F MOBILE PEDESTAL FILE 2 Drawers</b>					
17	LIT-TR752CH	Cherry	16½" x 19¼" x 23¾"	53 lbs.	Each <del>329.00</del>
18	LIT-TR752MOC	Mocha	16½" x 19¼" x 23¾"	53 lbs.	Each <del>329.00</del>

Prices subject to change without notice. Visit our website for the latest pricing and product information.



## Mobile Filing Cabinet with Metal Siding

### Who said filing can't be stylish?

- Built-in rails for letter sized hanging file folders.
- Built-in label holders on drawer fronts.
- Locking drawers keep contents safe.
- Easy sliding system for smooth drawer operation.
- Moves with ease from one area to another.
- Includes locking casters.
- Can be used under worksurface or as a freestanding unit.
- Manufacturer's limited 90-day warranty.
- Contains 25% post-consumer recycled content, 25% total recycled content. ♻️ ♻️

ID No.	Color	W × D × H	Shpg. Wt.	Unit	Price
<b>A MOBILE FILING CABINET WITH METAL SIDING</b>					
1	STX-61351U01C	Silver/Black	19" × 15" × 23"	25 lbs.	Each <del>151.75</del>
2	STX-61352U01C	Silver/Black	19" × 15" × 23"	25 lbs.	Each <del>153.95</del>

## Mobile Filing Cabinet

### Mobile cabinet accommodates letter- or legal-size files.

- Removable locking casters allow cabinet to be stacked on top of another cabinet for added storage capacity.
- Built-in rails for letter or legal sized hanging file folders
- Each drawer locks individually.
- Built-in label holders.
- Manufacturer's one-year warranty.
- Contains 25% post-consumer recycled content, 25% total recycled content. ♻️ ♻️

ID No.	Color	W × D × H	Shpg. Wt.	Unit	Price
<b>B TWO-DRAWER MOBILE FILING CABINET</b> —Drawers lock individually and feature a built-in label holder.					
3	STX-61312B01C	Black	14¾" × 18¼" × 26"	20 lbs.	Each <del>171.55</del>
4	STX-61314U01C	Black/Blue	14¾" × 18¼" × 26"	20 lbs.	Each <del>171.55</del>
5	STX-61315U01C	Black/Teal	14¾" × 18¼" × 26"	20 lbs.	Each <del>171.55</del>
6	STX-61310B01C	Gray	14¾" × 18¼" × 26"	20 lbs.	Each <del>171.55</del>
<b>C SINGLE-DRAWER MOBILE FILING CABINET</b> —Removable casters allow cabinet to be stacked on top of two-drawer mobile filing cabinet for added storage capacity.					
7	STX-61264B01C	Black	14¾" × 18¼" × 12¾"	9 lbs.	Each <del>100.65</del>
8	STX-61269U01C	Black/Blue	14¾" × 18¼" × 12¾"	9 lbs.	Each <del>100.65</del>
9	STX-61270U01C	Black/Teal	14¾" × 18¼" × 12¾"	9 lbs.	Each <del>100.65</del>
10	STX-61263U01C	Gray	14¾" × 18¼" × 12¾"	9 lbs.	Each <del>100.59</del>





**A DESK SIDE FILE CART**

Tubular frame with wire file supports. Accommodates letter or legal size folders. Wire grid bottom shelf for supplies. Scratch-resistant, powder-coated finish. Manufacturer's limited lifetime warranty. GREENGUARD Certified.

ID No.	Finish	W x D x H	Shpg. Wt.	Unit	Price
1 SAF-5224BL	Black	17½" x 13" x 22"	7 lbs.	Each	<del>66.00</del>



**B MOBILE FILE CART WITH DRAWERS**

Holds letter and legal size hanging file folders. Three drawers hold a wide assortment of items. Quick assembly requires no tools. Drawers measure 14½"w x 9½"d x 3¼"h.

ID No.	Finish	W x D x H	Shpg. Wt.	Unit	Price
2 VRT-VF50621	Black	38" x 15½" x 28"	20 lbs.	Each	<del>130.44</del>



**C MOBILE FILE CART WITH SLIDING BASKETS**

Easy-access suspension file cart fits under most worksurfaces. Sturdy all-metal frame with built-in hanging rails and four dual-wheel casters. Two pullout wire-grid baskets store supplies. Holds letter size hanging folders (not incl.)

ID No.	Finish	W x D x H	Shpg. Wt.	Unit	Price
3 AVT-34075	Black	12¾" x 15" x 21¼"	8 lbs.	Each	<del>62.00</del>

**D LETTER/LEGAL FILE CART WITH FIVE STORAGE DRAWERS**

This five-drawer cart includes three different size drawers to fit all your needs! Holds either letter or legal size files. Four swivel casters for easy mobility, two locking. High-tech metallic rails and knobs add style to appearance. Manufacturer's limited 90-day warranty.

ID No.	Finish	W x D x H	Shpg. Wt.	Unit	Price
4 AVT-34100	Black/Matte Gray	21¾" x 15¼" x 28¾"	12 lbs.	Each	<del>119.95</del>

**E PORTABLE DRAWER ORGANIZERS**

Convenient way to arrange and store your workload. Manufacturer's limited 90-day warranty.

ID No.	Finish	W x D x H	Shpg. Wt.	Unit	Price
<b>Ten-Drawer Organizer</b> —Ten small drawers. 37¾" high. Drawers are 10¼"w x 14¼"d x 2¾"h.					
5 AVT-34007	Smoke/Matte Gray	13" x 15¾" x 37¾"	16 lbs.	Each	<del>86.47</del>
6 AVT-34004	Assorted/Matte Gray	13" x 15¾" x 37¾"	14 lbs.	Each	<del>86.47</del>
<b>Six-Drawer Organizer</b> —32½" high. Four small drawers, each 10¼"w x 14¼"d x 2¾"h; two large drawers, each 10¼"w x 14¼"d x 5¼"h.					
7 AVT-34005	Smoke/Matte Gray	13" x 15¾" x 32½"	12 lbs.	Each	<del>86.47</del>
<b>Three-Drawer Organizer</b> —Three large drawers. 25¾" high. Drawers are 10¼"w x 14¼"d x 5¼"h.					
8 AVT-34006	Smoke/Matte Gray	13" x 15¾" x 25¾"	10 lbs.	Each	<del>74.09</del>

\* AVT-34004—Two Blue; Two Green; Two Orange; Two Purple; Two Red.



**F GO CART™ MOBILE FILE**

Versatile and adjustable literature trays for the storage of flat materials and tubs for hanging files. Six pull-out 9¾"w x 11¾"d shelves form up to eight letter size compartments to meet your personal filing needs. Fits neatly under most worksurfaces when not in use.

ID No.	Finish	W x D x H	Shpg. Wt.	Unit	Price
9 SAF-5390BL	Black	21¼" x 14½" x 26¼"	43 lbs.	Each	<del>296.00</del>



**G FOLDING MOBILE FILE CART**

Lightweight cart folds open to create a roomy option for storing and transporting files in included tote. Smooth-rolling casters for easy mobility. Folds flat to the size of a briefcase for convenient storage when not in use. Lower shelf accommodates additional supplies. Manufacturer's limited 90-day warranty.

ID No.	Finish	W x D x H	Shpg. Wt.	Unit	Price
10 AVT-55758	Black/Clear	14¼" x 18½" x 21¾"	7 lbs.	Each	<del>79.52</del>



### A COMPACT MOBILE WIRE FILE CART

Sturdy steel wire construction with scratch-resistant powder coat finish. Hanging file frame holds letter or legal size folders. Handy bottom shelf for supplies. Manufacturer's limited lifetime warranty.

ID No.	Finish	W × D × H	Shpg. Wt.	Unit	Price
1 SAF-5277BL	Black	15½" × 14" × 19¾"	9 lbs.	Each	<del>116.00</del>

### B WIRE MOBILE FILE

Extremely functional and versatile with a contemporary look and wire steel construction. Powder-coated finish for added durability. Designed to accommodate letter- or legal-size hanging file folders. Rolls easily so you can slide the cart under a worksurface and open up floor space. Manufacturer's limited lifetime warranty.

ID No.	Finish	W × D × H	Shpg. Wt.	Unit	Price
2 SAF-5201BL	Black	14" × 24" × 20½"	15 lbs.	Each	<del>124.00</del>

### C TWO-TIER ROLLING FILE CART

Two large full tiers of filing space to meet your filing needs. Cart accommodates letter and legal size files. Bottom shelf can be used for supplies storage if additional filing is not needed. Manufacturer's limited lifetime warranty.

ID No.	Finish	W × D × H	Shpg. Wt.	Unit	Price
3 SAF-5278BL	Black	25¾" × 14" × 29¾"	20 lbs.	Each	<del>204.00</del>



### D - F ROLLING FILE CART

Accommodates letter and legal size hanging files. Versatile front to back or side to side filing. Can be assembled with no tools in about 60 seconds. Lower shelf supports up to 150 lbs. Manufacturer's limited five-year warranty. Meets or exceeds ANSI/BIFMA Standards.

ID No.	Finish	W × D × H	Shpg. Wt.	Unit	Price
--------	--------	-----------	-----------	------	-------

#### D COMPACT FILE CART

4 ALE-FW601416BL	Black	15¼" × 12¾" × 21"	9 lbs.	Each	<del>158.00</del>
------------------	-------	-------------------	--------	------	-------------------

#### E SINGLE-TIER FILE CART—Side-to-side filing only.

5 ALE-FW60-1424BL	Black	24" × 14" × 21"	12 lbs.	Each	<del>109.00</del>
-------------------	-------	-----------------	---------	------	-------------------

#### F TWO-TIER FILE CART—Front-to-back and side-to-side filing.

6 ALE-FW60-1426BL	Black	26" × 14" × 29½"	17 lbs.	Each	<del>137.00</del>
-------------------	-------	------------------	---------	------	-------------------

### G CARRY-ALL CART/MAIL CART

7" deep top basket can accommodate letter- or legal-size files with included adjustable file rods. Sturdy bottom basket with 4" raised sides. Heavy-duty metal tube and wire construction resists scratches and withstands constant use. Snaps together in minutes without tools. Shelf and basket height adjustable in 1" increments. Manufacturer's limited five-year warranty.

ID No.	Finish	W × D × H	Shpg. Wt.	Unit	Price
7 ALE-MC3518SR	Silver	34¾" × 18" × 39½"	29 lbs.	Each	<del>369.00</del>



Laminate top doubles as additional workspace.

Available with or without a locking top.

Easy assembly. No tools required.



## A - C MOBILE TUB FILES

Sturdy steel construction ensures extreme durability. Powder-coated finish helps protect against scratches and dings. Four casters, two locking.

### A LOCKING MOBILE TUB FILE WITH DRAWER

Textured finish. Tub file on top with slide-away cover keeps dust out while securing files. File drawer below for additional storage. Both compartments are keyed alike. Four keys included.

ID No.	Finish	W x D x H	Shpg. Wt.	Unit	Price
<b>Legal Size</b>					
1	SAF-5365BL	Black	20" x 25½" x 27¾"	62 lbs.	Each <del>799.00</del>
<b>Letter Size</b>					
2	SAF-5364BL	Black	17" x 26" x 28"	59 lbs.	Each <del>609.00</del>

### B EXTRA-DEEP LOCKING MOBILE TUB FILE

Textured finish. Locking hinged cover keeps dust out while securing files. Handy bottom storage shelf.

ID No.	Finish	W x D x H	Shpg. Wt.	Unit	Price
<b>Legal Size</b>					
3	SAF-5363BL	Black	16½" x 24¾" x 28¼"	40 lbs.	Each <del>399.00</del>
<b>Letter Size</b>					
4	SAF-5362BL	Black	13½" x 24¾" x 28¼"	34 lbs.	Each <del>282.00</del>

### C STANDARD LOCKING MOBILE TUB FILE

Locking hinged cover keeps dust out while securing files. Handy bottom storage shelf.

ID No.	Finish	W x D x H	Shpg. Wt.	Unit	Price
<b>Letter Size</b>					
5	SAF-5361BL	Black	13½" x 19¼" x 28"	27 lbs.	Each <del>262.00</del>

### D SCOOT™ MOBILE FILE

Locking laminate top doubles as additional workspace. Two side pockets offer easy access to active files. Bottom shelf provides additional storage space. Accommodates letter/legal-size hanging files.

ID No.	Finish	W x D x H	Shpg. Wt.	Unit	Price
6	SAF-5370BL	Black/Silver	29¾" x 18¾" x 27"	44 lbs.	Each <del>424.00</del>

### E SCOOT™ OPEN TOP MOBILE FILE CART

Accommodates letter/legal-size hanging files. Side pockets on either end for active files. Shelf on bottom for additional storage. Manufacturer's limited lifetime warranty.

ID No.	Finish	W x D x H	Shpg. Wt.	Unit	Price
7	SAF-5373BL	Black/Silver	28" x 14¾" x 26"	29 lbs.	Each <del>369.00</del>

### F LOCKING TOP MOBILE TUB FILE

Sturdy steel construction with mesh sides and scratch-resistant powder coat finish. Accommodates letter or legal size hanging files. Locking cover helps keep files dust-free and secure. Manufacturer's limited lifetime warranty.

ID No.	Finish	W x D x H	Shpg. Wt.	Unit	Price
8	SAF-5353BL	Black	33¾" x 17" x 27"	45 lbs.	Each <del>486.00</del>

### G OPEN TOP MESH TUB

Open design for easy access to contents. Holds letter sized hanging folders. Shelf on bottom for additional storage. Manufacturer's limited lifetime warranty.

ID No.	Finish	W x D x H	Shpg. Wt.	Unit	Price
9	SAF-5350BL	Black	13½" x 24¼" x 27½"	23 lbs.	Each <del>299.00</del>

## VERTIFLEX

### H INSTACART® FILE CART

Open top file cart assembles in seconds with no tools required! Provides quick access to letter-size hanging file folders. Durable steel and wire construction with convenient bottom storage shelf for paper and supplies. Four casters, two locking.

ID No.	Finish	W x D x H	Shpg. Wt.	Unit	Price
10	VRT-VF53000	Black	14¼" x 28½" x 27¾"	20 lbs.	Each <del>179.95</del>

### I - J FILE CARTS

For letter-size hanging file folders. Sliding file rails adjust to hold legal size file folders. Durable steel and wire construction. Four twin-wheel casters, two locking.

### I SIDEKICK FILE CART

Durable steel and wire construction. Holds letter-size hanging file folders. Bottom shelf stores papers and supplies.

ID No.	Finish	W x D x H	Shpg. Wt.	Unit	Price
11	VRT-VF52002	Matte Gray	13¾" x 15½" x 26¼"	15 lbs.	Each <del>144.99</del>

### J FILE CARTS

ID No.	Finish	W x D x H	Shpg. Wt.	Unit	Price
<b>With Open Top</b>					
12	VRT-VF52000	Matte Gray	28¼" x 13¾" x 27¾"	22 lbs.	Each <del>244.95</del>
<b>With Key Lock Sliding Top</b> —Locking top panels slide out of the way for full access to files and can be used as auxiliary work surfaces. Includes two keys.					
13	VRT-VF52001	Matte Gray	29¼" x 14" x 28¾"	30 lbs.	Each <del>326.99</del>

Prices subject to change without notice. Visit our website for the latest pricing and product information.





## Onyx™ Mesh Storage

Quick and easy assembly with no tools required.

- Manufacturer's limited lifetime warranty.
- GREENGUARD Certified.

ID No.	Color	W × D × H	Shpg. Wt.	Unit	Price
--------	-------	-----------	-----------	------	-------

**A ONYX™ MESH CUBE**—Steel mesh cube with four 14" square compartments helps organize your workspace in style. Supports up to 80 lbs. and stacks up to three high. Collapses for compact storage when not in use. Compatible with Onyx™ Mesh Cube Bins.

1 SAF-2172BL Black 28½" × 14½" × 28½" 15.5 lbs. Each ~~421.00~~

**B ONYX™ MESH CUBE BINS**—Steel mesh cube bins come in a pack of two each. Use alone or slide into the Onyx™ Mesh Cube for storage versatility. Collapses for compact storage when not in use.

2 SAF-2173BL Black 12½" × 14" × 10" 7 lbs. Pack ~~54.00~~

ID No.	Compartments	Color	W × D × H	Unit	Price
--------	--------------	-------	-----------	------	-------

**C ONYX™ HANGING ORGANIZERS**

**Attaches via Hex Head Clamp**—Hardware included.

3 SAF-3242BL 4 Black 10¼" × 12¾" × 12" Each ~~57.00~~

4 SAF-3243BL 3 Black 9½" × 12" × 14¾" Each ~~57.00~~

**Mounted Under Desk via Screws**—Hardware included.

5 SAF-3244BL 3 Black 10¼" × 12¾" × 7¼" Each ~~55.00~~

## Onyx™ Mesh Mobile Files

Durable, tubular steel mesh provides stylish yet practical organization.

- Black powder coat finish for durability.
- Easily fits under work surface when not needed.
- Four casters (two locking) for mobility.
- Collapsible drawers make assembly quick and easy.
- GREENGUARD Certified.

ID No.	Finish	W × D × H	Shpg. Wt.	Unit	Price
--------	--------	-----------	-----------	------	-------

**D ONYX™ MESH MOBILE FILE WITH FOUR SUPPLY DRAWERS**—Mobile file with four letter-size storage drawers keep office essentials easily accessible and organized. Top shelf offers additional storage.

6 SAF-5214BL Black 15¾" × 17" × 27" 23 lbs. Each ~~183.00~~

**E ONYX™ MESH MOBILE FILE WITH TWO SUPPLY DRAWERS**—Convenient letter-size file cube and two supply drawers slide easily on powder coat steel channels. Top shelf offers additional storage for supplies.

7 SAF-5213BL Black 15¾" × 17" × 27" 21 lbs. Each ~~170.00~~

**F ONYX™ MESH MOBILE FILE CUBE**—Durable, tubular steel mesh provides practical organization. Convenient letter-size cube casters (two locking) for mobility.

8 SAF-5211BL Black 13½" × 16¾" × 13" 7 lbs. Each ~~72.00~~

**G ONYX™ MESH MOBILE FILE**—Tubular steel frame cart with open hanging files and two storage drawers keep office essentials easily accessible and organized.

9 SAF-5215BL Black 15¾" × 17" × 27" 15 lbs. Each ~~156.00~~

**H ONYX™ MESH MOBILE DOUBLE FILE**—Convenient letter-size file cubes slide easily on powder coat (for durability) steel channels. Top shelf offers additional storage.

10 SAF-5212BL Black 15¾" × 17" × 27" 17.5 lbs. Each ~~158.00~~



## Multimedia Cabinets

An effective way to manage your technology data or media files.

- Full-extension, full-suspension steel files.
- 26¾" deep filing capacity, one center divider and two follower blocks per drawers.
- One lock secures all drawers.
- Aluminum label holders and thumb latches.
- Contains 19% post-consumer recycled content, 25% total recycled content.
- SCS Indoor Advantage Gold Certified.



Black (BK)



Putty (PY)

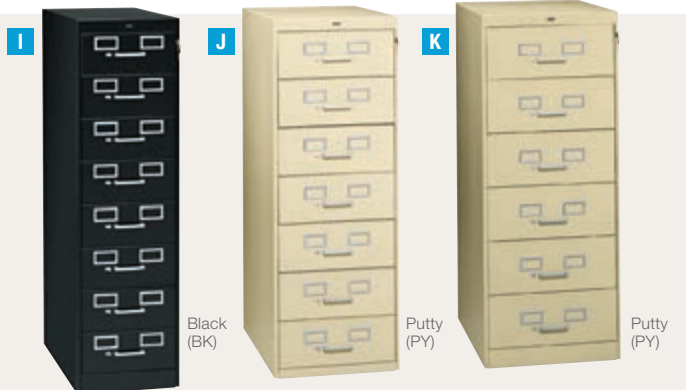

Description	ID	Black	Putty	W × D × H	Shpg. Wt.	Unit	Price
-------------	----	-------	-------	-----------	-----------	------	-------

**I EIGHT-DRAWER MULTIMEDIA/CARD FILE CABINET** 11 TNN-CF846BK 14 TNN-CF846PY 15" × 28½" × 52" 216 lbs. Each ~~1,644.00~~

**J SEVEN-DRAWER MULTIMEDIA/CARD FILE CABINET** 12 TNN-CF758BK 15 TNN-CF758PY 19¾" × 28½" × 52" 215 lbs. Each ~~1,560.00~~

**K SIX-DRAWER MULTIMEDIA/CARD FILE CABINET** 13 TNN-CF669BK 16 TNN-CF669PY 21¼" × 28½" × 52" 209 lbs. Each ~~1,499.00~~



# Storage

Find a place for everything to create order out of chaos.



**Smart storage makes the difference** between a well-ordered, productive workspace and wasted space and time. Clear away the clutter and you'll clear the way to get more done. Our wide range of storage solutions lets you organize everything from office supplies to food to personal items to tools so you can spend less time searching and more time on what matters.

Bookcases	184-188
Cabinets	189-191
Shelving	192-197
Lockers	198-200



Mahogany (MY)  
 Medium Cherry (MC)



## Veneer Bookcases

Rich wood veneer bookcases with fully-finished backs.

- Sturdy 1" thick shelves support up to 95 lbs each.
- 11 $\frac{3}{8}$ " deep shelves store large publications.
- UV veneer finish provides scratch and spill resistance.
- Shelves adjust in 1/4" increments.
- Shelf count includes bottom of bookcase.
- Wood veneer bookcases with square corners.
- Manufacturer's limited five-year warranty.
- Meets or exceeds ANSI/BIFMA Standards.



Description	ID Mahogany	ID Medium Cherry	W x D x H	Shpg. Wt.	Unit	Price
<b>A VENEER SQUARE CORNER BOOKCASE</b>						
<b>7 Shelves</b>	1 ALE-BCS78436MY	6 ALE-BCS78436MC	35 $\frac{1}{2}$ " x 11 $\frac{3}{4}$ " x 84"	136 lbs.	Each	<del>925.00</del>
<b>6 Shelves</b>	2 ALE-BCS67236MY	7 ALE-BCS67236MC	35 $\frac{1}{2}$ " x 11 $\frac{3}{4}$ " x 72"	116 lbs.	Each	<del>769.00</del>
<b>5 Shelves</b>	3 ALE-BCS56036MY	8 ALE-BCS56036MC	35 $\frac{1}{2}$ " x 11 $\frac{3}{4}$ " x 60"	103 lbs.	Each	<del>669.00</del>
<b>3 Shelves</b>	4 ALE-BCS33636MY	9 ALE-BCS33636MC	35 $\frac{1}{2}$ " x 11 $\frac{3}{4}$ " x 36"	68 lbs.	Each	<del>419.00</del>
<b>B NARROW PROFILE BOOKCASE WITH FINISHED BACK</b>						
<b>6 Shelves</b>	5 ALE-BCS67212MY	10 ALE-BCS67212MC	12" x 11 $\frac{3}{4}$ " x 72"	65 lbs.	Each	<del>399.00</del>



## Alera® Valencia™ Series Bookcase

Contemporary design; woodgrain laminate construction.

- Commercial-grade panels are water-, scratch- and dent-resistant, with protective 3 mm edge banding.
- 11¾" deep adjustable shelves.
- Top panel is 14" deep for door installation.
- Tight, dowel and cam-lock assembly.
- Matching components with Valencia Office Suites.
- Manufacturer's limited five-year warranty.
- Meets or Exceeds ANSI/BIFMA Standards.



Espresso (ES)



Mahogany (MY)



Medium Cherry (MC)



Modern Walnut (WA)

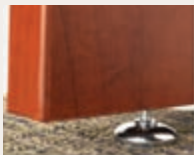

Metal leveling glides compensate for uneven floors.

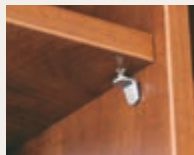

Locking shelf supports.

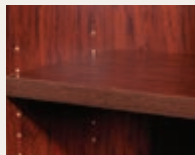

Commercial-grade shelves resist bowing.

Description	ID Espresso	ID Mahogany	ID Medium Cherry	ID Modern Walnut	W x D x H	Shpg. Wt.	Unit	Price
<b>Six Shelves</b>	1 ALE-VA638232ES	6 ALE-VA63-8232MY	11 ALE-VA63-8232MC	16 ALE-VA638232WA	31¾" x 14" x 80%"	151 lbs.	Each	<del>525.00</del>
<b>Five Shelves</b>	2 ALE-VA636632ES	7 ALE-VA63-6632MY	12 ALE-VA63-6632MC	17 ALE-VA636632WA	31¾" x 14" x 65"	129 lbs.	Each	<del>411.00</del>
<b>Four Shelves</b>	3 ALE-VA635632ES	8 ALE-VA63-5632MY	13 ALE-VA63-5632MC	18 ALE-VA635632WA	31¾" x 14" x 55"	109 lbs.	Each	<del>350.00</del>
<b>Three Shelves</b>	4 ALE-VA634432ES	9 ALE-VA63-4432MY	14 ALE-VA63-4432MC	19 ALE-VA634432WA	31¾" x 14" x 39%"	82 lbs.	Each	<del>200.00</del>
<b>Two Shelves</b>	5 ALE-VA633032ES	10 ALE-VA63-3032MY	15 ALE-VA63-3032MC	20 ALE-VA633032WA	31¾" x 14" x 29½"	63 lbs.	Each	<del>265.00</del>

Prices subject to change without notice. Visit our website for the latest pricing and product information.



# Storage Bookcases/Laminate



Traditional square edge for a simple, clean look.



**HON.**

## 1800 Series Laminate Bookcases

**Durable construction plus clean lines equal classic storage style.**

- Contemporary, adjustable shelf bookcase.
- ¾" thick shelves adjust in 1¼" increments to meet a variety of storage needs.
- Long-lasting wear-resistant laminate with durable PVC edges.
- Four adjustable leveling glides.
- Backed by the HON Full Lifetime Warranty.
- Contains 69% pre-consumer recycled content, 3% post-consumer recycled content.
- Meets or Exceeds ANSI/BIFMA Standards and ISTA Performance Standards; SCS Indoor Advantage Gold Certified.



### Special Order

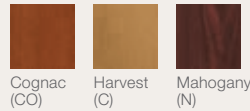

Requires additional lead time and cannot be returned.

Description	ID Cognac	ID Harvest	ID Mahogany	W x D x H	Shpg. Wt.	Unit	Price
<b>1870 SERIES LAMINATE BOOKCASE WITH SQUARE EDGE</b> —Durable construction plus clean lines equal classic storage style. Adjustable shelf bookcase. Long lasting wear-resistant laminate with durable PVC edges. Four adjustable leveling glides.							
<b>Six Shelves</b> —Four Adjustable	1 HON-1877CO	7 HON-1877C	13 HON-1877N	36" x 11½" x 84"	124 lbs.	Each	400.00
<b>Six Shelves</b> —Four Adjustable	2 HON-1876CO	8 HON-1876C	14 HON-1876N	36" x 11½" x 72½"	109 lbs.	Each	422.00
<b>Five Shelves</b> —Three Adjustable	3 HON-1875CO	9 HON-1875C	15 HON-1875N	36" x 11½" x 60½"	92 lbs.	Each	301.00
<b>Four Shelves</b> —Three Adjustable	4 HON-1874CO	10 HON-1874C	16 HON-1874N	36" x 11½" x 48¾"	77 lbs.	Each	324.00
<b>Three Shelves</b> —Two Adjustable	5 HON-1872CO	11 HON-1872C	17 HON-1872N	36" x 11½" x 36½"	60 lbs.	Each	258.00
<b>Two Shelves</b> —One Adjustable	6 HON-1871CO	12 HON-1871C	18 HON-1871N	36" x 11½" x 29¾"	48 lbs.	Each	233.00



For 10700 Series Laminate Desking and components, see pages 8-9.



Rounded, waterfall-shaped edges and corners.

**HON.**

## 10700 Series™ Laminate Bookcases

**Iconic Design, Lasting Performance.**

- Ships fully assembled.
- Long-lasting, durable, abrasion- and stain-resistant surfaces.
- Fixed shelves; shelf count includes bottom of bookcase.
- Four adjustable leveling glides.
- Fully finished back.
- Backed by the HON Full Lifetime Warranty.
- Contains 69% pre-consumer recycled content, 3% post-consumer recycled content.
- Level 2 Certified; Meets or Exceeds ANSI/BIFMA and ISTA Performance Standards; SCS Indoor Advantage Certified.



Description	ID Cognac	ID Harvest	ID Mahogany	W x D x H	Shpg. Wt.	Unit	Price
<b>BOOKCASES</b> —Fixed shelves. Full-finished back. Shelf count includes bottom of bookcase. No assembly required.							
<b>A Five Shelves</b> —Fixed	19 HON-10755CO	23 HON-10755CC	27 HON-10755NN	36" x 13½" x 71"	187 lbs.	Each	400.00
<b>B Four Shelves</b> —Fixed	20 HON-10754CO	24 HON-10754CC	28 HON-10754NN	36" x 13½" x 57½"	156 lbs.	Each	350.00
<b>C Three Shelves</b> —Fixed	21 HON-10753CO	25 HON-10753CC	29 HON-10753NN	36" x 13½" x 43¾"	122 lbs.	Each	254.00
<b>D Two Shelves</b> —Fixed	22 HON-10752CO	26 HON-10752CC	30 HON-10752NN	36" x 13½" x 29¾"	90 lbs.	Each	225.00





For 10500 Series Laminate Desking and components, see pages 10-15.

## HON



### 10500 Series™ Laminate Bookcase

Versatile, hard-working, good-looking and built to survive a lifetime of overtime.

- Shipped fully assembled.
- Long-lasting, durable abrasion- and stain-resistant surfaces.
- Fixed shelves; shelf count includes bottom of bookcase.
- Four adjustable leveling glides.
- Fully finished back.
- Backed by the HON Full Lifetime Warranty.
- Contains 69% pre-consumer recycled content, 3% post-consumer.
- Level 2 Certified; Meets or exceeds ANSI/BIFMA Standards; SCS Indoor Advantage Gold Certified.



Description	ID Harvest	ID Mahogany	W x D x H	Shpg. Wt.	Unit	Price
<b>LAMINATE BOOKCASE</b> —Fixed shelves. No assembly required.						
<b>A 5 Shelves</b>	1 HON-105535CC	5 HON-105535NN	36" x 13½" x 71"	187 lbs.	Each	<del>825.00</del>
<b>B 4 Shelves</b>	2 HON-105534CC	6 HON-105534NN	36" x 13½" x 57½"	156 lbs.	Each	<del>710.00</del>
<b>C 3 Shelves</b>	3 HON-105533CC	7 HON-105533NN	36" x 13½" x 43½"	122 lbs.	Each	<del>602.00</del>
<b>D 2 Shelves</b>	4 HON-105532CC	8 HON-105532NN	36" x 13½" x 29½"	90 lbs.	Each	<del>474.00</del>



**tensco**  
Storage Made Easy



### Assembled Metal Bookcases

Commercial-grade steel construction provides years of reliable storage.

- Shelves adjust in 2" increments.
- Powder-coated finish.
- Rounded top edge.
- Ships fully assembled.
- Contains 19% post-consumer recycled content, 25% total recycled content.
- Meets or exceeds ANSI/BIFMA Standards; SCS Indoor Advantage Gold Certified.

Description	ID Black	ID Putty	W x D x H	Shpg. Wt.	Unit	Price
<b>METAL BOOKCASES</b>						
<b>E 6 Shelves</b>	9 TNN-B78BK	14 TNN-B78PY	34½" x 13½" x 78"	101 lbs.	Each	<del>977.00</del>
<b>F 5 Shelves</b>	10 TNN-B66BK	15 TNN-B66PY	34½" x 13½" x 66"	89 lbs.	Each	<del>930.00</del>
<b>G 4 Shelves</b>	11 TNN-B53BK	16 TNN-B53PY	34½" x 13½" x 52½"	76 lbs.	Each	<del>807.00</del>
<b>H 3 Shelves</b>	12 TNN-B42BK	17 TNN-B42PY	34½" x 13½" x 40"	58 lbs.	Each	<del>225.00</del>
<b>I 2 Shelves</b>	13 TNN-B30BK	18 TNN-B30PY	34½" x 13½" x 28"	45 lbs.	Each	<del>107.00</del>

# Storage Bookcases/Steel



Depth accommodates three-ring binders.



Adjustable shelves.

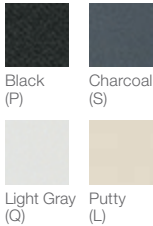

Black (P) Charcoal (S)  
Light Gray (Q) Putty (L)



Light Gray

Black

Putty

Charcoal

**HON.**

## Brigade® Steel Bookcases

Handsome, high-quality steel units store books, binders and office supplies.

- Straight sides and backs allow flush alignment.
- Baked enamel finish over rust-inhibiting pre-treatment.
- Bookcase ships assembled.
- Backed by the HON Full Lifetime Warranty.
- Shelves adjust in 1/2" increments.
- Shelf count includes bottom of bookcase.
- Contains 12% pre-consumer recycled content, 24% post-consumer recycled content.
- Level 2 Certified; Meets or Exceeds ANSI/BIFMA Standards; SCS Indoor Advantage Gold Certified. Contains 12% pre-consumer recycled content, 24% post-consumer recycled content.



Description	ID	Black	ID	Charcoal	ID	Light Gray	ID	Putty	W x D x H	Shpg. Wt.	Unit	Price
<b>SIX SHELVES</b> —Four Adjustable	1	HON-S82ABCP	6	HON-S82ABCS	11	HON-S82ABCQ	16	HON-S82ABCL	34½"x12¾"x81½"	97 lbs.	Each	740.00
<b>FIVE SHELVES</b> —Four Adjustable	2	HON-S72ABCP	7	HON-S72ABCS	12	HON-S72ABCQ	17	HON-S72ABCL	34½"x12¾"x71"	87 lbs.	Each	489.00
<b>FOUR SHELVES</b> —Three Adjustable	3	HON-S60ABCP	8	HON-S60ABCS	13	HON-S60ABCQ	18	HON-S60ABCL	34½"x12¾"x59"	77 lbs.	Each	430.00
<b>THREE SHELVES</b> —Two Adjustable	4	HON-S42ABCP	9	HON-S42ABCS	14	HON-S42ABCQ	19	HON-S42ABCL	34½"x12¾"x41"	57 lbs.	Each	280.00
<b>TWO SHELVES</b> —One Adjustable	5	HON-S30ABCP	10	HON-S30ABCS	15	HON-S30ABCQ	20	HON-S30ABCL	34½"x12¾"x29"	44 lbs.	Each	240.00

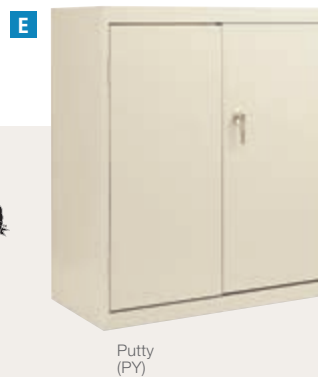
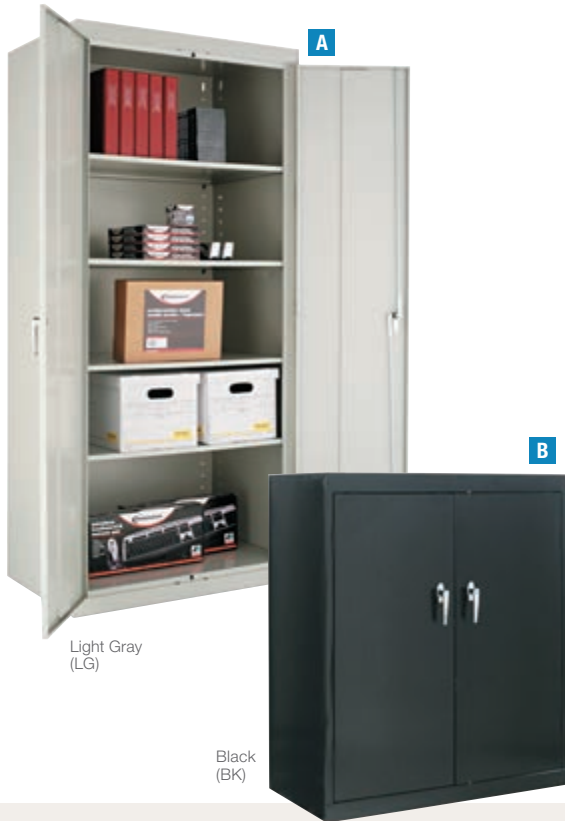

## Heavy Duty Welded Storage Cabinets

Shelves adjust in 2" increments. Reinforced doors with satin chrome double handles open 180°. Secure three-point locking rod system locks top, bottom and doors. Industrial-grade steel with powder coat finish. Sturdy 16 gauge door frame prevents racking. Heavy duty secure knuckle hinges for longevity. Leveling glides compensate for uneven floors. Manufacturer's limited five-year warranty.

ID No.	Color	W x D x H	Shpg. Wt.	Unit	Price
<b>A 78" HIGH CABINET</b> —Four adjustable shelves.					
1	ALE-CM7824BK	Black	36" x 24" x 78"	178 lbs.	Each <del>1,137.00</del>
2	ALE-CM7824LG	Light Gray	36" x 24" x 78"	178 lbs.	Each <del>1,137.00</del>
3	ALE-CM7824PY	Putty	36" x 24" x 78"	178 lbs.	Each <del>1,137.00</del>
<b>72" HIGH CABINET</b> —Four adjustable shelves.					
4	ALE-CM7218BK	Black	36" x 18" x 72"	145 lbs.	Each <del>894.00</del>
5	ALE-CM7218LG	Light Gray	36" x 18" x 72"	145 lbs.	Each <del>894.00</del>
6	ALE-CM7218PY	Putty	36" x 18" x 72"	145 lbs.	Each <del>894.00</del>
<b>B 42" HIGH CABINET</b> —Two adjustable shelves.					
7	ALE-CM4218BK	Black	36" x 18" x 42"	92 lbs.	Each <del>678.00</del>
8	ALE-CM4218LG	Light Gray	36" x 18" x 42"	92 lbs.	Each <del>678.00</del>
9	ALE-CM4218PY	Putty	36" x 18" x 42"	92 lbs.	Each <del>678.00</del>

### C SPACE SAVER ASSEMBLED STORAGE CABINET

Industrial grade steel cabinet with powder coat putty finish works best where space is at a premium. Secure three-point locking system locks top, bottom and doors. Narrower depth allows use in tight areas; shorter height is ideal for use next to panel systems. Four adjustable shelves. Recessed locking handle. Manufacturer's limited five-year warranty.

ID No.	Color	W x D x H	Shpg. Wt.	Unit	Price
10	ALE-CM6615PY	Putty	30" x 15" x 66"	77 lbs.	Each <del>894.00</del>

### D - E ECONOMY ASSEMBLED STORAGE CABINET

Industrial grade steel with powder coat finish and polished chrome handle. Secure three point locking system locks top, bottom and doors. Adjustable shelves adjust in 2" increments. Reinforced doors open 180°. Manufacturer's limited five-year warranty.

ID No.	Color	W x D x H	Shpg. Wt.	Unit	Price
<b>D 72" HIGH CABINET</b> —One fixed and three adjustable shelves.					
11	ALE-CME7218PY	Putty	36" x 18" x 72"	121 lbs.	Each <del>744.00</del>
<b>E 42" HIGH CABINET</b> —Two fixed shelves.					
12	ALE-CME4218PY	Putty	36" x 18" x 42"	76 lbs.	Each <del>545.00</del>

### F ASSEMBLED MOBILE STORAGE CABINET

Fully enclosed, fully assembled industrial grade welded steel cabinets hold up to 900 lbs. Secure three-point locking bar system locks top, bottom and doors. Reinforced doors with recessed handles open 180°. Heavy-duty caster base has four 5" casters, two locking. Manufacturer's limited five-year warranty.

ID No.	Color	W x D x H	Shpg. Wt.	Unit	Price
<b>Three Adjustable Shelves</b>					
13	ALE-CM6624PY	Putty	36" x 24" x 66"	162 lbs.	Each <del>1,259.00</del>

Prices subject to change without notice.

Visit our website for the latest pricing and product information.

# Storage Cabinets



A - C

Putty (L)

Black (P)



D

Putty (PY)

Black (BK)

E

**HON.**

## Brigade® Assembled Storage Cabinet

Assembled industrial-grade steel cabinets.

- HON "One Key" interchangeable lock core.
- Reinforced base with leveling glides.
- Tough construction provides extreme durability.
- Satin Chrome double handles with three-point locking system.
- Shelves adjust in 2" increments to accommodate different sized materials and are tested to 250 lbs.
- Backed by the HON Full Lifetime Warranty.
- Contains 12% pre-consumer recycled content, 24% post-consumer recycled content.



ID No.	Color	W x D x H	Shpg. Wt.	Unit	Price
<b>A 36W x 24½D x 71¼H CABINET</b> —Five adjustable shelves.					
1	HON-SC2472P	Black	36" x 24½" x 71¼"	149 lbs.	Each <del>1,100.00</del>
2	HON-SC2472S	Charcoal	36" x 24½" x 71¼"	149 lbs.	Each <del>1,188.00</del>
3	HON-SC2472Q	Light Gray	36" x 24½" x 71¼"	149 lbs.	Each <del>1,100.00</del>
4	HON-SC2472L	Putty	36" x 24½" x 71¼"	149 lbs.	Each <del>1,100.00</del>
<b>B 36W x 18½D x 71¼H CABINET</b> —Five adjustable shelves.					
5	HON-SC1872P	Black	36" x 18½" x 71¼"	131 lbs.	Each <del>947.00</del>
6	HON-SC1872S	Charcoal	36" x 18½" x 71¼"	131 lbs.	Each <del>947.00</del>
7	HON-SC1872Q	Light Gray	36" x 18½" x 71¼"	131 lbs.	Each <del>947.00</del>
8	HON-SC1872L	Putty	36" x 18½" x 71¼"	131 lbs.	Each <del>947.00</del>
<b>C 36W x 18½D x 41¼H CABINET</b> —Two adjustable shelves.					
9	HON-SC1842P	Black	36" x 18½" x 41¼"	82 lbs.	Each <del>800.00</del>
10	HON-SC1842S	Charcoal	36" x 18½" x 41¼"	82 lbs.	Each <del>800.00</del>
11	HON-SC1842Q	Light Gray	36" x 18½" x 41¼"	82 lbs.	Each <del>800.00</del>
12	HON-SC1842L	Putty	36" x 18½" x 41¼"	82 lbs.	Each <del>800.00</del>



**tensco**  
Storage Made Easy



## Storage Cabinets

### D ASSEMBLED JUMBO COMBINATION STORAGE CABINET

Fully welded steel construction with sturdy box-formed shelves. Full-width top shelf, four adjustable side shelves and 23¾" wide wardrobe rod. Heavy-duty leaf hinges and secure three-point locking system. Manufacturer's limited one-year warranty. Contains 19% post-consumer recycled content, 25% total recycled content.

ID No.	Color	W x D x H	Shpg. Wt.	Unit	Price
13	TNN-J2478SUBK	Black	48" x 24" x 78"	230 lbs.	Each <del>1,099.00</del>
14	TNN-J2478SULGY	Light Gray	48" x 24" x 78"	230 lbs.	Each <del>1,099.00</del>
15	TNN-J2478SUPY	Putty	48" x 24" x 78"	230 lbs.	Each <del>1,099.00</del>

### E ASSEMBLED JUMBO STEEL STORAGE CABINET

Heavy-gauge welded steel and sturdy box-formed construction. Four adjustable shelves with built-in support tab. Each shelf holds up to 400 lbs. Secure three-point locking system, raised cabinet base and integrated levelers. Manufacturer's limited one-year warranty. Contains 19% post-consumer recycled content, 25% total recycled content.

ID No.	Color	W x D x H	Shpg. Wt.	Unit	Price
<b>48w x 24d Cabinet</b>					
16	TNN-J2478SUBK	Black	48" x 24" x 78"	217 lbs.	Each <del>980.00</del>
17	TNN-J2478SULGY	Light Gray	48" x 24" x 78"	217 lbs.	Each <del>980.00</del>
18	TNN-J2478SUPY	Putty	48" x 24" x 78"	217 lbs.	Each <del>980.00</del>
<b>48w x 18d Cabinet</b>					
19	TNN-J1878SUBK	Black	48" x 18" x 78"	188 lbs.	Each <del>910.00</del>
20	TNN-J1878SULGY	Light Gray	48" x 18" x 78"	188 lbs.	Each <del>910.00</del>
21	TNN-J1878SUPY	Putty	48" x 18" x 78"	188 lbs.	Each <del>910.00</del>







Black (BK)



Light Gray (LGY)



Black (BK)



Light Gray (LGY)



## Storage Cabinets

### A JANITORIAL CABINET

All-welded steel construction with pan-style bottom. Three half-shelves plus extra-tall storage space for brooms, vacuums and more. Reinforced door stiffeners. Locking handle with keys for security. Manufacturer's one-year warranty. Contains 30% pre-consumer recycled content, 20% post-consumer recycled content, 50% total recycled content.

ID No.	Color	W × D × H	Shpg. Wt.	Unit	Price
1 TNN-JAN6618DHBK	Black	36" × 18" × 64"	104 lbs.	Each	<del>569.00</del>
2 TNN-JAN6618DHPY	Putty	36" × 18" × 64"	104 lbs.	Each	<del>569.00</del>

### B - C 72" HIGH STANDARD CABINET

Single handle. Four adjustable 36" wide shelves. Contains 19% post-consumer recycled content, 25% total recycled content.

ID No.	Color	W × D × H	Shpg. Wt.	Unit	Price
--------	-------	-----------	-----------	------	-------

**B 36W × 24D CABINET**—200 lb. weight capacity per shelf.

3 TNN-1480BK	Black	36" × 24" × 72"	135 lbs.	Each	<del>534.00</del>
4 TNN-1480LGY	Light Gray	36" × 24" × 72"	135 lbs.	Each	<del>534.00</del>
5 TNN-1480PY	Putty	36" × 24" × 72"	135 lbs.	Each	<del>534.00</del>

**C 36W × 18D CABINET**—150 lb. weight capacity per shelf.

6 TNN-1470BK	Black	36" × 18" × 72"	102 lbs.	Each	<del>465.00</del>
7 TNN-1470LGY	Light Gray	36" × 18" × 72"	102 lbs.	Each	<del>465.00</del>
8 TNN-1470PY	Putty	36" × 18" × 72"	120 lbs.	Each	<del>465.00</del>

### D 78" HIGH DELUXE CABINET

Four adjustable 36" wide shelves. Ventilating louvers on back. Double handles with three-point locking system. Adjustable leveling glides. Contains 19% post-consumer recycled content, 25% total recycled content.

ID No.	Color	W × D × H	Shpg. Wt.	Unit	Price
--------	-------	-----------	-----------	------	-------

**36w × 24d Cabinet**—200 lb. weight capacity per shelf.

9 TNN-2470BK	Black	36" × 24" × 78"	183 lbs.	Each	<del>654.00</del>
10 TNN-2470LGY	Light Gray	36" × 24" × 78"	183 lbs.	Each	<del>654.00</del>
11 TNN-2470PY	Putty	36" × 24" × 78"	183 lbs.	Each	<del>654.00</del>

**36w × 18d Cabinet**—150 lb. weight capacity per shelf.

12 TNN-1870BK	Black	36" × 18" × 78"	154 lbs.	Each	<del>596.00</del>
13 TNN-1870LGY	Light Gray	36" × 18" × 78"	154 lbs.	Each	<del>596.00</del>
14 TNN-1870PY	Putty	36" × 18" × 78"	154 lbs.	Each	<del>596.00</del>

Prices subject to change without notice.

Visit our website for the latest pricing and product information.



Five-shelf configuration provides maximum storage space.

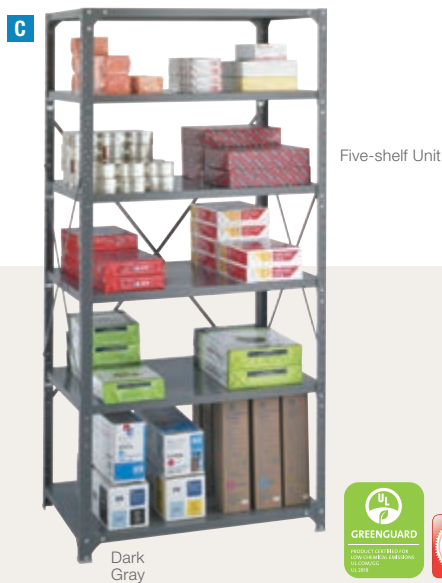

## Industrial & Commercial Steel Shelving

Adjustable shelf heights.

### A 75" HIGH COMMERCIAL STEEL SHELVING

Shelves adjust in 1" increments with compression clips. 250-lb. capacity per shelf (based on 36" x 12" shelf evenly distributed). Manufacturer's one-year warranty. Contains 30% pre-consumer recycled content, 25% post-consumer recycled content, 55% total recycled content. SCS Indoor Advantage Gold Certified.

ID No.	Color	W x D x H	Shpg. Wt.	Unit	Price
--------	-------	-----------	-----------	------	-------

#### Five Shelves with Closed Sides and Back

1	TNN-ESPC2436MGY	Medium Gray	36" x 24" x 75"	112 lbs.	Each	<del>305.00</del>
2	TNN-ESPC1836MGY	Medium Gray	36" x 18" x 75"	94 lbs.	Each	<del>331.00</del>
3	TNN-ESPC1236MGY	Medium Gray	36" x 12" x 75"	72 lbs.	Each	<del>344.00</del>

#### Six Shelves with Closed Sides and Back

4	TNN-ESPC62436MGY	Medium Gray	36" x 24" x 75"	121 lbs.	Each	<del>415.00</del>
5	TNN-ESPC61836MGY	Medium Gray	36" x 18" x 75"	102 lbs.	Each	<del>355.00</del>
6	TNN-ESPC61236MGY	Medium Gray	36" x 12" x 75"	78 lbs.	Each	<del>329.00</del>

### B STUR-D-STOR SHELVING

Boltless design lets you easily configure shelving into a five-shelf unit or a three-shelf/two-shelf worktable. Industrial-grade particle board shelves with steel frame. Each shelf holds up to 1,000 lbs., adjusts in 1½" increments. Contains 19% post-consumer recycled content, 25% total recycled content. Meets or exceeds ANSI/BIFMA Standards; SCS Indoor Advantage Gold Certified.

ID No.	Color	W x D x H	Shpg. Wt.	Unit	Price
--------	-------	-----------	-----------	------	-------

#### Five Shelves

7	TNN-LSS482484	Sand	48" x 24" x 84"	142 lbs.	Each	<del>302.00</del>
8	TNN-LSS361872	Sand	36" x 18" x 72"	88 lbs.	Each	<del>222.00</del>



## Heavy-Duty Industrial & Commercial Steel Shelving

Durable box beam design.

- Powder-coated finish.
- Shelves lock in place but can be easily repositioned in 1" increments.
- Manufacturer's limited lifetime warranty.
- GREENGUARD Certified; Meets or Exceeds ANSI/BIFMA Standards.

### C HEAVY-DUTY COMMERCIAL STEEL SHELVING UNIT

Double-sided compression clips support loads up to 750 lbs. per shelf (evenly distributed). Post kits included with each shelf pack.

ID No.	Color	W x D x H	Shpg. Wt.	Unit	Price
--------	-------	-----------	-----------	------	-------

#### Five Shelves

9	SAF-6267	Dark Gray	36" x 24" x 75"	73 lbs.	Each	<del>272.00</del>
10	SAF-6266	Dark Gray	36" x 18" x 75"	65 lbs.	Each	<del>223.00</del>
11	SAF-6265	Dark Gray	36" x 12" x 75"	55 lbs.	Each	<del>207.00</del>

#### Six Shelves

12	SAF-6270	Dark Gray	36" x 24" x 75"	82 lbs.	Each	<del>302.00</del>
13	SAF-6269	Dark Gray	36" x 18" x 75"	72 lbs.	Each	<del>272.00</del>
14	SAF-6268	Dark Gray	36" x 12" x 75"	60 lbs.	Each	<del>223.00</del>





Shelves and steel pack sold and shipped separately.



## Archival & Boltless Steel Shelving

- Shelves adjust in 1" increments for storage flexibility.
- Manufacturer's limited lifetime warranty.
- GREENGUARD Certified.

### A - B ARCHIVAL SHELVING

Shelves and Steel Pack sold and shipped separately—Both are required for assembly—ORDER BOTH. Offers trouble-free storage and retrieval of inactive files. Heavy-gauge, powder-coated gray steel frame easily locks together without tools. Warp-free particleboard shelves provide maximum strength to support up to 900 lbs. each (evenly distributed). Designed to hold up to 80 letter/legal archival storage boxes (12w x 15d x 10h), sold separately.

ID No.	Color	W x D x H	Shpg. Wt.	Unit	Price
<b>A PARTICLEBOARD SHELVES</b>					
1	SAF-5261	Gray	69" x 33" x 2"	117 lbs.	Box <del>398.00</del>
<b>B STEEL PACK</b>					
2	SAF-5260	Gray	69" x 33" x 84"	105 lbs.	Each <del>398.00</del>

### C - D BOLTLESS SHELVING

Unique boltless construction assembles in minutes and can be configured as a five-shelf, 72" high storage unit, or as a 36" high workbench. Steel frame with a durable powder coat finish.

ID No.	Color	W x D x H	Shpg. Wt.	Unit	Price
<b>C PARTICLEBOARD SHELVES</b>					
3	SAF-6244BL	Black	48" x 24" x 72"	109 lbs.	Each <del>361.00</del>
4	SAF-6246BL	Black	48" x 18" x 72"	108 lbs.	Each <del>324.00</del>
5	SAF-6247BL	Black	36" x 24" x 72"	92 lbs.	Each <del>307.00</del>
6	SAF-6245BL	Black	36" x 18" x 72"	75 lbs.	Each <del>277.00</del>
<b>D STEEL SHELVES</b>					
7	SAF-5244BL	Black	48" x 24" x 72"	89 lbs.	Each <del>349.00</del>
8	SAF-5246BL	Black	48" x 18" x 72"	76 lbs.	Each <del>297.00</del>
9	SAF-5247BL	Black	36" x 24" x 72"	89 lbs.	Each <del>291.00</del>
10	SAF-5245BL	Black	36" x 18" x 72"	61 lbs.	Each <del>249.00</del>

- \* SAF-6244BL, SAF-5246BL, SAF-5247BL—Holds up to 750 lbs. per shelf (evenly distributed).
- SAF-6246BL, SAF-6247BL, SAF-5245BL—Holds up to 850 lbs. per shelf (evenly distributed).
- SAF-6245BL—Holds up to 950 lbs. per shelf (evenly distributed).
- SAF-5244BL—Holds up to 650 lbs. per shelf (evenly distributed).

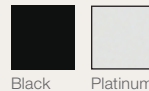

### E - G OFFICEWORKS™ STORAGE CABINET

Durable, commercial-grade cabinets. Dent- and scratch-resistant blow-molded high-density polyethylene with double walls. Easy to clean and resistant to cleaning chemicals. Recessed handles. Key lock. Easy assembly—minimal tools. Manufacturer's limited 15-year warranty. Contains 35% total recycled content.

ID No.	Color	W x D x H	Shpg. Wt.	Unit	Price
<b>E 72" HIGH CABINET</b> —Four shelves, three adjustable. 125-lb. capacity per shelf. 27½ cu. ft.					
11	ICE-92571	Black	36" x 22" x 72"	105 lbs.	Each <del>598.95</del>
12	ICE-92573	Platinum	36" x 22" x 72"	105 lbs.	Each <del>598.95</del>
<b>F 66" HIGH CABINET</b> —Three shelves, two adjustable. 75-lb. capacity per shelf. 18% cu. ft.					
13	ICE-92551	Black	33" x 18" x 66"	84 lbs.	Each <del>513.95</del>
14	ICE-92553	Platinum	33" x 18" x 66"	84 lbs.	Each <del>513.95</del>
<b>G 46" HIGH CABINET</b> —Two shelves, one adjustable. 125-lb. capacity per shelf. 17% cu. ft.					
15	ICE-92561	Black	36" x 22" x 46"	68 lbs.	Each <del>459.95</del>
16	ICE-92563	Platinum	36" x 22" x 46"	68 lbs.	Each <del>459.95</del>

### H - I ROUGH N READY™ OPEN STORAGE SYSTEM

Manufacturer's 15-year limited warranty. Contains 35% total recycled content.

ID No.	Color	W x D x H	Shpg. Wt.	Unit	Price
<b>H FOUR SHELVES</b> —Constructed of injection molded polypropylene. 15" clearance between shelves. 75-lb. capacity per shelf evenly distributed.					
17	ICE-20841	Black	32" x 13" x 54"	18 lbs.	Each <del>137.95</del>
18	ICE-20843	Platinum	32" x 13" x 54"	18 lbs.	Each <del>137.95</del>
<b>I FIVE SHELVES</b> —Constructed of blow-molded high-density polyethylene. 16" clearance between shelves. 180-lb. capacity per shelf evenly distributed.					
19	ICE-20851	Black	36" x 18" x 74"	45 lbs.	Each <del>299.95</del>
20	ICE-20853	Platinum	36" x 18" x 74"	45 lbs.	Each <del>299.95</del>

Prices subject to change without notice. Visit our website for the latest pricing and product information.

## Quick Comparison Chart

Consider what you'll be storing, how often you need to access the stored items and where the shelving will be placed.





Type	Heavy Duty Industrial	Medium Duty Commercial	Light Duty Residential
Weight Capacity per Shelf	Up to 1200 lbs.	Up to 600 lbs.	Up to 300 lbs.
Access Frequency	High	Medium	Low
Finish Durability	NSF Wet/Dry Environment or Dry Environment	NSF Dry Environment	NSF Dry Environment
Shelf Width(s)	36", 48", 60" and 72"	48"	36"
Shelf Depth(s)	18" and 24"	18"	14"
Half-Height Kit Included	Yes	No	No
Warranty/Corrosion	5-year/8-year limited	5-year limited	5-year limited

### For Alera Wire Shelving



## Heavy-Duty Industrial Wire Shelving

Find your ideal storage solution for industrial, foodservice, medical industry and all other storage needs.

- Reinforced extra-strong welded wire construction provides unmatched strength and stability.
- Open design that allows for air circulation. Shelves adjust in 1" increments.
- Can be set up as a four-tier single rack or as two two-tier racks to meet specific needs.
- Manufacturer's limited five-year product warranty, eight-year corrosion-free guarantee.  

### A BLACK ANTHRACITE PLUS WIRE SHELVING KIT

Universal storage solution ideal for industrial, foodservice and medical and all other storage needs. Long-lasting industrial-grade finish resists corrosion in even the harshest environment, wet or dry. Heavy-duty shelves withstand constant re-stocking. Can be used in freezer applications and with an open design that allows for air circulation. Snap-together design assembles in minutes without tools. Can be set up as a four-tier single rack or as two two-tier racks to meet specific needs. NSF certified for wet and dry usage.

ID No.	Color	W x D x H	Shpg. Wt.	Unit	Price
<b>24" DEEP, 4 SHELF</b> —Up to 1,000 lbs. per shelf (evenly distributed).					
1	ALE-SW207224BA	Black Anthracite Plus	72" x 24" x 72"	117 lbs.	Each <del>795.00</del>
2	ALE-SW206024BA	Black Anthracite Plus	60" x 24" x 72"	103 lbs.	Each <del>565.00</del>
<b>18" DEEP, 4 SHELF KIT</b> —Up to 1,000 lbs. per shelf (evenly distributed).					
3	ALE-SW207218BA	Black Anthracite Plus	72" x 18" x 72"	96 lbs.	Each <del>565.00</del>
4	ALE-SW206018BA	Black Anthracite Plus	60" x 18" x 72"	86 lbs.	Each <del>409.00</del>

### B BLACK ANTHRACITE WIRE SHELVING KIT

Ideal storage solution for commercial and restaurant use. Black Anthracite finish is National Sanitation Foundation (NSF) certified for wet and dry environments. Includes four shelves, eight 36" posts, floor leveling glides and conversion kit to convert to two half-height two-shelf units. Shelves adjust in 1" increments.

ID No.	Color	W x D x H	Shpg. Wt.	Unit	Price
<b>24" DEEP, 4 SHELF</b> —Up to 1,000 lbs. per shelf (evenly distributed).					
5	ALE-SW50-4824BA	Black Anthracite	48" x 24" x 72"	80 lbs.	Each <del>500.00</del>
6	ALE-SW50-3624BA	Black Anthracite	36" x 24" x 72"	65 lbs.	Each <del>495.00</del>
<b>18" DEEP, 4 SHELF KIT</b> —Up to 1,250 lbs. per shelf (evenly distributed).					
7	ALE-SW50-4818BA	Black Anthracite	48" x 18" x 72"	72 lbs.	Each <del>460.00</del>
8	ALE-SW50-3618BA	Black Anthracite	36" x 18" x 72"	60 lbs.	Each <del>405.00</del>





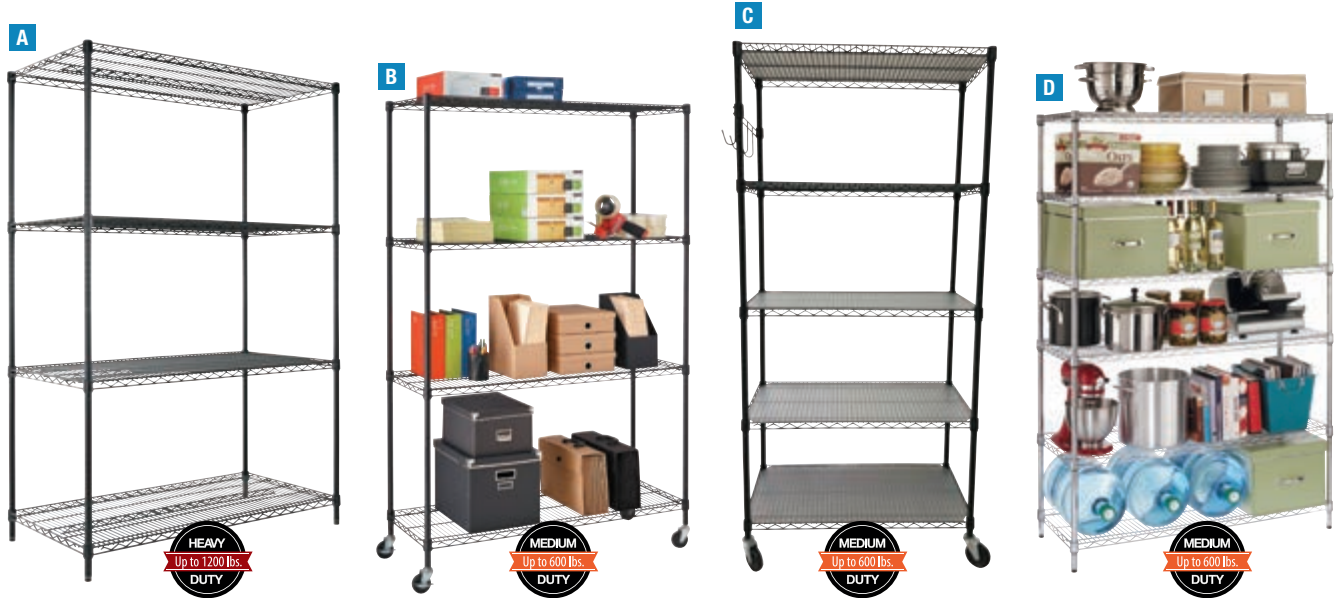

## Heavy-Duty Industrial Wire Shelving



Find your ideal storage solution for industrial, foodservice, medical industry and all other storage needs.

- Reinforced extra-strong welded wire construction provides unmatched strength and stability.
- Open design that allows for air circulation.
- Shelves adjust in 1" increments.
- Can be set up as a four-tier single rack or as two two-tier racks to meet specific needs.
- Manufacturer's limited five-year warranty.

### A WIRE SHELVING STARTER KIT

Strong welded wire construction storage units. Includes four shelves, eight 36" posts, shelf clips, feet leveling glides and conversion kit to create two half height (36"h) two-shelf storage units. NSF certified for dry environment usage.

ID No.	Color	W x D x H	Shpg. Wt.	Unit	Price
<b>24" DEEP</b> —Up to 1,000 lbs. per shelf (evenly distributed).					
1	ALE-SW50-4824BL	Black 48" x 24" x 72"	80 lbs.	Each	<del>500.00</del>
2	ALE-SW50-4824SR	Silver 48" x 24" x 72"	80 lbs.	Each	<del>500.00</del>
3	ALE-SW50-3624BL	Black 36" x 24" x 72"	65 lbs.	Each	<del>435.00</del>
4	ALE-SW50-3624SR	Silver 36" x 24" x 72"	65 lbs.	Each	<del>435.00</del>
<b>18" DEEP</b> —Up to 1,250 lbs. per shelf (evenly distributed).					
5	ALE-SW50-4818BL	Black 48" x 18" x 72"	72 lbs.	Each	<del>460.00</del>
6	ALE-SW50-4818SR	Silver 48" x 18" x 72"	72 lbs.	Each	<del>460.00</del>
7	ALE-SW50-3618BL	Black 36" x 18" x 72"	60 lbs.	Each	<del>405.00</del>
8	ALE-SW50-3618SR	Silver 36" x 18" x 72"	60 lbs.	Each	<del>405.00</del>

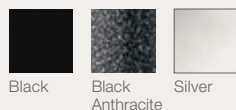

## Medium-Duty Commercial Wire Shelving



The perfect solution for all your storage needs.

- NSF certified for wet/dry (Black Anthracite) or dry only environments.
- Open design allows air circulation and reduces dust build-up.
- Strong welded wire construction provides exceptional strength and stability.
- Manufacturer's limited five-year warranty.

### B 4-SHELF WIRE SHELVING KIT WITH CASTERS

Sturdy and solid shelving for business or restaurant environments. Includes four shelves, posts, shelf clips, leveling glides, and four 3" casters (two locking).

ID No.	Color	W x D x H	Shpg. Wt.	Unit	Price
<b>18" DEEP</b> —Up to 600 lbs. per shelf (evenly distributed) when used without casters.					
9	ALE-SW604818BL	Black 48" x 18" x 72"	55 lbs.	Each	<del>345.00</del>
10	ALE-SW604818BA	Black Anthracite 48" x 18" x 72"	55 lbs.	Each	<del>345.00</del>
11	ALE-SW604818SR	Silver 48" x 18" x 72"	52 lbs.	Each	<del>345.00</del>

*\* Use of casters may reduce total weight capacity.*

### C 5-SHELF WIRE SHELVING KIT WITH CASTERS AND SHELF LINERS

Open, snap-together design. Strong welded wire construction. Includes five shelves, posts, shelf liners, casters, hooks and level glides (if used without casters). Ideal for business, commercial or food service establishments.

ID No.	Color	W x D x H	Shpg. Wt.	Unit	Price
<b>18" DEEP</b> —Up to 600 lbs. per shelf (evenly distributed) when used without casters.					
12	ALE-SW654818BA	Black Anthracite 48" x 18" x 72"	66 lbs.	Each	<del>355.00</del>
13	ALE-SW654818SR	Silver 48" x 18" x 72"	66 lbs.	Each	<del>355.00</del>
14	ALE-SW653618BA	Black Anthracite 36" x 18" x 72"	57 lbs.	Each	<del>345.00</del>
15	ALE-SW653618SR	Silver 36" x 18" x 72"	53 lbs.	Each	<del>345.00</del>

*\* Use of casters may reduce total weight capacity.*

### D 6-SHELF WIRE SHELVING KIT

Ideal storage solution for commercial or business use. Includes six shelves, posts, shelf clips and leveling glides.

ID No.	Color	W x D x H	Shpg. Wt.	Unit	Price
<b>18" DEEP</b> —Up to 600 lbs. per shelf (evenly distributed).					
16	ALE-SW664818BL	Black 48" x 18" x 72"	70 lbs.	Each	<del>355.00</del>
17	ALE-SW664818BA	Black Anthracite 48" x 18" x 72"	70 lbs.	Each	<del>355.00</del>
18	ALE-SW664818SR	Silver 48" x 18" x 72"	70 lbs.	Each	<del>355.00</del>

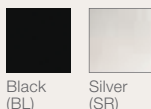

## Wire Shelves

Add extra shelves to existing units, build your own customized unit, or add on shelf extensions and convenient storage accessories with these shelves.

- Strong welded wire construction provides exceptional strength and stability.
- Open design allows air circulation and helps reduce dust build-up.
- Snap-together design assembles in minutes.
- 2 shelves per carton.
- Manufacturer's limited five-year warranty.

### A INDUSTRIAL WIRE SHELVING EXTRA WIRE SHELVES

ID No.	Color	W x D	Shpg. Wt.	Qty.	Unit	Price
<b>24" DEEP</b> —Up to 1,000 lbs. per shelf (evenly distributed).						
1	ALE-SW58-4824BL	Black	48" x 24"	35 lbs.	2 Carton	<del>225.00</del>
2	ALE-SW58-3624BL	Black	36" x 24"	27 lbs.	2 Carton	<del>199.00</del>
3	ALE-SW58-4824SR	Silver	48" x 24"	35 lbs.	2 Carton	<del>225.00</del>
4	ALE-SW58-3624SR	Silver	36" x 24"	28 lbs.	2 Carton	<del>199.00</del>
<b>18" DEEP</b> —Up to 1,250 lbs. per shelf (evenly distributed).						
5	ALE-SW58-4818BL	Black	48" x 18"	31 lbs.	2 Carton	<del>199.00</del>
6	ALE-SW58-3618BL	Black	36" x 18"	24 lbs.	2 Carton	<del>161.00</del>
7	ALE-SW58-4818SR	Silver	48" x 18"	31 lbs.	2 Carton	<del>199.00</del>
8	ALE-SW58-3618SR	Silver	36" x 18"	24 lbs.	2 Carton	<del>161.00</del>

### B STACKABLE POSTS

Add-on poles allow you to easily add on shelves or create custom sized units (combined with Extra Shelves and Shelf Connecting Hooks). Includes levelers for uneven floors and four 36" posts—combine two posts for 72" shelving. Manufacturer's limited five-year warranty.

ID No.	Color	Size	Qty.	Unit	Price
<b>Stackable Posts</b>					
9	ALE-SW59-P036BL	Black	36"	4 Pack	<del>75.00</del>
10	ALE-SW59-P036SR	Silver	36"	4 Pack	<del>73.00</del>



### C - H ALSO CONSIDER:

ID	No.	Description	Qty.	Unit	Price
11	<b>C</b> ALE-SW59ST	Shelf Tags, Gray, 3" Wide	10	Pack	<del>11.00</del>
12	<b>D</b> ALE-SW59SHBL	Shelf Connecting Hooks, Black	4	Pack	<del>12.00</del>
13	ALE-SW59SHSR	Shelf Connecting Hooks, Silver	4	Pack	<del>12.00</del>
14	<b>E</b> ALE-SW59SLBL	Shelf Lock Clips, Black	4	Pack	<del>7.50</del>
15	<b>F</b> ALE-SW59SL4824	Shelf Liner, 48 x 24, Clear	4	Pack	<del>145.00</del>
16	ALE-SW59SL4818	Shelf Liner, 48 x 18, Clear	4	Pack	<del>120.00</del>
17	ALE-SW59SL3624	Shelf Liner, 36 x 24, Clear	4	Pack	<del>120.00</del>
18	ALE-SW59SL3618	Shelf Liner, 36 x 18, Clear	4	Pack	<del>80.00</del>
19	ALE-SW59HB424SR	Five Hook Bar, 24" Deep, Silver	2	Pack	<del>52.00</del>
20	<b>G</b> ALE-SW59HB418SR	Four Hook Bar, 18" Deep, Silver	2	Pack	<del>40.00</del>
21	ALE-SW690004	4" casters, 2 locking	4	Set	<del>120.00</del>
22	ALE-SW790004	3" casters, 2 locking	4	Set	<del>103.00</del>
23	<b>H</b> ALE-SW59-0004	5" Casters with Bumpers, 2 Locking	4	Set	<del>137.00</del>

Customize and reconfigure your shelving for ideal storage with add-on components.



**Shelf Tags**  
Snaps on; includes paper labels.



**Shelf Connecting Hooks**  
Use to secure additional shelves together.



**Shelf Lock Clips**



**Shelf Liners**  
Prevents small items from falling through.

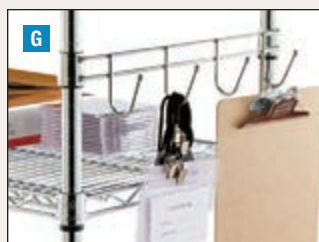

**Hook Bars**



**Casters**  
Add optional casters to create a fully mobile solution



**A**



**B**

Silver Steel

Black Steel



**C**

Black



**D**

Silver



**F**

Black Anthracite



**E**

Silver



Black

Black Anthracite

Silver

## ALERA. Light-Duty Residential Wire Shelving



### A RESIDENTIAL WIRE SHELVING

An economical storage solution for light-duty applications. Snap-together design assembles in minutes. Strong welded wire construction provides exceptional strength and stability. Open design allows air circulation and reduces dust build-up. Up to 250 lbs. per shelf (evenly distributed). Meets or exceeds ANSI/BIFMA Standards. Use of casters (optional) may reduce total weight capacity.

ID No.	Color	W × D × H	Shpg. Wt.	Unit	Price
<b>5 SHELF KIT</b>					
1	ALE-SW853614SR	Silver	36" × 14" × 72"	37 lbs.	Each <del>225.00</del>
<b>4 SHELF KIT</b>					
2	ALE-SW843614SR	Silver	36" × 14" × 54"	30 lbs.	Each <del>175.00</del>
<b>3 SHELF KIT</b>					
3	ALE-SW833614SR	Silver	36" × 14" × 36"	22 lbs.	Each <del>149.00</del>

### B WIRE SHELVING GARMENT RACK

Time-saving design assembles in minutes without tools. Strong welded wire construction. Double-sided for quick access to items. Rack features four ft. hanging rod for garments, five support hooks. Three shelves adjust in 1" increments and support 350 lbs. on each shelf. Four casters for quick mobility and two lock. Total unit capacity is 500 lbs. if used with casters. Hangers not included. Manufacturer's limited five-year warranty.

ID No.	Finish	W × D × H	Unit	Price
4	ALE-GR364818BL	Black Steel	48" × 18" × 75"	Each <del>391.00</del>
5	ALE-GR364818SR	Silver Steel	48" × 18" × 75"	Each <del>391.00</del>
6	ALE-GR363618BL	Black Steel	36" × 18" × 75"	Each <del>309.00</del>
7	ALE-GR363618SR	Silver Steel	36" × 18" × 75"	Each <del>309.00</del>

### C ROLLING FILE CART

Accommodates letter and legal size hanging files. Versatile front to back or side to side filing. Can be assembled with no tools in about 60 seconds. Lower shelf supports up to 150 lbs. Casters (to locking) for mobility.

ID No.	Finish	W × D × H	Shpg. Wt.	Unit	Price
<b>Two-Tier File Unit</b> —Front-to-back and side-to-side filing.					
8	ALE-FW60-1426BL	Black	26" × 14" × 29½"	17 lbs.	Each <del>197.00</del>
<b>Single-Tier File Unit</b> —Side-to-side filing only.					
9	ALE-FW60-1424BL	Black	24" × 14" × 21"	12 lbs.	Each <del>103.00</del>
<b>Compact Single-Tier File Unit</b> —Front-to-back and side-to-side filing.					
10	ALE-FW60-1416BL	Black	12¾" × 15¼" × 21"	9 lbs.	Each <del>158.00</del>

### D CARRY-ALL CART/MAIL CART

7" deep top basket can accommodate letter- or legal-size files with included adjustable file rods. Sturdy bottom basket with 4" raised sides. Heavy-duty metal tube and wire construction resists scratches and withstands constant use. Snaps together in minutes without tools. Shelf and basket height adjustable in 1" increments. Manufacturer's limited five-year warranty.

ID No.	Finish	W × D × H	Shpg. Wt.	Unit	Price
11	ALE-MC3518SR	Silver	34¾" × 18" × 39½"	29 lbs.	Each <del>369.00</del>

### E 3-SHELF WIRE CART WITH LINERS

Three adjustable shelves with pull handle. Includes three shelf liners and four casters (two locking). Easy to assemble—no tools required. Shelves adjust in 1" increments. 500 lbs. total weight capacity. Manufacturer's limited five-year warranty.

ID No.	Finish	W × D × H	Shpg. Wt.	Unit	Price
<b>Four 4" Casters</b>					
12	ALE-SW333018SR	Silver	34½" × 18" × 40"	27 lbs.	Each <del>249.00</del>
<b>Four 3" Casters</b>					
13	ALE-SW322416SR	Silver	28½" × 16" × 39"	24 lbs.	Each <del>161.00</del>

### F THREE-TIER WIRE SHELVING ROLLING CART WITH BASKET

Sturdy and solid wire cart for mobile shelving needs. Includes two wire shelves, one wire basket with one pull handle and four casters (two locking). Black Anthracite finish for wet and dry usages. Easy to assemble—no tools required. Shelves and baskets adjust in 1" increments. 500 lbs. total weight capacity. Manufacturer's limited five-year warranty.

ID No.	Finish	W × D × H	Shpg. Wt.	Unit	Price
<b>Four 4" Casters</b> —Includes three shelf liners.					
14	ALE-SW543018BA	Black Anthracite	34" × 18" × 40"	41 lbs.	Each <del>279.00</del>
<b>Four 3" Casters</b>					
15	ALE-SW342416BA	Black Anthracite	28" × 16" × 39"	26 lbs.	Each <del>179.00</del>

Prices subject to change without notice. Visit our website for the latest pricing and product information.



# Storage Lockers



Medium Gray (MG)



Medium Gray (MG)



Sand (SD)

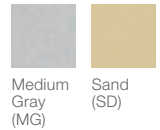

Medium Gray (MG)



Medium Gray (MG)



## Steel Lockers

Ideal for school, industrial, medical or office settings.

- Heavy-gauge steel with powder coated finish and tamperproof hinges.
- Vertical louvers for ventilation.
- Full-length door stiffeners add rigidity and deaden sound when opening/closing.
- Padlock hasps and number plates.
- Multiple rows of lockers can be ganged with standard nuts and bolts (not included).
- Manufacturer's limited one-year warranty.
- Contains 45% post-consumer recycled content, 85% total recycled content.
- SCS Indoor Advantage Gold Certified.

### A SINGLE TIER LOCKER

Each compartment: 12w × 18d × 72h with hat shelf and coat rod. Recessed black metal handles. Three-point locking system provides security.

ID No.	Color	W × D × H	Shpg. Wt.	Unit	Price
<b>Three Lockers with Legs</b>					
1	TNN-ST51218723MG	Medium Gray	36" × 18" × 78"	173 lbs.	Each <del>1,006.00</del>
2	TNN-ST51218723SD	Sand	36" × 18" × 78"	173 lbs.	Each <del>1,006.00</del>
<b>Individual Lockers with Legs</b>					
3	TNN-ST51218721MG	Medium Gray	12" × 18" × 78"	70 lbs.	Each <del>436.00</del>
4	TNN-ST51218721SD	Sand	12" × 18" × 78"	70 lbs.	Each <del>436.00</del>

### B DOUBLE TIER LOCKER

Each compartment: 12w × 18d × 36h with coat hook. Recessed black metal handles. Two-point locking system provides security. Overall 72" high.

ID No.	Color	W × D × H	Shpg. Wt.	Unit	Price
<b>Triple Stack with Legs</b> —Six lockers with tamper-proof hinges and vertical louvers.					
5	TNN-DTS1218363MG	Medium Gray	36" × 18" × 78"	175 lbs.	Each <del>1,053.00</del>
6	TNN-DTS1218363SD	Sand	36" × 18" × 78"	175 lbs.	Each <del>1,053.00</del>
<b>Single Stack with Legs</b> —Two lockers with tamper-proof hinges and vertical louvers.					
7	TNN-DTS1218361MG	Medium Gray	12" × 18" × 78"	70 lbs.	Each <del>453.00</del>
8	TNN-DTS1218361SD	Sand	12" × 18" × 78"	70 lbs.	Each <del>453.00</del>

### C BOX COMPARTMENTS

Each compartment: 12w × 18d × 12h. Multiple rows of lockers can be ganged with standard nuts and bolts (not included).

ID No.	Color	W × D × H	Shpg. Wt.	Unit	Price
<b>Triple Stack with Legs</b> —18 compartment lockers.					
9	TNN-BS61218123MG	Medium Gray	36" × 18" × 78"	182 lbs.	Each <del>1,167.00</del>
10	TNN-BS61218123SD	Sand	36" × 18" × 78"	182 lbs.	Each <del>1,167.00</del>
<b>Single Stack with Legs</b> —Six compartment lockers.					
11	TNN-BS61218121MG	Medium Gray	12" × 18" × 78"	72 lbs.	Each <del>484.00</del>
12	TNN-BS61218121SD	Sand	12" × 18" × 78"	72 lbs.	Each <del>484.00</del>

## Steel Shop Desks

Heavy-gauge steel construction.

- Sloped top provides ergonomic comfort while standing and working.
- Compartmentalized riser keeps frequently used items close at hand.
- Locking drawer.
- Contains 19% post-consumer recycled content, 25% total recycled content.
- SCS Indoor Advantage Gold Certified.

### D STEEL CABINET SHOP DESK

Enclosed lower cabinet with two shelves and locking doors.

ID No.	Color	W × D × H	Shpg. Wt.	Unit	Price
13	TNN-SR58MG	Medium Gray	36" × 30" × 53¾"	155 lbs.	Each <del>942.00</del>

### E OPEN STEEL SHOP DESK

Bottom storage shelf/footrest.

ID No.	Color	W × D × H	Shpg. Wt.	Unit	Price
14	TNN-SR57MG	Medium Gray	34½" × 29" × 53¾"	97 lbs.	Each <del>591.00</del>





## Steel Lockers

Ideal for school, industrial, medical or office settings.

- Heavy-gauge steel with powder coated finish and tamperproof hinges.
- Vertical louvers for ventilation.
- Full-length door stiffeners add rigidity and deaden sound when opening/closing.
- Padlock hasps and number plates.
- Multiple rows of lockers can be ganged with standard nuts and bolts (not included).
- Manufacturer's limited one-year warranty.
- Contains 19% post-consumer recycled content, 25% total recycled content.
- SCS Indoor Advantage Gold Certified.

### A SINGLE TIER LOCKER

Each compartment: 12w x 18d x 72h with hat shelf and coat rod. Recessed black metal handles. Three-point locking system provides security.

ID No.	Color	W x D x H	Shpg. Wt.	Unit	Price
<b>Three Lockers</b> —Configure with optional base (sold separately) to raise locker 6" off floor for easier access to bottom unit.					
1	TNN-ST121872CMG Medium Gray	36" x 18" x 72"	190 lbs.	Each	<del>970.00</del>
2	TNN-ST121872CSD Sand	36" x 18" x 72"	190 lbs.	Each	<del>970.00</del>
<b>Individual Lockers</b> —Configure with optional base (sold separately) to raise locker 6" off floor for easier access to bottom unit.					
3	TNN-ST121872AMG Medium Gray	12" x 18" x 72"	76 lbs.	Each	<del>417.00</del>
4	TNN-ST121872ASD Sand	12" x 18" x 72"	76 lbs.	Each	<del>417.00</del>

### B DOUBLE TIER LOCKER

Each compartment: 12w x 18d x 36h with coat hook. Recessed black metal handles. Two-point locking system provides security. Overall 72" high.

ID No.	Color	W x D x H	Shpg. Wt.	Unit	Price
<b>Triple Stack</b> —Six lockers with tamper-proof hinges and vertical louvers. Configure with optional base (sold separately) to raise locker 6" off floor for easier access to bottom unit.					
5	TNN-DTS121836CMG Medium Gray	36" x 18" x 72"	175 lbs.	Each	<del>1,018.00</del>
6	TNN-DTS121836CSD Sand	36" x 18" x 72"	175 lbs.	Each	<del>1,018.00</del>
<b>Single Stack</b> —Two lockers with tamper-proof hinges and vertical louvers. Configure with optional base (sold separately) to raise locker 6" off floor for easier access to bottom unit.					
7	TNN-DTS121836AMG Medium Gray	12" x 18" x 72"	72 lbs.	Each	<del>433.00</del>
8	TNN-DTS121836ASD Sand	12" x 18" x 72"	72 lbs.	Each	<del>433.00</del>



### C BOX COMPARTMENTS

Each compartment: 12w x 18d x 12h. Multiple rows of lockers can be ganged with standard nuts and bolts (not included).

ID No.	Color	W x D x H	Shpg. Wt.	Unit	Price
<b>Triple Stack</b> —18 compartment lockers. Configure with optional locker base (Sold Separately).					
9	TNN-BS6121812CMG Medium Gray	36" x 18" x 72"	196 lbs.	Each	<del>1,148.00</del>
10	TNN-BS6121812CSD Sand	36" x 18" x 72"	196 lbs.	Each	<del>1,148.00</del>
<b>Single Stack</b> —Six compartment lockers. Configure with optional locker base (Sold Separately).					
11	TNN-BS6121812AMG Medium Gray	12" x 18" x 72"	77 lbs.	Each	<del>461.00</del>
12	TNN-BS6121812ASD Sand	12" x 18" x 72"	77 lbs.	Each	<del>461.00</del>

### D SIXTEEN BOX COMPARTMENTS AND COAT BAR

Space efficient design features two six-compartment vertical units, one four-compartment horizontal unit and 48" wide coat bar. Meets or Exceeds ANSI/BIFMA Standards

ID No.	Color	W x D x H	Shpg. Wt.	Unit	Price
13	TNN-SRS721872AMG Medium Gray	72" x 18" x 72"	189 lbs.	Each	<del>1,349.00</del>
14	TNN-SRS721872ASD Sand	72" x 18" x 72"	189 lbs.	Each	<del>1,349.00</del>

### E OPTIONAL LOCKER BASE

Raises lockers 6" off floor for easier access to bottom lockers. Provide protection from moisture.

ID No.	Color	Size	Shpg. Wt.	Qty.	Unit	Price
15	TNN-CLB-3618MG Medium Gray	36" x 18" x 6"	20 lbs.	1	Each	<del>88.00</del>
16	TNN-CLB-3618SD Sand	36" x 18" x 6"	20 lbs.	1	Each	<del>88.00</del>
17	TNN-CLB-1218MG Medium Gray	12" x 18" x 6"	8 lbs.	1	Each	<del>45.00</del>
18	TNN-CLB-1218SD Sand	12" x 18" x 6"	8 lbs.	1	Each	<del>45.00</del>



Prices subject to change without notice. Visit our website for the latest pricing and product information.

# Storage Lockers



## Steel Lockers

Contemporary two-tone units offer secure storage with style.

- Heavy gauge, all-steel construction and strong uni-body design stand up to tough conditions.
- Fully assembled units can be linked together for greater capacity.
- Raised 6" off the floor for easier access and perforated for ventilation.
- Manufacturer's limited lifetime warranty.
- GREENGUARD Certified.

### A - B SINGLE-TIER LOCKERS

Convenient storage with shelf, bar and double hook. Recessed handle with padlock provision has no protruding parts.

ID No.	Color	W x D x H	Shpg. Wt.	Unit	Price
<b>A THREE LOCKERS</b>					
1	SAF-5525GR	Two-Tone Gray	36" x 18" x 78"	180 lbs.	Each <del>999.00</del>
2	SAF-5525TN	Two-Tone Tan	36" x 18" x 78"	180 lbs.	Each <del>999.00</del>
<b>B INDIVIDUAL LOCKERS</b>					
3	SAF-5522GR	Two-Tone Gray	12" x 18" x 78"	71 lbs.	Each <del>399.00</del>
4	SAF-5522TN	Two-Tone Tan	12" x 18" x 78"	71 lbs.	Each <del>399.00</del>



### C - D DOUBLE-TIER LOCKERS

Convenient storage with double hook and bar. Recessed handle with padlock provision has no protruding parts.

ID No.	Color	W x D x H	Shpg. Wt.	Unit	Price
<b>C THREE LOCKERS</b>					
5	SAF-5526GR	Two-Tone Gray	36" x 18" x 78"	216 lbs.	Each <del>1,025.00</del>
6	SAF-5526TN	Two-Tone Tan	36" x 18" x 78"	216 lbs.	Each <del>1,025.00</del>
<b>D INDIVIDUAL LOCKERS</b>					
7	SAF-5523GR	Two-Tone Gray	12" x 18" x 78"	71 lbs.	Each <del>449.00</del>
8	SAF-5523TN	Two-Tone Tan	12" x 18" x 78"	71 lbs.	Each <del>449.00</del>

### E - F BOX LOCKERS

Padlock clasp for security.

ID No.	Color	W x D x H	Shpg. Wt.	Unit	Price
<b>E THREE LOCKERS</b>					
9	SAF-5527GR	Two-Tone Gray	36" x 18" x 78"	243 lbs.	Each <del>1,115.00</del>
10	SAF-5527TN	Two-Tone Tan	36" x 18" x 78"	243 lbs.	Each <del>1,115.00</del>
<b>F INDIVIDUAL LOCKERS</b>					
11	SAF-5524GR	Two-Tone Gray	12" x 18" x 78"	78 lbs.	Each <del>443.00</del>
12	SAF-5524TN	Two-Tone Tan	12" x 18" x 78"	78 lbs.	Each <del>443.00</del>

# Tables

Transform any area into a flexible gathering space.



**One of the most versatile pieces**, a table can turn a corner into a flexible gathering space, an empty room into a training center, a café into a collaboration zone. Adaptable designs that roll, fold or adjust up and down take flexibility to the next level so you can rearrange, customize and store tables away. Welcome to the endless possibilities our wide selection of tables brings.

Occasional	202
Conference	203-204
Training	205-211
Utility and Folding	212-217
Hospitality	218-219
Indoor/Outdoor & Picnic	220-222

# Tables Occasional

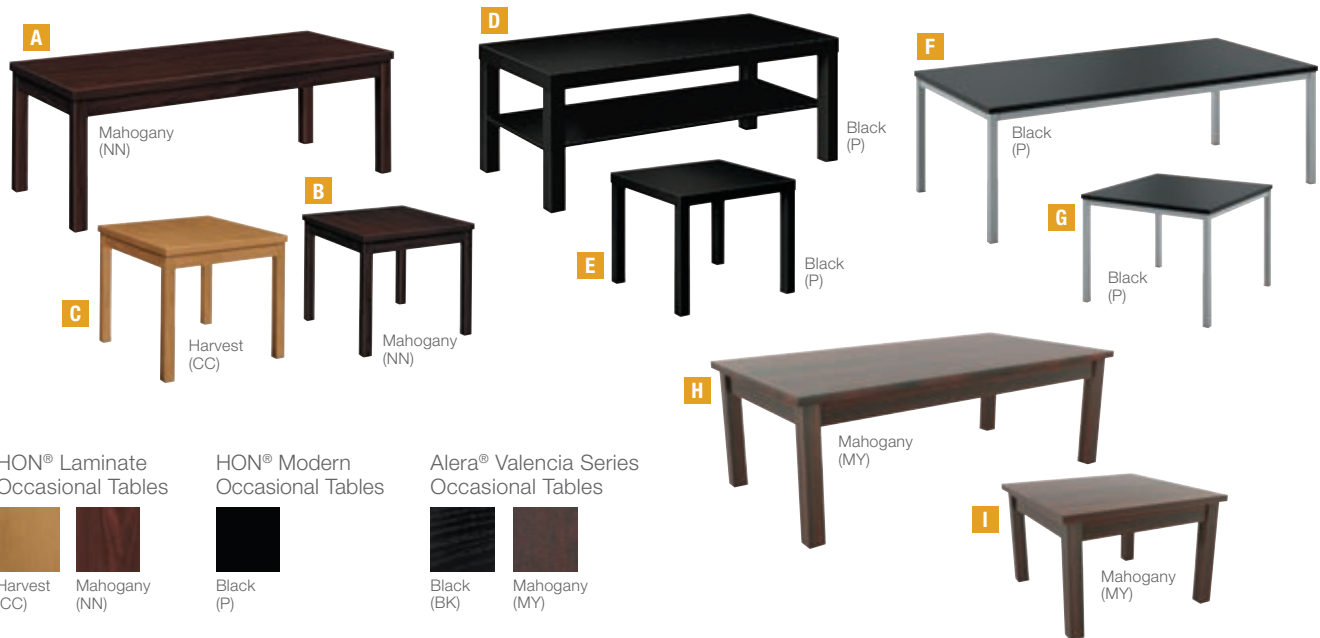

HON® Laminat Occasional Tables



HON® Modern Occasional Tables

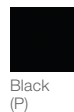

Alera® Valencia Series Occasional Tables

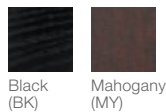

**HON.**



## Laminat Occasional Tables

**Sleek, classic styling that's durable.**

- Ideal for high traffic areas such as reception areas, lounges and offices.
- Scratch-, spill- and stain-resistant laminate stands up to heavy use.
- Solid wood legs are easy to attach.
- Backed by the HON Full Lifetime Warranty.
- Contains 70% pre-consumer recycled content, 3% post-consumer recycled content.
- Level 2 Certified; Meets or Exceeds ANSI/BIFMA Standards; SCS Indoor Advantage Certified.

ID No.	Color	Size	Shpg. Wt.	Unit	Price
<b>A COFFEE TABLE</b>					
1	HON-80191CC	Harvest	48" × 20" × 16"	48 lbs.	Each <del>466.00</del>
2	HON-80191NN	Mahogany	48" × 20" × 16"	48 lbs.	Each <del>466.00</del>
<b>B CORNER TABLE</b>					
3	HON-80192CC	Harvest	24" × 24" × 20"	35 lbs.	Each <del>402.00</del>
4	HON-80192NN	Mahogany	24" × 24" × 20"	35 lbs.	Each <del>402.00</del>
<b>C END TABLE</b>					
5	HON-80193CC	Harvest	24" × 20" × 20"	29 lbs.	Each <del>384.00</del>
6	HON-80193NN	Mahogany	24" × 20" × 20"	29 lbs.	Each <del>384.00</del>

## Laminat Occasional Tables

**Ideal for reception areas, lounges and offices with sleek, contemporary styling that's lightweight yet durable.**

- Ideal for high traffic areas such as reception areas, lounges, and offices.
- Scratch-, spill-, and stain-resistant, thermal-fused laminate stands up to heavy use.
- Solid wood legs are easy to attach.
- Backed by the HON Full Lifetime Warranty.
- Contains 70% pre-consumer recycled content, 3% post-consumer recycled content.
- Level 2 Certified; Meets or exceeds ANSI/BIFMA Standards; SCS Indoor Advantage Certified.

ID No.	Color	Size	Shpg. Wt.	Unit	Price
<b>D COFFEE TABLE</b>					
7	BSX-BLH3160P	Black	42" × 20" × 16"	24 lbs.	Each <del>240.00</del>
<b>E CORNER TABLE</b>					
8	BSX-BLH3170P	Black	24" × 24" × 20"	9 lbs.	Each <del>199.00</del>

## Modern Occasional Tables

**Discover excellence without expense.**

- A contemporary addition to any lobby, waiting room or executive office.
- Platinum tubular steel frame stands up to frequent handling.
- Scratch-, spill- and stain-resistant laminate withstands heavy use.
- Backed by the HON Limited Five-Year Warranty.

ID No.	Color	Size	Shpg. Wt.	Unit	Price
<b>F COFFEE TABLE</b>					
9	BSX-HML8852P	Black	48" × 24" × 15½"	39 lbs.	Each <del>241.00</del>
<b>G CORNER TABLE</b>					
10	BSX-HML8851P	Black	24" × 24" × 17½"	24 lbs.	Each <del>190.00</del>

**ALERA.**



## Alera® Valencia™ Series Occasional Tables

**Simple classic design blends seamlessly into any decor.**

- Durable woodgrain laminate is water-, scratch- and dent-resistant featuring 3 mm protective edge banding.
- Leveling glides to compensate for uneven floors.
- Easy to assemble, just add legs.
- Manufacturer's limited five-year warranty.
- Meets or Exceeds ANSI/BIFMA Standards.

ID No.	Color	Size	Shpg. Wt.	Unit	Price
<b>H COFFEE TABLE</b>					
11	ALE-VA7548BK	Black	47¼" × 20" × 16½"	42 lbs.	Each <del>295.00</del>
12	ALE-VA7548MY	Mahogany	47¼" × 20" × 16½"	42 lbs.	Each <del>295.00</del>
<b>I END TABLE</b>					
13	ALE-VA7520BK	Black	23¾" × 20" × 20½"	27 lbs.	Each <del>170.00</del>
14	ALE-VA7520MY	Mahogany	23¾" × 20" × 20½"	27 lbs.	Each <del>170.00</del>





Pinnacle (PNC)



Espresso (ES)



Pinnacle (PNC)



Medium Cherry (MC)

HON® Foundation™ Conference Tables

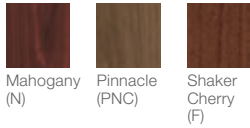

Mahogany (N) Pinnacle (PNC) Shaker Cherry (F)

Alera® Valencia™ Series Conference Room Furniture

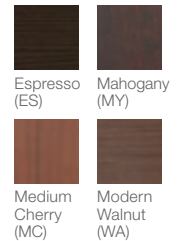

Espresso (ES) Mahogany (MY) Medium Cherry (MC) Modern Walnut (WA)



Foundation™ Conference Tables

The HON® Foundation™ Collection allows you to create a premium workspace on a limited budget.

- Table tops and bases are conveniently packaged and sold together.
- Bases feature adjustable leveling glides to compensate for uneven floors.
- Thermal-Fused Laminate top.
- Easy to assemble.
- Backed by the HON Limited Five-Year Warranty.
- Meets or Exceeds ISTA Performance Standards.

**A** RECTANGULAR CONFERENCE TABLE

Comfortably seats up to six people and sits atop a panel base, which has adjustable leveling glides to compensate for uneven floors. Table top and base are packaged together for convenient installation. Thermal Fused Laminate (TFL) top.

ID No.	Color	Size	Shpg. Wt.	Unit	Price
1 HON-LMC72RN	Mahogany	72" × 36" × 29½"	128 lbs.	Each	<del>367.00</del>
2 HON-LMC72RPNC	Pinnacle	72" × 36" × 29½"	128 lbs.	Each	<del>367.00</del>
3 HON-LMC72RF	Shaker Cherry	72" × 36" × 29½"	128 lbs.	Each	<del>367.00</del>

**B** ROUND CONFERENCE TABLE

Comfortably seats up to five people. The base has adjustable leveling glides to compensate for uneven floors. Table top and base are packaged together for convenient installation. Thermal Fused Laminate (TFL) top.

ID No.	Color	Size	Shpg. Wt.	Unit	Price
4 HON-LMC48DN	Mahogany	47" dia. × 29½"	88 lbs.	Each	<del>302.00</del>
5 HON-LMC48DPNC	Pinnacle	47" dia. × 29½"	88 lbs.	Each	<del>302.00</del>
6 HON-LMC48DF	Shaker Cherry	47" dia. × 29½"	88 lbs.	Each	<del>302.00</del>



Valencia™ Series Conference Room Furniture

Matching finishes with Valencia Series Modular Desking components.

- Durable woodgrain laminate top is water-, scratch- and dent-resistant with protective 3 mm edge banding.
- Leveling glides compensate for uneven floors.
- Manufacturer's limited five-year warranty.
- Meets or Exceeds ANSI/BIFMA Standards.

**C** RECTANGULAR CONFERENCE TABLES

Classic rectangular conference tables work for meetings, breakrooms, or quick-huddles.

ID No.	Color	Size	Shpg. Wt.	Unit	Price
<b>70½" Long</b> —Seats six comfortably.					
7 ALE-VA717242ES	Espresso	70½" × 41¾" × 29½"	156 lbs.	Each	<del>500.00</del>
8 ALE-VA717242MY	Mahogany	70½" × 41¾" × 29½"	159 lbs.	Each	<del>500.00</del>
9 ALE-VA717242MC	Medium Cherry	70½" × 41¾" × 29½"	160 lbs.	Each	<del>500.00</del>
10 ALE-VA717242WA	Modern Walnut	70½" × 41¾" × 29½"	153 lbs.	Each	<del>500.00</del>
<b>94½" Long</b> —Seats eight comfortably.					
11 ALE-VA719642ES	Espresso	94½" × 41¾" × 29½"	196 lbs.	Each	<del>605.00</del>
12 ALE-VA719642MY	Mahogany	94½" × 41¾" × 29½"	192 lbs.	Each	<del>605.00</del>
13 ALE-VA719642MC	Medium Cherry	94½" × 41¾" × 29½"	196 lbs.	Each	<del>605.00</del>
14 ALE-VA719642WA	Modern Walnut	94½" × 41¾" × 29½"	190 lbs.	Each	<del>605.00</del>

**D** ROUND CONFERENCE TABLES

A popular style for quick-huddle setups or any conference room. Straight leg X-base included.

ID No.	Color	Size	Shpg. Wt.	Unit	Price
<b>42" Diameter</b> —Seats 4 people.					
15 ALE-VA7142ES	Espresso	42" dia. × 29½"	80 lbs.	Each	<del>435.00</del>
16 ALE-VA7142MY	Mahogany	42" dia. × 29½"	80 lbs.	Each	<del>435.00</del>
17 ALE-VA7142MC	Medium Cherry	42" dia. × 29½"	80 lbs.	Each	<del>435.00</del>
18 ALE-VA7142WA	Modern Walnut	42" dia. × 29½"	80 lbs.	Each	<del>435.00</del>

Prices subject to change without notice. Visit our website for the latest pricing and product information.

# Tables Conference



See our full seating selection on pages 81-154.



## Medina™ Laminate Series

Combines Italian-influenced designs, style and durability with economical pricing.

- Silver detailing adds contemporary look.
- Grommet hole cutout size is 4" × 8".
- 250 lb. weight capacity.
- Table legs have cable chimney for concealed cable management from surface to floor.
- All floor supported models include steel leveling glides.
- Manufacturer's limited lifetime warranty.
- Green Leaf VOC Certified; Green Leaf VOC+ Certified.

Tops, Bases, Legs & Modesty Panels Sold Separately - ORDER ALL PARTS REQUIRED.

### A CONFERENCE TABLE TOP

ID No.	Color	W × D	Shpg. Wt.	Unit	Price
1 MLN-MNMT72STLGS	Gray Steel	72" × 48"	89 lbs.	Each	<del>799.00</del>
2 MLN-MNMT84STLGS	Gray Steel	84" × 48"	103 lbs.	Each	<del>970.00</del>
3 MLN-MNCT96LGS	Gray Steel	96" × 42"	133 lbs.	Each	<del>962.00</del>

### B CENTER TABLE LEG

ID No.	Height	Color	Shpg. Wt.	Unit	Price
4 MLN-MNMTSLGGS	28½" - 28¾"	Gray Steel	29 lbs.	Each	<del>247.00</del>

### C TABLE LEGS

ID No.	Height	Color	Shpg. Wt.	Unit	Price
5 MLN-MNCBLS	28¾"	Gray Steel	89 lbs.	Each	<del>363.00</del>

### D MODESTY PANELS

ID No.	Color	Size	Shpg. Wt.	Unit	Price
6 MLN-MNCT120MPLSL	Gray Steel	82½" × ¾" × 11½"	71 lbs.	Each	<del>236.00</del>

### E ROUND CONFERENCE TABLE

ID No.	Color	Size	Shpg. Wt.	Unit	Price
7 MLN-MNCR48LGS	Gray Steel	48" dia. × 29½"	90 lbs.	Each	<del>720.00</del>



Gray Steel



### F - G LOW WALL CABINET WITH DOORS

Self-closing hinged doors. One shelf on each side adjusts in 1/4" increments. Two sets of doors lock separately but are keyed alike.

Cabinet and Doors sold and shipped separately—ORDER BOTH.

ID No.	Color	W × D × H	Shpg. Wt.	Unit	Price
<b>F BOX 1 OF 2 (CABINET)</b>					
8 MLN-MVLCCLGS	Gray Steel	72" × 20" × 29½"	141 lbs.	Each	<del>829.00</del>
<b>G BOX 2 OF 2 (DOORS)</b>					
9 MLN-MVLCDLGS	Gray Steel	72" × 20" × 29½"	40 lbs.	Each	<del>346.00</del>

### H PRESENTATION BOARD

ID No.	W × H	Frame Color	Shpg. Wt.	Unit	Price
10 MLN-MNPBLGS	48" × 48"	Gray Steel	90 lbs.	Each	<del>315.00</del>

#### ORDERING INSTRUCTIONS BASED ON TABLE SIZE NEEDED

##### 8-FT. TABLE

Qty.	Item No.	Description
1	MNCT96LGS	<b>Table Top</b>
1	MNCBLS	<b>Table Legs</b>

##### 10-FT. TABLE

Qty.	Item No.	Description
2	MNCT120TLGS	<b>Table Top</b>
1	MNCBLS	<b>Table Legs</b>
1	MNCT120MPLSL	<b>Modesty Panel</b>

##### 12-FT. TABLE

Qty.	Item No.	Description
2	MNMT72STLGS	<b>Table Top</b>
1	MNMTSLGGS	<b>Center Table Leg</b>
1	MNCBLS	<b>Table Legs</b>

##### 14-FT. TABLE

Qty.	Item No.	Description
2	MNMT84STLGS	<b>Table Top</b>
1	MNMTSLGGS	<b>Center Table Leg</b>
1	MNCBLS	<b>Table Legs</b>



Tables shown in Silver Mesh with HON Ignition® Multipurpose Chairs.

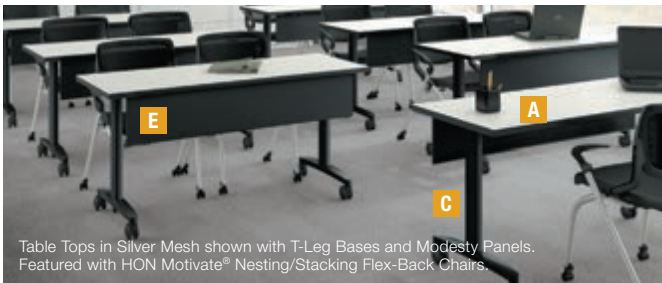
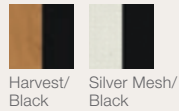

Table Tops in Silver Mesh shown with T-Leg Bases and Modesty Panels. Featured with HON Motivate® Nesting/Stacking Flex-Back Chairs.



Table Tops in Harvest shown with Post Leg Table Bases.



**HON.**



## Huddle Series Multipurpose Tables

### Tables that welcome change.

- Ultra-flexible multipurpose tables are easy to set up and may be quickly reconfigured as needed.
- Durable laminate table tops.
- Underside pilot holes accommodate all Huddle Series bases.
- Overall table height with base is 29½" h.
- Four casters (two locking) provide quick and easy mobility.
- Backed by the HON Full Lifetime Warranty.
- Contains 84% pre-consumer recycled content, 1% post-consumer recycled content.
- Level 1 Certified; Meets or Exceeds ANSI/BIFMA Standards; SCS Indoor Advantage Gold Certified.

Table Tops and Legs Sold Separately - ORDER BOTH

#### A MULTIPURPOSE RECTANGULAR TOP WITHOUT GROMMETS

Underside of 72" tops includes a hat channel to deter warping and bowing.

ID No.	Color	W x D	Shpg. Wt.	Unit	Price
<b>72" Wide Tops</b>					
1	HON-MT3072GNCP	Harvest/Black	72" x 30"	85 lbs.	Each <del>449.00</del>
2	HON-MT3072GNB9P	Silver Mesh/Black	72" x 30"	85 lbs.	Each <del>449.00</del>
3	HON-MT2472GNCP	Harvest/Black	72" x 24"	68 lbs.	Each <del>422.00</del>
4	HON-MT2472GNB9P	Silver Mesh/Black	72" x 24"	68 lbs.	Each <del>422.00</del>
<b>60" Wide Tops</b>					
5	HON-MT3060GNCP	Harvest/Black	60" x 30"	71 lbs.	Each <del>399.00</del>
6	HON-MT3060GNB9P	Silver Mesh/Black	60" x 30"	71 lbs.	Each <del>399.00</del>
7	HON-MT2460GNCP	Harvest/Black	60" x 24"	57 lbs.	Each <del>381.00</del>
8	HON-MT2460GNB9P	Silver Mesh/Black	60" x 24"	57 lbs.	Each <del>381.00</del>

#### B FLIP-TOP TABLE BASE

Tables nest easily for space-efficient storage. Advanced hinge mechanism for quiet and safe operation. Four casters (two locking) provide quick and easy mobility.

ID No.	Height	Color	Shpg. Wt.	Unit	Price
<b>For 30" Deep Tops</b>					
9	HON-MFLIP30CP	28¾"	Black	27 lbs.	Each <del>613.00</del>
<b>For 24" Deep Tops</b>					
10	HON-MFLIP24CP	28¾"	Black	27 lbs.	Each <del>613.00</del>

#### C T-LEG TABLE BASE

Lightweight yet durable aluminum construction. T-Leg style offers unobstructed leg room. Four casters (two locking) for quick and easy mobility.

ID No.	Height	Color	Shpg. Wt.	Unit	Price
<b>For 24" and 30" Deep Tops</b>					
11	HON-MTLEG24CP	28¾"	Black	14 lbs.	Carton <del>418.00</del>

#### D POST LEG TABLE BASE

Heavy-duty steel offers strength and stability. Four casters (two locking) for quick and easy mobility.

ID No.	Height	Color	Shpg. Wt.	Unit	Price
<b>For 24" and 30" Deep Tops</b>					
12	HON-MBPOSTCP	28¾"	Black	18 lbs.	Carton <del>352.00</del>

#### E UNIVERSAL MODESTY PANEL

Flips down and out of the way to accommodate easy nesting when used with Flip-Top Table Base. Template included allows for quick and easy installation.

ID No.	Color	W x D	Unit	Price
<b>For 60" and 72" Wide Tops</b>				
13	HON-MTUMOD4P	Black	44.5" x 9.63"	Each <del>227.00</del>

#### F HUDDLE GANGING HARDWARE

Allows tables to be ganged side-to-side or front-to-back. Backed by the HON Full Lifetime Warranty. Contains 70% pre-consumer recycled content, 3% post-consumer recycled content.

ID No.	Color	Qty.	Unit	Price
14	HON-MAGANG	Black	1	Each <del>89.00</del>

Prices subject to change without notice. Visit our website for the latest pricing and product information.



Ribbon and Wisp Shape Tables in Tangerine with Motivate™ Flex Back Chairs in alternate fabric. Contact us for details.

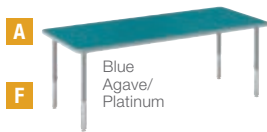

A

Blue  
Agave/  
Platinum

F



B

Silver  
Mesh/  
Platinum

E

Shown with optional casters



C

Blue  
Agave/  
Platinum

F



D

Natural  
Maple/  
Platinum

F

## HON.



## Build™ Tables

Flexible, scalable collection of worksurface shapes and sizes that can support any size group or type of activity.

- High-Pressure Laminate (HPL) top.
- Three Laminate colors to choose from; T-mold color is Platinum.
- Post Legs adjust from 25" h to 34" h in 1" increments, chrome bottoms.
- Glides and optional casters easily move across all surfaces.
- Backed by the HON Full Lifetime Warranty.
- Contains 8% post-consumer recycled content, 37% total recycled content.
- Level 2 Certified; Meets or Exceeds ANSI/BIFMA and ISTA Performance Standards; SCS Indoor Advantage Gold Certified.

Table Tops and Legs Sold Separately - ORDER BOTH

### A RECTANGLE TABLE TOP

Traditional table-top supports up to six people, alone; but when you combine it with additional components, you can create endless configurations.

ID No.	Color	Size	Shpg. Wt.	Unit	Price
1 HON-TR2460ENB9K	Silver Mesh	60" × 24" × 1"	57 lbs.	Each	<del>384.00</del>
2 HON-TR2460ENBA1K	Blue Agave	60" × 24" × 1"	57 lbs.	Each	<del>384.00</del>
3 HON-TR2460ENDK	Natural Maple	60" × 24" × 1"	57 lbs.	Each	<del>384.00</del>
4 HON-TR2460E_	(Special Order)	60" × 24" × 1"	57 lbs.	Each	<del>384.00</del>

### B HALF-ROUND TABLE TOP

Traditional half-round shape can be combined with another half-round to create a full circle or added to the end of a rectangle table to create a J configuration.

ID No.	Color	Size	Shpg. Wt.	Unit	Price
5 HON-SH3060ENB9K	Silver Mesh	60" × 30" × 1"	69 lbs.	Each	<del>437.00</del>
6 HON-SH3060ENBA1K	Blue Agave	60" × 30" × 1"	69 lbs.	Each	<del>437.00</del>
7 HON-SH3060ENDK	Natural Maple	60" × 30" × 1"	69 lbs.	Each	<del>437.00</del>
8 HON-SH3060E_	(Special Order)	60" × 30" × 1"	69 lbs.	Each	<del>437.00</del>

### C RIBBON TABLE TOP

Ride the wave of collaboration with this unique table top. A single wave-shaped ribbon accommodates up to six people.

ID No.	Color	Size	Shpg. Wt.	Unit	Price
9 HON-SW3054ENB9K	Silver Mesh	54" × 30" × 1"	65 lbs.	Each	<del>400.00</del>
10 HON-SW3054ENBA1K	Blue Agave	54" × 30" × 1"	65 lbs.	Each	<del>400.00</del>
11 HON-SW3054ENDK	Natural Maple	54" × 30" × 1"	65 lbs.	Each	<del>400.00</del>
12 HON-SW3054E_	(Special Order)	54" × 30" × 1"	65 lbs.	Each	<del>400.00</del>

### D WISP TABLE TOP

If you carved a soft wave into the straight side of a half-round top, you'd get the unique Wisp. Combine two to create a whole circle, or combine six to create a spiral. The possibilities are limited only by your imagination.

ID No.	Color	Size	Shpg. Wt.	Unit	Price
13 HON-SN3054ENB9K	Silver Mesh	54" × 30" × 1"	63 lbs.	Each	<del>450.00</del>
14 HON-SN3054ENBA1K	Blue Agave	54" × 30" × 1"	63 lbs.	Each	<del>450.00</del>
15 HON-SN3054ENDK	Natural Maple	54" × 30" × 1"	63 lbs.	Each	<del>450.00</del>
16 HON-SN3054E_	(Special Order)	54" × 30" × 1"	63 lbs.	Each	<del>450.00</del>

### E HEIGHT-ADJUSTABLE BASE CASTER ADD-ON KIT

Black locking casters replace existing standard glides that come standard on the height adjustable table bases. Easily installs into the existing glide receptacle. Comes in pack of 4.

ID No.	Stems	Wheel Tread	Qty.	Unit	Price
17 HON-HABCASTER	Grip Ring	Hard	4	Pack	<del>75.00</del>

### F ADJUSTABLE POST LEGS

Glides and optional casters allow for easy movement on all surfaces.

ID No.	Color	Size	Shpg. Wt.	Qty.	Unit	Price
18 HON-B4LEGP	Black	22" - 34"	19 lbs.	4	Pack	<del>195.00</del>
19 HON-B4LEGT1	Platinum	22" - 34"	19 lbs.	4	Pack	<del>195.00</del>





Ribbon Shaped Tables in Pinnacle shown with Ignition® Multi-purpose Chairs in alternate fabric. Contact us for details.



Rectangle Shaped Tables in Pinnacle shown with Accommodate Guest Chairs in alternate fabric and finish. Contact us for details.

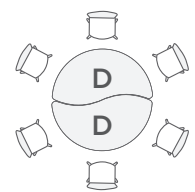
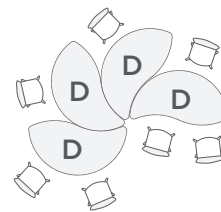
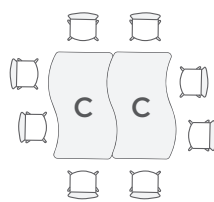
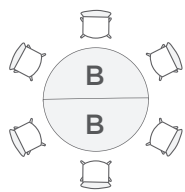
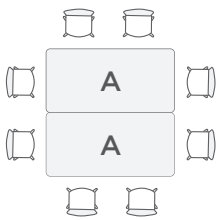

Rectangle Shaped Tables in Blue Agave shown with Motivate® Chairs in alternate fabric and finish. Contact us for details.

## HEIGHT-ADJUSTABILITY



Ranges from 22"-34" in 1" increments

### In-Stock Laminate



Blue Agave (NBA1K)



Silver Mesh (NB9K)



Natural Maple (NDK)

### In-Stock Leg Color



Platinum (GT)



Black (GP)

### Special Order Laminate



Kiwi (KW1K)



Pinnacle (PNCK)



Pomegranate (BG1K)



Tangerine (TG1K)



Requires additional lead time and cannot be returned.

**\*IMPORTANT:** When ordering special order items, add the finish code to the model number. Codes vary in length and placement. Example: ABC-12345AB



**HON.**

## Between™ Nesting Tables

Selection of mobile and nesting tables to support meetings and collaborative work.

- Large casters make moving tables easy as your needs change.
- Base flips the worksurface vertically to nest with other tables to save space.
- Scratch-, spill- and stain-resistant laminate stands up to heavy use.
- Rectangular worksurface gives up to four people space to collaborate.
- 1½" thick worksurface provides a sturdy foundation for work.
- Durable 2mm edgeband provides a smooth, comfortable edge.
- Table and base are bundled together.
- Order one SKU, get both.
- Backed by the HON Full Lifetime Warranty.
- Meets or Exceeds ANSI/BIFMA Standards.



**A**

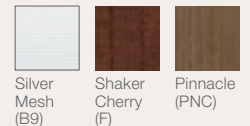

**B**



**C**



**D**



### A NESTED MULTIPURPOSE TABLES

High-Pressure Laminate (HPL) top.

ID No.	No.	Color	Size	Shpg. Wt.	Unit	Price
<b>24" Tables</b>						
1	HON-PT2448NSPINC	Pinnacle	48" x 24" x 29"	69 lbs.	Each	<del>570.00</del>
2	HON-PT2448NSFF	Shaker Cherry	48" x 24" x 29"	69 lbs.	Each	<del>570.00</del>
3	HON-PT2448NSB9LT	Silver Mesh/Loft	48" x 24" x 29"	69 lbs.	Each	<del>570.00</del>
4	HON-PT2460NSPINC	Pinnacle	60" x 24" x 29"	81 lbs.	Each	<del>629.00</del>
5	HON-PT2460NSFF	Shaker Cherry	60" x 24" x 29"	81 lbs.	Each	<del>629.00</del>
6	HON-PT2460NSB9LT	Silver Mesh/Loft	60" x 24" x 29"	81 lbs.	Each	<del>629.00</del>
7	HON-PT2472NSPINC	Pinnacle	72" x 24" x 29"	92 lbs.	Each	<del>665.00</del>
8	HON-PT2472NSFF	Shaker Cherry	72" x 24" x 29"	92 lbs.	Each	<del>665.00</del>
9	HON-PT2472NSB9LT	Silver Mesh/Loft	72" x 24" x 29"	92 lbs.	Each	<del>665.00</del>
<b>30" Tables</b>						
10	HON-PT3048NSPINC	Pinnacle	48" x 30" x 29"	81 lbs.	Each	<del>591.00</del>
11	HON-PT3048NSFF	Shaker Cherry	48" x 30" x 29"	81 lbs.	Each	<del>591.00</del>
12	HON-PT3048NSB9LT	Silver Mesh/Loft	48" x 30" x 29"	81 lbs.	Each	<del>591.00</del>
13	HON-PT3060NSPINC	Pinnacle	60" x 30" x 29"	95 lbs.	Each	<del>640.00</del>
14	HON-PT3060NSFF	Shaker Cherry	60" x 30" x 29"	95 lbs.	Each	<del>640.00</del>
15	HON-PT3060NSB9LT	Silver Mesh/Loft	60" x 30" x 29"	95 lbs.	Each	<del>640.00</del>
16	HON-PT3072NSPINC	Pinnacle	72" x 30" x 29"	109 lbs.	Each	<del>689.00</del>
17	HON-PT3072NSFF	Shaker Cherry	72" x 30" x 29"	109 lbs.	Each	<del>689.00</del>
18	HON-PT3072NSB9LT	Silver Mesh/Loft	72" x 30" x 29"	109 lbs.	Each	<del>689.00</del>

### B UNIVERSAL MODESTY PANELS

Flips down and out of the way to accommodate easy nesting when used with Flip-Top Table Base. Template included allows for quick and easy installation.

ID No.	No.	Color	W x D	Unit	Price
<b>For 48" Tables</b>					
19	HON-MTUMOD38P	Black	38" x 9.63"	Each	<del>210.00</del>
<b>For 60" and 72" Tables</b>					
20	HON-MTUMOD50P	Black	50" x 9.63"	Each	<del>238.00</del>

## Assemble™ Stacking/ Nesting Chairs

Perfect for multipurpose areas, training spaces and anywhere reconfiguration and space are priorities.

- Contemporary folding/nesting design with a flip-up seat.
- Breathable mesh back conforms to user's upper body.
- Generous foam seat cushion provides plush comfort and reduces pressure points.
- Integrated casters are designed to nest with frame to maximize space.
- Warranted for users up to 250 lbs.
- Ships two chairs per carton.
- Backed by the HON Limited Five-Year Warranty.
- Meets or Exceeds ISTA Standards.

ID No.	No.	Base Color	Shpg. Wt.	Qty.	Unit	Price
<b>C ARMLESS STACKING/NESTING CHAIR</b>						
Seat: 18" x 19" Back: 17" x 18" Overall height: 35".						
21	BSX-VL304BLK	Black	44 lbs.	2	Carton	<del>533.00</del>
22	BSX-VL304SLVR	Silver	44 lbs.	2	Carton	<del>533.00</del>
<b>D STACKING/NESTING CHAIR WITH ARMS</b>						
Seat: 18" x 19" Back: 17" x 18" Overall height: 35".						
23	BSX-VL314BLK	Black	44 lbs.	2	Carton	<del>557.00</del>
24	BSX-VL314SLVR	Silver	44 lbs.	2	Carton	<del>557.00</del>

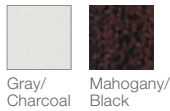

Graphite and Gray Walnut Table Tops come with Silver Legs. Walnut Table Top comes with Silver Legs.

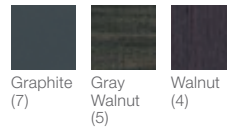

## OfficeWorks™ Mobile Training Tables

Functional, durable mobile training tables easily reconfigure to improve meeting productivity.

- Wear-resistant melamine top.
- Perforated steel modesty panel.
- Strong, 1-1/2" offset dual legs for maximum legroom.
- 3" diameter casters (two locking).
- Tops and legs sold together in one carton.
- Manufacturer's limited fifteen-year warranty.
- Meets or Exceeds ANSI/BIFMA Standards.

### A MOBILE TRAINING TABLE

Melamine laminate top. Supports up to 200 lbs. evenly distributed.

ID No.	Color	Size	Shpg. Wt.	Unit	Price
<b>72" Wide</b>					
1	ICE-68067	Gray/Charcoal	72" x 18" x 29"	45 lbs.	Each <del>493.00</del>
2	ICE-68068	Mahogany/Black	72" x 18" x 29"	45 lbs.	Each <del>493.00</del>
<b>60" Wide</b>					
3	ICE-68057	Gray/Charcoal	60" x 18" x 29"	39 lbs.	Each <del>426.00</del>
4	ICE-68058	Mahogany/Black	60" x 18" x 29"	39 lbs.	Each <del>426.00</del>



## ARC Sit-to-Stand Adjustable Height Table

Sturdy, versatile all-purpose table was designed for flexible work spaces and can be utilized in all areas of the office where communication and collaboration take place.

- Perfectly suited for use as a workstation, meeting/conference table or a lounge/cafe table.
- Ergonomically healthy options—sitting, standing or leaning—help you keep a more active work posture.
- Multiple height positions at 3" increments, can be pre-set with spring button clips.
- 1-1/8" thick melamine laminate top supports up to 225 lbs. evenly distributed.
- Steel tubular legs with arched style base and adjustable levers.
- Manufacturer's limited fifteen-year warranty.
- Meets or Exceeds ANSI/BIFMA Standards.

ID No.	Color	Size	Shpg. Wt.	Unit	Price
<b>B RECTANGULAR</b>					
5	ICE-69327	Graphite	36" x 72" x 42"	96 lbs.	Each <del>625.00</del>
6	ICE-69325	Gray Walnut	36" x 72" x 42"	96 lbs.	Each <del>625.00</del>
7	ICE-69324	Walnut	36" x 72" x 42"	96 lbs.	Each <del>625.00</del>
8	ICE-69317	Graphite	60" x 30" x 42"	76 lbs.	Each <del>460.00</del>
9	ICE-69315	Gray Walnut	30" x 60" x 42"	76 lbs.	Each <del>460.00</del>
10	ICE-69314	Walnut	30" x 60" x 42"	76 lbs.	Each <del>460.00</del>
11	ICE-69305	Gray Walnut	30" x 48" x 48"	75 lbs.	Each <del>402.00</del>
<b>C OVAL</b>					
12	ICE-69627	Graphite	36" x 72" x 42"	86 lbs.	Each <del>625.00</del>
13	ICE-69625	Gray Walnut	36" x 72" x 42"	86 lbs.	Each <del>625.00</del>
14	ICE-69624	Walnut	36" x 72" x 42"	86 lbs.	Each <del>625.00</del>

Prices subject to change without notice. Visit our website for the latest pricing and product information.



# Tables Training

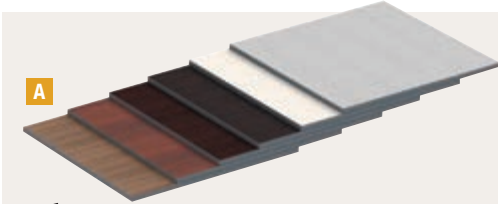

## Reversible Laminate Table Tops

Take your pick. Multiple sizes and colors to create your own unique desk, table or workstation.

- Reversible table tops have a different color and pattern on each side with coordinating dark gray edge banding.
- Use with Alera® bases to create height adjustable workstations, training tables, collaborative spaces or standard desks.
- Durable laminate is water-, scratch-, and dent-resistant.
- Coordinating colors with Alera® Valencia™ and Open Office Suites.
- Commercial grade, 1" thick top.
- Manufacturer's limited five-year warranty.
- Meets or Exceeds ANSI/BIFMA Standards.

Table tops and bases sold and shipped separately—ORDER BOTH.

### A REVERSIBLE TABLE TOP

ID No.	Color	Size	Shpg. Wt.	Unit	Price
1	ALE-TT7230EW	Espresso/Walnut	71½" × 29½"	58 lbs.	Each <del>269.00</del>
2	ALE-TT7230CM	Medium Cherry/Mahogany	71½" × 29½"	58 lbs.	Each <del>269.00</del>
3	ALE-TT7230WG	White/Gray	71½" × 29½"	58 lbs.	Each <del>269.00</del>
4	ALE-TT7224EW	Espresso/Walnut	71½" × 23¾"	48 lbs.	Each <del>199.00</del>
5	ALE-TT7224CM	Medium Cherry/Mahogany	71½" × 23¾"	48 lbs.	Each <del>199.00</del>
6	ALE-TT7224WG	White/Gray	71½" × 23¾"	48 lbs.	Each <del>199.00</del>
7	ALE-TT6030EW	Espresso/Walnut	59½" × 29½"	46 lbs.	Each <del>239.00</del>
8	ALE-TT6030CM	Medium Cherry/Mahogany	59½" × 29½"	46 lbs.	Each <del>239.00</del>
9	ALE-TT6030WG	White/Gray	59½" × 29½"	49 lbs.	Each <del>239.00</del>
10	ALE-TT6024EW	Espresso/Walnut	59½" × 23¾"	40 lbs.	Each <del>169.00</del>
11	ALE-TT6024CM	Medium Cherry/Mahogany	59½" × 23¾"	40 lbs.	Each <del>169.00</del>
12	ALE-TT6024WG	White/Gray	59½" × 23¾"	40 lbs.	Each <del>169.00</del>
13	ALE-TT4824EW	Espresso/Walnut	47¾" × 23¾"	33 lbs.	Each <del>149.00</del>
14	ALE-TT4824CM	Medium Cherry/Mahogany	47¾" × 23¾"	33 lbs.	Each <del>149.00</del>
15	ALE-TT4824WG	White/Gray	47¾" × 23¾"	33 lbs.	Each <del>149.00</del>

## Valencia™ Series Training/ Meeting Room Tables

Collaborate more easily — rearrange tables in multiple configurations to suit the environment and moment.

- Durable, water-, scratch- and dent-resistant woodgrain laminate tops with protective 3 mm edge banding.
- Durable chip- and scratch-resistant powder-coated steel bases.
- Cable-management grommets and wire troughs keep everything neat and organized.
- Manufacturer's limited five-year warranty.
- Meets or Exceeds ANSI/BIFMA Standards.

Tops and bases sold separately—ORDER BOTH.

### B EASY-LEVER FLIP-DOWN & NEST TABLE BASE

With a handy lever on both sides, simply flip-up for fast setup or flip-down to nest away. Vertically aligned nesting design ensures a small storage footprint. Includes detachable punched-metal privacy panel. Four locking casters for mobility or four glides for fixed usage. All hardware included.

ID No.	Height	Color	Shpg. Wt.	Unit	Price
<b>Large</b> —For 60" to 72" wide tops.					
16	ALE-VA7276BK	28¾"	Black	35 lbs.	Each <del>435.00</del>
<b>Standard</b> —For 36" to 48" wide tops.					
17	ALE-VA7243BK	28¾"	Black	31 lbs.	Each <del>375.00</del>

### C FLIP-DOWN & NEST T-LEG TABLE BASE

Flip-up for fast setup; fold-down for easy nesting. Includes a detachable punched-metal privacy panel. Hardware included.

ID No.	Height	Color	Shpg. Wt.	Unit	Price
<b>Large</b> —For 60" to 72" tops.					
18	ALE-VA737260BK	28¾"	Black	44 lbs.	Kit <del>385.00</del>
<b>Standard</b> —For 48" tops.					
19	ALE-VA734836BK	28¾"	Black	29 lbs.	Kit <del>350.00</del>

### D FIXED T-LEG BASES

Sturdy bases are compatible with most tabletops. Ideal for where space and configuration is well defined.



ID No.	Height	Color	Shpg. Wt.	Unit	Price
<b>Large</b> —For 60" to 72" tops.					
20	ALE-VA7476BK	28¾"	Black	24 lbs.	Kit <del>285.00</del>
<b>Standard</b> —For 48" tops.					
21	ALE-VA7443BK	28¾"	Black	20 lbs.	Kit <del>249.00</del>





## Flip-n-Go® Tables

An excellent solution for your training or conference room needs.

- Minimal assembly required.
- Dual-sided levers flip table tops from horizontal to vertical.
- Surfaces effortlessly flip to a vertical position allowing multiple tables to nest together for compact storage.
- With a simple release of a lever, the surfaces return to working position and are ready to be rolled back into action.
- Manufacturer's limited lifetime warranty.
- Green Leaf VOC Certified; Green Leaf VOC+ Certified.  

Top and Base sold and shipped separately—ORDER BOTH.

### A TABLE TOP

1" thick thermally fused laminate top with standard T-mold edge for use with Flip-n-Go® bases. CARB compliant, particle board core. Pilot holes in top make for easy assembly to the base.

ID No.	Color	W x D	Shpg. Wt.	Unit	Price
1 MLN-2472TFLK4	Folkstone	72" x 24"	60 lbs.	Each	<del>290.00</del>
2 MLN-2472TLDCM	Mocha	72" x 24"	60 lbs.	Each	<del>290.00</del>
3 MLN-1872TFLK4	Folkstone	72" x 18"	45 lbs.	Each	<del>450.00</del>
4 MLN-1872TLDCM	Mocha	72" x 18"	45 lbs.	Each	<del>220.00</del>
5 MLN-2460TFLK4	Folkstone	60" x 24"	55 lbs.	Each	<del>204.00</del>
6 MLN-2460TLDCM	Mocha	60" x 24"	55 lbs.	Each	<del>204.00</del>
7 MLN-1860TFLK4	Folkstone	60" x 18"	35 lbs.	Each	<del>190.00</del>
8 MLN-1860TLDCM	Mocha	60" x 18"	35 lbs.	Each	<del>200.00</del>
9 MLN-2448TFLK4	Folkstone	48" x 24"	40 lbs.	Each	<del>240.00</del>
10 MLN-2448TLDCM	Mocha	48" x 24"	40 lbs.	Each	<del>240.00</del>
11 MLN-1848TFLK4	Folkstone	48" x 18"	30 lbs.	Each	<del>107.00</del>
12 MLN-1848TLDCM	Mocha	48" x 18"	30 lbs.	Each	<del>107.00</del>

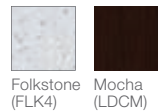

### B TABLE BASE

Steel base with integrated modesty panel with built-in cable trough. Four locking casters.

ID No.	Height	Color	Shpg. Wt.	Unit	Price
<b>For 72" Table Tops</b>					
13 MLN-LF72S5	27 7/8"	Black	45 lbs.	Each	<del>510.00</del>
14 MLN-LF72SLV	27 7/8"	Silver	45 lbs.	Each	<del>510.00</del>
<b>For 60" Table Tops</b>					
15 MLN-LF60S5	27 7/8"	Black	41 lbs.	Each	<del>400.00</del>
16 MLN-LF60SLV	27 7/8"	Silver	41 lbs.	Each	<del>400.00</del>
<b>For 48" Table Tops</b>					
17 MLN-LF48S5	27 7/8"	Black	38 lbs.	Each	<del>440.00</del>
18 MLN-LF48SLV	27 7/8"	Silver	38 lbs.	Each	<del>440.00</del>



Prices subject to change without notice. Visit our website for the latest pricing and product information.

# Tables Utility & Folding



**HON.**

## Utility Tables

All-purpose tables for all applications.

- Durable laminate top with painted apron.
- Chrome legs attach easily with bracket-style assembly.
- Leveling glides help prevent table from rocking.
- Backed by the HON Full Lifetime Warranty.
- Contains 10% pre-consumer recycled content, 12% post-consumer recycled content.
- Level 2 Certified; Meets or exceeds ANSI/BIFMA and ISTA Performance Standards; SCS Indoor Advantage Gold Certified.

### A UTILITY TABLE

High-pressure laminate top.

ID No.	Color	Size	Shpg. Wt.	Unit	Price
1 HON-UTM3672CLCHR	Harvest/Putty	72" x 36" x 29"	116 lbs.	Each	<del>640.00</del>
2 HON-UTM3672LOLOC	Light Gray	72" x 36" x 29"	116 lbs.	Each	<del>640.00</del>
3 HON-UTM3672MOPCH	Mocha/Black	72" x 36" x 29"	116 lbs.	Each	<del>640.00</del>
4 HON-UTM3072CLCHR	Harvest/Putty	72" x 30" x 29"	106 lbs.	Each	<del>610.00</del>
5 HON-UTM3072LOLOC	Light Gray	72" x 30" x 29"	106 lbs.	Each	<del>610.00</del>
6 HON-UTM3072MOPCH	Mocha/Black	72" x 30" x 29"	106 lbs.	Each	<del>610.00</del>
7 HON-UTM1872CLCHR	Harvest/Putty	72" x 18" x 29"	73 lbs.	Each	<del>404.00</del>
8 HON-UTM1872LOLOC	Light Gray	72" x 18" x 29"	73 lbs.	Each	<del>404.00</del>
9 HON-UTM1872MOPCH	Mocha/Black	72" x 18" x 29"	73 lbs.	Each	<del>404.00</del>
10 HON-UTM3060CLCHR	Harvest/Putty	60" x 30" x 29"	88 lbs.	Each	<del>409.00</del>
11 HON-UTM3060LOLOC	Light Gray	60" x 30" x 29"	88 lbs.	Each	<del>409.00</del>
12 HON-UTM3060MOPCH	Mocha/Black	60" x 30" x 29"	88 lbs.	Each	<del>409.00</del>
13 HON-UTM2060CLCHR	Harvest/Putty	60" x 20" x 29"	68 lbs.	Each	<del>440.00</del>
14 HON-UTM2060LOLOC	Light Gray	60" x 20" x 29"	68 lbs.	Each	<del>440.00</del>
15 HON-UTM2060MOPCH	Mocha/Black	60" x 20" x 29"	68 lbs.	Each	<del>440.00</del>



## B BARRICKS

### B UTILITY TABLE

An easy way to expand your work area. Create space for fax machine, small copier or even the coffee maker. Non-folding design stands up to long-term use. Special finish on frame helps reduce scratches. Woodgrain laminate top. Supports up to 500 lbs. evenly distributed. Contains 75% pre-consumer recycled content.

ID No.	Color	Size	Shpg. Wt.	Unit	Price
16 BRK-UT1860WA	Walnut/Black	60" x 18" x 30"	45 lbs.	Each	<del>219.00</del>
17 BRK-UT244830WA	Walnut/Black	48" x 24" x 30"	39 lbs.	Each	<del>211.00</del>
18 BRK-UTS1848LQ	Oak/Brown	48" x 18" x 30"	59 lbs.	Each	<del>211.00</del>
19 BRK-UTS1848WA	Walnut/Black	48" x 18" x 30"	59 lbs.	Each	<del>211.00</del>
20 BRK-UT183030LQ	Oak/Brown	30" x 18" x 30"	32 lbs.	Each	<del>176.00</del>
21 BRK-UT183030WA	Walnut/Black	30" x 18" x 30"	32 lbs.	Each	<del>176.00</del>

\* BRK-UTS1848LQ, BRK-UTS1848WA—Includes a bottom storage shelf.

### C SPECIAL SIZE FOLDING TABLE

Provides comfortable seating for many. Security lock holds table firmly closed. End seating is unobstructed. Steel apron for support. Laminate top. Supports up to 500 lbs. evenly distributed. Contains 75% pre-consumer recycled content.

ID No.	Color	Size	Shpg. Wt.	Unit	Price
<b>Rectangular—Closed 4".</b>					
22 BRK-CL2472WA	Walnut/Black	72" x 24" x 30"	65 lbs.	Each	<del>300.00</del>
23 BRK-CL1872WA	Walnut/Black	72" x 18" x 30"	59 lbs.	Each	<del>201.00</del>
24 BRK-CL2460WA	Walnut/Black	60" x 24" x 30"	59 lbs.	Each	<del>292.00</del>
25 BRK-CL1860WA	Walnut/Black	60" x 18" x 30"	55 lbs.	Each	<del>263.00</del>
<b>Square—Closed 3".</b>					
26 BRK-CL36WA	Walnut/Black	36" x 36" x 30"	75 lbs.	Each	<del>257.00</del>

### D ECONOMY FOLDING CONFERENCE TABLE

Finally, a conference table that has everything you need—quick and easy set-up with no assembly required. "Press-O-Matic" lock secures leg, releases with just a touch. Easy-care laminate top. Adjustable leveling glides. Laminate top. Supports up to 1,000 lbs. evenly distributed. Contains 75% pre-consumer recycled content.

ID No.	Color	Size	Shpg. Wt.	Unit	Price
27 BRK-ECT368WA	Walnut/Black	96" x 36" x 30"	139 lbs.	Each	<del>566.00</del>
28 BRK-ECT366WA	Walnut/Black	72" x 36" x 30"	119 lbs.	Each	<del>400.00</del>



Single cam folded release for one-handed set up.



## Maxx Legroom Table

Open corner leg design for maximum legroom and seating capacity.

- Single cam, quick release leg lever for easy set up; folds flat for compact storage.
- Innovative open corner leg design eliminates the need for a cross bar, providing maximum leg room and fits seating on all sides.
- Non-mar feet.
- Wear-resistant melamine top and heavy-duty 1½" powder coated steel legs.
- Bumpers protect tables when stacked.
- Manufacturer's limited 15-year warranty.
- Meets or exceeds ANSI/BIFMA Standards.

### A - B FOLDING TABLE

Melamine laminate top supports up to 1,100 lbs. evenly distributed.

ID No.	Color	Size	Shpg. Wt.	Unit	Price
<b>A RECTANGULAR</b>					
1	ICE-65837	Gray	96" x 30" x 29½"	109 lbs.	Each <del>651.96</del>
2	ICE-65827	Gray	72" x 30" x 29½"	87 lbs.	Each <del>504.96</del>
3	ICE-65887	Gray	72" x 18" x 29½"	62 lbs.	Each <del>449.96</del>
4	ICE-65877	Gray	60" x 18" x 29½"	54 lbs.	Each <del>391.96</del>
5	ICE-65807	Gray	48" x 24" x 29½"	53 lbs.	Each <del>366.96</del>
<b>B ROUND</b>					
6	ICE-65867	Gray	60" dia. x 29½"	93 lbs.	Each <del>661.96</del>

## Wood Folding Tables

A traditional look that will coordinate with any environment.

- Wear-resistant with vinyl T-mold edge.
- Melamine sealed underside helps prevent moisture absorption.
- 1" diameter, heavy gauge steel legs with heavy-duty protective foot caps.
- Heavy-duty leg supports and gravity leg lock for secure set-up.
- Folds to 2½" for easy storage.
- Manufacturer's limited 15-year warranty.
- Meets or exceeds ANSI/BIFMA Standards.

### C PREMIUM WOOD LAMINATE FOLDING TABLE

Full perimeter steel skirt with four plastic protective corners for safe stacking. ¾" thick melamine top, supports up to 1,000 lbs. evenly distributed.

ID No.	Color	Size	Shpg. Wt.	Unit	Price
7	ICE-55237	Gray	96" x 30" x 29"	84 lbs.	Each <del>326.95</del>
8	ICE-55234	Mahogany	96" x 30" x 29"	84 lbs.	Each <del>326.95</del>
9	ICE-55227	Gray	72" x 30" x 29"	77 lbs.	Each <del>274.95</del>
10	ICE-55224	Mahogany	72" x 30" x 29"	77 lbs.	Each <del>274.95</del>
11	ICE-55287	Gray	72" x 18" x 29"	46 lbs.	Each <del>259.95</del>
12	ICE-55284	Mahogany	72" x 18" x 29"	46 lbs.	Each <del>259.95</del>
13	ICE-55217	Gray	60" x 30" x 29"	56 lbs.	Each <del>261.95</del>
14	ICE-55214	Mahogany	60" x 30" x 29"	56 lbs.	Each <del>261.95</del>
15	ICE-55277	Gray	60" x 18" x 29"	39 lbs.	Each <del>239.95</del>
16	ICE-55274	Mahogany	60" x 18" x 29"	39 lbs.	Each <del>239.95</del>

### D PREMIUM WOOD LAMINATE ROUND FOLDING TABLE

Full perimeter steel skirt support. Melamine top supports up to 1,000 lbs. evenly distributed.

17	ICE-55267	Gray	60" dia. x 29"	88 lbs.	Each <del>429.95</del>
18	ICE-55264	Mahogany	60" dia. x 29"	88 lbs.	Each <del>429.95</del>

### E ECONOMY WOOD LAMINATE FOLDING TABLE

Quick to set-up and folds for easy storage. Wear-resistant 5/8" thick durable melamine top supports up to 300 lbs. evenly distributed.

<b>Curved Legs</b>					
19	ICE-55324	Walnut	72" x 30" x 29"	65 lbs.	Each <del>252.00</del>
20	ICE-55314	Walnut	60" x 30" x 29"	49 lbs.	Each <del>239.00</del>
<b>Straight Legs</b>					
21	ICE-55304	Walnut	48" x 24" x 29"	35 lbs.	Each <del>218.00</del>



## Great Service

We can help you with selection & solutions.

Prices subject to change without notice.

Visit our website for the latest pricing and product information.

# Tables Folding



## A - B WOOD FOLDING TABLES

Fully finished laminate on top and underside to prevent warping. Laminate is scratch-, dent- and water-resistant.

### A WOOD FOLDING TABLE

Fully finished laminate top and underside to prevent warping — lamination is scratch-, dent-, and water-resistant. Top is 5/8" thick with a one-piece, 1 3/4" steel apron and protective edge. Gravity leg-locking mechanism makes set-up quick and easy. Folds to 2 1/2" thick and locks for easy transport and storage. 1" diameter, steel legs have plastic foot caps to protect floors. Holds up to 1,200 lbs evenly distributed. Manufacturer's limited five-year warranty. Meets or Exceeds ANSI/BIFMA Standards.

ID No.	Color	W x D x H	Shpg. Wt.	Unit	Price
1 ALE-FT729630BK	Black	96" x 30" x 29"	78 lbs.	Each	<del>310.00</del>
2 ALE-FT729630MY	Mahogany	96" x 30" x 29"	78 lbs.	Each	<del>310.00</del>
3 ALE-FT727230BK	Black	72" x 30" x 29"	61 lbs.	Each	<del>250.00</del>
4 ALE-FT727230MY	Mahogany	72" x 30" x 29"	61 lbs.	Each	<del>250.00</del>
5 ALE-FT727218BK	Black	72" x 18" x 29"	42 lbs.	Each	<del>225.00</del>
6 ALE-FT727218MY	Mahogany	72" x 18" x 29"	42 lbs.	Each	<del>225.00</del>
7 ALE-FT726030BK	Black	60" x 30" x 29"	54 lbs.	Each	<del>235.00</del>
8 ALE-FT726030MY	Mahogany	60" x 30" x 29"	54 lbs.	Each	<del>235.00</del>
9 ALE-FT726018BK	Black	60" x 18" x 29"	38 lbs.	Each	<del>199.00</del>
10 ALE-FT726018MY	Mahogany	60" x 18" x 29"	38 lbs.	Each	<del>199.00</del>
11 ALE-FT724824BK	Black	48" x 24" x 29"	40 lbs.	Each	<del>225.00</del>
12 ALE-FT724824MY	Mahogany	48" x 24" x 29"	40 lbs.	Each	<del>225.00</del>

### B ROUND WOOD FOLDING TABLE

ID No.	Color	Size	Shpg. Wt.	Unit	Price
13 ALE-FT7260DMY	Mahogany	59" dia. x 29"	82 lbs.	Each	<del>450.00</del>



**Fast Delivery**

In most cases, the next business day!

## Grab a Seat



## Stacking Chairs

Stacks up to 12 high.

- Padded seat and back with vinyl upholstery.
- Four chairs per carton.
- Tubular steel structure with corrosion resistant powder coat finish is exceptionally strong.
- Plastic foot glides protect floors.
- Easy grab-and-go handle to position and stack with ease.
- Manufacturer's limited five-year warranty.
- Meets or exceeds ANSI/BIFMA Standards.

ID No.	Color	Shpg. Wt.	Qty.	Unit	Price
--------	-------	-----------	------	------	-------

### C VINYL STACKING CHAIRS

Supports up to 250 lbs. Seat: 15 3/4" x 15 3/4". Back: 13" x 12 3/4". Overall height: 32 1/2".

14 ALE-SC68VY10B	Black	67 lbs.	4	Carton	<del>565.00</del>
------------------	-------	---------	---	--------	-------------------

### D STACKING CHAIR DOLLY

Sturdy steel powder coated dolly with 3/4" raised edge keeps chairs from sliding off. Four casters. Holds 10-12 chairs. 22 1/2" x 22 1/2".

15 ALE-SCCART	Black	14 lbs.		Each	<del>99.00</del>
---------------	-------	---------	--	------	------------------





## IndestrucTable Top™ Tables

Contemporary design with smooth edges.

- Lightweight, durable and portable.
- Durable top is dent-, scratch-, stain-resistant and washes easily.
- Blow-molded high-density polyethylene top.
- Manufacturer's limited 15-year warranty.
- Contains 35% total recycled content.
- Meets or exceeds ANSI/BIFMA Standards.

ID No.	Color	W x D x H	Shpg. Wt.	Unit	Price
<b>A BI-FOLD RECTANGULAR</b> —Holds 2,000 lbs. evenly distributed.					
1	ICE-65467	Charcoal	72" x 30" x 29"	35 lbs.	Each <del>499.95</del>
2	ICE-65463	Platinum	72" x 30" x 29"	35 lbs.	Each <del>499.95</del>
Holds 350 lbs. evenly distributed. Convenient carrying handle.					
3	ICE-65457	Charcoal	60" x 30" x 29"	34 lbs.	Each <del>476.50</del>
4	ICE-65453	Platinum	60" x 30" x 29"	34 lbs.	Each <del>476.50</del>
<b>B HEAVY DUTY RECTANGULAR</b> —Holds 2,000 lbs. evenly distributed.					
5	ICE-65237	Charcoal	96" x 30" x 29"	52 lbs.	Each <del>406.95</del>
6	ICE-65233	Platinum	96" x 30" x 29"	52 lbs.	Each <del>406.95</del>
7	ICE-65227	Charcoal	72" x 30" x 29"	41 lbs.	Each <del>334.95</del>
8	ICE-65223	Platinum	72" x 30" x 29"	41 lbs.	Each <del>334.95</del>
9	ICE-65217	Charcoal	60" x 30" x 29"	40 lbs.	Each <del>299.95</del>
10	ICE-65213	Platinum	60" x 30" x 29"	40 lbs.	Each <del>299.95</del>

ID No.	Color	Size	Shpg. Wt.	Unit	Price
<b>C STANDARD DUTY RECTANGULAR</b> —Holds 600 lbs. evenly distributed.					
11	ICE-65387	Charcoal	72" x 24" x 29"	33 lbs.	Each <del>288.95</del>
12	ICE-65383	Platinum	72" x 24" x 29"	33 lbs.	Each <del>288.95</del>
13	ICE-65377	Charcoal	60" x 24" x 29"	30 lbs.	Each <del>248.95</del>
14	ICE-65373	Platinum	60" x 24" x 29"	30 lbs.	Each <del>248.95</del>
15	ICE-65207	Charcoal	48" x 24" x 29"	26 lbs.	Each <del>218.95</del>
16	ICE-65203	Platinum	48" x 24" x 29"	26 lbs.	Each <del>218.95</del>
<b>D STANDARD RECTANGULAR</b> —Holds up to 250 lbs. evenly distributed.					
17	ICE-65363	Platinum	72" x 18" x 29"	30 lbs.	Each <del>272.95</del>
18	ICE-65353	Platinum	60" x 18" x 29"	26 lbs.	Each <del>240.95</del>
<b>E SQUARE FOLDING TABLE</b> —Holds 600 lbs. evenly distributed.					
19	ICE-65273	Platinum	37" x 37" x 29"	31 lbs.	Each <del>484.95</del>
<b>F ROUND FOLDING TABLE</b> —Holds 600 lbs. evenly distributed.					
20	ICE-65267	Charcoal	60" dia. x 29"	59 lbs.	Each <del>336.95</del>
21	ICE-65263	Platinum	60" dia. x 29"	59 lbs.	Each <del>336.95</del>
22	ICE-65247	Charcoal	48" dia. x 29"	39 lbs.	Each <del>284.95</del>
23	ICE-65243	Platinum	48" dia. x 29"	39 lbs.	Each <del>284.95</del>
<b>G PERSONAL FOLDING TABLE</b> —Holds 25 lbs. evenly distributed.					
24	ICE-65491	Charcoal	30" x 20" x 28"	11 lbs.	Each <del>63.50</del>
25	ICE-65490	Platinum/Gray	30" x 20" x 28"	11 lbs.	Each <del>63.50</del>

Prices subject to change without notice. Visit our website for the latest pricing and product information.

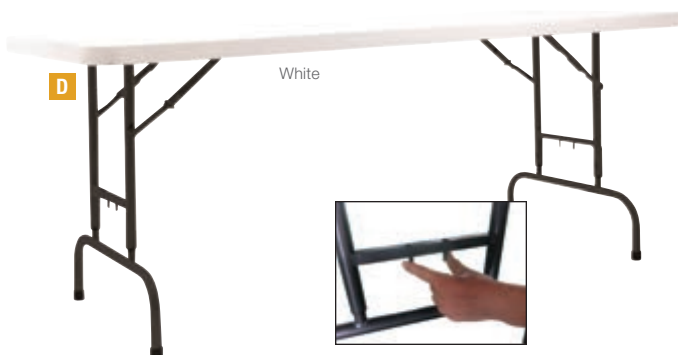

## Plastic Folding Table

Tables are perfect for both indoors or outdoors.

- Convenient rectangular folding tables set up quick when extra table/counter space is needed.
- Blow-molded polyethylene top is water and stain resistant; won't crack or stain.
- Strong durable powder-coated metal construction withstands dents and scratches.
- Slide lock feature to ensure table stability once opened.
- Folds flat for compact storage.
- Non-marring foot caps protect your floor from scratches.
- Manufacturer's limited five-year warranty.
- Meets or Exceeds ANSI/BIFMA Standards.

### A - B PLASTIC FOLDING TABLE

ID No.	Color	W x D x H	Shpg. Wt.	Unit	Price
<b>A RECTANGULAR PLASTIC FOLDING TABLE</b>					
<b>Supports up to 1,000 lbs. evenly distributed</b>					
1	ALE-PT9630G	Gray 96" x 30" x 29"	49 lbs.	Each	<del>295.00</del>
2	ALE-PT7230G	Gray 72" x 30" x 29"	37 lbs.	Each	<del>205.00</del>
3	ALE-PT6030G	Gray 60" x 30" x 29"	31 lbs.	Each	<del>160.00</del>
<b>Supports up to 400 lbs. evenly distributed</b>					
4	ALE-PT4824G	Gray 48" x 24" x 29"	23 lbs.	Each	<del>155.00</del>
<b>B SQUARE PLASTIC FOLDING TABLE</b>					
<b>Supports up to 600 lbs. evenly distributed.</b>					
5	ALE-PT36SW	White 36" x 36" x 29"	28 lbs.	Each	<del>150.00</del>

## Round Plastic Folding Table

Convenient round folding tables setup quick for banquets, dinner or when just extra space is needed.

- Blow-molded polyethylene top is water and stain resistant; won't crack or stain.
- Strong durable powder-coated metal construction withstands dents and scratches.
- Slide lock feature to ensure table stability once opened.
- Manufacturer's limited five-year warranty.
- Meets or Exceeds ANSI/BIFMA Standards.

### C ROUND PLASTIC FOLDING TABLE

Legs fold flush into table creating a flat surface for storage and stacking. Non-marring foot caps protect your floors from scratches. Resin top.

ID No.	Color	Size	Shpg. Wt.	Unit	Price
<b>Supports up to 900 lbs. evenly distributed</b>					
6	ALE-PT60RW	White 60" dia. x 29"	56 lbs.	Each	<del>320.00</del>
<b>Supports up to 800 lbs. evenly distributed</b>					
7	ALE-PT48RW	White 48" dia. x 29"	36 lbs.	Each	<del>250.00</del>

## Adjustable Height Plastic Folding Table

Go from table to counter height in snap.

- Easy grip and pull mechanism makes lifting or lowering a snap.
- 4 adjustment heights from table height to bistro height.
- Perfect for both indoors or outdoors.
- Blow-molded polyethylene top is water and stain resistant; won't crack or stain.
- Strong durable powder-coated metal construction withstands dents and scratches.
- Slide lock feature to ensure table stability once opened.
- Manufacturer's limited five-year warranty.
- Meets or Exceeds ANSI/BIFMA Standards.

### D ADJUSTABLE HEIGHT PLASTIC FOLDING TABLE

Legs fold flush into table creating a flat surface for storage and stacking. Non-marring foot caps. Resin top Supports up to 600 lbs. evenly distributed.

ID No.	Color	W x D x H	Shpg. Wt.	Unit	Price
8	ALE-PT72AHW	White 72" x 30" x 29" to 37"	45 lbs.	Each	<del>295.00</del>



### A RESIN BANQUET FOLDING TABLE

Tables for indoor and outdoor usage. Blow-molded, high-density polyethylene top is dent, scratch, stain and water resistant. Legs fold into underside cavity. Folds to 2" storage. Charcoal gray powder coated 1" steel tub legs with non-marring feet. Blow-Molded High-Density Polyethylene top. Square edge. Manufacturer's limited ten-year warranty. Contains 35% pre-consumer recycled content, 35% total recycled content.

ID No.	Color	Size	Shpg. Wt.	Unit	Price
<b>Banquet Tables</b> —Holds up to 1,000 lbs. evenly distributed.					
1	ALE-65601	Platinum	96" x 30" x 29"	49 lbs.	Each <del>299.00</del>
2	ALE-65600	Platinum	72" x 30" x 29"	36 lbs.	Each <del>195.00</del>
3	ALE-65602	Platinum	60" x 30" x 29"	31 lbs.	Each <del>175.00</del>
<b>Banquet Tables</b> —Holds up to 600 lbs. evenly distributed.					
4	ALE-65603	Platinum	48" x 24" x 29"	25 lbs.	Each <del>165.00</del>

\* ALE-65601, ALE-65600—Meets or exceeds ANSI/BIFMA Standards.

### B FOLD-IN-HALF RESIN FOLDING TABLE

Great for indoor and outdoor use. Conveniently folds in half for compact storage. Fold-away carrying handle. Gravity-leg locking mechanism for simple setup. Easy to clean, dent-, scratch- and stain-resistant resin top. Powder-coated steel frame. Steel tube legs. Non-marring rubber foot caps. Supports up to 400 lbs. evenly distributed. Manufacturer's limited five-year warranty. Meets or exceeds ANSI/BIFMA Standards.

ID No.	Color	Size	Shpg. Wt.	Unit	Price
5	ALE-FR72H	White	71" x 30" x 29¼"	29 lbs.	Each <del>235.00</del>
6	ALE-FR60H	White	60" x 30" x 29¼"	27 lbs.	Each <del>199.00</del>

### C CHAIR/TABLE CART

Adjustable to accommodate most styles of folding chairs/tables. Convenient steel construction cart can be used as both a folding chair cart or table cart. Adjustable U-bar keeps folding chairs from falling over during transport. U-bar is removable for table storage. Heavy-duty casters; two locking. Holds up to 600 lbs. Includes safety strap.

ID No.	Finish	W x D	Shpg. Wt.	Unit	Price
7	ALE-FTCART	Black	20¼" x 50¾" to 75¾"	65 lbs.	Each <del>555.00</del>

## Perfect casual seating



## Plastic Resin Folding Chairs

Molded plastic chairs are perfect for quick setups with large groups.

- Great for indoor and outdoor use.
- Contoured seat and back for maximum comfort.
- Powder coated steel frame resists corrosion and provides exceptional strength.
- Folds flat for compact storage.
- Non-marring foot caps protect surfaces.
- Manufacturer's limited five-year warranty.
- Meets or exceeds ANSI/BIFMA Standards.

### D PREMIUM MOLDED PLASTIC RESIN FOLDING CHAIR

Extra-duty folding chair for added strength and durability. Deluxe size delivers optimum support. Reliable for extended usage. Supports up to 250 lbs. Seat: 16" x 17 ¾". Back 17 ¾" x 10 ¼". Overall Height 33 ½"

ID No.	Color	Shpg. Wt.	Qty.	Unit	Price
8	ALE-FR9302	White/Dark Grey	51 lbs.	4	Carton <del>345.00</del>

### E MOLDED PLASTIC RESIN FOLDING CHAIR

Classic chair for all occasions. Supports up to 225 lbs. Seat: 15 ¾" x 16 ½". Back 17" x 8 ¾". Overall Height 31"

ID No.	Color	Shpg. Wt.	Qty.	Unit	Price
9	ALE-FR9402	White/Dark Grey	31 lbs.	4	Carton <del>295.00</del>

### F BANQUET PLASTIC RESIN FOLDING CHAIR

Lightweight and stackable. U-brace frame for stability. Supports up to 225 lbs. Seat: 15 ½" x 15 ½". Back 16 ½" x 6 ½". Overall Height 31"

ID No.	Color	Shpg. Wt.	Qty.	Unit	Price
10	ALE-FR9502	White	26 lbs.	4	Carton <del>175.00</del>

Prices subject to change without notice. Visit our website for the latest pricing and product information.

# Tables Hospitality

## Iceberg iLand Tables

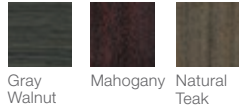

## iLand Table

**Durability with casual comfort and contemporary style.**

- Create ideal collaboration zones in cafes, common areas or conference meeting space.
- Permanently bonded seams between laminate and edge.
- Premium high-pressure 1 1/8" laminate top with molded PVC edge banding for enhanced durability.
- Elegant arched tubular steel-base design. Choose between seated or bistro height.
- Supports up to 225 lbs. evenly distributed.
- Base and top ship together in one box.
- Manufacturer's limited fifteen-year warranty.
- Meets or Exceeds ANSI/BIFMA Standards.

### A - C iLAND TABLES

ID No.	Color	Size	Shpg. Wt.	Unit	Price
<b>A CONTOUR EDGE SQUARE BISTRO STYLE</b>					
1	ICE-69757	Natural Teak	36" x 36" x 42"	56 lbs.	Each <del>599.95</del>
<b>B CONTOUR EDGE SQUARE SEATED STYLE</b>					
2	ICE-69764	Gray Walnut	42" x 42" x 42"	62 lbs.	Each <del>646.95</del>
3	ICE-69767	Natural Teak	42" x 42" x 42"	62 lbs.	Each <del>646.95</del>
4	ICE-69754	Gray Walnut	36" x 36" x 42"	56 lbs.	Each <del>599.95</del>
5	ICE-69744	Gray Walnut	42" x 42" x 29"	62 lbs.	Each <del>614.95</del>
6	ICE-69747	Natural Teak	42" x 42" x 29"	62 lbs.	Each <del>614.95</del>
7	ICE-69724	Gray Walnut	36" x 36" x 29"	56 lbs.	Each <del>561.95</del>
8	ICE-69727	Natural Teak	36" x 36" x 29"	56 lbs.	Each <del>561.95</del>
<b>C CONTOUR EDGE ROUND SEATED STYLE</b>					
9	ICE-69738	Mahogany	42" dia. x 29"	62 lbs.	Each <del>614.95</del>
10	ICE-69737	Natural Teak	42" dia. x 29"	62 lbs.	Each <del>614.95</del>
11	ICE-69718	Mahogany	36" dia. x 29"	56 lbs.	Each <del>561.95</del>
12	ICE-69717	Natural Teak	36" dia. x 29"	56 lbs.	Each <del>561.95</del>

## Iceberg CaféWorks Tables

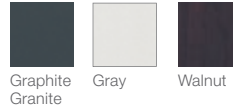

## CaféWorks Tables

**Inspire conversation and collaboration.**

- Contemporary curvilinear square top or round top.
- Wear-resistant 1 1/8" thick melamine top with vinyl T-mold edging.
- Melamine sealed top and underside resists spills, moisture, hot/cold temperatures and warping.
- Melamine laminate top supports up to 225 lbs. evenly distributed.
- Sturdy steel base with a durable powder coated finish.
- Adjustable feet help compensate for uneven flooring.
- Manufacturer's limited fifteen-year warranty.
- Meets or Exceeds ANSI/BIFMA Standards.

ID No.	Color	Size	Shpg. Wt.	Unit	Price
<b>D CAFÉ HEIGHT (30" HIGH) SQUARE</b>					
13	ICE-65618	Graphite Granite	36" x 36" x 30"	54 lbs.	Each <del>476.95</del>
14	ICE-65617	Gray	36" x 36" x 30"	54 lbs.	Each <del>476.95</del>
15	ICE-65614	Walnut	36" x 36" x 30"	54 lbs.	Each <del>476.95</del>
<b>E CAFÉ HEIGHT (30" HIGH) ROUND</b>					
16	ICE-65628	Graphite Granite	36" dia. x 30"	54 lbs.	Each <del>476.95</del>
17	ICE-65621	Gray	36" dia. x 30"	54 lbs.	Each <del>476.95</del>
18	ICE-65624	Walnut	36" dia. x 30"	54 lbs.	Each <del>474.95</del>

## CaféWorks Chairs

**Ergonomically designed for comfort and contemporary style.**

- Contemporary ergonomic design with seat pan and back constructed of blow molded high-density polyethylene.
- Dent- and scratch-resistant.
- Easy to clean.
- Heavy-gauge, 1" diameter powder-coated steel tube frame.
- Manufacturer's limited fifteen-year warranty.
- Contains 35% total recycled content.

ID No.	Seat/Back Color	Base Color	Shpg. Wt.	Qty.	Unit	Price
<b>F CAFÉ CHAIR</b>						
Two chairs per carton. Supports up to 225 lbs. Seat: 17.5" x 18.5". Back: 18" x 9". Overall height: 32".						
19	ICE-64517	Graphite/Graphite	Silver	30 lbs.	2 Carton	<del>979.95</del>





## Between™ Table Tops

Perfect for a variety of areas throughout your office...meeting rooms, breakrooms, cafes or breakaway spaces that support today's agile workforce.

- Standing and seated-height options.
- Durable scratch-resistant laminate.
- Between™ Table Tops easily attach to bases.
- Backed by the HON Full Lifetime Warranty.
- Meets or Exceeds ANSI/BIFMA Standards.

Tops and Base sold and shipped separately—ORDER BOTH.

### A ROUND TABLE TOPS

ID No.	Color	Size	Shpg. Wt.	Unit	Price
1 HON-BTRND42NCC	Harvest	42"	57 lbs.	Each	<del>401.00</del>
2 HON-BTRND42NDD	Natural Maple	42"	57 lbs.	Each	<del>401.00</del>
3 HON-BTRND42NA9S	Steel Mesh/Charcoal	42"	57 lbs.	Each	<del>401.00</del>
4 HON-BTRND36NCC	Harvest	36"	44 lbs.	Each	<del>330.00</del>
5 HON-BTRND36NDD	Natural Maple	36"	44 lbs.	Each	<del>330.00</del>
6 HON-BTRND36NA9S	Steel Mesh/Charcoal	36"	44 lbs.	Each	<del>330.00</del>
7 HON-BTRND30NCC	Harvest	30"	31 lbs.	Each	<del>310.00</del>
8 HON-BTRND30NDD	Natural Maple	30"	31 lbs.	Each	<del>310.00</del>
9 HON-BTRND30NA9S	Steel Mesh/Charcoal	30"	31 lbs.	Each	<del>310.00</del>

## Between™ Table Bases

Lightweight bases make movement throughout your space a breeze.

- Cast aluminum bases provide a sturdy foundation and attach easily to Between™ table top through pre-drilled holes.
- Leveling glides adjust to compensate for uneven floors.
- Available in various finishes to match virtually any surrounding aesthetic.
- Backed by the HON Limited Five-Year Warranty.

Tops and Base sold and shipped separately—ORDER BOTH.

### B ROUND DISC SEATED HEIGHT BASES

ID No.	Height	Color	Shpg. Wt.	Unit	Price
<b>For 42" Table Tops</b>					
10 HON-HBTTD42P6P	42"	Black	47 lbs.	Each	<del>410.00</del>
11 HON-HBTTD42	42"	Silver	47 lbs.	Each	<del>410.00</del>
<b>For 30"-36" Table Tops</b>					
12 HON-HBTTD30P6P	29"	Black	24 lbs.	Each	<del>355.00</del>
13 HON-HBTTD30	29"	Silver	24 lbs.	Each	<del>355.00</del>

### C SEATED HEIGHT X-BASES

ID No.	Height	Color	Shpg. Wt.	Unit	Price
<b>For 42" Table Tops</b>					
14 HON-BTX30LP6P	29.57"	Black	29 lbs.	Each	<del>437.00</del>
15 HON-BTX30LPR8	29.57"	Silver	29 lbs.	Each	<del>437.00</del>
<b>For 30-36" Table Tops</b>					
16 HON-BTX30SP6P	29.57"	Black	27 lbs.	Each	<del>298.00</del>
17 HON-BTX30SPR8	29.57"	Silver	27 lbs.	Each	<del>298.00</del>

### D CAFE HEIGHT X-BASES

ID No.	Height	Color	Shpg. Wt.	Unit	Price
<b>For 42" Table Tops</b>					
18 HON-BTX42LP6P	41.12"	Black	34 lbs.	Each	<del>500.00</del>
19 HON-BTX42LPR8	41.12"	Silver	34 lbs.	Each	<del>500.00</del>
<b>For 30-36" Table Tops</b>					
20 HON-BTX42SP6P	41.12"	Black	30 lbs.	Each	<del>359.00</del>
21 HON-BTX42SPR8	41.12"	Silver	30 lbs.	Each	<del>359.00</del>



#### Top Colors

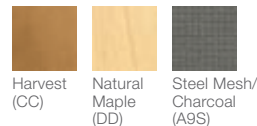

#### Base Colors

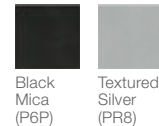

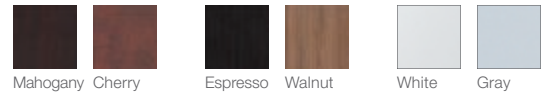
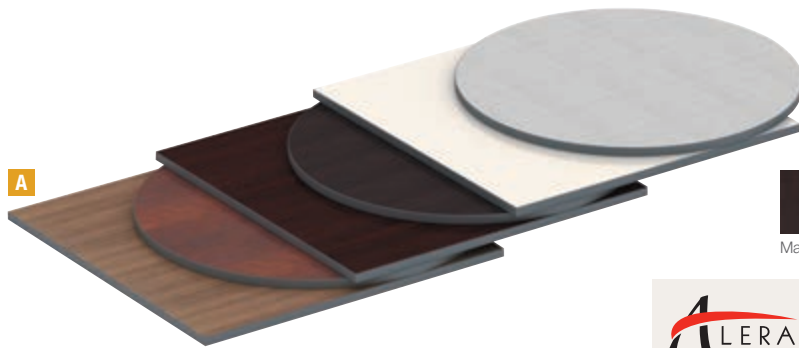

## Reversible Laminate Table Tops

Take your pick. Multiple sizes and colors to create your own unique desk, table or workstation.

- Reversible table tops have a different color and pattern on each side with coordinating dark gray edge banding.
- Use with Alera® bases to create height adjustable workstations, training tables, collaborative spaces or standard desks.
- Durable laminate is water-, scratch-, and dent-resistant.
- Coordinating colors with Alera® Valencia™ and Open Office Suites.
- Commercial grade, 1" thick top.
- Manufacturer's limited five-year warranty.
- Meets or Exceeds ANSI/BIFMA Standards.

Tops and Base sold separately—ORDER BOTH.

### A REVERSIBLE TABLE TOP

ID No.	Color	W x D	Shpg. Wt.	Unit	Price
<b>Square</b>					
1	ALE-TTSQ36EW	Espresso/Walnut	35½" x 35½"	37 lbs.	Each <del>475.00</del>
2	ALE-TTSQ36CM	Medium Cherry/Mahogany	35½" x 35½"	37 lbs.	Each <del>475.00</del>
3	ALE-TTSQ36WG	White/Gray	35½" x 35½"	37 lbs.	Each <del>475.00</del>
<b>Round</b>					
4	ALE-TTRD36EW	Espresso/Walnut	35½" dia.	29 lbs.	Each <del>475.00</del>
5	ALE-TTRD36CM	Medium Cherry/Mahogany	35½" dia.	29 lbs.	Each <del>475.00</del>
6	ALE-TTRD36WG	White/Gray	35½" dia.	30 lbs.	Each <del>475.00</del>

### B HOSPITALITY SERIES SINGLE-COLUMN BASES

Classic table base works great to create hospitality, meeting, conference or quick-huddle setups. Reinforced weighted steel base for enhanced stability and durability. X-shape design provides plenty of room to pull up chairs/stools. Leveling glides help to compensate for uneven floors. Manufacturer's limited five-year warranty.

ID No.	Height	Color	Shpg. Wt.	Unit	Price
<b>Bistro—Standing height.</b>					
7	ALE-TBH423B	40½"	Black	29 lbs.	Each <del>299.00</del>
<b>Standard—Sitting height.</b>					
8	ALE-TBH283B	28½"	Black	26 lbs.	Each <del>259.00</del>

### C STAINLESS STEEL FOODSERVICE PREP TABLE

A great work surface for any area. The corrosive-resistant, heat-resistant T430 top is National Sanitation Foundation approved for use with food, has a 2" rooked edge, and its surface is easy to clean, even after the dirtiest jobs. Two "C" channels under the top provide additional strength, preventing the table from sagging over time. The lower shelf is height-adjustable, giving the user the flexibility they need for a variety of tasks. 18-gauge stainless steel top; galvanized steel base and shelf. Stainless Steel top Supports up to 800 lbs. evenly distributed. Manufacturer's limited five-year warranty.

ID No.	Color	Size	Shpg. Wt.	Unit	Price
9	ALE-XS7230	Silver	72" x 30" x 35"	94 lbs.	Each <del>625.00</del>
10	ALE-XS6030	Silver	60" x 30" x 35"	82 lbs.	Each <del>570.00</del>
11	ALE-XS4830	Silver	48" x 30" x 35"	69 lbs.	Each <del>490.00</del>
12	ALE-XS3630	Silver	36" x 30" x 35"	56 lbs.	Each <del>465.00</del>





## CoGo™ Table

Versatile and highly functional.

- Ideal for outdoor use and easily adaptable for indoor use.
- UV- and weather-resistant steel construction.
- Opening on tabletop accommodates an umbrella (not included).
- Underside hooks for purses, backpacks, jackets and other belongings.
- Powder-coat finish.
- Supports up to 250 lbs. evenly distributed.
- Manufacturer's limited lifetime warranty.
- GREENGUARD Certified.

### CoGo™ Series

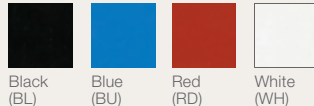

### Entourage Series



## Entourage™ Tables

Ideal for outdoors.

- The top surface and edge are seamless to keep moisture out.
- Table is UV-, heat- and scratch-resistant making it a perfect addition to outdoor meeting spaces, patios or break areas.
- Powder coated steel base features a silver finish.
- Manufacturer's limited lifetime warranty.

Top and Base sold and shipped separately—ORDER BOTH.

### A COGO™ TABLE

ID No.	Color	Size	Shpg. Wt.	Unit	Price
1 SAF-4362BL	Black	36" dia. × 29½"	59 lbs.	Each	<del>369.00</del>
2 SAF-4362BU	Blue	36" dia. × 29½"	59 lbs.	Each	<del>369.00</del>
3 SAF-4362RD	Red	36" dia. × 29½"	59 lbs.	Each	<del>369.00</del>
4 SAF-4362WH	White	36" dia. × 29½"	59 lbs.	Each	<del>369.00</del>
5 SAF-4361BL	Black	30" dia. × 29½"	49 lbs.	Each	<del>316.00</del>
6 SAF-4361BU	Blue	30" dia. × 29½"	49 lbs.	Each	<del>316.00</del>
7 SAF-4361RD	Red	30" dia. × 29½"	49 lbs.	Each	<del>316.00</del>
8 SAF-4361WH	White	30" dia. × 29½"	49 lbs.	Each	<del>316.00</del>

### C TABLE BASE

ID No.	Height	Color	Shpg. Wt.	Unit	Price
13 SAF-2490SL	29"	Silver	22 lbs.	Each	<del>278.00</del>

### D TABLE TOPS

ID No.	Color	Size	Shpg. Wt.	Unit	Price
14 SAF-2492AC	Anthracite	32"	18 lbs.	Each	<del>229.00</del>
15 SAF-2491AC	Anthracite	24"	12 lbs.	Each	<del>167.00</del>

## CoGo™ Steel Outdoor/Indoor Stack Chairs

Multipurpose stacking metal chair for outdoor or indoor use.

- Tubular steel construction with scratch-resistant powder-coat finish.
- Outdoor rated for UV protection.
- Repellent against moisture, heat and stains.
- Curved back rest for comfort.
- Durable nylon glides on feet guard against scratching or marring.
- Chairs stack up to eight high.
- Manufacturer's limited lifetime warranty.
- GREENGUARD Certified.

### B COGO™ STEEL OUTDOOR/INDOOR STACK CHAIR

Supports up to 250 lbs. Seat: 16½" × 16". Back: 21" × 11¼". Overall height: 28¾".

ID No.	Seat/Back Color	Base Color	Shpg. Wt.	Qty.	Unit	Price
9 SAF-4360BL	Black	Black	40 lbs.	2	Carton	<del>358.00</del>
10 SAF-4360BU	Blue	Blue	40 lbs.	2	Carton	<del>358.00</del>
11 SAF-4360RD	Red	Red	40 lbs.	2	Carton	<del>358.00</del>
12 SAF-4360WH	White	White	40 lbs.	2	Carton	<del>358.00</del>

## Entourage™ Stack Chair

- UV-rated making them a perfect addition to outdoor meeting spaces, patios or break areas.
- Manufacturer's limited lifetime warranty.
- GREENGUARD Certified.

### E STACK CHAIR

Constructed of one-piece solid molded resin. Features a curved seat for comfort and contoured seat pan. Chairs easily stack up to eight high when not needed. Outdoor rated for UV. Supports up to 250 lbs. Seat: 17" × 18". Back: 19½" × 14". Overall height: 30".

ID No.	Seat/Back Color	Base Color	Shpg. Wt.	Qty.	Unit	Price
16 SAF-4359GS	Grass	Grass	54 lbs.	4	Carton	<del>600.00</del>
17 SAF-4359GR	Gray	Gray	54 lbs.	4	Carton	<del>600.00</del>
18 SAF-4359WH	White	White	54 lbs.	4	Carton	<del>600.00</del>

Prices subject to change without notice. Visit our website for the latest pricing and product information.

# Tables Picnic & Folding



A

Platinum/  
Gray



B

Mahogany



B

Black  
(BK)



C

Mahogany  
(MY)



## A PICNIC TABLE

Ideal for indoor and outdoor break areas or parks. Sturdy and weather resistant, designed to last for years. Won't fade or crack in sunlight. Seats six to eight people. Each bench and top holds up to 600 lbs. evenly distributed.

ID No.	Color	Size	Shpg. Wt.	Unit	Price
1 ICE-65923	Platinum/Gray	72" x 30" x 29"	82 lbs.	Each	<del>671.95</del>

Get a perfect fit



## STRETCH-FABRIC TABLE COVER

Easily transform resin- or laminate-wood-top tables into elegant presentation platforms in seconds. Table cloth fits snug over the table for a tailored fit, and reinforced leg-pockets keep the table cloth secured to the table while preventing tears and rips. Machine washable and iron safe. 90% polyester; 10% spandex. Manufacturer's limited five-year warranty.

ID No.	Size	Color	Materials	Qty.	Unit	Price
2 ICE-16531	30" x 96"	Black	Polyester/Spandex	1	Each	<del>43.45</del>
3 ICE-16521	30" x 72"	Black	Polyester/Spandex	1	Each	<del>36.45</del>
4 ICE-16526	30" x 72"	Blue	Polyester/Spandex	1	Each	<del>36.45</del>
5 ICE-16511	24" x 48"	Black	Polyester/Spandex	1	Each	<del>27.45</del>
<b>Open Design</b> —Allows for full seating at the table with spacious leg room.						
6 ICE-16541	30" x 72"	Black	Polyester/Spandex	1	Each	<del>38.45</del>
7 ICE-16546	30" x 72"	Blue	Polyester/Spandex	1	Each	<del>38.45</del>



## B - C WOOD FOLDING TABLES

Fully finished laminate on top and underside to prevent warping. Laminate is scratch-, dent- and water-resistant.

## B WOOD FOLDING TABLE

Fully finished laminate top and underside to prevent warping — lamination is scratch-, dent-, and water-resistant. Top is 3/8" thick with a one-piece, 1 3/4" steel apron and protective edge. Gravity leg-locking mechanism makes set-up quick and easy. Folds to 2 1/2" thick and locks for easy transport and storage. 1" diameter, steel legs have plastic foot caps to protect floors. Holds up to 1,200 lbs evenly distributed. Manufacturer's limited five-year warranty. Meets or Exceeds ANSI/ BIFMA Standards.

ID No.	Color	W x D x H	Shpg. Wt.	Unit	Price
8 ALE-FT729630BK	Black	96" x 30" x 29"	78 lbs.	Each	<del>310.00</del>
9 ALE-FT729630MY	Mahogany	96" x 30" x 29"	78 lbs.	Each	<del>310.00</del>
10 ALE-FT727230BK	Black	72" x 30" x 29"	61 lbs.	Each	<del>250.00</del>
11 ALE-FT727230MY	Mahogany	72" x 30" x 29"	61 lbs.	Each	<del>250.00</del>
12 ALE-FT727218BK	Black	72" x 18" x 29"	42 lbs.	Each	<del>225.00</del>
13 ALE-FT727218MY	Mahogany	72" x 18" x 29"	42 lbs.	Each	<del>225.00</del>
14 ALE-FT726030BK	Black	60" x 30" x 29"	54 lbs.	Each	<del>235.00</del>
15 ALE-FT726030MY	Mahogany	60" x 30" x 29"	54 lbs.	Each	<del>235.00</del>
16 ALE-FT726018BK	Black	60" x 18" x 29"	38 lbs.	Each	<del>199.00</del>
17 ALE-FT726018MY	Mahogany	60" x 18" x 29"	38 lbs.	Each	<del>199.00</del>
18 ALE-FT724824BK	Black	48" x 24" x 29"	40 lbs.	Each	<del>225.00</del>
19 ALE-FT724824MY	Mahogany	48" x 24" x 29"	40 lbs.	Each	<del>225.00</del>

## C ROUND WOOD FOLDING TABLE

ID No.	Color	Size	Shpg. Wt.	Unit	Price
20 ALE-FT7260DMY	Mahogany	59" dia. x 29"	82 lbs.	Each	<del>450.00</del>



# Office Furnishings

Complete your space with these all-important accessories.



Archival Filing & Storage	225
Art & Drafting/Tables & Files	226-227
Boards/Dry Erase, Porcelain	228-260
Cleaning & Sanitation/Brooms	261-262
Carts/Media & Beverage	263-265
Cleaning & Sanitation/ Cleaning Products	266-268
Clocks	269-270
Coat Racks & Hangers	271-274
Glue & Adhesive/ Mounting Products	275-276
Desk Accessories	277-281
Fans	282-283
File Folders/Hanging	284-285
Fire Protection	286
First Aid	287-289
Floor Mats & Wipers	290-295
Frames	296-297
Hand Carts & Trucks	298-299
Heaters	300-301
Lamps & Lighting	302-305
Lecterns	306
Literature Racks & Displays/Floor	307-310
Mail Carts	311
Paper Towel & Dispensers/ Restroom Supplies	312-324
Portable Files	325-326
Power/Surge Protectors	327-328
Refrigerators	329
Stands & Carts/ Computer & Monitor	330-333
Signs	334-335
Step Stools	336
Tools/General	337
Utility Carts	338-339
Vacuums	340
Waste Can Liners	341-344
Waste Receptacles	345-350



**These are the key pieces** that keep your business running smoothly. Essentials like whiteboards and signs to get your message across. Carts and trucks to keep your business rolling along. Smart ways to organize everything from magazines to garments to mail. From waste receptacles to floor mats and more, these are the tools that help you create a finely-tuned workplace.

# We're more

than exceptional seating and desks



- Computer furniture
- Sit-to-stand work solutions
- Ergonomic designs



- Office filing
- Storage cabinets
- Wire shelving
- Industrial shelving



- Hospitality and work tables
- Training tables



- Reception area and meeting room furniture

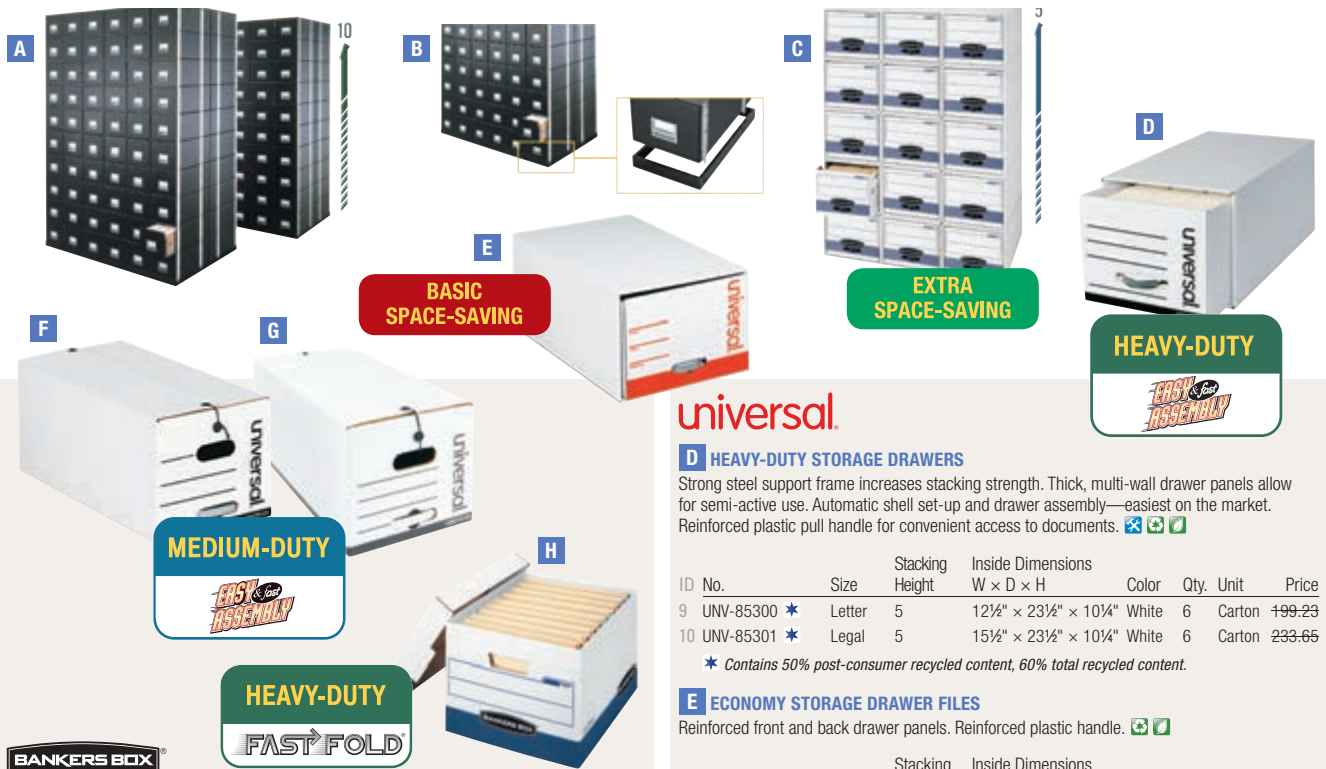

## A STAXONSTEEL® MAXIMUM SPACE-SAVING STORAGE DRAWERS

Stacks ten high. Store 80% more records in the same floor space. Steel framework interlocks vertically and horizontally to withstand the heaviest day-to-day usage. Our strongest system is also the easiest to assemble. Drawers snap together with poly-lock technology and are reinforced with steel wire. Steel frame and reinforced panels ensure drawers fully open and close smoothly. Factory installed, high-impact drawer handle with index card holder for fast file retrieval (index cards included).

ID No.	Size	Stacking Height	Inside Dimensions W × D × H	Color	Qty.	Unit	Price
1 FEL-00511 ★	Letter	10	12" × 24" × 10.5"	Black	6	Carton	352.29
2 FEL-00512 ★	Legal	10	15" × 24" × 10.5"	Black	6	Carton	383.22

★ Contains 75% post-consumer recycled content, 85% total recycled content recycled content.

## B METAL BASE

Protects files by raising them 2½" above floor level. Helps prevent damage from kicks, cleaning equipment and moisture.

ID No.	Size	Dimensions W × D × H	Unit	Price
3 FEL-12602	Letter	13¾" × 25¾" × 2½"	Each	45.64
4 FEL-15602	Legal	16¾" × 25¾" × 2½"	Each	46.99

## C STOR/DRAWER® STEEL PLUS™ EXTRA SPACE-SAVINGS STORAGE DRAWERS

Drawers stack five high—the higher the drawer system stacks, the more space, time and money you save. Heavy wire frame provides strength and stability. Four-layer drawer front and back panel construction hold up to daily usage. Includes removable rails for hanging files. Reinforced plastic handle for easy drawer access.

ID No.	Size	Stacking Height	Inside Dimensions W × D × H	Color	Qty.	Unit	Price
5 FEL-00302 ★	Check	5	9¼" × 23¼" × 4¾"	White/Blue	12	Carton	421.29

**With Steel Support Frame**—Includes removable hanging file rails.

6 FEL-00311 ★	Letter	5	12½" × 23¼" × 10¾"	White/Blue	6	Carton	251.49
7 FEL-1231101 ★	Letter	5	12½" × 23¼" × 10¾"	Kraft/Green	6	Carton	276.48
8 FEL-00312 ★	Legal	5	15½" × 23¼" × 10¾"	White/Blue	6	Carton	296.22

★ FEL-00302, FEL-00311, FEL-00312—Contains 50% post-consumer recycled content, 60% total recycled content.

FEL-1231101—Contains 100% total recycled content.

## universal.

### D HEAVY-DUTY STORAGE DRAWERS

Strong steel support frame increases stacking strength. Thick, multi-wall drawer panels allow for semi-active use. Automatic shell set-up and drawer assembly—easiest on the market. Reinforced plastic pull handle for convenient access to documents.

ID No.	Size	Stacking Height	Inside Dimensions W × D × H	Color	Qty.	Unit	Price
9 UNV-85300 ★	Letter	5	12½" × 23¼" × 10¼"	White	6	Carton	199.29
10 UNV-85301 ★	Legal	5	15½" × 23¼" × 10¼"	White	6	Carton	233.65

★ Contains 50% post-consumer recycled content, 60% total recycled content.

### E ECONOMY STORAGE DRAWER FILES

Reinforced front and back drawer panels. Reinforced plastic handle.

ID No.	Size	Stacking Height	Inside Dimensions W × D × H	Color	Qty.	Unit	Price
11 UNV-85120 ★	Letter	2	12½" × 23¼" × 10¾"	White	6	Carton	194.82
12 UNV-85220 ★	Legal	2	15½" × 23¼" × 10¾"	White	6	Carton	223.67

★ Contains 50% post-consumer recycled content, 60% total recycled content.

### F QUICK SET-UP STRING-AND-BUTTON BOXES

Sturdy corrugated construction for strength and value.

ID No.	Size	Stacking Strength	Dimensions W × D × H	Color	Qty.	Unit	Price
13 UNV-75121 ★	Letter	510 lbs	12" × 24" × 10"	White	12	Carton	473.02
14 UNV-75131 ★	Legal	580 lbs	15" × 24" × 10"	White	12	Carton	489.79

★ Stacking Strength is the amount of evenly distributed weight (lbs.) that can be safely stacked on top of a box. Contains 50% post-consumer recycled content, 60% total recycled content.

### G ECONOMICAL EASY ASSEMBLY STORAGE FILES

Features heavy-duty construction for lasting box strength. Works with or without shelving for versatile storage. Secure string and button closure keeps documents dust/dirt free.

ID No.	Size	Stacking Strength	Dimensions W × D × H	Color	Qty.	Unit	Price
15 UNV-75120 ★	Letter	375 lbs	12" × 24" × 10"	White	12	Carton	495.38
16 UNV-75130 ★	Legal	400 lbs	15" × 24" × 10"	White	12	Carton	234.46

★ Stacking Strength is the amount of evenly distributed weight (lbs.) that can be safely stacked on top of a box. Contains 50% post-consumer recycled content, 60% total recycled content.

## BANKERS BOX®

### H STOR/FILE™ END TAB STORAGE BOXES

Ideal for archiving and storing end tab letter/legal patient files. Heavy duty, triple end, double side, double bottom construction stacks up stronger and withstands frequent handling. FastFold® quick and easy assembly. Reinforced tear-resistant handles make box comfortable to carry. Deep, locking lift-off lid stays in place for secure file storage.

ID No.	Size	Stacking Strength	Dimensions W × D × H	Color	Qty.	Unit	Price
17 FEL-00709 ★	Letter/ Legal End Tab	850 lbs	12¾" × 15" × 10"	White/ Blue	12	Carton	204.24

★ Stacking Strength is the amount of evenly distributed weight (lbs.) that can be safely stacked on top of a box. Contains 50% post-consumer recycled content, 60% total recycled content.

Prices subject to change without notice.

Visit our website for the latest pricing and product information.



# Office Furnishings Art & Drafting/Tables & Files



## A PRECISION DRAFTING TABLE TOP

Sturdy 1" thick green, laminate top with smooth edges. Nonglare finish may help reduce eyestrain and fatigue. Wide design handles large format papers. Top and Base sold and shipped separately—ORDER BOTH. 📦 🚚

ID No.	Color	W × D	Shpg. Wt.	Unit	Price
1 SAF-3953 ★	Green	72" × 37½"	95 lbs.	Each	622.00
2 SAF-3952 ★	Green	60" × 37½"	77 lbs.	Each	468.00

★ Top and Base sold and shipped separately—ORDER BOTH.  
SAF-3962GR—GREENGUARD Certified.

## B PRECISION FOUR-POST DRAFTING TABLE BASE

Work in comfort with this height-adjustable drafting table. Heavy-gauge 4-post steel base with stabilizing bars. Easily adjust the board up to a 50° angle with no tools. For use with Safco® Precision Drafting Tabletops. 📦 🚚

No.	Color	W × D × H	Shpg. Wt.	Unit	Price
3 SAF-3962GR ★	Gray	56½" × 30½" × 35½"	99 lbs.	Each	973.00

★ GREENGUARD Certified. Top and Base sold and shipped separately—ORDER BOTH.

## C VERVE™ STANDING DESK

Pairs well with leaning or perch seating to help reduce fatigue from standing while still maintaining a more active and engaging posture. Standing height helps promote a more active working environment and may help promote additional calorie burn and increased focus over sitting. 📦 🚚

ID No.	Color	W × D × H	Shpg. Wt.	Unit	Price
4 SAF-1959WL	Walnut	47¼" × 31¾" × 42"	63 lbs.	Each	688.00
5 SAF-1959WH	White	47¼" × 31¾" × 42"	63 lbs.	Each	688.00

## D LAMINATE MOBILE ROLL FILES

"Grandstand" design holds various length rolls at graduated heights. Sturdy wood-core with vinyl laminate finish. 📦 🚚

ID No.	Bins	Bin W × D	W × D × H	Color	Unit	Price
6 SAF-3083 ★	50	2¾ × 2¾	30¼" × 15¾" × 29¼"	Putty	Each	512.00
7 SAF-3082 ★	20	2¾ × 2¾	15¼" × 13¼" × 23¼"	Putty	Each	288.00
8 SAF-3045 ★	8	7 × 7	30¼" × 15¾" × 29¼"	Putty	Each	461.00

★ Contains 80% total recycled content.

## E WIRE ROLL FILES

Roll Files hold and transport documents. Dust guard on bottom keeps materials clean and protects edges. Heavy-gauge steel with plastic coating. 📦 🚚

ID No.	Bins	Bin W × D	W × D × H	Color	Unit	Price
9 SAF-3088 ★	24	3¼ × 3¼	21" × 14¼" × 31¾"	White	Each	202.00
10 SAF-3084 ★	4	8 × 8	16¼" × 16½" × 30½"	White	Each	190.00

★ GREENGUARD Certified.

## F WIRE ROLL/FILE®

Tubular steel frame with chrome-plated grids. 📦 🚚

ID No.	Bins	Bin W × D	W × D × H	Color	Unit	Price
11 SAF-3091 ★	20	2¾ × 2¾	18" × 12¾" × 24½"	Gray	Each	155.00
12 SAF-3090 ★	12	3¾ × 3¾	18" × 12¾" × 24½"	Gray	Each	153.00

★ GREENGUARD Certified.





## A TUBE-STOR® FIBERBOARD FILES

Keep your rolled documents safe and available for quick retrieval. Wood side panels complement corrugated fiberboard to provide added strength on these stackable units. Inside flap features index grid. Depth adjusters allow you to store rolls up to 36" long. Includes Velcro® fasteners. Two file containers per carton.

ID No.	Bins	Bin Size	Inside Dimensions W x D x H	Color	Qty.	Unit	Price
1 SAF-3094 ★	18	3¾"	23½" x 37" x 11½"	White	2	Carton	296.00

★ GREENGUARD Certified.

## B CORRUGATED ROLL FILES

Shorter rolls store in front, longer rolls in back, all visible. Corrugated fiberboard.

ID No.	Bins	Bin W x D	W x D x H	Color	Unit	Price
2 SAF-3081 ★	20	2¾ x 2¾	15" x 12" x 22"	Woodgrain	Each	99.00
3 SAF-3079 ★	12	3¾ x 3¾	15" x 12" x 22"	Woodgrain	Each	93.00

★ Contains 100% post-consumer recycled content, 100% total recycled content.

## C SHEET FILE HANGING CLAMPS

Presentation and filing is easy with the strength and clever design of these hanging clamps. Aluminum clamps with black nylon wing knobs provide balanced gripping tension. Six clamps per carton. Manufacturer's limited lifetime warranty.

ID No.	Holds	Clamp Length	Width	Unit	Price
4 SAF-50016 ★	100 Sheets Per Clamp	18"	19¾"	Carton	318.00
5 SAF-50026 ★	100 Sheets Per Clamp	24"	25¼"	Carton	354.00
6 SAF-50036 ★	100 Sheets Per Clamp	30"	31¼"	Carton	396.00
7 SAF-50046 ★	100 Sheets Per Clamp	36"	37¾"	Carton	420.00
8 SAF-50056 ★	100 Sheets Per Clamp	42"	43¾"	Carton	444.00

★ GREENGUARD Certified.

## D STEEL SHEET FILE MOBILE STAND

Holds hanging clamps in pivot brackets for easy access. Base extends forward from 27½" to 37½". Height adjusts from 43½" to 61½". Large design supports up to 1,200 sheets in 12 hanging clamps (sold separately). Four 3" casters, two locking.

ID No.	Holds	W x D x H	Color	Unit	Price
9 SAF-5026 ★	12 Hanging Clamps	27" x 27½" to 37½" x 43½" to 61½"	Sand	Each	996.00

★ GREENGUARD Certified.

## E SHEET FILE MOBILE PLAN CENTER

Keep files accessible in this easy rolling storage unit. Large steel rack supports up to 1,800 sheets in 18 hanging clamps (sold separately). Adjusts to fit 25¾" to 43¾" clamps to meet your filing needs. Four 2" casters, two locking. Manufacturer's limited lifetime warranty.

ID No.	Holds	W x D x H	Color	Unit	Price
10 SAF-5060 ★	18 Hanging Clamps	25¾" to 43¾" x 20½" x 51"	Sand	Each	747.00

★ GREENGUARD Certified.

## F SHEET FILE PIVOT WALL RACK

Steel rack mounts on wall to accommodate any length sheets. Quick-reference brackets pivot for access to files. Includes mounting hardware. Holds up to 1,200 sheets in 12 hanging clamps (sold separately). Manufacturer's limited lifetime warranty.

ID No.	Holds	W x D x H	Color	Unit	Price
11 SAF-5016 ★	12 Hanging Clamps	24" x 14¾" x 9¾"	Sand	Each	439.00

★ GREENGUARD Certified.

## G SHEET FILE DROP/LIFT WALL RACK

Steel rack extends less than 12" from wall, yet holds up to 1,200 sheets in 12 hanging clamps (sold separately). Includes mounting hardware. Manufacturer's limited lifetime warranty.

ID No.	Holds	W x D x H	Color	Unit	Price
12 SAF-5030 ★	12 Hanging Clamps	19" to 43¾" x 11½" x 7¾"	Sand	Each	92.00

★ GREENGUARD Certified.

## Safely transport drawings



## TELESCOPING DOCUMENT TUBES

Protects documents, drawings and artwork. Tough plastic tube with screw-on end cap expands from 24½" to 40" long. Locking tabs in ¾" increments. Adjustable shoulder strap. Clear plastic end cap contains identification label.

ID No.	Inside Length	Inside Diameter	Qty.	Unit	Price
13 SAF-3053 ★	24.5" to 40"	3.5"	1	Each	44.00

★ GREENGUARD Certified.

Prices subject to change without notice.  
Visit our website for the latest pricing and product information.

# Office Furnishings Boards/Dry Erase, Porcelain



Use the PLUS MTG Sync App on your phone to clearly save your meeting notes.



## A PRESTIGE® 2 DURAMAX® MAGNETIC PORCELAIN

Durable whiteboard's magnetic, porcelain surface will not ghost, stain, scratch or dent. Includes four dry-erase markers, two magnets, accessory tray and mounting kit.

ID No.	W x H	Frame Color	Shpg. Wt.	Unit	Price
1 QRT-P554BP2 *	48" x 36"	Black	26 lbs.	Each	503.45
2 QRT-P554MP2 *	48" x 36"	Mahogany	26 lbs.	Each	503.45
3 QRT-P554AP2 *	48" x 36"	Silver	27 lbs.	Each	503.45
4 QRT-P557GP2 *	72" x 48"	Graphite	57 lbs.	Each	962.46
5 QRT-P557MP2 *	72" x 48"	Mahogany	55 lbs.	Each	962.46
6 QRT-P557AP2 *	72" x 48"	Silver	56 lbs.	Each	962.46
7 QRT-P558BP2 *	96" x 48"	Black	73 lbs.	Each	1,164.54
8 QRT-P558GP2 *	96" x 48"	Graphite	74 lbs.	Each	1,164.54
9 QRT-P558MP2 *	96" x 48"	Mahogany	74 lbs.	Each	1,164.54

\* Cradle to Cradle Certified™ Silver.

## B CLASSIC SERIES PORCELAIN MAGNETIC DRY ERASE BOARD

Durable, ultra-smooth board with DuraMax® porcelain surface will not scratch, dent, stain or ghost. Magnetic surface. Includes mounting hardware and four dry-erase markers.

ID No.	W x H	Frame Color	Shpg. Wt.	Unit	Price
<b>Black Aluminum Frame</b>					
10 QRT-2543B *	36" x 24"	Black	7 lbs.	Each	231.75
11 QRT-2544B *	48" x 36"	Black	13 lbs.	Each	428.45
12 QRT-2545B *	60" x 36"	Black	24 lbs.	Each	573.45
13 QRT-2547B *	72" x 48"	Black	37 lbs.	Each	792.09
14 QRT-2548B *	96" x 48"	Black	47 lbs.	Each	1,059.07
<b>Silver Aluminum Frame</b> —Includes marker rail with protective end caps.					
15 QRT-2543 *	36" x 24"	Silver	15 lbs.	Each	231.75
16 QRT-2544 *	48" x 36"	Silver	28 lbs.	Each	428.45
17 QRT-2545 *	60" x 36"	Silver	33 lbs.	Each	573.45
18 QRT-2547 *	72" x 48"	Silver	51 lbs.	Each	792.09
19 QRT-2548 *	96" x 48"	Silver	69 lbs.	Each	1,059.07

\* Cradle to Cradle Certified™ Silver.



## C MOBILE PARTITION BOARD

Write on movable partition. Create your own meeting space in any open area and have the convenience of a double-sided magnetic surfaced dry-erase board. Includes stand, markers and eraser.

ID No.	W x H	Frame Color	Shpg. Wt.	Unit	Price
20 PLS-912MPBLG	38 3/4" x 70 1/4"	Light Gray	33 lbs.	Each	564.00

## D EMAIL-CAPABLE COPYBOARD

Designed for offices or environments where ease of saving written information is a top priority while at the same time knowing it is secure. Ideal for small to large organizations, each board can store up to 5000 employee email addresses and is also capable of using those addresses to store to secure FTP server. Includes board, markers, eraser and wall mount brackets.

ID No.	W x H	Frame Color	Shpg. Wt.	Unit	Price
21 PLS-N324 *	58.3" x 39.4"	Light Gray	89 lbs.	Each	2,590.00

\* ISO 9001.

## E ELECTRONIC COPYBOARD

Thinner, lighter and loaded with advanced features including faster scanning time, quieter operation, lower energy consumption and magnet-attachable surface. Simple push-button operation makes it easy to save notes exactly as they have been written using a USB memory stick (sold separately) or directly to your PC or Mac for editing, emailing or inserting into other documents. Notes can also be printed out in either black and white or color (printer sold separately). Includes four markers (black, blue, green and red), one eraser, AC power adapter, power cord, USB cable and mounting kit.

ID No.	W x H	Frame Color	Shpg. Wt.	Unit	Price
<b>M-18W</b> —Two oversized writing surfaces.					
22 PLS-M-18W	78" x 40"	Light Gray	80 lbs.	Each	1,995.00



## F DELUXE PORCELAIN MAGNETIC DRY ERASE BOARD

Magnetic porcelain surface resists staining, scratching and ghosting. Designed for heavy-use environments, it wipes clean every time! Porcelain surface where quality matters most for smooth writing surface and a consistent white clean each time. Magnetic surface to hold papers and bulletins easily. Includes accessory tray/rail and mounting kit.

ID No.	W x H	Frame Color	Shpg. Wt.	Unit	Price
23 UNV-43841 *	36" x 24"	Silver/Black	11 lbs.	Each	240.12
24 UNV-43842 *	48" x 36"	Silver/Black	20 lbs.	Each	389.29
25 UNV-43843 *	72" x 48"	Silver/Black	38 lbs.	Each	610.95

\* ISO 9001-2008.



## universal.

### A FRAMELESS MAGNETIC GLASS MARKER BOARD

Infinity edge gives a modern look to any office or conference room. Tempered-glass dry-erase marker board will not stain, ghost, scratch or dent. Glass board surface clearly displays any color of dry-erase ink. Includes one dry-erase marker and two magnets. Mounts horizontally. Tray and hardware included.

ID No.	W × H	Shpg. Wt.	Unit	Price
1 UNV-43202	36" × 24"	22 lbs.	Each	<del>148.02</del>
2 UNV-43203	48" × 36"	39 lbs.	Each	<del>307.37</del>
3 UNV-43204	72" × 48"	71 lbs.	Each	<del>569.23</del>



U BRANDS

### B MAGNETIC GLASS DRY ERASE BOARD VALUE PACK

A perfect and functional solution for the frequent and heavy usage areas of your office, school classroom, home or any commercial space. Clean, contemporary and frameless product design lines will add a touch of subtle style to your wall. Modern frameless feature enables you to hang multiple glass boards adjacent to each other and expand the writing surface to fit your custom space needs. Premium magnetic ultimate glass writing surface will never stain or ghost. All ink erases easily with a simple eraser and the glass surface continuously outperforms all traditional melamine or painted steel dry erase writing surfaces. Occasionally, use any dry erase board spray or wet dry erase board wipes after continuous use to clean the writing surface. (6) Assorted Liquid Glass Marker; (1) High Energy Rare Earth Magnet; (1) Shag Eraser; Mounting Hardware; Instructions. Manufacturer's limited lifetime warranty.

ID No.	W × H	Color	Shpg. Wt.	Qty.	Unit	Price
4 UBR-3970U0001	36" × 24"	White	17 lbs.	1	Each	<del>119.96</del>
5 UBR-3971U0001	36" × 36"	White	25 lbs.	1	Each	<del>184.19</del>
6 UBR-3972U0001	48" × 36"	White	33 lbs.	1	Each	<del>228.36</del>
7 UBR-3973U0001	72" × 36"	White	49 lbs.	1	Each	<del>394.66</del>
8 UBR-3974U0001	72" × 48"	White	66 lbs.	1	Each	<del>499.35</del>

## quartet.

### C INVISAMOUNT™ MAGNETIC GLASS MARKER BOARD

Premium glass boards are the perfect solution for an upscale work area. Delivers classic whiteboard functionality with the enhanced, aesthetic appeal of an invisible mounting system. The board appears to float on the wall to provide an unobstructed sheet of glass for all your creative needs. Tempered, magnetic premium glass surface shows true white color and will not stain or ghost. Includes accessory tray, one marker and two high-power glass board magnets. Manufacturer's 20-year warranty.

ID No.	W × H	Color	Shpg. Wt.	Qty.	Unit	Price
9 QRT-G3922IMW	39" × 22"	White	20 lbs.	1	Each	<del>161.19</del>
10 QRT-G5028IMW	50" × 28"	White	41 lbs.	1	Each	<del>328.76</del>
11 QRT-G7442IMW	74" × 42"	White	65 lbs.	1	Each	<del>683.09</del>
12 QRT-G8548IMW	85" × 48"	White	94 lbs.	1	Each	<del>869.80</del>

### D INFINITY™ GLASS MARKER BOARD

Whiteboard features a highly durable tempered-glass surface. Designed for frequent use, it resists ghosting and staining. Write on glass with dry-erase markers. Frameless, glass design matches any office interior. Includes one Quartet dry-erase marker and two rare-earth, high power magnets. Manufacturer's 15-year warranty.

ID No.	W × H	Color	Shpg. Wt.	Qty.	Unit	Price
<b>Black Glass Magnetic Board Surface</b> —Works best with Quartet® Neon Dry Erase Markers (sold separately).						
13 QRT-G3624B	36" × 24"	Black	20 lbs.	1	Each	<del>139.96</del>
14 QRT-G7248B	72" × 48"	Black	65 lbs.	1	Each	<del>592.37</del>
<b>Frosted Glass Board Surface - Not Magnetic</b> —Clearly displays any color dry erase ink.						
15 QRT-G2418F	24" × 18"	Frost	5 lbs.	1	Each	<del>95.11</del>
16 QRT-G3624F	36" × 24"	Frost	14 lbs.	1	Each	<del>130.18</del>
17 QRT-G4836F	48" × 36"	Frost	27 lbs.	1	Each	<del>265.40</del>
18 QRT-G7248F	72" × 48"	Frost	54 lbs.	1	Each	<del>550.92</del>
19 QRT-G9648F	96" × 48"	Frost	72 lbs.	1	Each	<del>701.14</del>
<b>White Glass Magnetic Board Surface</b> —Clearly displays any color dry erase ink.						
20 QRT-G2418W	24" × 18"	White	5 lbs.	1	Each	<del>102.28</del>
21 QRT-G3624W	36" × 24"	White	18 lbs.	1	Each	<del>139.96</del>
22 QRT-G4836W	48" × 36"	White	36 lbs.	1	Each	<del>285.38</del>
23 QRT-G7248W	72" × 48"	White	72 lbs.	1	Each	<del>592.37</del>
24 QRT-G9648W	96" × 48"	White	96 lbs.	1	Each	<del>753.94</del>

# Office Furnishings Boards/Glass

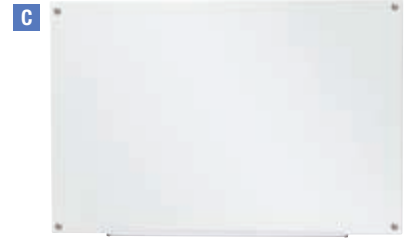

U BRANDS

## A FLOATING GLASS DRY ERASE BOARD

Perfect and functional solution for the frequent and heavy usage areas of your office, school classroom, home or any commercial space. Clean, contemporary and frameless product design. The modern frameless feature enables you to hang multiple glass boards adjacent to each other and expand the writing surface to fit your custom space needs. Premium ultimate glass writing surface will never stain or ghost. Includes: (6) Assorted Liquid Glass Marker; (1) Shag Eraser; Mounting Hardware; Instructions. Manufacturer's limited lifetime warranty.

ID No.	W x H	Color	Shpg. Wt.	Qty.	Unit	Price
1 UBR-3975U0001	36" x 24"	White	16 lbs.	1	Each	149.35
2 UBR-3976U0001	36" x 36"	White	23 lbs.	1	Each	219.00
3 UBR-3977U0001	48" x 36"	White	30 lbs.	1	Each	294.90
4 UBR-3978U0001	72" x 36"	White	45 lbs.	1	Each	415.90
5 UBR-3979U0001	72" x 48"	White	57 lbs.	1	Each	621.75

## D CUBICLE GLASS DRY ERASE BOARD

Perfect and functional solution for your work cubicle. Use the included adjustable cubicle hooks to cleanly hang the glass board over your cubicle wall. Clean, contemporary and frameless product design lines will add a touch of subtle style to your work-space. Premium ultimate glass writing surface will never stain or ghost. All ink erases easily with a simple eraser and the glass surface continuously outperforms all traditional melamine or painted steel dry erase writing surfaces. Occasionally, use any dry erase board spray or wet dry erase board wipes after continuous use to clean the writing surface. Although all dry erase markers work well with this board, the U Brands dry erase markers provide the ultimate writing and eras-ability experience. Mounting Hardware; Instructions. Manufacturer's limited lifetime warranty.

ID No.	W x H	Color	Shpg. Wt.	Qty.	Unit	Price
12 UBR-3690U0001	12" x 12"	White	11 lbs.	1	Each	32.25
13 UBR-3689U0001	20" x 16"	White	12 lbs.	1	Each	45.00



## B CLARITY GLASS DRY ERASE BOARDS

Frameless, seamless, hi-tech design with architectural quality. Combining form and function, this premium glass dry erase board features design and performance. Markers glide across the glass surface while the ultra-white backing makes writing bold and highly visible. Aluminum mounting elements allow the frameless design to "float" off the wall. 1/4" tempered safety glass will never stain or ghost. Includes clip-on marker and adjustable eraser tray. Includes marker/eraser rail and mounting kit. Manufacturer's 15-year limited warranty.

ID No.	W x H	Color	Shpg. Wt.	Qty.	Unit	Price
6 ICE-31140	48" x 36"	White	53 lbs.	1	Each	314.95
7 ICE-31150	60" x 36"	White	64 lbs.	1	Each	366.95
8 ICE-31160	72" x 36"	White	76 lbs.	1	Each	440.95



## C FRAMELESS GLASS MARKER BOARD

Glass board surface clearly displays any color of dry-erase ink. Infinity edge gives a modern look to any office or conference room. Includes one dry-erase marker. Includes marker holder and mounting kit.

ID No.	W x H	Shpg. Wt.	Unit	Price
9 UNV-43232	36" x 24"	16 lbs.	Each	125.10
10 UNV-43233	48" x 36"	30 lbs.	Each	261.84
11 UNV-43234	72" x 48"	57 lbs.	Each	512.20



## E DESKTOP MAGNETIC GLASS DRY-ERASE PANEL

Self-standing dry-erase surface keeps notes and ideas at your fingertips. Tempered glass surface is stain- and ghost-resistant for superior erasability. Double-sided surface can be used as a desk partition. Magnetic surface doubles as personal bulletin board with high-power glass board magnets. Accessory channel provides storage for markers and pens. No tools required. Includes one dry-erase marker and two high-power glass board magnets.

ID No.	W x H	Shpg. Wt.	Unit	Price
14 QRT-GDP1723W	23" x 17"	21 lbs.	Each	165.34

## F GLASS DRY ERASE DESKTOP COMPUTER PAD

Durable glass surface will not stain or ghost, ensuring a clean erase after every use. Glass dry-erase notepad is infinitely reusable and replaces the need for scrap paper. 18 x 6 size allows notepad to fit neatly in between monitor and keyboard, maximizing available desktop space. Accessory tray for markers and storage drawer keep desk clean. Includes one Quartet® dry-erase marker with an eraser cap. Manufacturer's 15-year warranty.

ID No.	W x H	Color	Shpg. Wt.	Qty.	Unit	Price
15 QRT-GDP186	18" x 6"	White	3 lbs.	1	Each	41.83



**A**



**B**



**C**

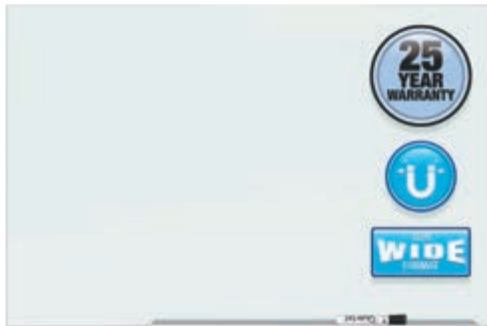

**D**



### **A** POLARITY PORCELAIN DRY ERASE BOARD

Modern hi-tech, simplicity by design. Durable porcelain magnetic writing surface will never stain, easy to clean and lasts forever. Writes smooth and bold—ideal for heavy use in high profile collaborative space. Blends seamlessly to today's technology. Clean lines, minimal aluminum frame for conference room, training/meeting areas and open plan environments. Floating marker rail and adjustable eraser tray. 15-year manufacturer's limited warranty.

ID No.	W × H	Frame Color	Shpg. Wt.	Unit	Price
1 ICE-31460	72" × 44"	Silver	35 lbs.	Each	559.95
2 ICE-31480	96" × 44"	Silver	66 lbs.	Each	649.95



### **C** ELEMENT™ FRAMED MAGNETIC GLASS DRY-ERASE BOARDS

Premium glass dry-erase surface and modern aluminum frame combine beautifully for superior performance that will fit any professional environment.

ID No.	W × H	Frame Color	Shpg. Wt.	Unit	Price
5 QRT-G5028E	50" × 28"	Silver	42 lbs.	Each	371.23
6 QRT-G7442E	74" × 42"	Silver	75 lbs.	Each	769.03
7 QRT-G8548E	85" × 48"	Silver	116 lbs.	Each	981.18

## MasterVision®

### **B** CONFERENCE CABINET

The 3-in-1 conference cabinet is a perfect all-in-one solution for office or conference room spaces. The bulletin board features a magnetic porcelain surface that resists scratching and ghosting and is suitable for extensive use. The large door features a easy no-pinch fully adjustable easel pad retainer. The retractable matte projection screen is perfect for presenting your PowerPoint presentations or slides. The cabinet's laminate surface cleans easily and withstands years of use. The contemporary matte handles make this a striking addition to any decor. Includes retractable projection screen, conference cabinet and heavy-duty easer-mount hardware.

ID No.	W × H	Frame Color	Shpg. Wt.	Unit	Price
3 BVC-CAB01010130	48" × 48"	Cherry	108 lbs.	Each	1,498.92
4 BVC-CAB01010143	48" × 48"	Ebony	108 lbs.	Each	1,498.92

## MasterVision®

### **D** MAGNETIC GLASS DRY ERASE BOARD

Durable magnetic glass board presents a fine dry erase surface for everyday use. Glass surface never stains or ghosts. It is easy to clean and is perfect for extensive use. There is no visible mounting hardware—it's all on the back of the board, providing seamless and clean aesthetics.

ID No.	W × H	Color	Shpg. Wt.	Qty.	Unit	Price
8 BVC-GL070101	36" × 24"	Opaque White	18 lbs.	1	Each	416.49
9 BVC-GL080101	48" × 36"	Opaque White	33 lbs.	1	Each	678.29
10 BVC-GL110101	60" × 48"	Opaque White	56 lbs.	1	Each	1,079.99

\* ISO 9001-2008.

Prices subject to change without notice.  
Visit our website for the latest pricing and product information.

# Office Furnishings Boards/Dry Erase, Magnetic

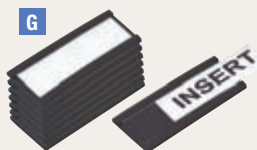
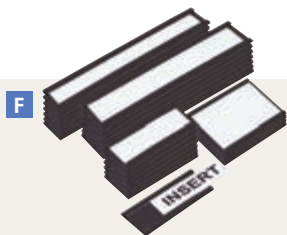

## MasterVision®

### A GOLD ULTRA™ MAGNETIC DRY ERASE BOARDS

Magnetic Gold Ultra™ dry erase, lacquered steel surface is suitable for frequent use. Sleek, contemporary frame. Full-length aluminum tray. Includes accessory tray/rail and mounting kit.

ID No.	W × H	Frame Color	Shpg. Wt.	Unit	Price
1 BVC-MV1030201 ★	36" × 24"	Aluminum/Black	13 lbs.	Each	<del>194.76</del>
2 BVC-MV1030205	36" × 24"	Aluminum/White	13 lbs.	Each	<del>194.76</del>
3 BVC-MV1050201	48" × 36"	Aluminum/Black	22 lbs.	Each	<del>364.40</del>
4 BVC-MV1050205	48" × 36"	Aluminum/White	22 lbs.	Each	<del>364.40</del>
5 BVC-MV1270201	72" × 48"	Aluminum/Black	44 lbs.	Each	<del>687.24</del>
6 BVC-MV1270205	72" × 48"	Aluminum/White	44 lbs.	Each	<del>687.24</del>

★ BVC-MV1030201—ISO 9001-2008.

### B EARTH GOLD ULTRA™ MAGNETIC DRY ERASE BOARDS

Providing the best quality from recycled and recyclable materials, Magnetic Gold Ultra™ dry erase board provides professional performance. Lacquered steel surface is suitable for frequent use. Sturdy aluminum frame features the four-corner system for easy mounting. Includes accessory tray/rail and mounting kit.

ID No.	W × H	Frame Color	Shpg. Wt.	Unit	Price
7 BVC-MA0307790 ★	24" × 36"	Silver	9 lbs.	Each	<del>276.35</del>
8 BVC-MA2707790 ★	48" × 72"	Silver	32 lbs.	Each	<del>618.58</del>
9 BVC-MA2107790 ★	96" × 48"	Silver	59 lbs.	Each	<del>801.62</del>

★ ISO 9001-2008, Board contains a minimum of 45% pre-consumer recycled content and a minimum of 45% post-consumer content. Reinforced aluminum frame contains 100% post-consumer recycled content.

### C VALUE LACQUERED STEEL MAGNETIC DRY ERASE BOARD

Magnetic lacquered steel Gold Ultra™ surface resists staining, suitable for frequent use. The frame is sturdy aluminum with an easy-to-mount four-corner system that can be mounted vertically or horizontally. Includes full length aluminum tray, four corner mounting kit, instructions.

ID No.	W × H	Frame Color	Shpg. Wt.	Unit	Price
10 BVC-MA0207170 ★	18" × 24"	Silver	5 lbs.	Each	<del>44.65</del>
11 BVC-MA0307170 ★	24" × 36"	Silver	9 lbs.	Each	<del>103.07</del>
12 BVC-MA0507170 ★	48" × 36"	Silver	17 lbs.	Each	<del>206.19</del>
13 BVC-MA2707170 ★	72" × 48"	Silver	32 lbs.	Each	<del>378.15</del>
14 BVC-MA2107170 ★	96" × 48"	Silver	60 lbs.	Each	<del>423.93</del>

★ ISO 9001-2008.



### D DRY ERASE ACCESSORY TRAY

Ideal companion for the Post-it® Super Sticky Dry Erase Surfaces or any surface which requires writing tools available on a vertical surface. The tray comes with four Command™ Mounting Strips which will hold strongly, up to four pounds, yet remove cleanly. Damage-free hanging for all your dry erase essentials. 8½" × 3" × 5¼".

ID No.	For Model Number	Material	Unit	Price
15 MMM-DEFTRAY	DEF3X2; DEF4X3; DEF6X4; DEF8X4	Plastic	Each	<del>11.25</del>

### E DRY ERASE CLEANING CLOTH

Great for everyday erasing of dry erase markers. The cloth lifts and traps marker dust and cleans dry erase surfaces without the use of sprays or chemicals. It can be machine-washed and will continue to perform on dry erase surfaces without the need to use chemicals.

ID No.	Width	Unit	Price
16 MMM-DEFCLOTH	10%"	Each	<del>5.42</del>

## MasterVision®

### F MAGNETIC DATA CARDS

Magnetic accessories make building and maintaining your planning board easier. Arrange data easily and quickly when changes become necessary. These magnetic blank data cards feature slots above and below to hold cardstock labels and can be used on any steel surface.

ID No.	Width × Height	Color	Qty.	Unit	Price
17 BVC-FM1310 ★	2" × 1"	Black	25	Pack	<del>11.43</del>
18 BVC-FM1325 ★	2" × 1"	White	25	Pack	<del>25.99</del>
19 BVC-FM2630 ★	3" × 1¾"	Black	10	Pack	<del>11.43</del>
20 BVC-FM2631 ★	6" × ½"	Black	10	Pack	<del>9.35</del>
21 BVC-FM2632 ★	6" × 1"	Black	10	Pack	<del>9.35</del>
22 BVC-FM2633 ★	6" × 2"	Black	10	Pack	<del>20.79</del>

★ Trade Act Compliant; ISO:9001-2008.

### G DATA CARD PAPER INSERTS

Maximize your productivity and organize your work with efficiency. Magnetic data card paper refills make changing the info on your data cards easy and fast.

ID No.	Width × Height	Color	Qty.	Unit	Price
23 BVC-FM1312 ★	2" × 1"	Assorted	1000	Pack	<del>13.51</del>
24 BVC-FM1513 ★	3" × 1¾"	White	500	Pack	<del>25.99</del>
<b>1" H Perforated Sheets</b> —Horizontal perforations every 1". Cut to desired width.					
25 BVC-FM1615 ★	Cut-to-Fit W × 1"	White	10	Pack	<del>5.19</del>
26 BVC-FM1614 ★	Cut-to-Fit W × 1"	Assorted	10	Pack	<del>5.19</del>

★ ISO 9001-2000.

BVC-FM1312, BVC-FM1614—Blue; Lime; Salmon; White; Yellow.



## A FUSION NANO-CLEAN™ MAGNETIC WHITEBOARD

Incorporating the latest cutting-edge science, this innovative new whiteboard uses nanotechnology to prevent ink from penetrating the surface. Hydrophobic Nano-Clean™ coating delivers superior erasability and exceptional ghost and stain resistance. Easily mounts with a horizontal or vertical orientation using the included Z-bracket hardware. Includes marker tray and one Quartet® dry-erase marker.

ID No.	W × H	Frame Color	Shpg. Wt.	Unit	Price
1 QRT-NA3624FB	36" × 24"	Black	5 lbs.	Each	176.33
2 QRT-NA3624F	36" × 24"	Silver	5 lbs.	Each	176.33
3 QRT-NA4836FB	48" × 36"	Black	15 lbs.	Each	330.66
4 QRT-NA4836F	48" × 36"	Silver	15 lbs.	Each	330.66
5 QRT-NA7248FB	72" × 48"	Black	30 lbs.	Each	596.35
6 QRT-NA7248F	72" × 48"	Silver	30 lbs.	Each	596.35
7 QRT-NA9648FB	96" × 48"	Black	37 lbs.	Each	799.18
8 QRT-NA9648F	96" × 48"	Silver	37 lbs.	Each	799.18



## B MAGNETIC STEEL DRY ERASE MARKER BOARD

Dry-erase board doubles as magnetic bulletin board. Magnetic lacquered-steel surface is suitable for frequent use and is compatible with all dry-erase markers. Four-corner system enables vertical and horizontal mounting. Includes accessory tray/rail and mounting kit.

ID No.	W × H	Frame Color	Shpg. Wt.	Unit	Price
9 UNV-43732	24" × 18"	Aluminum	5 lbs.	Each	115.02
10 UNV-43733	36" × 24"	Aluminum	9 lbs.	Each	205.73
11 UNV-43734	48" × 36"	Aluminum	18 lbs.	Each	320.70
12 UNV-43735	72" × 48"	Aluminum	35 lbs.	Each	602.12



## C CLASSIC SERIES NANO-CLEAN™ DRY ERASE BOARD

Board has a durable, hydrophobic surface coating that prevents ink from penetrating the surface. Magnetic surface for posting documents. Frame is sturdy and stylish. Includes mounting hardware, marker tray and one Quartet® dry-erase marker. Includes one Quartet® dry-erase marker and mounting kit.

ID No.	W × H	Frame Color	Shpg. Wt.	Unit	Price
<b>Black Aluminum Frame</b>					
13 QRT-SM531B	24" × 18"	Black	6 lbs.	Each	64.57
14 QRT-SM533B	36" × 24"	Black	7 lbs.	Each	125.95
15 QRT-SM534B	48" × 36"	Black	7 lbs.	Each	236.91
16 QRT-SM535B	60" × 36"	Black	25 lbs.	Each	294.00
17 QRT-SM537B	72" × 48"	Black	39 lbs.	Each	414.65
18 QRT-SM538B	96" × 48"	Black	49 lbs.	Each	534.20
<b>Silver Aluminum Frame</b>					
19 QRT-SM531	24" × 18"	Silver	6 lbs.	Each	64.57
20 QRT-SM533	36" × 24"	Silver	7 lbs.	Each	125.95
21 QRT-SM534	48" × 36"	Silver	7 lbs.	Each	236.91
22 QRT-SM535	60" × 36"	Silver	25 lbs.	Each	294.00
23 QRT-SM537	72" × 48"	Silver	39 lbs.	Each	414.65
24 QRT-SM538	96" × 48"	Silver	49 lbs.	Each	534.20

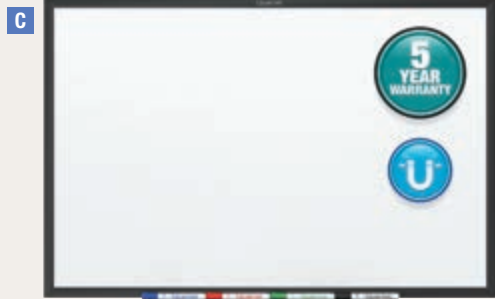

## MasterVision®

### D DRY ERASE MAGNETIC TAPE

Magnetic accessories make building and maintaining your planning board easier. Arrange data easily and quickly when changes become necessary. Cut pieces to the size you need. Each strip can be written on with dry erase markers and is great for all magnetic surfaces: boards, file cabinets, storage lockers and more.

ID No.	Size	Color	Qty.	Unit	Price
<b>Pre-cut Labels</b>					
25 BVC-FM2418	7/8" × 2"	White	25	Pack	10.39
26 BVC-FM2518	7/8" × 6"	White	25	Pack	25.99
<b>Magnetic Tape Roll—Cut to desired length.</b>					
27 BVC-FM2018	1" × 50 ft	White	1	Each	83.20
28 BVC-FM2118	2" × 50 ft	White	1	Each	135.20
29 BVC-FM2218	3" × 50 ft	White	1	Each	187.20

### E MAGNETIC ADHESIVE TAPE ROLL

Magnetic accessories make building and maintaining your planning board easier. Arrange data easily and quickly when changes become necessary. Print paper labels and apply to the adhesive side. Attach pictures, business cards and more. Great for all magnetic surfaces: boards, file cabinets, storage lockers and more.

ID No.	Size	Color	Qty.	Unit	Price
30 BVC-FM2319	1/2" × 7 ft	Black	1	Each	7.27
31 BVC-FM2020	1" × 4 ft	Black	1	Each	10.40
<b>Value Pack—Stock up and save!</b>					
32 BVC-FM2321	1/2" × 50 ft	Black	1	Each	41.59
33 BVC-FM2021	1" × 50 ft	Black	1	Each	52.00

Prices subject to change without notice.  
Visit our website for the latest pricing and product information.

# Office Furnishings Boards/Dry Erase, Magnetic



## universal.

### A DESIGN SERIES DELUXE MAGNETIC STEEL DRY ERASE MARKER BOARD

Sleek black, heavy-duty frame sets the Design Series apart, lending it a contemporary style that's perfect for personal and communal settings. Lacquered steel surface doubles as both a dry-erase board and a magnetic bulletin board, and it also makes this board ideal for frequent-use environments. Compatible with all dry-erase markers. Includes accessory tray/rail and mounting kit.

ID No.	W × H	Frame Color	Shpg. Wt.	Unit	Price
1 UNV-43024	24" × 18"	Black	5 lbs.	Each	120.66
2 UNV-43025	36" × 24"	Black	9 lbs.	Each	191.57
3 UNV-43026	48" × 36"	Black	16 lbs.	Each	325.47

## quartet.

### B CONTOUR® DRY ERASE BOARD

Durable whiteboard with smooth surface. Delivers effective performance in low-use personal environments. Flexible mounting system secures board to wall in two orientations to accommodate any space. Textured plastic frame. Includes one dry-erase marker and mounting kit.

ID No.	W × H	Frame Color	Shpg. Wt.	Unit	Price
4 QRT-7551	24" × 18"	Black	4 lbs.	Each	57.09
5 QRT-7553	36" × 24"	Black	7 lbs.	Each	88.99
6 QRT-7554	48" × 36"	Black	14 lbs.	Each	125.55

### C IQ™ TOTAL ERASE® TRANSLUCENT-EDGE BOARD

Sleek board with highly durable Total Erase® surface resists staining, ghosting, scratching and denting. Delivers quality performance in frequent-use collaborative environments. Translucent frame for edge-to-edge writing surface. Flexible mounting. Includes one Quartet® dry-erase marker and mounting kit. [✎](#)

ID No.	W × H	Frame Color	Shpg. Wt.	Unit	Price
7 QRT-TM1107 ★	11" × 7"	Clear	1 lb.	Each	29.64
8 QRT-TM2316	23" × 16"	Clear	7 lbs.	Each	87.85
9 QRT-TM3623	36" × 23"	Clear	13 lbs.	Each	143.80
10 QRT-TM4929	49" × 32"	Clear	23 lbs.	Each	246.57

★ QRT-TM1107—Installs with magnets, fabric grip or double stick tape.

## MasterVision®

### D INTERCHANGEABLE MAGNETIC CHARACTERS

Maximize your productivity and organize work with efficiency. Versatile solution that can be used with MasterVision® magnetic dry erase boards or any magnetic surface. Remove with ease for quick changes. Includes 9 each: E; 7 each: A, O; 6 each: I, N, R, S, T; 5 each: L; 4 each: C, D, H, M, P, U; 3 each: B, F, G, J, W, Y, Comma (,), Period (.); 2 each: K, Q, V, X, Z, Dash(-); 1 each: Ampersand (&), Arrow.

**⚠ WARNING: CHOKING HAZARD—Small parts. Not for children under 3 yrs.**

ID No.	Height	Color	Qty.	Unit	Price
<b>Letters</b> —Set of 120 uppercase letters and punctuation marks.					
11 BVC-KT2221	¾"	Red, White	1	Each	23.91
12 BVC-KT2220	¾"	Black, White	1	Each	23.91
<b>Numbers</b> —Set of 10 each 1-10 and \$, €, % and decimal points.					
13 BVC-KT2020	¾"	Black	1	Each	23.91
<b>Calendar Dates 1-31</b> —Magnetic tape.					
14 BVC-FM1209	1"	Red; White	35	Pack	9.35
<b>Days of the Week</b> —Magnetic tape.					
15 BVC-FM1007	1"	Black; White	7	Pack	6.23
<b>Months of the Year</b> —Magnetic tape.					
16 BVC-FM1108	1"	Black; White	12	Pack	8.31





## universal.

### A MODERN MELAMINE DRY ERASE BOARD WITH ALUMINUM FRAME

Stylish, durable, high-quality, wall-mountable board is an indispensable office addition that's perfect for occasional use. Melamine surface accepts all dry-erase markers. Contoured aluminum frame features attractive, protective black-plastic corners. Extra-wide marker/eraser tray. May be mounted vertically or horizontally. Includes accessory tray and easy four-corner mounting kit.

ID No.	W x H	Frame Color	Shpg. Wt.	Unit	Price
1 UNV-43722	24" x 18"	Aluminum	4 lbs.	Each	50.28
2 UNV-43723	36" x 24"	Aluminum	7 lbs.	Each	80.16
3 UNV-43724	48" x 36"	Aluminum	12 lbs.	Each	117.36
4 UNV-43725	72" x 48"	Aluminum	34 lbs.	Each	323.58

### B MELAMINE DRY ERASE BOARD WITH ALUMINUM FRAME

Aluminum framed melamine board adds strength and durability. Simple classic slim-line frame design. Melamine surface is great for meetings and presentations. Full length integrated marker tray. Mounts easily with included hardware. Mounts horizontally. Includes mounting kit.

ID No.	W x H	Frame Color	Shpg. Wt.	Unit	Price
<b>Marker Rail</b>					
5 UNV-43622	24" x 18"	Aluminum	4 lbs.	Each	37.14
6 UNV-43623	36" x 24"	Aluminum	7 lbs.	Each	65.47
7 UNV-43624	48" x 36"	Aluminum	12 lbs.	Each	116.78

## quartet.

### D CLASSIC SERIES TOTAL ERASE® DRY ERASE BOARDS

Enhanced Total Erase® surface resists staining and ghosting to create a clean surface every time with only occasional maintenance. This dry-erase board is best suited for moderate use in spaces with regular traffic. Features a stylish frame and matching marker tray. Includes one Quartet® marker. Includes one Quartet® dry-erase marker and mounting hardware.

ID No.	W x H	Frame Color	Shpg. Wt.	Unit	Price
<b>Black Aluminum Frame</b>					
10 QRT-S531B	24" x 18"	Black	5 lbs.	Each	43.00
11 QRT-S533B	36" x 24"	Black	7 lbs.	Each	68.06
12 QRT-S534B	48" x 36"	Black	17 lbs.	Each	112.00
13 QRT-S535B	60" x 36"	Black	24 lbs.	Each	226.28
14 QRT-S537B	72" x 48"	Black	37 lbs.	Each	287.79
15 QRT-S538B	96" x 48"	Black	47 lbs.	Each	371.31
<b>Silver Aluminum Frame</b>					
16 QRT-S531	24" x 18"	Silver	5 lbs.	Each	43.00
17 QRT-S533	36" x 24"	Silver	8 lbs.	Each	68.06
18 QRT-S534	48" x 36"	Silver	17 lbs.	Each	112.00
19 QRT-S535	60" x 36"	Silver	24 lbs.	Each	226.28
20 QRT-S537	72" x 48"	Silver	38 lbs.	Each	287.79
21 QRT-S538	96" x 48"	Silver	49 lbs.	Each	371.31

## quartet.

### C MELAMINE WHITEBOARD

Durable whiteboard with smooth writing surface. Delivers effective performance in low-use active learning environments. Includes accessory tray/rail and installation kit.

ID No.	W x H	Frame Color	Shpg. Wt.	Unit	Price
8 QRT-EMA406	72" x 48"	Silver Aluminum	40 lbs.	Each	295.51
9 QRT-EMA408	96" x 48"	Silver Aluminum	53 lbs.	Each	274.02



**Fast Delivery**  
In most cases, the next business day!

## MasterVision®

### E EARTH SILVER EASY-CLEAN DRY ERASE BOARD

Basic whiteboard combines durability, superior visibility, exceptionally smooth writing/erasing and scratch resistance. Sturdy aluminum frame features the four-corner system for easy wall mounting vertically or horizontally. Includes accessory tray/rail and mounting kit.

ID No.	W x H	Frame Color	Shpg. Wt.	Unit	Price
<b>Melamine—Reversible—</b> simply flip the board to extend use.					
22 BVC-MA0200790	24" x 18"	Silver	5 lbs.	Each	57.23
23 BVC-MA0300790	36" x 24"	Silver	8 lbs.	Each	114.49
24 BVC-MA0500790	48" x 36"	Silver	21 lbs.	Each	194.87
25 BVC-MA2700790	72" x 48"	Silver	39 lbs.	Each	401.06
26 BVC-MA2100790	96" x 48"	Silver	50 lbs.	Each	608.04

★ ISO 9001-2008.

BVC-MA0200790, BVC-MA0300790, BVC-MA0500790, BVC-MA2700790—Contains 20% post-consumer recycled material, 100% total recycled material.

BVC-MA2100790—C2C Bronze Certified.

# Office Furnishings Boards/Dry Erase

universal.

**A DESIGN SERIES DELUXE DRY ERASE BOARD** Perfect for personal work areas and occasional use. Sleek black, heavy-duty frame. Four-corner system enables vertical and horizontal mounting. Includes mounting kit.

ID No.	W × H	Frame Color	Shpg. Wt.	Unit	Price
1 UNV-43630	24" × 18"	Black	4 lbs.	Each	53.48
2 UNV-43628	36" × 24"	Black	6 lbs.	Each	83.46
3 UNV-43629	48" × 36"	Black	11 lbs.	Each	117.82

**B DELUXE MELAMINE DRY ERASE BOARD** Deluxe, ultra-durable board is built to last. Whether you choose to go contemporary with an aluminum frame or traditional with a wood frame, its classic, low-impact design will blend right in. Easy-to-erase, high-quality melamine surface. May be mounted horizontally or vertically. Marker/eraser tray. Includes mounting kit.

ID No.	W × H	Frame Color	Shpg. Wt.	Unit	Price
<b>Aluminum Frame</b>					
4 UNV-44618	24" × 18"	Silver	5 lbs.	Each	41.38
5 UNV-44624	36" × 24"	Silver	7 lbs.	Each	67.99
6 UNV-44636	48" × 36"	Silver	13 lbs.	Each	112.27
7 UNV-43625	60" × 36"	Silver	17 lbs.	Each	229.96
8 UNV-43626	72" × 48"	Silver	34 lbs.	Each	328.02
9 UNV-43627	96" × 48"	Silver	46 lbs.	Each	426.71
<b>Wood Frame</b>					
10 UNV-43619	36" × 24"	Oak	8 lbs.	Each	75.61
11 UNV-43618	48" × 36"	Oak	15 lbs.	Each	127.44
12 UNV-43621	72" × 48"	Oak	37 lbs.	Each	391.93
13 UNV-43620	96" × 48"	Oak	48 lbs.	Each	517.68

## MasterVision®

**C VALUE MELAMINE DRY ERASE BOARD** Melamine surface dry erase board is designed for occasional use and excellent value. Sturdy anodized aluminum frame includes a snap-on pen tray. Vertical or horizontal mounting is easy with the four-corner system. Includes snap on pen tray, four corner mounting kit, instructions

ID No.	W × H	Frame Color	Shpg. Wt.	Unit	Price
14 BVC-MA0312170MV *	24" × 36"	Silver	11 lbs.	Each	65.54
15 BVC-MA0512170MV *	36" × 48"	Silver	20 lbs.	Each	110.40
16 BVC-MA2712170MV *	48" × 72"	Silver	39 lbs.	Each	275.22
17 BVC-MA2112170MV *	48" × 96"	Silver	50 lbs.	Each	294.89

\* ISO Compliant.



U BRANDS

**D MICROFIBER SHAG DRY ERASE BOARD ERASER** This fun and soft whiteboard eraser performs on all dry erase surfaces and erases any dry erase marker ink. Great for use on all melamine, painted steel, porcelain, glass and other dry erase board surfaces. The fun contoured design fits comfortably in the palm of your hand for extremely precise erasing. Great for use in any office, classroom, meeting room, board room and more!

ID No.	Width	Size	Unit	Price
18 UBR-582U0416	2½"	Small	Each	8.00
19 UBR-2931U0006	3¾"	Large	Each	13.52

**E BULLET TIP LOW-ODOR LIQUID GLASS MARKERS WITH ERASERS** Features bold and vibrant color inks that dry quickly, erase easily and work great on any glass board surface. Also features the longest lasting, non-toxic, low odor ink that is great in any classroom, home or office environment. Bullet tip for a bold and precise writing experience. Each marker cap offers a built-in eraser.

ID No.	Color	Tip	Size	Qty.	Unit	Price
20 UBR-2913U0012 *	Assorted	Bullet	Broad	12	Pack	29.04

\* Black; Blue; Green; Orange; Pink; White.



U BRANDS

**F MEDIUM POINT LOW-ODOR DRY-ERASE MARKERS WITH ERASERS** Features bold and vibrant color inks that dry quickly, erase easily and work great on any dry erase board surface. Also features long-lasting, non-toxic, low odor ink that is great in any classroom, home, office or commercial environment. Medium tip for a precise writing experience on any melamine, painted steel, porcelain or glass dry erase surface. Built-in felt eraser into the marker cap enables quick, convenient and precise erasing.

ID No.	Color	Tip	Size	Qty.	Unit	Price
21 UBR-2922U0012	Black	Bullet	Medium	1	Dozen	13.99
22 UBR-3980U0012 *	Assorted	Bullet	Medium	12	Pack	13.99

\* UBR-3980U0012—3 Black; 3 Blue; 3 Green; 3 Red.

**G CHISEL TIP LOW-ODOR DRY-ERASE MARKERS WITH ERASERS** Features bold and vibrant color inks that dry quickly, erase easily and work great on any dry erase board surface. Also features long-lasting, non-toxic, low odor ink that is great in any classroom, home or office environment. Chisel tip for a bold and precise writing experience on any melamine, painted steel, porcelain or glass dry erase surface. The built-in felt eraser into the marker cap.

ID No.	Color	Tip	Size	Qty.	Unit	Price
23 UBR-2925U0012	Black	Chisel	Broad	1	Dozen	21.60
24 UBR-3981U0012 *	Assorted	Chisel	Broad	12	Pack	21.60

\* UBR-3981U0012—3 Black; 3 Blue; 3 Green; 3 Red.



**H PRESTIGE 2 CONNECTS™ MARKER CADDY** Convenient black caddy comes with a detachable hook so that it can be easily connected to the side of any Quartet® Prestige® 2 whiteboard. Markers and eraser included. Measures: 6½w × 3½d × 8¼h.

ID No.	Color	Tip	Size	Qty.	Unit	Price
25 QRT-85377 *	Assorted	Chisel	Broad	1	Each	34.70

\* Black; Blue; Green; Red.

**I PREMIUM GLASS BOARD DRY ERASE MARKER** Optimized for use on contemporary glass surface boards. Delivers bold color with best in class liquid ink delivery system. Low odor, easy to erase markers are great for any environment. Bullet tip creates thick, broad lines for messages that are clear and easy to read both up close and from a distance. Markers feature a see-through ink gauge to clearly see how much ink remains.

ID No.	Color	Tip	Size	Qty.	Unit	Price
26 QRT-79552 *	Assorted	Bullet	Broad	4	Pack	11.56

\* Black; Blue; Green; Red.

universal.

**J MICROFIBER CLEANING CLOTH** Microfiber cloths for all board cleaning without the need to use board cleaners. Safe for all types of surfaces. Cloths are machine-washable for re-use—no need to discard after use. Use alone to clean and dust any surface or with cleaning spray.

ID No.	W × L	Qty.	Unit	Price
27 UNV-43664	12" × 12"	3	Pack	10.99

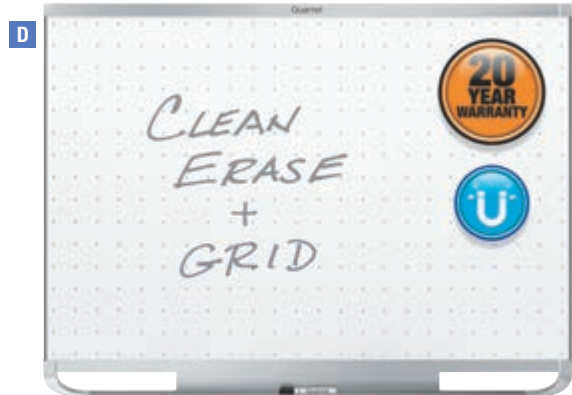

U BRANDS

### A PINIT MAGNETIC DRY ERASE BOARD

Perfect and functional solution for the frequent usage areas of your office, school classroom, home or any commercial space. Magnetic painted steel writing surface will require minimal ongoing cleaning care to ensure the best performance and resist ink staining and ghosting. Whiteboard has a universal mounting system, as it can be hung vertically or horizontally to fit your allocated space. Mounting Hardware; Instructions.

ID No.	W x H	Frame Color	Shpg. Wt.	Unit	Price
1 UBR-2804U0001	24" x 18"	Silver	5 lbs.	Each	67-95
2 UBR-2805U0001	36" x 24"	Silver	9 lbs.	Each	115-91
3 UBR-2806U0001	36" x 36"	Silver	14 lbs.	Each	162-41
4 UBR-2807U0001	48" x 36"	Silver	17 lbs.	Each	227-05
5 UBR-2808U0001	72" x 48"	Silver	34 lbs.	Each	421-93
6 UBR-2809U0001	96" x 48"	Silver	46 lbs.	Each	536-21

### B FLOATING GLASS GHOST GRID DRY ERASE BOARD

A perfect and functional solution for the frequent and heavy usage areas of your office, school classroom, home or any commercial space. Clean, contemporary and frameless product design lines will add a touch of subtle style to your wall. Modern frameless feature enables you to hang multiple glass boards adjacent to each other and expand the writing surface to fit your custom space needs. Premium ultimate glass writing surface will never stain or ghost. Mounting Hardware; Instructions. Manufacturer's limited lifetime warranty.

ID No.	W x H	Color	Shpg. Wt.	Qty.	Unit	Price
7 UBR-2798U0001	36" x 24"	White	18 lbs.	1	Each	134-04
8 UBR-2799U0001	48" x 36"	White	32 lbs.	1	Each	279-70



### C PRESTIGE® 2 TOTAL ERASE® WHITEBOARD

The stain and ghost resistant surface of a Total Erase® whiteboard consistently performs like new. Board erases clean and works with Connects™ accessories. Includes one Quartet® dry-erase marker and mounting kit.

ID No.	W x H	Frame Color	Shpg. Wt.	Unit	Price
9 QRT-TE543GP2	36" x 24"	Graphite	12 lbs.	Each	114-13
10 QRT-TE543MP2	36" x 24"	Mahogany	12 lbs.	Each	114-13
11 QRT-TE543AP2	36" x 24"	Silver	12 lbs.	Each	114-13
12 QRT-TE544GP2	48" x 36"	Graphite	19 lbs.	Each	188-34
13 QRT-TE544MP2	48" x 36"	Mahogany	19 lbs.	Each	188-34
14 QRT-TE544AP2	48" x 36"	Silver	19 lbs.	Each	188-34
15 QRT-TE547MP2	72" x 48"	Mahogany	37 lbs.	Each	482-91
16 QRT-TE547AP2	72" x 48"	Silver	37 lbs.	Each	482-91
17 QRT-TE548MP2	96" x 48"	Mahogany	46 lbs.	Each	600-50
18 QRT-TE548AP2	96" x 48"	Silver	46 lbs.	Each	600-50

### D PRESTIGE® 2 MAGNETIC TOTAL ERASE® WHITEBOARD

Magnetic Total Erase® whiteboard resists ghosting and staining. Board doubles as a magnetic bulletin board and erases cleanly. Includes accessory tray, one dry-erase marker and mounting hardware.

ID No.	W x H	Frame Color	Shpg. Wt.	Unit	Price
19 QRT-TEM543M	36" x 24"	Mahogany	12 lbs.	Each	162-25
20 QRT-TEM544G	48" x 36"	Graphite	19 lbs.	Each	302-19
21 QRT-TEM544A	48" x 36"	Silver	19 lbs.	Each	302-19
22 QRT-TEM547G	72" x 48"	Graphite	40 lbs.	Each	533-89
23 QRT-TEM547M	72" x 48"	Mahogany	40 lbs.	Each	533-89
24 QRT-TEM547A	72" x 48"	Silver	40 lbs.	Each	533-89
25 QRT-TEM548B	96" x 48"	Black	52 lbs.	Each	687-22
26 QRT-TEM548A	96" x 48"	Silver	53 lbs.	Each	687-22

Prices subject to change without notice.

Visit our website for the latest pricing and product information.

# Office Furnishings Boards/Planning

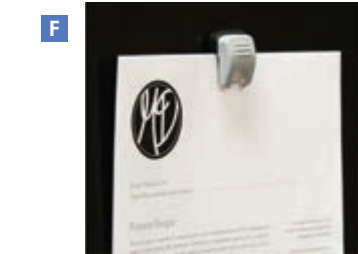
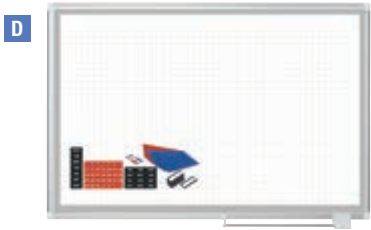

## MasterVision®

### A GRIDDED MAGNETIC PORCELAIN DRY ERASE PLANNING BOARD

Pale gray grid. The magnetic porcelain baked enamel surface resists staining, ghosting and scratching. Sturdy aluminum frame features an easy four-corner mounting system. Includes accessory tray/rail and mounting kit. Manufacturer's lifetime surface warranty. 📦

ID No.	Columns/ Rows	W × H	Frame Color	Shpg. Wt.	Unit	Price
<b>1 × 2 Grid</b>						
1	BVC-CR1230830 ★	45	72" × 48"	Silver	38 lbs. Each	749.92
<b>1 × 2 Grid</b> —Includes accessory pack with 10 data card holders, printed magnets (months, days of the week, 1-31) and colored magnet shapes.						
2	BVC-CR1230830A ★	45	72" × 48"	Silver	38 lbs. Each	780.52
★ ISO 9001-2008.						

### B GRIDDED MAGNETIC STEEL DRY ERASE PLANNING BOARD

Pale gray grid lines help ensure easy alignment of text and magnetic accessories. Magnetic lacquered steel dry erase surface is suitable for frequent use. Sturdy aluminum frame features a sliding pen tray and an easy four-corner mounting system. Includes accessory tray/rail and mounting kit. Manufacturer's 10-year surface warranty.

ID No.	Columns/ Rows	W × H	Frame Color	Shpg. Wt.	Unit	Price
<b>1" Grid</b>						
3	BVC-MA2747830 ★ 📦	47	72" × 48"	Silver	36 lbs. Each	686.98
<b>1" × 2" Grid</b>						
4	BVC-MA0392830 ★	23	36" × 24"	Silver	9 lbs. Each	194.64
5	BVC-MA0592830 ★	35	48" × 36"	Silver	18 lbs. Each	366.26
6	BVC-MA2792830 ★ 📦	47	72" × 48"	Silver	36 lbs. Each	686.98
<b>1" × 2" Grid</b> —Includes accessory pack with 10 data card holders, printed magnets (months, days of the week, 1-31) and colored magnet shapes.						
7	BVC-MA0392830A ★	23	36" × 24"	Silver	9 lbs. Each	228.97
8	BVC-MA0592830A ★ 📦	35	48" × 36"	Silver	18 lbs. Each	400.59
9	BVC-MA2792830A ★ 📦	47	72" × 48"	Silver	37 lbs. Each	721.32
<b>2" × 3" Grid</b>						
10	BVC-MA0593830 ★	17	48" × 36"	Silver	18 lbs. Each	366.26
★ ISO 9001-2008.						

### C RULED MAGNETIC STEEL DRY ERASE PLANNING BOARD

Pale gray rule lines simplify text and magnetic accessory alignment. Magnetic lacquered steel dry erase surface is recommended for frequent use. Sturdy aluminum frame features a sliding pen tray and an easy four-corner mounting system. Manufacturer's 10-year surface warranty.

ID No.	Rows	W × H	Frame Color	Shpg. Wt.	Unit	Price
11	BVC-MA0594830 ★	35	48" × 36"	Silver	18 lbs. Each	366.26
12	BVC-MA2794830 ★ 📦	47	72" × 48"	Silver	36 lbs. Each	686.98
★ ISO 9001-2008.						

### D ALL PURPOSE MAGNETIC DRY ERASE PLANNING BOARD

1" × 2" pale gray grid lines simplify planning and allow easy alignment of magnetic accessories. Extra wide row at the top and an extra wide column to the left allow room for headers and extra data. Included magnetic accessory kit. The magnetic surface resists staining, ghosting and scratching. Sturdy aluminum frame features an easy four-corner mounting system and sliding tray.

ID No.	Rows	W × H	Frame Color	Shpg. Wt.	Unit	Price
<b>Lacquered Steel Dry Erase Surface with 1" × 2" Grid</b> —Includes accessory pack with 25 card holders (months, weekdays, days, 1-31) and magnet shapes.						
13	BVC-GA03107830A ★	15	36" × 24"	Silver	9 lbs. Each	228.97
★ ISO 9001-2008.						

## ADVANTUS

### E CABINET/LOCKER CLIPS

A convenient way to create an effective message center by arranging several clips in one area. Clip comes with magnetic and adhesive mounting options to mount on a variety of surfaces, including walls, cabinets, and lockers. Each clip holds 40 sheets of paper.

ID No.	Color	Width	Qty.	Unit	Price	
14	AVT-75356	White	1"	20	Box	15.44

### F GRIP-A-CLIP MAGNETIC/ADHESIVE CLIPS

Unique roller automatically adjusts the clip's pitch and angle so that it can hold up to 20 sheets of standard weight paper. Two mounting options: magnetic or adhesive, provide the versatility you need to create message centers nearly anywhere. Go magnetic for file cabinets, lockers and refrigerators, or go adhesive for walls, cabinets and doors. Not for use on painted/papered walls.

ID No.	Color	Width	Qty.	Unit	Price	
15	AVT-91172	Gray	1.25"	10	Box	8.34





**new**



**new**



**new**

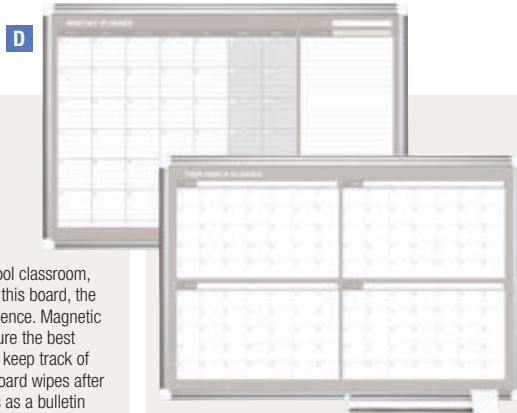

U BRANDS

### A PINIT MAGNETIC DRY ERASE CALENDAR

Perfect and functional solution for the frequent usage areas of your office, school classroom, home or any commercial space. Although all dry erase markers work well with this board, the U Brands dry erase markers provide the ultimate writing and eras-ability experience. Magnetic painted steel writing surface will require minimal ongoing cleaning care to ensure the best performance and resist ink staining and ghosting. Monthly view enables you to keep track of your hectic schedule. Simply use any dry erase board spray or wet dry erase board wipes after continuous use to clean the writing surface. Magnetic writing surface functions as a bulletin board as well; simply use any board magnets to pin all of your notes, messages, pictures, memos, calendars, menus, reminders and more. You may also attach all U Brands magnetic board markers and accessories (sold separately) to the board surface without using the marker tray. Strong and thick insulation underneath the dry erase surface, combined with the aluminum frame provides a firm and rigid construction. Whiteboard has a universal mounting system, as it can be hung horizontally. Mounting Hardware; Instructions.

ID No.	W x H	Frame Color	Shpg. Wt.	Unit	Price
1 UBR-2901U0001	36" x 24"	Silver	9 lbs.	Each	<del>126.00</del>
2 UBR-2902U0001	36" x 36"	Silver	14 lbs.	Each	<del>266.50</del>
3 UBR-2903U0001	48" x 36"	Silver	17 lbs.	Each	<del>266.50</del>

### B 4N1 MAGNETIC DRY ERASE COMBO BOARD

Perfect and functional solution for the frequent and heavy usage areas of your office, school classroom, home or any commercial space. Durable silver aluminum frame adds a clean modern touch to any room setting. Painted steel writing surface. Faint grid line section for notes or small graphs. Built in cork strip enables you to pin important notes and pictures. All ink erases easily with a simple eraser, try U Brands board erasers for ultimate performance. Occasionally, use any dry erase board spray or wet dry erase board wipes after continuous use to clean the writing surface. Although all dry erase markers work well with this board, the U Brands dry erase markers provide the ultimate writing and eras-ability experience. Universal mounting system, as it can be hung horizontally to fit your allocated space. All wall hanging hardware is hidden under the mounting bolts for a sleek and modern appearance. The board is packaged with extra supportive corrugate material that is highly resistant to damage during shipping; all corrugated material can be recycled once unpacked. Mounting Hardware; Instructions.

ID No.	W x H	Frame Color	Shpg. Wt.	Unit	Price
4 UBR-3890U0001	24" x 18"	Silver	5 lbs.	Each	<del>45.99</del>
5 UBR-3891U0001	36" x 24"	Silver	8 lbs.	Each	<del>62.99</del>

### C 3N1 MAGNETIC GLASS DRY ERASE COMBO BOARD

Perfect for heavy use in offices, homes, classrooms and commercial spaces. Contemporary design adds a touch of subtle style to your wall. Features a premium, stain- and ghost-proof, frosted-tempered-glass surface, a built-in felt bar for pinning notes and pictures, rigid construction and an ultra-durable aluminum frame. Works well with all dry erase and glass markers; but for the ultimate writing and erasability experience, use U Brands dry-erase markers as well as board spray and dry-erase wipes to clean the writing surface after use. Mounting Hardware; Instructions.

ID No.	W x H	Frame Color	Shpg. Wt.	Unit	Price
<b>Monthly Calendar Format</b>					
6 UBR-3196U0001	24" x 18"	White	13 lbs.	Each	<del>218.98</del>
7 UBR-3197U0001	36" x 24"	White	18 lbs.	Each	<del>218.98</del>
8 UBR-3198U0001	48" x 36"	White	32 lbs.	Each	<del>375.00</del>
<b>Weekly Calendar Format</b>					
9 UBR-3199U0001	35" x 14.25"	White	16 lbs.	Each	<del>164.65</del>

## MasterVision®

### D MAGNETIC DRY ERASE CALENDAR BOARD

Organization is vital for the success of every business or enterprise. MasterVision® Planning Boards are excellent tools that allow you to keep scheduling and planning on time. Keeping important dates and tasks on display, organizing work-groups or just planning ahead is practical and easy. Magnetic Gold Ultra™ dry erase board allows you to post notes and messages as well as write. The lacquered steel surface is suitable for frequent use. Sturdy aluminum frame features an adjustable aluminum tray and the four-corner system for easy mounting. Includes mounting kit.

ID No.	W x H	Frame Color	Shpg. Wt.	Unit	Price
<b>Weekly Calendar</b>					
10 BVC-GA0396830	36" x 24"	Silver	9 lbs.	Each	<del>148.84</del>
<b>One Month Calendar</b>					
11 BVC-GA0397830	36" x 24"	Silver	9 lbs.	Each	<del>148.84</del>
12 BVC-GA0597830	48" x 36"	Silver	21 lbs.	Each	<del>240.36</del>
<b>Four-Month Calendar</b>					
13 BVC-GA03105830	36" x 24"	Silver	9 lbs.	Each	<del>148.84</del>
14 BVC-GA05105830	48" x 36"	Silver	21 lbs.	Each	<del>240.36</del>
<b>12-Month Calendar</b>					
15 BVC-GA03106830	36" x 24"	Silver	9 lbs.	Each	<del>148.84</del>
16 BVC-GA05106830	48" x 36"	Silver	21 lbs.	Each	<del>240.36</del>

### E 3-IN-1 PLANNER BOARD

Functionality times three. This magnetic dry-erase calendar planner provides space for lists and a bulletin board surface for important cards and notes. Includes mounting kit.

ID No.	W x H	Frame Color	Shpg. Wt.	Unit	Price
17 BVC-MB3507186	24" x 18"	Silver	4 lbs.	Each	<del>45.76</del>
18 BVC-MB0707186P	36" x 24"	Silver	9 lbs.	Each	<del>62.47</del>

Prices subject to change without notice.

Visit our website for the latest pricing and product information.



U BRANDS

## A FLOATING GLASS DRY ERASE CALENDAR

Perfect and functional solution for the frequent and heavy usage areas of your office, school classroom, home or any commercial space. Clean, contemporary and frameless product design lines will add a touch of subtle style to your wall. The modern frameless feature enables you to hang multiple glass boards adjacent to each other and expand the writing surface to fit your custom space needs. Premium ultimate glass writing surface will never stain or ghost. Monthly view enables you to keep track of your hectic schedule. All ink erases easily with a simple eraser and the glass surface continuously outperforms all traditional melamine or painted steel dry erase writing surfaces. Occasionally, use any dry erase board spray or wet dry erase board wipes after continuous use to clean the writing surface. Although all dry erase and glass markers work well with this board, the U Brands dry erase markers provide the ultimate writing and eras-ability experience. For safety, the board is made from tempered glass as well. Modern frameless design includes hidden mounting brackets that give the impression that the board is floating on the wall. The board is packaged with extra supportive corrugate material that is highly resistant to damage during shipping; all corrugated material can be recycled once unpacked. (6) Assorted Liquid Glass Marker; (1) Shag Eraser; Mounting Hardware; Instructions. Manufacturer's limited lifetime warranty.

ID No.	W × H	Color	Shpg. Wt.	Qty.	Unit	Price
1 UBR-3967U0001	36" × 24"	White	16 lbs.	1	Each	<del>139.95</del>
2 UBR-3968U0001	36" × 36"	White	23 lbs.	1	Each	<del>215.99</del>
3 UBR-3969U0001	48" × 36"	White	30 lbs.	1	Each	<del>288.70</del>



**Great Service**

We can help you with selection & solutions.



## B INFINITY™ MAGNETIC GLASS CALENDAR BOARD

Tempered-glass surface, magnetic dry-erase calendar is highly durable and will never ghost or stain. Suitable for frequent use, this one-month calendar board is frameless and has a white finish. Includes one Quartet® dry-erase marker, two rare earth, high power magnets and mounting kit. Manufacturer's 15-year warranty.

ID No.	W × H	Color	Shpg. Wt.	Qty.	Unit	Price
4 QRT-GC2418F	24" × 18"	White	10 lbs.	1	Each	119.66
5 QRT-GC3624F	36" × 24"	White	20 lbs.	1	Each	159.95
6 QRT-GC4836F	48" × 36"	White	41 lbs.	1	Each	333.75

## C PRESTIGE® 2 MAGNETIC TOTAL ERASE® MONTHLY CALENDAR

Total Erase® magnetic calendar board tracks one month at a time. The durable, coated surface will not ghost or stain. Includes one dry-erase marker and mounting kit. Manufacturer's twenty-year warranty.

ID No.	Planning Period	W × H	Frame Color	Shpg. Wt.	Unit	Price
7 QRT-CP32P2	One Month	36" × 24"	Graphite	12 lbs.	Each	178.41
8 QRT-CP43P2	One Month	48" × 36"	Graphite	20 lbs.	Each	286.40

## D PRESTIGE® 2 TOTAL ERASE® THREE-MONTH CALENDAR

Total Erase® sliding calendar board features a durable surface that will not ghost or stain. Tracks three months at once. Includes one Quartet® dry-erase marker and mounting kit. Manufacturer's 7-year warranty.

ID No.	Planning Period	W × H	Frame Color	Shpg. Wt.	Unit	Price
9 QRT-CMP32P2	Three Months	36" × 24"	Graphite	13 lbs.	Each	210.09

## E PRESTIGE® 2 MAGNETIC TOTAL ERASE® FOUR-MONTH CALENDAR

Total Erase® magnetic calendar board features a durable surface that will not ghost or stain. Tracks four months at a time. Includes accessory tray/rail, one dry-erase marker and mounting kit. Manufacturer's 20-year warranty.

ID No.	Planning Period	W × H	Frame Color	Shpg. Wt.	Unit	Price
10 QRT-4MCP23P2	Four Months	36" × 24"	Graphite	12 lbs.	Each	172.52
11 QRT-4MCP43P2	Four Months	48" × 36"	Graphite	20 lbs.	Each	275.86



## MasterVision®

### A CHALK WEEKLY PLANNER

Draw and communicate with style. The planner is the perfect combination for planning and posting important information. Use these chalkboards to effectively visualize your weekly tasks. The highly functional design features a chalk surface with printed days of the week so that you can easily keep important dates and events prominent. The cork strip along the bottom allows you to securely pin cards, notes, or other shared info. Ideal for restaurants, coffee-shops, boutiques and personal spaces. MDF frame with hanging hardware included.

ID No.	W × H	Frame Color	Shpg. Wt.	Unit	Price
1 BVC-PM0329168	23.62" × 15.75"	Black	4 lbs.	Each	32.99

### B MAGNETIC DRY ERASE CALENDAR BOARD

Organization is vital for the success of every business or enterprise. MasterVision® Planning Boards are excellent tools that allow you to keep scheduling and planning on time. Keeping important dates and tasks on display, organizing work-groups or just planning ahead is practical and easy. Magnetic Gold Ultra™ dry erase board allows you to post notes and messages as well as write. The lacquered steel surface is suitable for frequent use. Sturdy aluminum frame features an adjustable aluminum tray and the four-corner system for easy mounting. Includes mounting kit.

ID No.	W × H	Frame Color	Shpg. Wt.	Unit	Price
<b>Weekly Calendar</b>					
2 BVC-GA0396830 ★	36" × 24"	Silver	9 lbs.	Each	<del>148.04</del>
<b>One Month Calendar</b>					
3 BVC-GA0397830 ★	36" × 24"	Silver	9 lbs.	Each	<del>148.04</del>
4 BVC-GA0597830 ★	48" × 36"	Silver	21 lbs.	Each	<del>240.36</del>
<b>Four-Month Calendar</b>					
5 BVC-GA03105830 ★	36" × 24"	Silver	9 lbs.	Each	<del>148.04</del>
6 BVC-GA05105830 ★	48" × 36"	Silver	21 lbs.	Each	<del>240.36</del>
<b>12-Month Calendar</b>					
7 BVC-GA03106830 ★	36" × 24"	Silver	9 lbs.	Each	<del>148.04</del>
8 BVC-GA05106830 ★	48" × 36"	Silver	21 lbs.	Each	<del>240.36</del>
<b>12-Month Calendar (Perpetual)</b>					
9 BVC-GA0594830 ★	48" × 36"	Silver	21 lbs.	Each	<del>240.36</del>

★ ISO 9001-2008.

### C MAGNETIC DRY ERASE CALENDAR

Organization is vital for the success of every business or enterprise. Excellent tool that allows you to keep scheduling and planning on time. Keeping important dates and tasks on display, organizing work-groups or just planning ahead is practical and easy.

ID No.	W × H	Frame Color	Shpg. Wt.	Unit	Price
<b>Three Month Calendar</b>					
10 BVC-GA03204830	36" × 24"	Silver	9 lbs.	Each	<del>150.79</del>

### D IN-OUT MAGNETIC DRY ERASE BOARD

In & Out board features rows for employees or visitors and is perfect for displaying staff schedules. Magnetic Gold Ultra™ lacquered steel dry erase surface is recommended for frequent use. Sliding aluminum pen tray keeps markers and magnetic accessories where you want them. Aluminum frame features the four-corner system for easy mounting. Includes mounting kit. Manufacturer's limited ten-year warranty.

ID No.	W × H	Frame Color	Shpg. Wt.	Unit	Price
11 BVC-GA02109830 ★	24" × 36"	Silver	9 lbs.	Each	<del>208.17</del>
12 BVC-GA01110830 ★	36" × 24"	Silver	9 lbs.	Each	<del>208.17</del>

★ ISO 9001-2008.

### E 3-IN-1 PLANNER BOARD

Functionality times three. This dry-erase calendar planner provides space for lists and a bulletin board surface for important cards and notes. Includes mounting kit.

ID No.	W × H	Frame Color	Shpg. Wt.	Unit	Price
13 BVC-MB3507186 ★	24" × 18"	Silver	4 lbs.	Each	<del>45.76</del>
14 BVC-MB0707186P	36" × 24"	Silver	9 lbs.	Each	<del>62.47</del>

★ ISO 9001-2008.



### F PRESTIGE® 2 MAGNETIC TOTAL ERASE® PROJECT PLANNER

Magnetic Total Erase® planner has a durable surface that will not ghost or stain. Column chart features customizable headers. Includes accessory tray/trail, one dry-erase marker and mounting kit. Manufacturer's 20-year warranty.

ID No.	Columns/Rows	W × H	Frame Color	Shpg. Wt.	Unit	Price
15 QRT-PP32P2	16	36" × 24"	Graphite	12 lbs.	Each	<del>134.96</del>
16 QRT-PP43P2	25	48" × 36"	Graphite	20 lbs.	Each	<del>275.86</del>

### G TACK & WRITE® MONTHLY CALENDAR BOARD

Easy-to-read monthly calendar with smooth writing surface and grid lines for tracking deadlines and to-do lists. Delivers effective performance in low-use personal environments. Flexible mounting system attaches to regular or fabric-covered walls. Includes one Quartet® dry-erase marker. Manufacturer's 1-year warranty.

ID No.	Planning Period	W × H	Frame Color	Shpg. Wt.	Unit	Price
17 QRT-CT2317	One Month	23" × 17"	Black	2 lbs.	Each	<del>62.32</del>

Prices subject to change without notice.  
Visit our website for the latest pricing and product information.

# Office Furnishings Boards/Planning Accessories



U BRANDS

## A HIGH ENERGY MAGNETS

Strong, powerful and multi-purpose, these magnets provide high energy allowing them to magnetize to magnetic glass boards.

ID No.	Height	Color	Qty.	Unit	Price
1 UBR-3021U0012	0.21"	Black	8	Pack	<del>24.99</del>
2 UBR-2911U0012	0.21"	Silver	12	Pack	<del>30.55</del>



## B MAGNETIC "PUSH PINS"

High-powered magnets in the shape of push pins fasten to any magnetic surface to securely hold up to six pages, creating an instant bulletin board. Convenient, clear plastic storage package. Accent messages with brightly colored plastic magnets.

ID No.	Color	Unit	Price
3 QRT-MPPC	Blue; Green; Purple; Red; Yellow	Pack	<del>31.45</del>

## C GLASS MAGNETS

Magnets allow you to take advantage of all the features of any magnetic whiteboard, and are the only magnets that are compatible with a magnetic, glass marker board. Extra strong, these magnets hold more sheets than a standard magnet.

ID No.	Color	Qty.	Unit	Price
4 QRT-85391	Clear	6 per pack	Pack	<del>23.04</del>



## D MAGNETIC CLIPS

Super-strong magnet and spring. Chrome-plated steel construction.

ID No.	Color	Size	Width	Qty.	Unit	Price
5 ACC-72131	Silver	Small	1.5"	1	Each	<del>3.42</del>
6 ACC-72132	Silver	Medium	1.75"	1	Each	<del>4.64</del>
7 ACC-72133	Silver	Large	2.25"	1	Each	<del>7.40</del>



## E ASSORTED MAGNETS

Handy for displaying papers and documents on any magnetic surface — including whiteboards and file cabinets. Three sizes and five assorted colors: Blue, Green, Red, Yellow and White, all packaged in a convenient, reusable storage tub.

ID No.	Color	Qty.	Unit	Price
8 OIC-92500 *	Assorted	30	Pack	<del>7.48</del>
<b>Heavy-Duty</b> —Three times as strong as standard magnets.				
9 OIC-92501 *	Assorted	30	Pack	<del>16.11</del>
* Includes 12 small (3/4" dia.), 12 medium (1 1/8" dia.) and six large (1 1/2" dia.) magnets.				



universal.

## F ASSORTED MAGNETS

Handy for displaying papers and documents. Ideal for magnetic dry-erase boards and regular day-to-day usage. Variety of sizes and colors. Manufacturer's limited one-year warranty.

ID No.	Color	Qty.	Unit	Price
10 UNV-31250 *	Assorted	30	Pack	<del>6.54</del>
* Includes 30 magnetic circles.				

## G BULLDOG MAGNETIC CLIPS

Great for hanging notes or displaying photos on fridges, file cabinets, or steel surface. Heavy-duty construction for long-lasting durability.

ID No.	Color	Size	Width	Qty.	Unit	Price
11 UNV-31260	Silver	Small	1.25"	18	Pack	<del>27.02</del>
12 UNV-31261	Silver	Medium	2.25"	12	Pack	<del>26.59</del>

## H HIGH-INTENSITY ASSORTED MAGNETS

Perfect for displaying papers and documents. High-intensity for magnetic glass boards, ferrous-metal cabinets and heavy-duty applications. Variety of sizes and colors. Manufacturer's limited one-year warranty.

ID No.	Color	Qty.	Unit	Price
13 UNV-31251 *	Assorted	30	Pack	<del>15.74</del>
* Includes 30 magnetic circles.				

## MasterVision®

### I HEAVY-DUTY BOARD MAGNETS

Magnetic accessories make building and maintaining your planning board easier. Arrange data easily and quickly when changes become necessary.

ID No.	Height	Color	Qty.	Unit	Price
<b>Plastic-Covered High-Intensity Magnetic Circles</b>					
14 BVC-IM130809 *	1 1/4"	Silver	10	Pack	<del>15.59</del>
15 BVC-IM140909 *	3/4"	Assorted	10	Pack	<del>15.59</del>
<b>Magnetic Color-Coding Circles</b>					
16 BVC-FM1618 *	3/4"	White	20	Pack	<del>7.27</del>
17 BVC-FM1605 *	3/4"	Black	20	Pack	<del>7.27</del>
18 BVC-FM1601 *	3/4"	Blue	20	Pack	<del>7.27</del>
19 BVC-FM1602 *	3/4"	Green	20	Pack	<del>7.27</del>
20 BVC-FM1604 *	3/4"	Red	20	Pack	<del>7.27</del>
<b>Magnetic Push Pins</b>					
21 BVC-IM356601 *	3/4"	Assorted	6	Pack	<del>13.51</del>

\* BVC-IM130809—Includes 10 magnets.  
 BVC-FM1618, BVC-FM1605, BVC-FM1601, BVC-FM1602, BVC-FM1604—Includes 20 magnetic circles.  
 BVC-IM140909—Includes 10 magnetic circles.  
 BVC-IM356601—Includes six magnetic push pins.

### J MAGNETIC SMARTBOX ORGANIZER

Keep markers, erasers, cleaners, etc. close at hand by placing this magnetic storage accessory on any magnetic board. It has spacious compartments to keep you organized and neat. Everything tidy and in place. 9 x 4.

ID No.	Material	Unit	Price
22 BVC-SM010101 *	Plastic	Each	<del>13.52</del>
* TAA Compliant.			





## A DRY ERASE SURFACE

Transform painted drywall, glass, painted steel, finished wood or even old dry erase boards into a dry erase surface. Easily turn surfaces into dry erase surfaces. Peel-and-stick construction sticks securely and removes cleanly. The stain-proof technology on these high-performance surfaces provides great writability as well as erasability.

ID No.	W x H	Color	Shpg. Wt.	Qty.	Unit	Price
1 MMM-DEF3X2 ★	36" x 24"	White	2 lbs.	1	Each	<del>48.00</del>
2 MMM-DEF4X3 ★	48" x 36"	White	3 lbs.	1	Each	<del>82.22</del>
3 MMM-DEF6X4 ★	72" x 48"	White	4 lbs.	1	Each	<del>162.97</del>
4 MMM-DEF8X4 ★	96" x 48"	White	5 lbs.	1	Each	<del>216.35</del>

★ If the surface you are applying it to resists adhesion, we will provide a complete refund or an adhesion assist kit and replacement product, whichever you prefer. Our customer service team can help and can be reached at 800-395-1223.



## B JUSTICK BY SMEAD® WHITE BOARD WITH FRAME

Can't decide between a whiteboard or corkboard for your office or home? Why not pick a solution that does both. Simply place the items on the surface of the board and they stick without using pins, magnets or tape.

ID No.	W x H	Frame Color	Shpg. Wt.	Unit	Price
5 SMD-02571	36" x 24"	Silver	8 lbs.	Each	<del>299.99</del>
6 SMD-02572 📦	48" x 36"	Silver	14 lbs.	Each	<del>399.99</del>

## C JUSTICK BY SMEAD® COMMERCIAL BOARD

The product line has a series of solutions to engage your customers and create a dynamic brand experience. No pins, magnets, tape or glue required—simply place your documents on the surface and they just stick.

ID No.	W x H	Frame Color	Shpg. Wt.	Unit	Price
7 SMD-02590	72" x 36"	Silver	18 lbs.	Each	<del>649.99</del>



## AT-A-GLANCE®

### D - E WALLMATES™ SELF-ADHESIVE DRY ERASE PLANNING SURFACES

Turn any office wall into an instant planning center. Self-adhesive backing allows quick and easy mounting to any hard, flat surface — just peel, stick and you're done. Removable adhesive leaves no residue and won't damage walls. Versatile dry erase surface with marker included.

### D WALLMATES® SELF-ADHESIVE DRY ERASE PLANNING SURFACES

Designed specifically for weekly, monthly or yearly planning. Dry-erase marker included. Hanger Style: Self-Adhesive.

ID No.	Size	Page Color/Theme	Unit	Price
<b>Weekly Planning Surface</b> —Large, undated daily blocks with Monday start and three-year reference calendar.				
8 AAG-AW503028	18 x 24	Gray/White/Orange	Each	<del>27.89</del>
<b>Monthly Planning Surface</b> —Undated monthly blocks and HOT Spot reminder-notes area with three-year reference calendar.				
9 AAG-AW402028 ★	18 x 12	Gray/White/Orange	Each	<del>19.29</del>
10 AAG-AW502028 ★	24 x 18	Gray/White/Orange	Each	<del>27.89</del>
11 AAG-AW602028 ★	36 x 24	Gray/White/Orange	Each	<del>36.39</del>
<b>Yearly Calendar</b> —Large daily blocks with Sunday start.				
12 AAG-AW506028 ★ 📧	24 x 18	Gray/White/Orange	Each	<del>28.29</del>

★ AAG-AW402028—Block Size: 2<sup>3</sup>/<sub>8</sub>" x 1<sup>1</sup>/<sub>8</sub>".  
 AAG-AW502028—Block Size: 3<sup>3</sup>/<sub>8</sub>" x 2<sup>1</sup>/<sub>8</sub>".  
 AAG-AW602028—Block Size: 4<sup>1</sup>/<sub>8</sub>" x 3<sup>3</sup>/<sub>8</sub>".  
 AAG-AW506028—2019, 12-Month (Jan.-Dec.). Block Size: 3<sup>4</sup>/<sub>8</sub>" x 7<sup>1</sup>/<sub>8</sub>".

### E WALLMATES® SELF-ADHESIVE DRY ERASE WRITING SURFACE

Provides open space for a variety of purposes. Dry-erase marker included. Hanger Style: Self-Adhesive.

ID No.	Size	Page Color/Theme	Unit	Price
13 AAG-AW401028	18 x 12	Gray/White/Orange	Each	<del>19.29</del>
14 AAG-AW501028	24 x 18	Gray/White/Orange	Each	<del>27.89</del>
15 AAG-AW601028	36 x 24	Gray/White/Orange	Each	<del>36.39</del>



# Office Furnishings Boards/Fabric

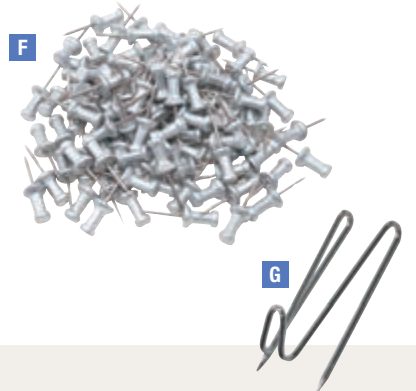
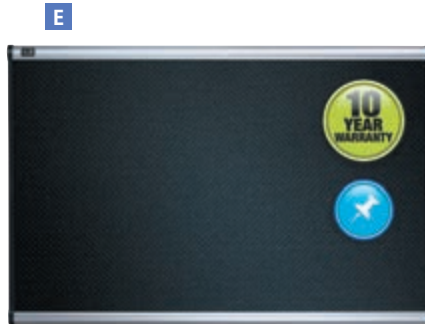
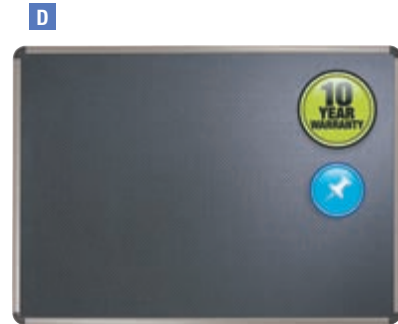

## MasterVision®

### A SOFT-TOUCH BULLETIN BOARD

Deluxe bulletin board features a lush black fabric surface that never shows pin holes. Frame combines aluminum and black plastic. Includes mounting kit.

ID No.	W x H	Frame Color	Shpg. Wt.	Unit	Price
1 BVC-MV1030301 ★	36" x 24"	Aluminum/Black	9 lbs.	Each	114.46
2 BVC-MV1050301 ★	48" x 36"	Aluminum/Black	14 lbs.	Each	183.27
3 BVC-MV1270301 ★	72" x 48"	Aluminum/Black	31 lbs.	Each	343.70
4 BVC-MV1210301 ★	96" x 48"	Aluminum/Black	43 lbs.	Each	435.22

★ ISO 9001-2008.

### D PRESTIGE® EURO™ STYLE BLACK EMBOSSED FOAM BULLETIN BOARD

Highly durable embossed-foam bulletin board backed by high-density fiberboard secures documents with push pins. Self-healing foam surface eliminates pin holes. Includes mounting kit.

ID No.	W x H	Frame Color	Shpg. Wt.	Unit	Price
17 QRT-B363T	36" x 24"	Euro Titanium	9 lbs.	Each	130.84
18 QRT-B364T	48" x 34 7/16"	Euro Titanium	16 lbs.	Each	210.50
19 QRT-B367T	72" x 48"	Euro Titanium	32 lbs.	Each	492.76

### E PRESTIGE® BLACK EMBOSSED FOAM BULLETIN BOARD

Highly durable embossed black-foam bulletin board backed by high-density fiberboard secures documents with push pins. Self-healing foam surface eliminates pin holes. Mounting kit included.

ID No.	W x H	Frame Color	Shpg. Wt.	Unit	Price
20 QRT-B343A	36" x 24"	Silver	9 lbs.	Each	118.30
21 QRT-B344A	48" x 36"	Silver	16 lbs.	Each	186.61
22 QRT-B347A	72" x 48"	Silver	32 lbs.	Each	444.96

## quartet.

### B PRESTIGE PLUS® MAGNETIC FABRIC BULLETIN BOARDS

Ultra-durable, magnetic fabric bulletin board backed by high-density fiberboard secures documents with push pins or magnets. Delivers superior performance in heavy-use offices and conference rooms. Self-healing surface. Includes Quartet® Quick Clips, magnets and mounting kit.

ID No.	W x H	Frame Color	Shpg. Wt.	Unit	Price
5 QRT-MB543M	36" x 24"	Mahogany	10 lbs.	Each	195.72
6 QRT-MB543A	36" x 24"	Silver	10 lbs.	Each	195.72
7 QRT-MB544M	48" x 36"	Mahogany	18 lbs.	Each	314.08
8 QRT-MB544A	48" x 36"	Silver	18 lbs.	Each	314.08
9 QRT-MB547M	72" x 48"	Mahogany	36 lbs.	Each	645.30
10 QRT-MB547A	72" x 48"	Silver	36 lbs.	Each	645.30

### C PRESTIGE® GRAY DIAMOND MESH BULLETIN BOARD

Highly durable, densely woven diamond-mesh bulletin board backed by high-density fiberboard secures documents with push pins. Self-healing surface eliminates pin holes. Includes mounting kit.

ID No.	W x H	Frame Color	Shpg. Wt.	Unit	Price
11 QRT-B443M	36" x 24"	Mahogany	10 lbs.	Each	138.80
12 QRT-B443A	36" x 24"	Silver	10 lbs.	Each	138.80
13 QRT-B444M	48" x 36"	Mahogany	17 lbs.	Each	221.90
14 QRT-B444A	48" x 36"	Silver	17 lbs.	Each	221.90
15 QRT-B447M	72" x 48"	Mahogany	30 lbs.	Each	537.17
16 QRT-B447A	72" x 48"	Silver	30 lbs.	Each	537.17

## GEM™ Office Products Company

### F ALUMINUM HEAD PUSH PINS

Quality aluminum head with a strong steel pin. The smooth extended head and sharp point allow these push pins to be inserted into the toughest surfaces. Easy to remove without harming fingers.

ID No.	Length	Color	Head Diameter	Qty.	Unit	Price
23 GEM-CPAL3	3/8"	Silver	3/16"	100	Box	6.49
24 GEM-CPAL4	1/2"	Silver	3/16"	100	Box	6.79
25 GEM-CPAL5	5/8"	Silver	3/16"	100	Box	6.99

## ADVANTUS

### G PANEL WALL WIRE HOOKS

Metal wire hangers for lightweight objects. Hang pictures, calendars or keys on fabric panel walls. Wire hangers also clip notes or memos between hanger and panel.

ID No.	Finish	W x D x H	Hook Material	Qty.	Unit	Price
26 AVT-75370	Silver	3 1/2" x 1" x 2 1/2"	Metal Wire	25	Pack	7.49



## MasterVision®

### A TECH CORK BOARD

Tech cork is a special self-healing bulletin board surface based on a fine blend of cork and rubber. Thick and extremely resilient, the unusual surface offers a texture that gives these boards a contemporary look while providing years of use. Contemporary aluminum and plastic frame enhances any office environment.

ID No.	W × H	Frame Color	Shpg. Wt.	Unit	Price
1 BVC-MVI030501 ★	36" × 24"	Silver/Black	7 lbs.	Each	<del>83.24</del>
2 BVC-MVI050501 ★	48" × 36"	Silver/Black	14 lbs.	Each	<del>121.87</del>
3 BVC-MVI270501 ★	72" × 48"	Silver/Black	31 lbs.	Each	<del>325.97</del>

★ ISO 9001-2008.



### B DESIGNER CORK BULLETIN BOARD

Upscale contemporary large-grain natural cork board. Self-healing surface seamlessly wraps over side edges at 1.5" depth. Integrated mounting corner brackets enable secure, modular horizontal or vertical mounting. Includes mounting hardware.

ID No.	W × H	Shpg. Wt.	Unit	Price
4 ICE-35016	18" × 18"	4 lbs.	Each	64.95
5 ICE-35014	20" × 24"	8 lbs.	Each	89.95
6 ICE-35010	24" × 38"	11 lbs.	Each	99.95

## MasterVision®

### C NATURAL CORK BULLETIN BOARD

Design, functionality and texture feature prominently in this beautiful natural cork bulletin board. Designed to fit in smaller spaces, MasterVision® personal home and office products can be used in any working context. Practical and adaptable, they're the starting point for all efficient planning and organization projects, boosting performance for both teams and individuals. Includes mounting kit. 📦

ID No.	W × H	Frame Color	Shpg. Wt.	Unit	Price
7 BVC-SF0422581012 ★	24" × 18"	Black	4 lbs.	Each	68.66
8 BVC-SF0722581012 ★	36" × 24"	Black	6 lbs.	Each	114.43

★ ISO 9001-2008.

## universal.

### D CORK TILE PANELS

Convenient tiles allow you to create custom cork boards; the tiles fit any wall. One foot square tiles are 3/8" deep to accept most common push pins. They're great for lining a wall because of their excellent noise-absorbing qualities. Includes mounting tape. Manufacturer's limited one-year warranty.

ID No.	W × H	Color	Shpg. Wt.	Qty.	Unit	Price
<b>Classic Cork Facing</b>						
9 UNV-43404	12" × 12"	Brown	2 lbs.	4	Pack	22.99
<b>Real Cork Fragments—For a more natural look.</b>						
10 UNV-43403	12" × 12"	Dark Brown	3 lbs.	4	Pack	<del>30.75</del>

## MasterVision®

### E SLIM-LINE ENCLOSED FABRIC BULLETIN BOARD

Enclosed fabric bulletin board showcases information in a beautiful way. Clear, locking door provides security and protection. Perfect for menus, schedules, timetables and other vital posting. Features include an anodized aluminum frame, a fire-retardant felt surface and a strong acrylic door.

ID No.	Description	W × H	Frame Color	Shpg. Wt.	Unit	Price
<b>One Door</b>						
11 BVC-VT630103690 ★	One Door	28" × 38"	Aluminum	14 lbs.	Each	343.44

★ ISO 9001-2008.

### F SLIM-LINE ENCLOSED CORK BULLETIN BOARD

Enclosed cork bulletin board showcases information in a beautiful way. Clear, locking door provides security and protection. Perfect for menus, schedules, timetables and other vital posting. Features include an anodized aluminum frame and a strong acrylic door.

ID No.	Description	W × H	Frame Color	Shpg. Wt.	Unit	Price
<b>One Door</b>						
12 BVC-VT630101690 ★	One Door	28" × 38"	Aluminum	14 lbs.	Each	343.44

★ ISO 9001-2008.

Prices subject to change without notice.  
Visit our website for the latest pricing and product information.

# Office Furnishings Boards/Fabric & Cork

**A**

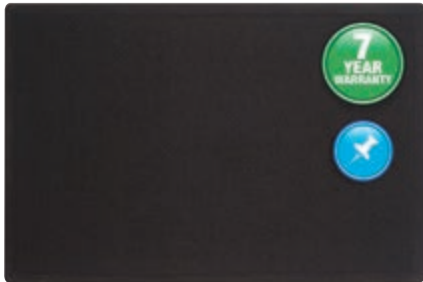

**B**

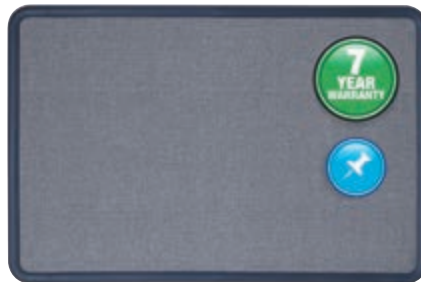

**C**



**D**

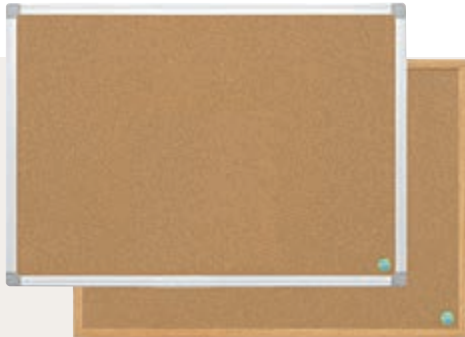

**E**



**F**



**G**



## A OVAL OFFICE™ FABRIC BOARD

Highly durable frameless bulletin board backed by high-density fiberboard features edge-to-edge posting surface for securing documents with push pins. Delivers quality performance in frequent-use offices and conference rooms. Moisture-resistant backing. Includes mounting kit. Manufacturer's seven-year warranty.

ID No.	W × H	Color	Shpg. Wt.	Qty.	Unit	Price
1 QRT-7683BK	36" × 24"	Black	5 lbs.	1	Each	<del>131.91</del>
2 QRT-7683G	36" × 24"	Gray	8 lbs.	1	Each	<del>131.83</del>
3 QRT-7684BK	48" × 36"	Black	10 lbs.	1	Each	<del>193.94</del>
4 QRT-7684G	48" × 36"	Gray	19 lbs.	1	Each	<del>193.94</del>

## B CONTOUR® FABRIC BULLETIN BOARD

Highly durable fabric bulletin board surface backed by high-density fiberboard secures documents with push pins. Delivers quality performance in frequent-use offices and conference rooms. Self-healing surface eliminates pin holes. Includes mounting kit.

ID No.	W × H	Frame Color	Shpg. Wt.	Unit	Price
5 QRT-7693G	36" × 24"	Black	7 lbs.	Each	<del>98.44</del>
6 QRT-7693BE	36" × 24"	Navy Blue	7 lbs.	Each	<del>98.35</del>
7 QRT-7694G	48" × 36"	Black	9 lbs.	Each	<del>140.02</del>
8 QRT-7694BE	48" × 36"	Navy Blue	9 lbs.	Each	<del>139.74</del>

## MasterVision®

### C VALUE CORK BULLETIN BOARD WITH ALUMINUM FRAME

Cork surface is self-healing and will provide years of use. The aluminum frame has an easy four-corner mounting system and can be mounted vertically or horizontally. Includes hanging hardware, instructions.

ID No.	W × H	Frame Color	Shpg. Wt.	Unit	Price
9 BVC-CA031170 ★	24" × 36"	Silver	7 lbs.	Each	<del>61.04</del>
10 BVC-CA051170 ★	36" × 48"	Silver	12 lbs.	Each	<del>80.30</del>
11 BVC-CA271170 ★	48" × 72"	Silver	24 lbs.	Each	<del>241.08</del>
12 BVC-CA211170 ★	48" × 96"	Silver	32 lbs.	Each	<del>286.87</del>

★ ISO Compliant.

### D EARTH CORK BOARD

Bulletin board is an efficient and versatile solution for visual communication. Decorative and practical, it's a tool that serves as an important aid to sharing information. Manufactured using post-consumer and post-industrial waste, it's also nearly entirely recyclable. Real cork surface is extremely durable and resilient. Sturdy aluminum frame features an easy to mount four-corner system. Includes mounting kit.

ID No.	W × H	Frame Color	Shpg. Wt.	Unit	Price
13 BVC-CA021790 ★	24" × 18"	Silver	4 lbs.	Each	<del>68.68</del>
14 BVC-SB0420001233 ★	36" × 24"	Oak	6 lbs.	Each	<del>63.49</del>
15 BVC-CA031790 ★	36" × 24"	Silver	6 lbs.	Each	<del>80.17</del>
16 BVC-SB0720001233 ★	48" × 36"	Oak	8 lbs.	Each	<del>126.11</del>
17 BVC-CA051790 ★	48" × 36"	Silver	12 lbs.	Each	<del>126.13</del>
18 BVC-SB1420001233 ★	72" × 48"	Oak	25 lbs.	Each	<del>275.07</del>
19 BVC-CA271790 ★	72" × 48"	Silver	25 lbs.	Each	<del>297.98</del>

★ Cradle to Cradle Certified™ Silver, ISO 9001-2008.

## universal.

### E CLEAR PUSH PINS

Clear plastic head allows you to tack up important documents and posters without unwanted visual distractions. Steel pin glides right into even the toughest surfaces: drywall, plaster and mat-board as well as cork and foam. Steel.

ID No.	Length	Color	Head Diameter	Qty.	Unit	Price
20 UNV-31306	¾"	Clear	¼"	400	Pack	<del>14.58</del>

### F COLORED PUSH PINS

Secure important documents to walls and bulletin boards. Assorted color heads with strong steel pins can push through most surfaces. Steel.

ID No.	Length	Color	Head Diameter	Qty.	Unit	Price
21 UNV-31314 ★	¾"	Assorted	¼"	400	Pack	<del>14.58</del>

★ Blue; Green; Red; White; Yellow.

### G THUMB TACKS

Thumb tacks feature smooth heads and sharp points. Ideal for corkboards. ¾" length.

ID No.	Head	Material	Color	Qty.	Unit	Price
22 UNV-51002	¾"	Nickel-Plated Steel	Silver	100	Box	<del>1.14</del>





## A CLASSIC SERIES CORK BULLETIN BOARD

Natural cork bulletin board creates a convenient display center. Cork surface self-heals for lasting durability. Durable frames with heavy-duty mounting systems hold steady for years to come. Affordable and functional. Includes mounting hardware and simple hanging instructions.

ID No.	W × H	Frame Color	Shpg. Wt.	Unit	Price
<b>Black Aluminum Frame</b>					
1 QRT-2301B	24" × 18"	Black	6 lbs.	Each	42.91
2 QRT-2303B	36" × 24"	Black	9 lbs.	Each	62.53
3 QRT-2304B	48" × 36"	Black	11 lbs.	Each	110.34
4 QRT-2305B	60" × 36"	Black	23 lbs.	Each	175.22
5 QRT-2307B	72" × 48"	Black	24 lbs.	Each	238.97
6 QRT-2308B	96" × 48"	Black	40 lbs.	Each	331.14
<b>Silver Aluminum Frame</b>					
7 QRT-2301	24" × 18"	Silver	4 lbs.	Each	42.76
8 QRT-2303	36" × 24"	Silver	6 lbs.	Each	62.53
9 QRT-2304	48" × 36"	Silver	12 lbs.	Each	110.34
10 QRT-2305	60" × 36"	Silver	17 lbs.	Each	175.22
11 QRT-2307	72" × 48"	Silver	29 lbs.	Each	238.97
12 QRT-2308	96" × 48"	Silver	37 lbs.	Each	331.14
<b>Oak Finish Frame</b>					
13 QRT-301	24" × 18"	Oak	4 lbs.	Each	47.03
14 QRT-303	36" × 24"	Oak	7 lbs.	Each	70.46
15 QRT-304	48" × 36"	Oak	14 lbs.	Each	124.32
16 QRT-305	60" × 36"	Oak	19 lbs.	Each	210.50
17 QRT-307	72" × 48"	Oak	30 lbs.	Each	298.15
18 QRT-308	96" × 48"	Oak	40 lbs.	Each	393.75
<b>Oak Finish Frame—Narrow shape fits where others won't.</b>					
19 QRT-300	12" × 36"	Oak	5 lbs.	Each	50.45

## B PRESTIGE® COLORED CORK BULLETIN BOARD

Highly durable cork bulletin board backed by high-density fiberboard secures documents with push pins. Delivers quality performance in high-profile, frequent-use offices and conference rooms. Self-healing surface eliminates pin holes. Includes mounting kit.

ID No.	W × H	Frame Color	Shpg. Wt.	Unit	Price
20 QRT-B243G	36" × 24"	Graphite Gray	9 lbs.	Each	91.00
21 QRT-B243LC	36" × 24"	Light Cherry	9 lbs.	Each	91.00
22 QRT-B244G	48" × 36"	Graphite Gray	16 lbs.	Each	150.18
23 QRT-B244LC	48" × 36"	Light Cherry	16 lbs.	Each	150.18
24 QRT-B247G	72" × 48"	Graphite Gray	32 lbs.	Each	364.16
25 QRT-B247LC	72" × 48"	Light Cherry	32 lbs.	Each	364.16



## C WIDESCREEN CORK BOARD

Graphite-blend, self-healing cork board provides a professional appearance. Aluminum frame with wood grain finish. 48" × 36" and smaller boards require no special hardware or tools when mounted on appropriate surfaces. Includes mounting brackets and Command™ Picture Hanging Strips.

ID No.	W × H	Frame Color	Shpg. Wt.	Unit	Price
<b>Command™ Self Mounting System—No tools required.</b>					
26 MMM-C3624MY	36" × 24"	Mahogany	9 lbs.	Each	90.52
27 MMM-C4836MY	48" × 36"	Mahogany	16 lbs.	Each	154.00
<b>Interlocking Fasteners System</b>					
28 MMM-C7248MY	72" × 48"	Mahogany	33 lbs.	Each	373.97

## MasterVision®

### D NATURAL CORK BULLETIN BOARD

Design, functionality and texture feature prominently in this beautiful natural cork bulletin board. Designed to fit in smaller spaces, MasterVision® personal home and office products can be used in any working context. Practical and adaptable, they're the starting point for all efficient planning and organization projects, boosting performance for both teams and individuals. Includes mounting kit.

ID No.	W × H	Frame Color	Shpg. Wt.	Unit	Price
29 BVC-SF0422581012	24" × 18"	Black	4 lbs.	Each	68.66
30 BVC-SF0722581012	36" × 24"	Black	6 lbs.	Each	114.43

\* ISO 9001-2008.

Prices subject to change without notice.  
Visit our website for the latest pricing and product information.

# Office Furnishings Boards/Cork



## ADVANTUS

### A GRIP-A-STRIP® DISPLAY RAILS

Streamlined alternative to bulletin boards. System of interlocking rollers grip non-laminated documents up to 1/8" thick with gentle pressure, without tacks, pins or tape. Won't damage papers. Mount with included tape or mounting brackets.

ID No.	W × H	Color	Unit	Price
1 AVT-1025	12" × 1½"	Satin Aluminum	Each	10.77
2 AVT-2000	24" × 1½"	Satin Aluminum	Each	19.42
3 AVT-2005	36" × 1½"	Satin Aluminum	Each	29.16
4 AVT-2010	48" × 1½"	Satin Aluminum	Each	34.57
5 AVT-2015	96" × 1½"	Satin Aluminum	Each	62.70

## universal.

### B CORK BOARD WITH ALUMINUM FRAME

Resilient natural cork is self-healing for long-lasting performance. Dense fiberboard backing adds durability. Smooth aluminum frame with black-plastic corner accents. Mounts vertically or horizontally. Includes mounting kit.

ID No.	W × H	Frame Color	Shpg. Wt.	Unit	Price
6 UNV-43712 ★	24" × 18"	Aluminum	4 lbs.	Each	46.96
7 UNV-43713 ★	36" × 24"	Aluminum	9 lbs.	Each	72.83
8 UNV-43714 ★	48" × 36"	Aluminum	13 lbs.	Each	106.86

★ ISO 9001-2008.

### C TECH CORK BOARD

Perfect for personal work areas. Sleek heavy duty black frame with unique corners and a combination of rubber and cork that adds extra durability. Easy to mount vertically or horizontally.

ID No.	W × H	Frame Color	Shpg. Wt.	Unit	Price
9 UNV-43021 ★	24" × 18"	Black	4 lbs.	Each	41.19
10 UNV-43022 ★	36" × 24"	Black	7 lbs.	Each	56.64
11 UNV-43023 ★	48" × 36"	Black	12 lbs.	Each	101.96

★ ISO 9001-2008.

### D CORK BOARD WITH OAK STYLE FRAME

A stylish, classic design paired with old-school durability. Board features a self-healing all-natural cork surface and a thick fiberboard backing. Attractive oak-finished, ¾"-wide, mitered-corner frame. Includes mounting kit.

ID No.	W × H	Frame Color	Shpg. Wt.	Unit	Price
12 UNV-43602	24" × 18"	Oak	4 lbs.	Each	34.45
13 UNV-43603	36" × 24"	Oak	8 lbs.	Each	51.99
14 UNV-43604	48" × 36"	Oak	13 lbs.	Each	95.51

### E CORK BULLETIN BOARD

Resilient self-healing all-natural cork. Satin-finished, wrap-around aluminum frame. Dense fiberboard backing.

ID No.	W × H	Frame Color	Shpg. Wt.	Unit	Price
15 UNV-43612	24" × 18"	Aluminum	4 lbs.	Each	33.62
16 UNV-43613	36" × 24"	Aluminum	7 lbs.	Each	53.01
17 UNV-43614	48" × 36"	Aluminum	12 lbs.	Each	87.79



U BRANDS

### F FASHION SPHERE PUSH PINS

Sphere push pins with plastic head and metal prong provide excellent assistance in pinning your important papers and messages while keeping you organized. Steel.

ID No.	Length	Color	Head Diameter	Qty.	Unit	Price
18 UBR-3084U0624 ★	7/16"	Assorted	3/8"	200	Pack	17.50
<b>Rose Gold Pin</b>						
19 UBR-3089U0624	7/16"	Clear	3/8"	100	Pack	11.00

★ UBR-3084U0624—Black; Gold; White.

### G MAP PUSH PINS

These assorted bright color map pins provide excellent assistance in pinning your important papers and messages while keeping you organized. Steel.

ID No.	Length	Color	Head Diameter	Qty.	Unit	Price
20 UBR-3086U0624 ★	1/2"	Assorted	3/16"	300	Pack	10.25

★ Blue; Green; Pink; Yellow.

### H FASHION PUSH PINS

Fashion push pins provide excellent assistance in pinning your important papers and messages while keeping you organized. Steel.

ID No.	Length	Color	Head Diameter	Qty.	Unit	Price
21 UBR-3083U0624	3/8"	Gold	7/8"	36	Pack	19.50
22 UBR-3085U0624 ★	3/8"	Assorted	1/4"	100	Pack	14.25

★ UBR-3085U0624—Brown; Natural.

### I STANDARD PUSH PINS

These clear head push pins provide excellent assistance in pinning your important papers and messages while keeping you organized. Steel.

ID No.	Length	Color	Head Diameter	Qty.	Unit	Price
<b>Gold Pin</b>						
23 UBR-3087U0624	7/16"	Clear/Gold	3/8"	100	Pack	11.00
<b>Silver Pin</b>						
24 UBR-3088U0624	7/16"	Clear/Silver	3/8"	200	Pack	8.40

### J FASHION METAL THUMB TACKS

Metal thumbtacks with metal prong provide excellent assistance in pinning your important papers and messages while keeping you organized. 3/8" length.

ID No.	Head	Material	Color	Qty.	Unit	Price
25 UBR-3092U0624	7/16"	Steel	Brass	200	Pack	6.50
26 UBR-3091U0624	7/16"	Steel	Gold	200	Pack	6.50
<b>Rose Gold Pin</b>						
27 UBR-3090U0624	7/16"	Steel	Marble/Rose Gold	100	Pack	13.25



## MasterVision®

### A CUBICLE WORKSTATION DRY ERASE BOARD

Personal desktop boards are specially designed to be used in cubicle spaces. Ideal tools to organize personal work, they are small, practical and allow writing and posting of small notes. Easy to hang up and can be easily moved. Includes mounting kit.

ID No.	W × H	Frame Color	Shpg. Wt.	Unit	Price
1 BVC-MA10007705 *	36" × 18"	Black	8 lbs.	Each	<del>197.40</del>
<b>Combination Board</b> —Features magnetic dry erase and cork surfaces.					
2 BVC-XA10003700 *	36" × 18"	Aluminum	8 lbs.	Each	<del>148.84</del>
3 BVC-XA42003700 *	48" × 18"	Aluminum	8 lbs.	Each	<del>183.20</del>

\* ISO 9001-2008.

### B MAGNETIC CALENDAR COMBO BOARD

Cubicle workstation combo features a calendar, a white board and a cork board. The white board has a magnetic lacquered steel surface and an aluminum frame. Designed to fit in smaller spaces, MasterVision® personal home and office products can be used in any working context. Practical and adaptable, they're the starting point of all efficient planning and organization, boosting performance for both individuals and teams. Hanging hardware included.

ID No.	W × H	Frame Color	Shpg. Wt.	Unit	Price
<b>Calendar Combination Board</b> —Includes magnetic dry erase and cork surfaces.					
4 BVC-XA429993700 *	48" × 18"	Aluminum	8 lbs.	Each	<del>286.15</del>

\* ISO 9001-2008.

### C DESIGNER FABRIC BULLETIN BOARD

Durable, thick textured fabric bulletin board surface never shows pin holes. Designed to fit in smaller spaces, MasterVision® personal home and office products can be used in any working context. Practical and adaptable, they're the starting point for all efficient planning and organization, boosting performance either in individual or team work. Personal boards are offered in lightweight, convenient and ingenious formats that fit every space. Includes mounting kit.

ID No.	W × H	Frame Color	Shpg. Wt.	Unit	Price
<b>Combination</b> —Fabric bulletin/magnetic silver dry erase.					
5 BVC-MX04433168 *	24" × 18"	Black	3 lbs.	Each	<del>54.64</del>
6 BVC-MX04331608 *	24" × 18"	Gray	3 lbs.	Each	<del>54.64</del>
<b>Fabric Bulletin</b>					
7 BVC-FB0471168 *	24" × 18"	Black	3 lbs.	Each	<del>57.25</del>
8 BVC-FB0470608 *	24" × 18"	Gray	3 lbs.	Each	<del>57.25</del>

\* ISO 9001-2008.

## quartet.

### D ARC™ FRAME CUBICLE BOARD

Durable board delivers quality performance in personal workstations. Flexible mounting system secures to cubicles or dry-wall. Aluminum ARC™ frame. Includes mounting kit.

ID No.	W × H	Frame Color	Shpg. Wt.	Unit	Price
<b>Cork Board</b> —Self-healing graphite-blend cork surface hides pinholes and blemishes and provides a lasting durable surface.					
9 QRT-ARCB3018	30" × 18"	Silver	6 lbs.	Each	<del>61.58</del>
<b>Magnetic Dry Erase Board</b> —Doubles as bulletin board and erases fast, with no staining or ghosting.					
10 QRT-ARC1411	14" × 11"	Silver	2 lbs.	Each	<del>31.92</del>
11 QRT-ARC2414	24" × 14"	Silver	4 lbs.	Each	<del>70.74</del>
12 QRT-ARC3018	30" × 18"	Silver	6 lbs.	Each	<del>90.16</del>
<b>One Month Magnetic Dry Erase Planning Board</b> —Plan your monthly itinerary more efficiently. Surface doubles as bulletin board.					
13 QRT-ARCCP3018	30" × 18"	Silver	6 lbs.	Each	<del>61.58</del>

### E COMBINATION BOARD

Durable combination board with smooth writing surface and self-healing cork bulletin board. Delivers effective performance in low-use personal environments. Flexible mounting system secures board vertically or horizontally. Durable oak-finish frame. Includes accessory tray/rail, one dry-erase marker and mounting kit.

ID No.	W × H	Frame Color	Shpg. Wt.	Unit	Price
14 QRT-S553	36" × 24"	Oak	9 lbs.	Each	<del>109.21</del>
15 QRT-S554	48" × 36"	Oak	14 lbs.	Each	<del>160.49</del>

## universal.

### F COMBINATION DRY ERASE & BULLETIN BOARD

A great combination—versatile board is one half dry-erase magnetic lacquered steel writing surface and one half natural-cork bulletin surface. Satin-finished aluminum frame features attractive plastic corner accents. Includes accessory tray/rail and mounting kit.

ID No.	W × H	Frame Color	Shpg. Wt.	Unit	Price
16 UNV-43742	24" × 18"	Aluminum/Black	5 lbs.	Each	<del>55.03</del>
17 UNV-43743	36" × 24"	Aluminum/Black	8 lbs.	Each	<del>82.17</del>

Prices subject to change without notice.

Visit our website for the latest pricing and product information.

# Office Furnishings Boards/Cubicle/Personal



## A HANGING FILE POCKET WITH DRY ERASE BOARD

Dual-purpose, three-pocket vertical filing system with built-in 11" x 13" magnetic whiteboard allows you to broadcast information and efficiently manage paper flow in your personal workspace. Two removable partitions convert the file pockets into one, two or three letter-size compartments. Hangs over most cubicle panel systems and mounts onto dry-wall surfaces. Built-in marker tray. Includes mounting hardware.

ID No.	Pocket(s)	Size	Color	Unit	Price
1 QRT-OFD	3	Letter	Black	Each	94.74

## B MOTION® PORTABLE DRY ERASE MARKER BOARD

Durable, mobile whiteboard with smooth writing surface designed for organizing daily tasks and on-the-go presentations in contemporary work environments. Lightweight for easy transport. Built-in swivel hangers attach to most office surfaces. Includes one dry-erase marker, one board eraser and mounting kit.

ID No.	W x H	Frame Color	Shpg. Wt.	Unit	Price
2 QRT-MMP25	24" x 18"	Black	2 lbs.	Each	89.90
3 QRT-MMP75	36" x 24"	Black	5 lbs.	Each	103.85

## C MATRIX® MAGNETIC BOARDS

Thin-profile, modular whiteboard with magnetic surface doubles as a bulletin board. Delivers quality performance in any office environment. Innovative mounting system ensures secure vertical or horizontal hanging and makes side-by-side mounting alignment flawless. Includes marker tray, one dry-erase marker and mounting kit.

ID No.	W x H	Frame Color	Shpg. Wt.	Unit	Price
4 QRT-M1616	16" x 16"	Silver	3 lbs.	Each	47.90
5 QRT-M2316	23" x 16"	Silver	4 lbs.	Each	58.17
6 QRT-M2323	23" x 23"	Silver	6 lbs.	Each	73.01
7 QRT-M3423	34" x 23"	Silver	9 lbs.	Each	95.84
8 QRT-M4831	48" x 31"	Silver	16 lbs.	Each	142.67

## D PRESTIGE® CUBICLE TOTAL ERASE® WHITEBOARD

Highly durable whiteboard with Total Erase® surface resists staining and ghosting. Delivers superior performance in personal workstations. Subtle grid helps align writing. Mounts directly to cubicle wall. Includes attachable marker tray, one Quartet® dry-erase marker, mistake-proof hanging system with installation hardware.

ID No.	W x H	Frame Color	Shpg. Wt.	Unit	Price
9 QRT-WM3618	36" x 18"	Graphite	12 lbs.	Each	164.37
10 QRT-WM4818	48" x 18"	Graphite	17 lbs.	Each	197.40

## E TACK & WRITE® BOARD

Delivers effective performance in personal workstations. Flexible mounting system secures to cubicles or dry-wall. Includes one Quartet® dry-erase marker.

ID No.	W x H	Frame Color	Shpg. Wt.	Unit	Price
<b>COMBINATION MARKER BOARD</b> —Half dry erase surface, half black foam surface.					
11 QRT-06545BK	35" x 23½"	Black	13 lbs.	Each	60.27
<b>DRY ERASE MARKER BOARD</b> —Narrow black foam surface at bottom of board.					
12 QRT-06355BK	23½" x 17½"	Black	12 lbs.	Each	49.10

## F ADJUSTABLE CUBICLE PANEL HANGERS

Optimize work spaces and increase opportunities for collaboration. Hang Quartet® aluminum-frame whiteboards and bulletin boards with ease. Adjustable hangers fit over cube walls measuring 1½" to 3" thick. Two hangers per set.

ID No.	Color	W x D x H	Qty.	Unit	Price
13 QRT-7502	Aluminum/Black	½" x 3½" x 1¾"	2	Set	20.62

## G FLEXIBLE METAL CUBICLE PANEL HANGERS

Cubicle partition hangers make it easy to securely attach whiteboards and bulletin boards to cube walls measuring between 1½" and 2½" thick. Compatible with Quartet® Oval Office™ fabric bulletin boards and most Quartet® aluminum-frame whiteboards. Silver, nickel-plated finish matches board frames and the décor of most contemporary offices. Two hangers per set.

ID No.	Color	W x D x H	Qty.	Unit	Price
14 QRT-7501	Silver	1¼" x 2¼" x 2¼"	2	Set	21.57

## H CUBICLE PARTITION HANGERS

Metal partition hangers fit snugly over cubicle walls to properly secure Matrix® whiteboards or bulletin boards in a personal workspace. Set of two hangers.

ID No.	Color	W x D x H	Qty.	Unit	Price
15 QRT-MCH10	Black	1¼" x 2¼" x 2¼"	2	Set	23.20



**Fast Delivery**

In most cases, the next business day!



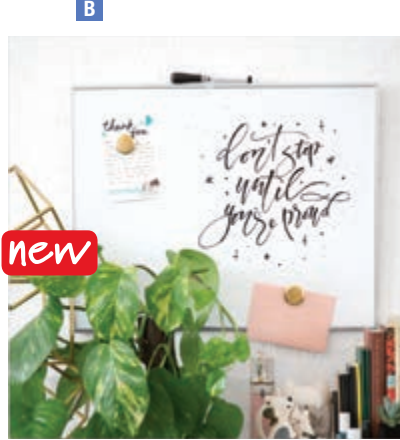
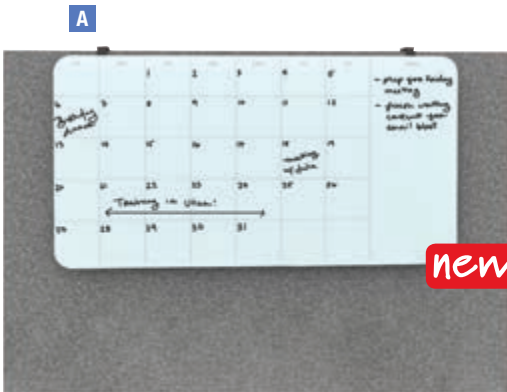

U BRANDS

## A CUBICLE GLASS DRY ERASE BOARD

Perfect and functional solution for your work cubicle. Use the included adjustable cubicle hooks to cleanly hang the glass board over your cubicle wall. Clean, contemporary and frameless product design lines will add a touch of subtle style to your work-space. Premium ultimate glass writing surface will never stain or ghost. All ink erases easily with a simple eraser and the glass surface continuously outperforms all traditional melamine or painted steel dry erase writing surfaces. Occasionally, use any dry erase board spray or wet dry erase board wipes after continuous use to clean the writing surface. Although all dry erase markers work well with this board, the U Brands dry erase markers provide the ultimate writing and eras-ability experience. Mounting Hardware; Instructions. Manufacturer's limited lifetime warranty.

ID No.	W x H	Color	Shpg. Wt.	Qty.	Unit	Price
1 UBR-3688U0001	20" x 5.5"	White	3 lbs.	1	Each	27-00
2 UBR-3687U0001	23" x 12"	White	7 lbs.	1	Each	58-50

## B MAGNETIC DRY ERASE BOARD

Perfect and functional solution for the frequent usage areas of your office, school classroom, home or any commercial space. Although all dry erase markers work well with this board, the U Brands dry erase markers provide the ultimate writing and eras-ability experience. Magnetic painted steel writing surface will require minimal ongoing cleaning care to ensure the best performance and resist ink staining and ghosting. Simply use any dry erase board spray or wet dry erase board wipes after continuous use to clean the writing surface. Magnetic writing surface functions as a bulletin board as well; simply use any board magnets to pin all your notes, messages, pictures, memos, calendars, menus, reminders and more. Dry Erase Marker with Eraser; Magnet; Mounting Hardware; Instructions.

ID No.	W x H	Frame Color	Shpg. Wt.	Unit	Price
3 UBR-356U0001	20" x 16"	Silver	4 lbs.	Each	26-20
4 UBR-361U0001	20" x 16"	Silver	4 lbs.	Each	26-04

# universal.

## C LAP/LEARNING DRY-ERASE BOARD

Convenient lap boards for school, customer displays, or quick visual communication. Double-sided hardboard dry-erase melamine boards. Easy to wipe clean for repeated use. Durable frameless hardboard material. Great for practicing penmanship, math facts, or games in the school. Also great for visual displays, signage, or quick notes in the office or commercial setting.

ID No.	W x H	Shpg. Wt.	Unit	Price
<b>Penmanship Ruled</b> —Front side features penmanship-practice ruling, back side is unruled.				
5 UNV-43911	11¾" x 8¾"	4 lbs.	Pack	28-46
<b>Unruled</b> —Front and back sides are unruled.				
6 UNV-43910	11¾" x 8¾"	4 lbs.	Pack	23-89

D



E



## D MAGNETIC CUBICLE KEEPERS®

Attach phone lists, photos, certificates and more to file cabinets, desks or any metal surface. Use horizontally or vertically. Polypropylene insertable holder with black, magnetic backing. For 8½" x 11" documents.

ID No.	Color	W x H	Qty.	Unit	Price
7 CLI-37991	Clear	9¼" x 11¼"	25	Box	83-36

## E CUBICLE KEEPERS®

Repositionable, Velcro®-Brand fasteners grip office panel walls to display lists, photos, certificates. Use horizontally or vertically. Polypropylene. For 8½" x 11" documents.

ID No.	Color	W x H	Qty.	Unit	Price
8 CLI-38991	Clear	9¼" x 11¼"	25	Box	74-13

Prices subject to change without notice.

Visit our website for the latest pricing and product information.

# Office Furnishings Boards/Cubicle/Personal



universal.

## A LAP/LEARNING DRY-ERASE BOARD

Convenient lap boards for school, customer displays, or quick visual communication. Double-sided hardboard dry-erase melamine boards. Easy to wipe clean for repeated use. Durable frameless hardboard material. Great for practicing penmanship, math facts, or games in the school. Also great for visual displays, signage, or quick notes in the office or commercial setting.

ID No.	W x H	Shpg. Wt.	Qty.	Unit	Price
<b>Penmanship Ruled</b> —Front side features penmanship-practice ruling, back side is unruled.					
1	UNV-43911	11¾" x 8¾"	4 lbs.	6 Pack	28.46
<b>Unruled</b> —Front and back sides are unruled.					
2	UNV-43910	11¾" x 8¾"	4 lbs.	6 Pack	23.89



## B SELF-STICK DRY ERASE SHEETS

Turn any surface into a dry-erase board. Peel off backing and apply to clean surfaces including walls, chalkboards, etc. Create custom calendars, charts and more. Removable and repositionable.

ID No.	W x H	Color	Qty.	Unit	Price
3	CLI-57724	17" x 24"	15	Box	71.62
<b>Laser &amp; Inkjet Compatible</b> —Download free templates at the C-Line® website.					
4	CLI-57911	8½" x 11"	25	Box	37.28

## C MAGNETIC CUBICLE KEEPERS®

Attach phone lists, photos, certificates and more to file cabinets, desks or any metal surface. Use horizontally or vertically. Polypropylene insertable holder with black, magnetic backing.

ID No.	Color	W x H	Qty.	Unit	Price
5	CLI-37991	Clear	9¼" x 11¼"	25 Box	83.36

## D CUBICLE KEEPERS®

Repositionable, Velcro®-backed fasteners grip office panel walls to display lists, photos, certificates.

ID No.	Color	W x H	Qty.	Unit	Price
6	CLI-38991	Clear	9¼" x 11¼"	25 Box	74.13

MasterVision®

## E KAMASHI WET-ERASE BOARD

Black wet erase board features a magnetic surface that accepts chalk based wet erase markers for intense color contrast that resists smudging. It's perfect for magnetically posting messages as well as making hand-written notes. The beveled frame has a black linen texture and can be mounted vertically or horizontally. Hanging hardware included.

ID No.	W x H	Frame Color	Shpg. Wt.	Unit	Price
7	BVC-MM07151620 *	36" x 24"	Black	11 lbs.	Each 76.46
8	BVC-MM14151620 *	48" x 36"	Black	20 lbs.	Each 190.16

\* ISO 9001-2008.



## F GLO-WRITE® FLUORESCENT MARKER FIVE-COLOR SET

For glowing presentations every time, these wet-erase fluorescent markers can make any meeting more memorable. Comes in five fun Glo-Write® colors - ink wipes off quickly with damp cloth. ✓

ID No.	Color	Tip	Qty. per Unit	Unit	Price
9	QRT-5090 *	Assorted	Bullet	5 Set	32.70

\* ACMI AP Non-Toxic Certified. Fluorescent Blue; Fluorescent Green; Fluorescent Pink; White; Fluorescent Yellow.

## G NEON DRY ERASE MARKER SET

Make your messages stand out with neon markers. Premium dry-erase markers in bold fluorescent colors for use on dark surfaces. Bullet tip draws thick lines that are noticeable and easy to read. ✓

ID No.	Color	Tip	Qty. per Unit	Unit	Price
10	QRT-79551 *	Assorted	Bullet	4 Pack	11.56

\* ACMI AP Non-Toxic Certified. Neon Blue; Neon Green; Neon Pink; Neon Yellow.

## H CORK BULLETIN BORDER

Durable, natural cork bulletin border with oak frame creates a tackable display surface for securing documents, presentations and displays with push pins. Self-healing surface.

ID No.	W x H	Frame Color	Shpg. Wt.	Unit	Price
11	QRT-300B	48" x 5"	Oak	5 lbs.	Each 63.99

## I BULLETIN BAR II®

Durable natural-cork bulletin bar with plastic frame creates tackable display surface for securing documents, presentations and displays with push pins. Delivers effective performance in robust display environments. Self-healing surface. Includes easy-to-mount hardware and push pins.

ID No.	W x H	Frame Color	Shpg. Wt.	Unit	Price
12	QRT-23401	12" x 1"	Black	1 lb.	Each 13.33
13	QRT-23501	18" x 1½"	Black	1 lb.	Each 18.58
14	QRT-23502	18" x 1½"	Putty	1 lb.	Each 14.58

universal.

## J CORK BULLETIN BAR

Keep bulletins, documents, and signs on-display with these convenient cork bars. Natural self-healing cork bulletin bar with aluminum frame is designed for longevity. Great for heavy-use environments. Connect multiple bars together for virtually any length or configuration. Easy-to-install with mounting tape or magnets. Includes pushpins, mounting tape and magnets.

ID No.	W x H	Frame Color	Shpg. Wt.	Unit	Price
15	UNV-43418	18" x 1"	Silver	1 lb.	Each 15.34
16	UNV-43424	24" x 1"	Silver	1 lb.	Each 18.79
17	UNV-43436	36" x 1"	Silver	1 lb.	Each 22.26
18	UNV-43448	48" x 1"	Silver	1 lb.	Each 26.23

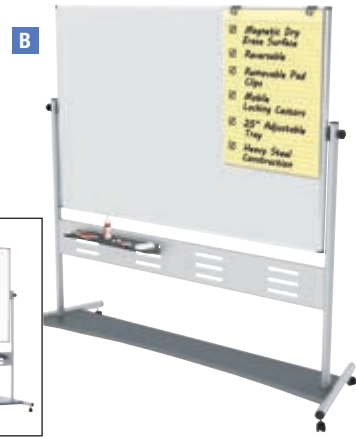

## MasterVision®

### A CREATION STATION DRY ERASE BOARD

Fully mobile and adjustable double sided easel is versatile enough for any situation. Having adjustable height, this product is usable by any age group. Contains four 2" easy glide casters for enhanced mobility which are lockable when not in use.

ID No.	W x H	Frame Color	Shpg. Wt.	Unit	Price
<b>Melamine Surface</b>					
1	BVC-EA49125016 *	29½" x 74¾"	Black	41 lbs.	Each 406-29
<b>Lacquered Steel Surface</b>					
2	BVC-EA49145016 *	29½" x 74¾"	Black	46 lbs.	Each 446-83

\* ISO 9001-2008.

### B REVOLVER EASEL

Revolving double-sided dry erase mobile presentation easel is heavy-duty and reversible. It features a Magnetic Gold Ultra™ lacquered steel surface on both sides. Extra-large repositionable steel pen tray can be positioned in several places. Tubular steel frame, support bars and easy glide locking casters make this one of the most stable large mobile easels in the marketplace. 📦 🔄 ♻️

ID No.	W x H	Frame Color	Shpg. Wt.	Unit	Price
<b>Maximum Easel Height 80"</b> —No-pinch pad retainer holds easels of any size.					
3	BVC-QR5203	35¾" x 47¼"	Silver	50 lbs.	Each 833-02
<b>Maximum Easel Height 80"</b> —Plastic pad hooks are removable, easily adjustable.					
4	BVC-QR5507 *	70¼" x 47¼"	Silver	96 lbs.	Each 1,041-52

\* BVC-QR5507—ISO 9001-2000.

### C EARTH SILVER EASY CLEAN MOBILE REVOLVER DRY ERASE BOARDS

Durable and versatile dry erase boards are perfect for classrooms and all training environments. Silver Easy Clean surface resists ghosting. Dual surfaces revolve easily, providing you with additional writing space. Portable with easy glide locking casters for full mobility. Includes aluminum pen tray. 📦 🔄 ♻️

ID No.	W x H	Frame Color	Shpg. Wt.	Unit	Price
5	BVC-RQR0221 *	36" x 48"	Silver	35 lbs.	Each 754-64
6	BVC-RQR0521 *	48" x 70"	Silver	55 lbs.	Each 1,119-95

\* ISO 9001-2008. Contains 45% post-consumer recycled content, 60% total recycled content.



### D PRESENTATION FLIPCHART EASEL WITH DRY ERASE SURFACE

Dual sided easel features a dry-erase writing surface and a place where 27" x 34" pads (sold separately) can be securely mounted to both sides of the board. Scratch- and dent-resistant, blow-molded, high-density polyethylene construction with A-frame design provides a sturdy writing base. Includes built-in marker holder, marker tray and inside storage shelf. Handles and four locking casters for easy transport and set-up. Maximum easel height: 73". Manufacturer's limited fifteen-year warranty. 📦 🔄 ♻️

ID No.	Board W x H	Frame Color	Shpg. Wt.	Unit	Price
<b>Presentation Flipchart Easel with Dry Erase Surface on One Side</b> —27" x 34" dry erase surface on one side.					
7	ICE-30237 *	33" x 28"	Charcoal	54 lbs.	Each 513-95

\* Contains 35% total recycled content.

### E PORTABLE FLIPCHART EASEL

Ultra-sturdy, ultra-smart design for easy setup and transport. Constructed of blow-molded, high-density, dent- and scratch-resistant polyethylene. Molded-in grab handles and steel legs fold and lock in back cavity for better portability. Pads securely mount to board with thumb screws. Maximum easel height: 73". Manufacturer's limited five-year warranty. 📦 🔄 ♻️

ID No.	Board W x H	Frame Color	Shpg. Wt.	Unit	Price
<b>Portable Flipchart Easel with Dry Erase Surface</b> —Has 27" x 34" dry erase surface on one side.					
8	ICE-30227 *	35" x 30"	Charcoal	29 lbs.	Each 427-95

\* Contains 35% total recycled content.



**Fast Delivery**

In most cases, the next business day!



## PLUS

### A MOBILE PARTITION BOARD

Write on movable partition. Create your own meeting space in any open area and have the convenience of a double-sided magnetic surfaced dry-erase board. Includes stand, markers and eraser ✕

ID No.	W × H	Frame Color	Shpg. Wt.	Unit	Price
1 PLS-912MPBLG	38¾" × 70¾"	Light Gray	33 lbs.	Each	564.00
2 PLS-912MPBNB	38¾" × 70¾"	Navy Blue	33 lbs.	Each	564.00

## MasterVision®

### B PLATINUM MOBILE EASEL

Features a contemporary design with a magnetic porcelain Platinum Pure White™ surface for extensive use. Fully adjustable with five easy-glide casters for full mobility (casters are lockable when not in use). The versatile no-pinch pad retainer with adjustable easel pad hooks allows you to use any size easel pad. It also features two magnetic extension bars that allow you to present up to three sheets of paper at one time and a full length pen tray. ✕

ID No.	Board W × H	Frame Color	Shpg. Wt.	Unit	Price
<b>Maximum Height 73"</b>					
3 BVC-EA48066720 ★	29" × 41"	Black	28 lbs.	Each	603.89
★ ISO 9001-2008.					



### C EURO™ MAGNETIC PRESENTATION EASEL

Collapsible easel with smooth magnetic whiteboard for streamlined presentations. Delivers effective performance in occasional-use environments. Holds standard flipcharts. Sturdy tripod construction with extendable arms displays three sheets simultaneously. Euro™ design. Includes built-in marker clip and tray. Manufacturer's ten-year warranty.

ID No.	Board W × H	Frame Color	Shpg. Wt.	Unit	Price
4 QRT-EU500E	27" × 39"	Silver	32 lbs.	Each	404.86

## MasterVision®

### D TRIPOD EXTENSION BAR MAGNETIC GOLD ULTRA DRY ERASE EASEL

Choose the perfect height for your needs. Use as a tabletop or floor-standing unit. Steel magnetic dry erase surface stands up to frequent use. Adjustable clips accommodate any size easel pad while two magnetic extension bars allow you to present up to three sheets of paper at a time. Folds flat for easy storage. Pen tray for writing instruments.

ID No.	Color	Shpg. Wt.	Unit	Price
5 BVC-EA23066720 ★	Black/Silver	26 lbs.	Each	370.26
★ ISO-9001-2008.				



### E MAGNETIC DRY ERASE EASEL

Basic, 70" tripod presentation easel includes a 27" × 35" magnetic whiteboard writing surface and flipchart holder. Whiteboard also functions as magnetic bulletin board. Best for light use. Graphite frame features locking legs. Sturdy tripod construction with extendable arms displays three sheets simultaneously. Collapsible for storage and transport. Includes accessory tray and one Quartet® dry-erase marker. Manufacturer's limited ten-year warranty.

ID No.	Board W × H	Frame Color	Shpg. Wt.	Unit	Price
6 QRT-67E	27" × 35"	Graphite	26 lbs.	Each	287.85





VISIT US ONLINE FOR OUR FULL ASSORTMENT OF  
**Boards & Supplies**



## PLUS

### A MOBILE PARTITION BOARD

Write on movable partition. Create your own meeting space in any open area and have the convenience of a double-sided magnetic surfaced dry-erase board. Includes stand, markers and eraser.

ID No.	W x H	Frame Color	Shpg. Wt.	Unit	Price
1 PLS-912MPBLG	38 3/4" x 70 1/2"	Light Gray	33 lbs.	Each	564.00
2 PLS-912MPBNB	38 3/4" x 70 1/2"	Navy Blue	33 lbs.	Each	564.00

## quartet.

### B MOTION DUAL-TRACK MOBILE MAGNETIC DRY-ERASE EASEL

Dual-track design allows for easy maneuvering between boards and precise positioning that keeps important notes at eye level. The innovative, dual-track with sliding whiteboard panels provides double the dry-erase surface in a compact space. Manufacturer's limited 10-year warranty.

ID No.	Board W x H	Frame Color	Shpg. Wt.	Unit	Price
3 QRT-ECM4068DT	40 1/2" x 34"	White	54 lbs.	Each	771.15

### C TOTAL ERASE® REVERSIBLE MOBILE PRESENTATION EASEL

Reversible mobile easel with double-sided, highly durable Total Erase® whiteboard surfaces that resist staining, ghosting, scratching and denting. Delivers quality performance in frequent-use environments. Subtle grid pattern. The easel comes equipped with flipchart holders and wheels for easy to transport. Neutral-color frame. Includes accessory tray and one Quartet® dry-erase marker.

ID No.	W x H	Frame Color	Shpg. Wt.	Unit	Price
<b>Large Easel</b> —75" high overall.					
4 QRT-3640TE	72" x 48"	Neutral/Beige	101 lbs.	Each	1,085.78

### D PRESTIGE® 2 MOBILE PRESENTATION EASEL

Mobile presentation easel has a large magnetic Total Erase® whiteboard surface that doubles as a magnetic bulletin board, and includes a flipchart holder. The magnetic Total Erase® whiteboard is very durable and resists ghosting and staining. A light grid pattern is printed on the board to keep handwriting aligned, but is only visible up close. The included flipchart holders keep any standard size flipchart in place. Manufacturer's limited 15-year warranty.

ID No.	Color	Shpg. Wt.	Unit	Price	
5 QRT-ECM64P2	Graphite	66 lbs.	Each	1,084.44	
<b>Extendable Arms</b> —Display three sheets simultaneously.					
6 QRT-ECM32P2	Graphite	35 lbs.	Each	462.62	



**SAFCO**

### E IMPROMPTU® WHITEBOARD COLLABORATION SCREEN

Easily define any space with this magnetic whiteboard screen. Features steel frame with four casters (two locking) for easy mobility. Magnetic accessory tray, eraser and easel pad hooks included.

No.	W x D x H	Color	Shpg. Wt.	Unit	Price
7 SAF-8511BL	42" x 21.5" x 72"	Black/White	60 lbs.	Each	589.00
8 SAF-8511GR	42" x 21.5" x 72"	Gray/White	60 lbs.	Each	589.00

\* GREENGUARD Certified.

## MasterVision®

### F SILVER EASY CLEAN DRY ERASE MOBILE PRESENTATION EASEL

Suitable for everyday use! Patented no-pinch pad retainer with adjustable pad hooks accommodates any size easel pads. Tilting surface provides maximum comfort and the perfect viewing level. Easy glide locking casters for full mobility.

ID No.	Color	Shpg. Wt.	Unit	Price
9 BVC-EA4800055	Black	28 lbs.	Each	291.76

\* ISO:9001-2008.

### G PLATINUM MOBILE EASEL

Features a contemporary design with a magnetic porcelain Platinum Pure White™ surface for extensive use. Fully adjustable with five easy-glide casters for full mobility (casters are lockable when not in use). The versatile no-pinch pad retainer with adjustable easel pad hooks allows you to use any size easel pad. It also features two magnetic extension bars that allow you to present up to three sheets of paper at one time and a full length pen tray.

ID No.	Board W x H	Frame Color	Shpg. Wt.	Unit	Price
<b>MAXIMUM HEIGHT 73"</b>					
10 BVC-EA48066720	29" x 41"	Black	28 lbs.	Each	603.89

\* ISO 9001-2008.

Prices subject to change without notice.  
Visit our website for the latest pricing and product information.

# Office Furnishings Boards/Easel, Presentation



## universal.

### A FOLDABLE DOUBLE-SIDED DRY ERASE EASEL

Double-sided, melamine dry-erase board features no-pinch retainers with adjustable pad hooks to accommodate any size easel pad. Tubular-metal easel frame enables two configurations: presentation board and tabletop worksurface. Folds flat for storage. Tabletop worksurface configuration height: 42". Presentation-board configuration height: 67". Manufacturer's limited one-year warranty.

ID No.	Board W × H	Frame Color	Shpg. Wt.	Unit	Price
1 UNV-43030 ★	29" × 41"	Black	33 lbs.	Each	259.94

★ ISO 9001-2008.

### B DRY ERASE EASEL

Easy-to-clean dry-erase board with a useful no-pinch pad retainer. Overall height is adjustable, allowing you to use it as a tabletop or floor stand. Four-leg design provides additional stability. Manufacturer's limited one-year warranty.

ID No.	Board Size	Easel Height	Easel Color	Shpg. Wt.	Unit	Price
2 UNV-43033 ★	29" × 41"	42" - 67"	Silver/White	20 lbs.	Each	299.49

★ ISO 9001-2008.

### C TRIPOD DRY ERASE EASEL

Easy-to-clean melamine board features a convenient tripod design and fully adjustable pad retainer. Sturdy and stylish, you can place it just about anywhere. Great for hotels, schools, libraries, hospitals, executive offices, conference rooms, board rooms and more. Manufacturer's limited one-year warranty.

ID No.	Board Size	Easel Height	Easel Color	Shpg. Wt.	Unit	Price
3 UNV-43032 ★	29" × 41"	44" - 78"	Black/White	23 lbs.	Each	243.44
4 UNV-43031 ★	29" × 41"	44" - 78"	Silver/White	23 lbs.	Each	446.28

★ ISO 9001-2008.

## quartet.

### D DURAMAX® PORTABLE PRESENTATION EASEL

72" high easel collapses down to just 39" high for storage. Holds flipchart pad or reversible dry erase board (sold separately). Plastic. Spring-loaded pad retainer, molded handgrips, large accessory compartment. 28" wide. Manufacturer's lifetime warranty.

ID No.	Color	Shpg. Wt.	Unit	Price
5 QRT-200E	Gray	27 lbs.	Each	564.56

### E LIGHTWEIGHT TELESCOPING ALUMINUM TRIPOD EASEL

Features ¾" tubular telescoping legs that adjust in height. Solid construction of the locking cross-base reinforces the tripod design for added stability. Adjustable board holders support boards up to 48" × 36" and 25 lbs. Easel bag sold separately.

ID No.	Color	Shpg. Wt.	Unit	Price
6 QRT-51E	Black	4 lbs.	Each	103.49
7 QRT-50E	Silver	4 lbs.	Each	103.27

### F HEAVY-DUTY INSTANT™ EASEL

Compact instant easel folds to travel in a briefcase and sets up in seconds. Stands 63" high, folds to 25". Adjustable display holder; antiskid feet. Lightweight steel. Supports boards and placards up to 10 lbs. Manufacturer's one-year warranty.

ID No.	Color	Shpg. Wt.	Unit	Price
8 QRT-27E	Black	5 lbs.	Each	55.06



### G SELF-STICK EASEL PADS

Features premium paper that resists marker bleed-through; they stick to most surfaces and can be repositioned again and again, without surface damage. The sturdy backcard features a handle for easy portability and universal slots to fit most easel stands.

ID No.	Size	Ruling	Paper Color	Sheets/Pad	Qty.	Unit	Price
9 MMM-559	25 × 30	Unruled	White	30	2	Carton	92.25



## A BRONZE FINISH TRIPOD EASEL

Strong and lightweight, this steel tripod can display signage or images securely. Locking mechanism to ensure legs are secure. Tripod base folds up quickly for easy storage. Manufacturer's one-year warranty.

ID No.	Color	Shpg. Wt.	Unit	Price
1 QRT-21E	Bronze	12 lbs.	Each	179.75



## B TELESCOPING TRIPOD DISPLAY EASEL

Telescoping metal legs adapt to floor or tabletop use while adjustable support brackets display materials at exactly the height you need. No-pinch pad retainer for fast and easy attachment; hooks slide to fit any type of easel pad.

ID No.	Color	Shpg. Wt.	Unit	Price
2 BVC-FLX09101MV	Black	3 lbs.	Each	93.74

**Lightweight**—Adjusts from 35" to 64" high and supports up to 25 lbs.

## C QUANTUM HEAVY DUTY DISPLAY EASEL

The tripod display easel is designed to be lightweight yet extremely sturdy. Handy easel adjusts easily from 35.43" to 63" to display items of different sizes. Holds up to 25 lbs. and features fixed supports for additional strength.

ID No.	Color	Shpg. Wt.	Unit	Price
3 BVC-FLX11404 *	Black	4 lbs.	Each	79.29

\* ISO:9001-2008.



## D HEAVY-DUTY ADJUSTABLE PRESENTATION BOARD

Excellent solution for public notice needs. Strong, sturdy tripod design supports up to 45 lbs. of material. Features adjustable chart holders. Rubber anti-skid feet. Tubular metal construction with center brace. Includes a full length adjustable no-pinch pad retainer. For tabletop or floor. Maximum height of 69". Manufacturer's limited one-year warranty.

ID No.	Color	Shpg. Wt.	Unit	Price
4 UNV-43034 *	Black	4 lbs.	Each	186.24
5 UNV-43035 *	Silver	4 lbs.	Each	186.24

\* ISO 9001-2008.



## E LIGHTWEIGHT TELESCOPING 3-LEG EASEL

Lightweight easel with adjustable aluminum tubular twist-lock legs. Fully adjustable height—use as floor or tabletop display. No-pinch pad retainer for effortless one-handed operation. Use with or without pad holder. Holds a full easel pad. Downsizes for storage and transport. Supports up to 25 lbs. of display materials. Locking cross-braces. Antiskid feet. Manufacturer's limited one-year warranty.

ID No.	Color	Shpg. Wt.	Unit	Price
6 UNV-43150 *	Black	3 lbs.	Each	89.32
7 UNV-43050 *	Silver	3 lbs.	Each	87.62

\* ISO 9001-2008.

## F INSTANT SETUP FOLDAWAY EASEL

Trim, lightweight steel easel sets up in seconds. Collapsible and portable, it's ideal for travel. Adjustable display holders securely grip and display graphs, posters and lightweight boards. Anti-skid feet. Manufacturer's limited one-year warranty.

ID No.	Color	Shpg. Wt.	Unit	Price
8 UNV-43027 *	Black	5 lbs.	Each	47.99
9 UNV-43029 *	Black	3 lbs.	Each	44.74

\* ISO 9001-2008.

## G PORTABLE TABLETOP EASEL

Strong steel construction—supports up to 5 lbs. Sets up in seconds. Sturdy, easy-to-adjust chart supports. Compact tabletop unit that's easy to store and transport. Manufacturer's limited one-year warranty.

ID No.	Color	Shpg. Wt.	Unit	Price
10 UNV-43028 *	Black	1 lb.	Each	18.91

\* ISO 9001-2008.



## H DISPLAY EASEL CARRYING CASE

Ideal for Quartet® easels and flipchart pad retainers, this water- and stain-resistant nylon carrying case features a heavy-duty zipper, reinforced carrying handle and shoulder strap.

ID No.	W × D × H	Material	Color	Unit	Price
11 QRT-156355	38½" × 1½" × 6½"	Nylon	Black	Each	74.27

Prices subject to change without notice.  
Visit our website for the latest pricing and product information.

# Office Furnishings Boards/Easel & Message



## MasterVision®

### A INSTANT EASEL

Convenient instant easel is easily portable, lightweight and instantly collapsible. Easy to set up, and fold conveniently for storage and transport. Easel collapses easily to fit into a briefcase or carry bag.

ID No.	Color	Shpg. Wt.	Unit	Price
<b>Lightweight</b>				
1	BVC-FLX04201MV *	Black	3 lbs.	Each 34.29
<b>Heavy-Duty</b>				
2	BVC-FLX10201MV *	Black	5 lbs.	Each 45.78

\* ISO Compliant.

## MasterVision®

### F WET ERASE BOARD

Reversible sign board offers a versatile, simple and efficient solution for displaying information that needs daily or constant updates. The black, magnetic, double-sided wet erase surface is the perfect background for opaque wet erase markers that don't smudge when touched. The long lasting varnished black or cherry wood frame offers a high end look. Ideal for restaurants, coffee-shops or spas, this sign helps create a relaxed environment, while being very effective at conveying simple and direct messages. ☒

ID No.	W x H	Frame Color	Shpg. Wt.	Unit	Price
<b>Double-Sided Black Magnetic Surface—Stands 45" tall.</b>					
8	BVC-DKT30505042 *	21" x 33"	Black	20 lbs.	Each 312.24
9	BVC-DKT30505052 *	21" x 33"	Cherry	20 lbs.	Each 312.24
<b>Double-sided Black Wet Erase Board and Poster Holder—Aluminum frame with vinyl cover is 42" tall.</b>					
10	BVC-DKT30505072 *	23" x 33"	Silver	20 lbs.	Each 357.86

\* ISO 9001-2008.

## quartet.

### B INSTANT EASEL

Folds down and sets up in seconds. Adjustable display holder; antiskid feet. Lightweight steel. Supports boards up to 5 lbs. Manufacturer's one-year warranty.

ID No.	Color	Shpg. Wt.	Unit	Price
<b>Full Size—62¾" high, folds to 15" high.</b>				
3	QRT-29E	Black	3 lbs.	Each 40.44
<b>Tabletop Size—14¾" high.</b>				
4	QRT-28E	Black	1 lb.	Each 22.51

### C TRIPOD WOOD FLOOR EASEL

Lightweight wood easel stands 64" high, folds to 3" x 3" x 35¼". Light enough to carry from room to room; disassembles for storage. The sturdy tripod base with support ledge holds boards up to 36" x 24".

ID No.	Color	Shpg. Wt.	Unit	Price
5	QRT-41E	Natural Wood	5 lbs.	Each 69.24

### D ADJUSTABLE SIGN STAND

Freestanding pedestal sign holder with adjustable telescoping tube and bottom ledge holds 11" to 40" signs. Ideal for high-traffic environments. Easily secure two same-sized posters for dual-sided display, and ensure your message is visible in all directions so that you might reach a larger audience.

ID No.	Color	Overall Height	Insert W x H	Material	Unit	Price
6	QRT-7923	Silver 44" - 73"	8½ x 11 - 40	Metal	Each	279.54

### E CLIP-FRAME PEDESTAL SIGN

Durable pedestal holds 18" x 24" Improv™ Signs to give maximum visibility to your customized, high-quality display. Ideal for high-traffic environments.

ID No.	Color	Overall Height	Insert W x H	Material	Unit	Price
7	QRT-LCF2418	Silver 54"	24 x 18	Aluminum	Each	304.77

## deflecto®

### G TELESCOPING SIGN DISPLAY

Versatile telescoping floor sign holder adjusts in height and orientation so you have just the display you need. Top sign panel angles and rotates to accommodate printed sheets either vertically or horizontally. Easily adjust height as needed. Clear, magnetic front panel is removable, making sign changes quick and easy. Black inlaid panel tastefully frames your message. Great for trade shows, lobby areas as well as general directional signage. Heavy-duty steel base. Light assembly required. ☒

ID No.	Color	Material	Insert W x H	Unit	Price
11	DEF-790804	Black Steel	8½ x 11	Each	233.05
12	DEF-790704	Black Steel	11 x 17	Each	275.79

## quartet.

### H ADJUSTABLE SINGLE-PEDESTAL MAGNETIC LETTER BOARD

Durable magnetic letter board with adjustable pedestal for maximum display visibility in high-traffic environments. Weighted single pedestal base adjusts from 45" to 62". Magnetic white plastic letters sold separately. Chrome-finish radius frame. ☒

ID No.	Board W x H	Frame Color	Shpg. Wt.	Unit	Price
13	QRT-7921M	24" x 18"	Gray	22 lbs.	Each 348.55





## quartet.

### A SIGN(WARE)™ PEDESTAL SIGN

Lightweight, portable pedestal with sturdy base lets you choose from 12 assorted pre-printed signs and includes a blank panel for customized messages. Accommodates any 14" x 11" poster-size insert and accommodates dual-sided displays. Standing over 4-feet tall, the Sign(ware)™ Pedestal Sign is ideal for high-traffic environments.

ID No.	Color	Overall Height	Insert W x H	Material	Unit	Price
1 QRT-3655	★ Black	52"	14 x 11	Plastic/Metal	Each	240.72

★ Printed signs: No Smoking, Smoking In Designated Areas Only, Meeting In Progress, Welcome — Please Register, Caution Wet Floor, Smoking Permitted In This Area Only, Please Watch Your Step, Authorized Personnel Only, Please Order Here, Section Closed, Please Seat Yourself & Please Wait to be Seated. Printed signs: No Smoking, Smoking In Designated Areas Only, Meeting In Progress, Welcome — Please Register, Caution Wet Floor, Smoking Permitted In This Area Only, Please Watch Your Step, Authorized Personnel Only, Please Order Here, Section Closed, Please Seat Yourself & Please Wait to be Seated.

### B DESIGNER SIGN STAND

Standing nearly 5-feet tall, this durable 11" x 17" aluminum frame instantly turns signs, literature, fliers and printouts into customized displays. Ideal for high-traffic environments. Dual-function display panel rotates vertically or horizontally. Frame fits both 8½" x 11" and 11" x 17" inserts.

ID No.	Color	Overall Height	Insert W x H	Material	Unit	Price
2 QRT-7922	Silver	59"	8½ x 11; 11 x 17	Aluminum	Each	373.63



## DURABLE

THE STYLE OF SUCCESS

### C INFO SIGN DUO FLOOR STAND

Patented mechanism allows effortless rotation from portrait to landscape orientation. Anti-glare, crystal clear front panel removes in seconds for quick insertion of sheets. High-quality aluminum floor stand has a rugged cast iron base with rubber pads for stability. Can also be used with DURABLE Literature Dispensers (sold separately). ✖

ID No.	Color	Overall Height	Insert W x H	Material	Unit	Price
3 DBL-481523	Clear	43" - 50"	11 x 17	Aluminum/Acrylic/ Cast Iron Base	Each	355.95
4 DBL-481423	Clear	40½" - 46½"	8½ x 11	Aluminum/Acrylic/ Cast Iron Base	Each	276.45

### D SHERPA® INFOBASE SIGN STAND

Takes your message from the printer to the public in a snap! Telescopic floor sign stand for 8½" x 11" inserts. Removable hard acrylic panel is open on three sides for easy loading. Tilt-adjustable panel can be viewed from either side. 40-60" height-adjustable pole posts sign at desired level. Stable round base.

ID No.	Color	Overall Height	Insert W x H	Material	Unit	Price
5 DBL-558957	Gray	Adjustable 40-60"	8½ x 11	Acrylic/Metal	Each	162.95

## quartet.

### E IMPROV™ A-FRAME SIGN WITH TOTAL ERASE® SURFACE

Total Erase® whiteboard panels on each side resist ghosting and staining. Paper signs up to 2 ft x 3 ft can also be inserted. Frosted plastic overlay protects signage for indoor and outdoor use. Silver aluminum frame is durable and with non-skid feet and folds for storage.

ID No.	Color	Overall Height	Insert W x H	Material	Unit	Price
6 QRT-AF32	Silver	42"	24 x 36	Aluminum	Each	434.08

## MasterVision®

### F FLOOR STAND SIGN HOLDER

Extremely versatile, sign holders offer a simple and efficient solution for displaying information that needs to be regularly updated. Steel support leg easily adjusts to a height that's perfect for your needs. Magnetic dry erase surface allows you to make updates quickly and easily. Weighted base keeps the sign in place. Includes dry-erase-arrow sign, stand and base. ✖

ID No.	W x H	Frame Color	Shpg. Wt.	Unit	Price
<b>Arrow</b> —Maximum height 63".					
7	BVC-SIG01010101 ★ 25" x 17"	Black	16 lbs.	Each	135.34
<b>Rectangle</b> —Maximum height 68".					
8	BVC-SIG07060101 ★ 15" x 11"	Black	12 lbs.	Each	135.34

★ ISO 9001-2008.

Prices subject to change without notice.  
Visit our website for the latest pricing and product information.

# Office Furnishings Boards/Message

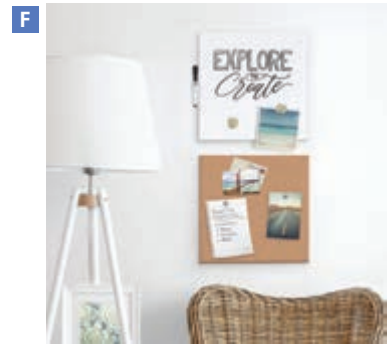

## A ENCLOSED INDOOR FABRIC BULLETIN BOARD WITH HINGED DOORS

Highly durable, enclosed fabric bulletin board backed by high-density fiberboard secures documents with push pins. Locking shatterproof acrylic doors display and protect information. Perfect for employee lounges and other high-traffic areas. Self-healing surface. Manufacturer's 20-year warranty.

ID No.	Description	W x H	Frame Color	Shpg. Wt.	Unit	Price
<b>One Door</b>						
1	QRT-2363L	One Door	24" x 36"	Graphite	23 lbs. Each	563.10
<b>Two Doors</b>						
2	QRT-2364L	Two Doors	48" x 36"	Graphite	36 lbs. Each	934.77
<b>Three Doors</b>						
3	QRT-2367L	Three Doors	72" x 48"	Graphite	58 lbs. Each	1,695.85

## B ENCLOSED INDOOR CORK & FABRIC BULLETIN BOARD WITH SLIDING GLASS DOORS

Highly durable, enclosed fabric bulletin board backed by high-density fiberboard secures documents with push pins. Locking, sliding glass doors display and protect important information in employee lounges and other high-traffic areas. Self-healing surface. Manufacturer's 20-year warranty.

ID No.	Description	W x H	Frame Color	Shpg. Wt.	Unit	Price
<b>Two Doors</b>						
4	QRT-2364S	Two Doors	48" x 36"	Graphite Gray	43 lbs. Each	988.36

## C ENCLOSED INDOOR CORK BULLETIN BOARD WITH HINGED DOORS

Enclosed bulletin board is ideal for indoor use. Acrylic glass doors are shatterproof and lockable. Post notes, photos and more to the cork surface using push pins or thumbtacks. Stylish frame fits any décor. One key per lock included. Manufacturer's twenty-year warranty.

ID No.	Description	W x H	Frame Color	Shpg. Wt.	Unit	Price
<b>One Door</b>						
5	QRT-363	One Door	24" x 36"	Oak	18 lbs. Each	478.92
6	QRT-2363	One Door	24" x 36"	Silver	17 lbs. Each	524.14
<b>Two Doors</b>						
7	QRT-364	Two Doors	48" x 36"	Oak	33 lbs. Each	797.96
8	QRT-2364	Two Doors	48" x 36"	Silver	31 lbs. Each	841.95
<b>Three Doors</b>						
9	QRT-2366	Three Doors	72" x 36"	Silver	45 lbs. Each	1,236.80
10	QRT-2367	Three Doors	72" x 48"	Silver	55 lbs. Each	1,500.50

## D ENCLOSED OUTDOORS BULLETIN BOARD

Highly durable, enclosed natural-cork bulletin board backed by high-density fiberboard secures documents with push pins. Locking, water-resistant, shatterproof door displays and protects information in any outdoor environment. Self-healing surface. Manufacturer's 20-year warranty.

ID No.	Description	W x H	Frame Color	Shpg. Wt.	Unit	Price
<b>Two Doors</b>						
11	QRT-2124	Two Doors	48" x 36"	Silver	38 lbs. Each	946.11

## E ENCLOSED MAGNETIC DIRECTORY

Display directories, schedules or information on this indoor magnetic directory. Set up and change postings easily on the black surface with magnetic letters (sold separately). Horizontal ridges keep letters straight. Features shatterproof acrylic windows and locking doors. Radius-edge aluminum frame.

ID No.	Description	W x H	Frame Color	Shpg. Wt.	Unit	Price
<b>One Door</b>						
12	QRT-2963LM	One Door	24" x 36"	Graphite	28 lbs. Each	698.00
13	QRT-2964LM	One Door	48" x 36"	Graphite	43 lbs. Each	1,069.75



U BRANDS

## F TILE BOARD VALUE PACK



Perfect and functional solution to communicate messages with dry erase markers in your office, school classroom, home, college dorm room, coffee shop, restaurant or any commercial space. Using the U Brands dry erase marker provides the ultimate, mess-free writing and eras-ability experience. Magnetic writing surface functions as a bulletin board as well; simply use any board magnets to pin all your notes, messages, pictures, memos, calendars, menus, reminders and more. U Brands dry erase boards are designed from the ground up with U in mind! Mounting Hardware; Instructions. Manufacturer's limited three-year warranty.

ID No.	W x H	Color	Shpg. Wt.	Qty.	Unit	Price
<b>Undated One Month Calendar</b>						
14	UBR-3888U0001	14" x 14"	White/Natural	1 lb.	2 Set	29.40
15	UBR-3889U0001	14" x 14"	White/Natural	1 lb.	2 Set	29.40



## 3M

### A EASY TRAP™ DUSTER SWEEP & DUST SHEETS

Trap up to 8X more dirt, dust and sand than both conventional flat fringed cotton dust mops and the professional version of a common household sweeping dust cloth brand. Has the power to trap more hair than traditional dust mops and a competitive sweeping dust cloth brand.  

ID No.	W × L	Qty.	Unit	Price
--------	-------	------	------	-------

**125-Foot Roll**—Has perforations every six inches.

1	MMM-55655W ★	5" × 125 ft	2	Carton	171.74
2	MMM-55654W ★	8" × 125 ft	1	Carton	132.95

★ Contains a minimum of 60% recycled content.

### B DOODLEDUSTER™ DISPOSABLE CLOTH

Disposable microfiber dust cloth is untreated and leaves surfaces residue-free. Ideal for dusting floors before and after polishing or prior to recoating.

ID No.	Color	No. of Sheets	Qty.	Unit	Price
--------	-------	---------------	------	------	-------

3	MMM-19152	White	250	1	Box	161.42
---	-----------	-------	-----	---	-----	--------

## boardwalk.

### C FLOOR BRUSH HEAD

Hardwood block with two threaded handle holes. Handles sold separately.

ID No.	Bristle Description	Brush Length	Unit	Price
--------	---------------------	--------------	------	-------

**Black Tampico Floor Brush Head**—For fine/medium sweep. Tampico fibers resist heat and chemicals.

4	BWK-20218	2½" Tampico Fiber	18"	Each	25.67
5	BWK-20224	2½" Tampico Fiber	24"	Each	31.27
6	BWK-20236	2½" Tampico Fiber	36"	Each	56.42

**Gray Flagged Polypropylene Floor Brush Head**—For fine sweep on smooth surfaces.

7	BWK-20424	3" Polypropylene	24"	Each	34.67
8	BWK-20436	3" Polypropylene	36"	Each	57.57

**Hardwood Block-Stiff Polypropylene Bristles**

9	BWK-20624	3" Polypropylene	24"	Each	26.68
10	BWK-20636	3" Polypropylene	36"	Each	54.14

**Palmyra Fiber Floor Brush Head**—Natural fiber for sweeping coarse/heavy debris.

11	BWK-20118	3¼" Palmyra Fiber	18"	Each	20.03
12	BWK-20124	3¼" Palmyra Fiber	24"	Each	24.85

**Stiff Polypropylene Floor Brush Head**—Maroon bristles for coarse/heavy sweep on rough surfaces.

13	BWK-20324	3¼" Stiff Polypropylene	24"	Each	27.96
14	BWK-20336	3¼" Stiff Polypropylene	36"	Each	57.76

## boardwalk.

### D METAL TIP THREADED HARDWOOD BROOM HANDLE

Die-cast aluminum threaded tip secured to natural lacquered hardwood handle.

ID No.	Size (Dia. × L)	Material	Color	Unit	Price
--------	-----------------	----------	-------	------	-------

15	BWK-136	1¾" × 60"	Wood	Natural	Each	8.36
16	BWK-138	1½" × 60"	Wood	Natural	Each	12.24

### E HEAVY-DUTY THREADED END HARDWOOD BROOM HANDLE

Natural lacquered hardwood. Standard thread.

ID No.	Size (Dia. × L)	Material	Color	Unit	Price
--------	-----------------	----------	-------	------	-------

17	BWK-137	1½" × 60"	Wood	Natural	Each	6.46
----	---------	-----------	------	---------	------	------

### F FIBERGLASS BROOM HANDLE

Super tough nylon plastic standard threaded end.

ID No.	Size (Dia. × L)	Material	Color	Unit	Price
--------	-----------------	----------	-------	------	-------

18	BWK-636	1" × 60"	Fiberglass	Black	Each	21.92
----	---------	----------	------------	-------	------	-------

**Fiberglass with nylon end.**

18	BWK-636	1" × 60"	Fiberglass	Black	Each	21.92
----	---------	----------	------------	-------	------	-------

## UNGER

Quality Tools for Smart Cleaning

### G ERGO DUST PAN WITH BROOM

Removes debris quickly without bending. Swiveling dust pan opens when base touches floor, closes when lifted. Ergonomic handle minimizes hand and arm fatigue. Broom attaches to dust pan handle.

ID No.	Color	Material	W × L	Qty.	Unit	Price
--------	-------	----------	-------	------	------	-------

19	UNG-EDPBR	Red/Silver	Metal with Vinyl Coated Handle	12" × 33"	1 each	Each	59.93
----	-----------	------------	--------------------------------	-----------	--------	------	-------

### H TELESCOPIC ERGO DUST PAN WITH BROOM

Removes debris quickly without bending. Telescopic handles adjust to fit worker height. Swiveling dust pan opens when base touches floor, closes when lifted. Ergonomic handle minimizes hand and arm fatigue. Broom attaches to dust pan handle.

ID No.	Color	Material	W × L	Qty.	Unit	Price
--------	-------	----------	-------	------	------	-------

20	UNG-EDTBG	Gray/Silver	Metal with Vinyl Coated Handle	12" × 45"	1 each	Each	70.64
----	-----------	-------------	--------------------------------	-----------	--------	------	-------

**Telescopic Handles Adjust 10" for Height Preference**—Includes SmartColor Decal Kit for color-coding.

20	UNG-EDTBG	Gray/Silver	Metal with Vinyl Coated Handle	12" × 45"	1 each	Each	70.64
----	-----------	-------------	--------------------------------	-----------	--------	------	-------

Prices subject to change without notice.

Visit our website for the latest pricing and product information.



### A ANGLED LARGE BROOM

Cut and shaped for easy sweeping; ideal for cleaning hard-to-reach areas. Flagged, long-lasting, acid-resistant polypropylene gray fill bristles. Permanent fusion set bristles won't pull out. Manufacturer's limited one-year warranty.

ID No.	Overall Length	Qty.	Unit	Price
<b>Aluminum Handle</b>				
1 RCP-6385 GRA	48 7/8"	1	Each	34.92
<b>Vinyl Coated Metal Handle</b>				
2 RCP-6375-00GY	46 7/8"	1	Each	26.50

### B ANGLED LOBBY BROOM

Great for sweeping and cleaning in restaurants, malls, lobbies, and more.

ID No.	Overall Length	Qty.	Unit	Price
3 RCP-637400BLA	35"	1	Each	13.90

## boardwalk.

### C ANGLER BROOM

Big 13" sweeping surface with sturdy flagged-tip plastic bristles. Angled cut for sweeping corners, edges and under counters. Lacquered wood handle with plastic angled shroud.

ID No.	Overall Length	Qty.	Unit	Price
4 BWK-932AEA	53"	1	Each	18.29
5 BWK-932ACT	53"	12	Count	219.48

### D WAREHOUSE BROOM

For heavy-duty sweeping. Heavy metal band with four rows of stitching for strength and durability. Lacquered wood handle.

ID No.	Overall Length	Qty.	Unit	Price
<b>Corn Fiber</b>				
6 BWK-932CEA	56"	1	Each	27.07
<b>Yucca/Corn Fibers</b>				
7 BWK-932YEA	56"	1	Each	22.04

### E CORN FIBER LOBBY/TOY BROOM

Constructed of 100% corn fiber for long-lasting durability. Hair-like follicles on each fiber trap that hold dust particles for fast cleanup.

ID No.	Overall Length	Qty.	Unit	Price
8 BWK-951TEA	39"	1	Each	8.82



### F MAXIPLUS® PROFESSIONAL ANGLE BROOM

Great for floors, under furniture and hard-to-reach corners. Washable, flagged-tip bristles sweep even the finest of particles and are unaffected by water, alkalis, acids, grease or oil. Won't wear down, break or fall out. Solid bristle block means no chance of separation from shroud. Deeper thread insert to prevent breaking of handle tip. Sturdier, thicker handle adds extra durability. Wider 14" sweeping surface for faster cleaning. Plastic angled shroud has patented handle-locking mechanism. ♻️ ♻️ ♻️

ID No.	Overall Length	Qty.	Unit	Price
9 DVO-91351EA ★	51"	1	Each	26.94

★ Contains 95% recycled PET fiber.



### G HEAVY-DUTY DUST PAN

Handy dust pan features a tapered front edge to help simplify sweeping up. Heavy-duty plastic provides commercial-grade durability.

ID No.	Color	Material	Width	Unit	Price
10 RCP-2005 CHA	Charcoal	Polypropylene	8 1/4"	Each	8.98





## A STEEL BOOK CART

Mobilize your books, magazines or research collections. Sturdy steel all welded construction with four casters (two locking) for easy mobility. No assembly required. Manufacturer's limited lifetime warranty.

ID No.	Finish	W x D x H	Shpg. Wt.	Unit	Price
<b>Double Sided Book Cart</b> —Six shelves.					
1	SAF-5357SA	Sand	36" x 18½" x 43½"	68 lbs.	Each <del>632.00</del>
<b>Single Sided Book Cart</b> —Three shelves.					
2	SAF-5358SA	Sand	36" x 14½" x 43½"	46 lbs.	Each <del>526.00</del>

## B SCOOT™ BOOK CART

Perfect for use in libraries, schools or any work area with a large collection of books. All-steel construction with unique hole pattern design is accented by tubular steel legs. Four oversized casters for easy maneuverability. Black powder coat finish for durability. Manufacturer's limited lifetime warranty.

ID No.	Finish	W x D x H	Shpg. Wt.	Unit	Price
<b>Double Sided Cart</b> —Three 8" deep slanted shelves on each side of cart. 12" clearance between shelves. Includes a height-adjustable file pocket.					
3	SAF-5335BL *	Black	41¼" x 17¾" x 41¼"	73 lbs.	Each <del>506.00</del>
<b>Single Sided Cart</b> —Three 12½" deep slanted shelves. 12½" space between shelves.					
4	SAF-5336BL *	Black	33" x 14¼" x 44¼"	60 lbs.	Each <del>409.00</del>

\* GREENGUARD Certified.



## C CARRY-ALL CART/MAIL CART

7" deep top basket can accommodate letter- or legal-size files with included adjustable file rods. Sturdy bottom basket with 4" raised sides. Heavy-duty metal tube and wire construction resists scratches and withstands constant use. Snaps together in minutes without tools. Shelf and basket height adjustable in 1" increments. Four 4" nylon casters. Manufacturer's limited five-year warranty.

ID No.	Finish	W x D x H	Shpg. Wt.	Unit	Price
5	ALE-MC3518SR	Silver	34¾" x 18" x 39½"	29 lbs.	Each <del>369.00</del>

## D THREE-TIER WIRE CART WITH BASKET

Sturdy and solid wire cart for mobile shelving needs. Includes four 4" casters (two locking). Black Anthracite finish for wet and dry usages. Shelves and baskets adjust in 1" increments. 500 lbs. total weight capacity. Easy to assemble—no tools required. Manufacturer's limited five-year warranty.

ID No.	Finish	W x D x H	Shpg. Wt.	Unit	Price
<b>Four 4" Casters</b> —Two wire shelves, one wire basket, three shelf liners, four 35" poles and one pull handle.					
6	ALE-SW543018BA *	Black Anthracite	34" x 18" x 40"	41 lbs.	Each <del>270.00</del>
<b>Four 3" Casters</b> —Two wire shelves, one wire basket, four poles and one pull handle.					
7	ALE-SW342416BA *	Black Anthracite	28" x 16" x 39"	26 lbs.	Each <del>179.00</del>

\* Meets or Exceeds ANSI/BIFMA Standards.

## E THREE-SHELF WIRE CART WITH LINERS

Three adjustable shelves with pull handle. Includes three shelf liners, four 35" poles and four casters (two locking). Shelves adjust in 1" increments. 500 lbs. total weight capacity on casters. Easy to assemble—no tools required. Manufacturer's limited five-year warranty.

ID No.	Finish	W x D x H	Shpg. Wt.	Unit	Price
8	ALE-SW333018SR *	Silver	34½" x 18" x 40"	27 lbs.	Each <del>249.00</del>
9	ALE-SW322416SR *	Silver	28½" x 16" x 39"	24 lbs.	Each <del>161.00</del>

\* Meets or Exceeds ANSI/BIFMA Standards.



**Fast Delivery**  
In most cases, the next business day!

# Office Furnishings Carts/Media & Beverage



## A THREE-SHELF SERVICE CART

Versatile; for audio/video, filing, food service. Shelves feature 1/4" lip on three sides and one flat side for easy loading. Brushed aluminum uprights, dual molded handles. Four 4" non-marking swivel casters. Manufacturer's limited one-year warranty.

ID No.	Finish	W x D x H	Shpg. Wt.	Unit	Price
1 RCP-3424-88 BLA	Black	18 1/2" x 33 1/2" x 37 3/4"	30 lbs.	Each	428.72
2 RCP-342488PM	Platinum	18 1/2" x 33 1/2" x 37 3/4"	30 lbs.	Each	428.72



## B MOBILE FILE CART

Keep paperwork handy when you need it and out of the way when you don't. Wheels glide with ease for mobility and lock for stability. Accommodates letter or legal size hanging files. Four 2" dual-wheel hooded casters (2 locking). Manufacturer's limited five-year warranty.

ID No.	Finish	W x D x H	Shpg. Wt.	Unit	Price
3 ALE-FM642212G	Silver	22 1/4" x 12 3/4" x 25 1/4"	16 lbs.	Each	189.00

Meets or Exceeds ANSI/BIFMA Standards.



## C EXECUTIVE SERVICE CART

The cart brings the utmost in style, durability, and functionality to its users. Provides 20% more top-shelf capacity than previous Rubbermaid utility carts and accommodates two RCP bus boxes sold separately). The sleek, contemporary styling is ideal for front or back of house applications. The rolling utility cart has wrap-around end panels and solid base bumper. Smooth surface is easier to clean and maintain. Offers simple assembly with a soft mallet; all-plastic construction with easy snap-and-lock assembly. Manufacturer's limited one-year warranty.

ID No.	Finish	W x D	Shpg. Wt.	Unit	Price
4 RCP-9T6800BK	Black	20 1/8" x 38 3/8"	38 lbs.	Each	397.50

## D HEAVY-DUTY UTILITY CART

Perfect for transporting materials, supplies, and heavy loads in almost any environment. Ergonomically-designed push handle provides optimum hand placement and push height, improving control and worker safety. Molded-in storage compartments, holsters, hooks, and notches for ideal storage. The rolling utility cart features molded-in customizable fittings. High-density structural resin construction. Easy-access bottom shelf. Best-in-class casters to meet the most demanding environments.

ID No.	Color	W x D x H	Capacity	Shpg. Wt.	Unit	Price
5 RCP-452088BG	Beige	25 1/2" x 45 1/2" x 32 1/2"	500 lbs.	38 lbs.	Each	403.14
6 RCP-452088BK	Black	25 1/2" x 45 1/2" x 32 1/2"	500 lbs.	38 lbs.	Each	403.16
7 RCP-450088BG	Beige	17 1/2" x 38 1/2" x 38 3/8"	500 lbs.	42 lbs.	Each	354.92
8 RCP-450088BK	Black	17 1/2" x 38 1/2" x 38 3/8"	500 lbs.	30 lbs.	Each	354.89

## E SERVICE/UTILITY CARTS

Quiet, lightweight and easy to maneuver cart. Two large trays hold items to be transported. 300 lb. capacity. Molded-in handle with handy storage compartments. Four 5" non-marking swivel casters. Manufacturer's limited one-year warranty.

ID No.	Finish	W x D x H	Shpg. Wt.	Unit	Price
9 RCP-9T6700BLA	Black	24" x 40" x 31 1/4"	43 lbs.	Each	354.92
10 RCP-9T6600BLA	Black	34 1/4" x 17 3/4" x 32 3/8"	31 lbs.	Each	310.80



## A HOSPITALITY SERVICE CART

Greet guests and employees with hospitality. Drop leaf design extends serving area (to 56¼") while the locking double door cabinet contains a height-adjustable interior shelf for storage of hospitality supplies. Spacious drawer organizes silverware, napkins and smaller items. Four Casters (2 Locking). Manufacturer's limited lifetime warranty.

ID No.	Finish	W × D × H	Shpg. Wt.	Unit	Price
1 SAF-8962MH	Mahogany	32½" × 20½" × 38¼"	143 lbs.	Each	779.00

## B MOBILE BEVERAGE CART

Suitable for lobbies, meeting spaces, breakrooms and conference rooms. Melamine top features 1½" high wire rails to help prevent accidental spills. Locking cabinet features one adjustable, 29" w × 16½" d steel shelf. 8¾" high open storage area. Mobile on 3½" casters (two locking).

ID No.	Finish	W × D × H	Shpg. Wt.	Unit	Price
2 SAF-8964BL	Black	33½" × 21¾" × 43"	91 lbs.	Each	602.00

## C MOBILE REFRESHMENT CENTER

Compact, yet offers ample storage for your day-to-day breakroom supplies and meeting spaces. Refreshment center features ¾" wood laminate construction and double-door design with a fixed interior shelf. Heat-resistant countertop has a 1¼" raised lip to contain spills. Four 2" casters (2 locking). Manufacturer's limited lifetime warranty.

ID No.	Finish	W × D × H	Shpg. Wt.	Unit	Price
3 SAF-8953MH	Mahogany	23" × 18" × 31"	67 lbs.	Each	355.00



## D REFRESHMENT STAND

Big enough to accommodate a microwave or coffee maker as well as your kitchen supplies. Double silver steel doors each have three built-in shelves for frequently used items. Internal shelving can accommodate larger items. Finished in stain- and scratch-resistant laminate. Glides. Manufacturer's limited 90-day warranty.

ID No.	Finish	W × D × H	Shpg. Wt.	Unit	Price
4 VRT-35157	Black/White	29½" × 21" × 33"	100 lbs.	Each	454.82

## E MOBILE DELUXE COFFEE BAR

Functional unit ideal for use in coffee service areas. Complete with pull-out drawer and double-door storage area for coffee making and service accessories. Top has raised lip to prevent spills. Set on four casters. Manufacturer's limited 90-day warranty.

ID No.	Finish	W × D × H	Shpg. Wt.	Unit	Price
5 VRT-VF96033	Cherry	23" × 19" × 30¾"	68 lbs.	Each	364.00

## F COUNTERTOP SERVING CART

Perfect for the office, breakroom, or home. Three drawers provide additional storage space for tools or supplies. Two large metal shelves hold a variety of items. Durable steel frame with attractive silver powder coat finish. Rolls smoothly on four 3" industrial casters, two locking. Solid wood top and MDF drawers. Countertop surface measures 34½" W × 19¾" D.

ID No.	Finish	W × D × H	Shpg. Wt.	Unit	Price
6 VRT-VF53039	Silver/Brown	35½" × 19¾" × 34¾"	66 lbs.	Each	349.00

Prices subject to change without notice.  
Visit our website for the latest pricing and product information.



# Office Furnishings Cleaning & Sanitation/Sprays & Wipes



## A DISINFECTANT SPRAY

This tuberculocidal, virucidal, fungicidal, and bactericidal formula kills 99.9% of germs on hard, nonporous surfaces and is effective against over 100 microorganisms including Influenza A Virus, MRSA, Norovirus, Rhinovirus, Poliovirus Type 1, Hepatitis A virus, Hepatitis B virus and HIV-1 (AIDS Virus) when used as directed. Effective against *Mycobacterium bovis* BCG (TB) in two minutes (pre-cleaned surfaces). Eliminates odors and prevents the growth of mold and mildew. Use on showers, sinks, countertops, around toilet areas, toys, telephones, garbage bins, waiting rooms and in laboratories.

ID No.	Size	Scent	Qty.	Unit	Price
1 RAC-74276EA ★	19 oz Aerosol	Country Scent®	1	Each	14.49
2 RAC-74828EA ★	19 oz Aerosol	Crisp Linen®	1	Each	14.49
3 RAC-84044EA ★	12.5 oz Aerosol	Crystal Waters	1	Each	10.91
4 RAC-04675EA ★	19 oz Aerosol	Fresh	1	Each	14.49
5 RAC-89097EA ★	19 oz Aerosol	Lavender	1	Each	14.49
6 RAC-04650EA ★	19 oz Aerosol	Original	1	Each	14.49
7 RAC-76075EA ★	19 oz Aerosol	Spring Waterfall®	1	Each	14.49

**Value Pack**—Stock up and save!

8 RAC-74276CT ★ \$	19 oz Aerosol	Country Scent®	12	Carton	173.88
9 RAC-74828CT ★ \$	19 oz Aerosol	Crisp Linen®	12	Carton	173.88
10 RAC-84044CT ★ \$	12.5 oz Aerosol	Crystal Waters	12	Carton	130.93
11 RAC-04675CT ★ \$	19 oz Aerosol	Fresh	12	Carton	173.88
12 RAC-89097CT ★ \$	19 oz Aerosol	Lavender	12	Carton	173.88
13 RAC-04650CT ★ \$	19 oz Aerosol	Original	12	Carton	173.88
14 RAC-76075CT ★ \$	19 oz Aerosol	Spring Waterfall®	12	Carton	173.88

★ Complies with the VOC (Volatile Organic Compound) limits, including California; Fully registered with the Federal EPA and each of the 50 State EPA agencies (and the District of Columbia); Compliant with TSCA regulations; Meets OSHA Bloodborne Pathogens Standards; Meets A0AC Germicidal Spray Product Test standards for hospital aerosol disinfectants; NSF Classification D1.

## B DAILY CLEANSING WIPES

Citric acid formula is free from ammonia, fragrance, dyes and harsh chemical residue. Suitable for use on food contact surfaces, baby and pet areas. ✓

ID No.	W x L	Scent	No. of Sheets	Qty.	Unit	Price
15 RAC-99117EA ★	7" x 8"	Unscented	35 per Canister	1	Each	6.22
16 RAC-99118EA ★	7" x 8"	Unscented	80 per Canister	1	Each	10.76
17 RAC-99255PK ★	7" x 8"	Unscented	80 per Canister	2	Pack	18.85
18 RAC-99119PK ★	7" x 8"	Unscented	80 per Canister	3	Pack	23.86

★ Complies with All Various State Phosphate Regulations; Complies with TSCA Regulations; Complies with the VOC Limits.

## C DISINFECTING WIPES

Each thick, pre-moistened wipe kills 99.9% of viruses and bacteria on hard non-porous surfaces when used as directed. Ideal to clean, disinfect and deodorize. Wipes also remove more than 95% of allergens, including pet dander, dust mites and pollen. Use on kitchen counters, appliances, stove tops, cabinets, door knobs, light switches, floors, garbage cans, toilet exteriors, bathtubs and sinks. The wipes are also safe to use on electronics including smartphones, tablets and remote controls. ✓

ID No.	W x L	Scent	No. of Sheets	Qty.	Unit	Price
19 RAC-98481EA ★	7" x 8"	Berry & Basil	80 per Canister	1	Each	10.76
20 RAC-97181EA ★	7" x 8"	Mango & Hibiscus	80 per Canister	1	Each	10.76
21 RAC-89346 ★	7" x 8"	Crisp Linen®	80 per Canister	1	Each	10.76
22 RAC-89347 ★	7" x 8"	Early Morning Breeze™	80 per Canister	1	Each	10.76
23 RAC-75599EA ★	7" x 8"	Green Apple & Aloe	80 per Canister	1	Each	10.76
24 RAC-82159PK ★	7" x 8"	Lemon & Lime Blossom®	35 per Canister	3	Pack	15.25
25 RAC-77182EA ★	7" x 8"	Lemon & Lime Blossom®	80 per Canister	1	Each	10.76
26 RAC-80296PK ★	7" x 8"	Lemon & Lime Blossom®	80 per Canister	2	Pack	18.85
27 RAC-84251PK ★	7" x 8"	Lemon & Lime Blossom®	80 per Canister	3	Pack	29.99
28 RAC-78849EA ★	7" x 8"	Lemon & Lime Blossom®	110 per Canister	1	Each	13.94
29 RAC-77925EA ★	7" x 8"	Ocean Fresh®	80 per Canister	1	Each	10.76
30 RAC-93010 ★	7" x 8"	Ocean Fresh®	110 per Canister	1	Each	13.94

★ Complies with the VOC (Volatile Organic Compound) limits, including California; Fully registered with the Federal EPA and each of the 50 State EPA agencies (and the District of Columbia). Each product bears an EPA Registration Number on the product label; Complies with TSCA regulations.



## D 4 IN ONE DISINFECTANT & SANITIZER

Disinfects hard surfaces with 24 EPA-registered kill claims. Sanitize soft surfaces in just 30 seconds and sanitize the air, killing odor-causing bacteria. Reduce pet dander, dust mites and other allergens which can trigger allergies and asthma. No precleaning is required.

ID No.	Size	Scent	Qty.	Unit	Price
31 CLO-31043	14 oz Aerosol Can	Citrus	1	Each	9.99

## E DISINFECTING AEROSOL SPRAY

Kills relevant bacteria, viruses and fungi that can cause serious illnesses and infection. EPA-registered to kill as many as 64 microorganisms. Kills the majority of bacteria on its EPA Master Label in three minutes. Safe to use on a wide variety of hard surfaces, it deodorizes and actually eliminates the bacteria that cause bad odors.

ID No.	Size	Scent	Qty.	Unit	Price
32 CLO-38504	19 oz Aerosol Can	Fresh	1	Each	12.23

## F DISINFECTING WIPES

Clean and disinfect multiple surfaces in one easy step. Sanitizing wipes power through grease, soap scum and grime and kill germs. Work great on a variety of hard, non-porous surfaces including finished hardwood, stainless steel, mirrors and glass.

ID No.	W x L	Scent	No. of Sheets	Qty.	Unit	Price
33 CLO-30208PK ★	7" x 8"	Fresh Scent/Citrus Blend™	75 per Canister	3	Pack	26.56
34 CLO-01686EA ★	7" x 8"	Orange Fusion™	75 per Canister	1	Each	11.89

**Value Pack**—Stock up and save!

35 CLO-01594CT ★ \$	7" x 8"	Crisp Lemon	35 per Canister	12	Carton	77.03
36 CLO-01593CT ★ \$	7" x 8"	Fresh Scent	35 per Canister	12	Carton	77.03
37 CLO-15949CT ★ \$	7" x 8"	Fresh Scent	75 per Canister	6	Carton	69.77
38 CLO-01599 ★ \$	7" x 8"	Fresh Scent/Citrus Blend™	75 per Canister	2	Pack	20.45
39 CLO-30112 ★ \$	7" x 8"	Fresh Scent/Citrus Blend™	35 per Canister	3	Pack	16.03
40 CLO-15948CT ★ \$	7" x 8"	Lemon Fresh	75 per Canister	6	Carton	69.77
41 CLO-01686CT ★ \$	7" x 8"	Orange Fusion™	75 per Canister	6	Carton	71.31

★ CLO-30208PK, CLO-01686EA, CLO-01594CT, CLO-01593CT, CLO-15949CT, CLO-01599, CLO-30112, CLO-15948CT, CLO-01686CT—Not for use on dishes, glassware or eating utensils. Not recommended for use on unpainted wood, unfinished, unsealed, unpainted, waxed, oiled or worn surfaces.





## boardwalk.

### A DISINFECTING WIPES

Convenient cleaning wipes that disinfect hard surfaces in one easy step. Bleach- and alcohol-free formula kills 99.9% of E. coli, Salmonella, Staph and Strep. Also effective against Influenza A and H1N1 flu virus. Ready-to-use, premoistened wipes are great for offices, clinics, day care centers, restaurants, schools and nursing homes. Easy dispensing canister.

ID No.	W x L	Scent	No. of Sheets	Qty.	Unit	Price
1 BWK-454W35	7" x 8"	Fresh	35 per Canister	12	Carton	55.94
2 BWK-454W753PK	7" x 8"	Fresh	75 per Canister	3	Pack	22.93
3 BWK-454W75	7" x 8"	Fresh	75 per Canister	6	Carton	44.10
4 BWK-455W35	7" x 8"	Lemon	35 per Canister	12	Carton	55.94
5 BWK-455W753PK	7" x 8"	Lemon	75 per Canister	3	Pack	22.93
6 BWK-455W75	7" x 8"	Lemon	75 per Canister	6	Carton	44.10

### B NATURAL ALL PURPOSE WIPES

Natural, all-purpose cleaning wipes are non-toxic, have no harsh fumes, and contain no harmful chemicals. Durable cloth wipes will not tear and can be used on multiple surfaces. Convenient wipes keep your surfaces clean without leaving residue.

ID No.	W x L	Scent	No. of Sheets	Qty.	Unit	Price
7 BWK-4736EA *	7" x 8"	Unscented	75 per Canister	1	Each	10.59
8 BWK-4736 *	7" x 8"	Unscented	75 per Canister	6	Carton	63.29

\* CGMP; EPA Safer Choice Label.



### C FURNITURE POLISH

Brings back the beauty. Shines, polishes and dusts wood furniture, cabinets, paneling, vinyl and leather in one step.

ID No.	Size	Scent	Qty.	Unit	Price
9 SJN-697264EA	14.2 oz Can	Sweet; Woody	1	Each	10.47
10 SJN-697831EA	9.7 oz Aerosol	Lemon	1	Each	12.37
11 SJN-697831	9.7 oz Aerosol	Lemon	12	Carton	148.40
12 SJN-301168EA	14.2 oz Aerosol	Lemon	1	Each	11.50
13 SJN-301168	14.2 oz Aerosol	Lemon	6	Carton	68.85
14 SJN-697834EA	9.7 oz Aerosol	Orange Clean	1	Each	12.37

### D WIPES

Premoistened to clean, polish and protect furniture with no wax buildup. Great for hard-to-reach areas. Use on furniture, cabinets, paneling, vinyl, marble and leather.

ID No.	W x L	No. of Sheets	Qty.	Unit	Price
15 SJN-624489PK	7" x 10"	24	24	Pack	9.38
<b>VALUE PACK</b> —Stock up and save!					
16 SJN-624489	7" x 10"	24	12	Carton	112.59



### E FURNITURE POLISH

For superior protection of wood finishes. Cleans, shines and conditions without leaving a waxy buildup. Helps prevent drying and cracking. Finish resists dust and fingerprints.

ID No.	Size	Scent	Qty.	Unit	Price
17 RAC-74035EA *	12.5 oz Aerosol	Fresh Lemon	1	Each	7.46
<b>VALUE PACK</b> —Stock up and save!					
18 RAC-74035CT *	12.5 oz Aerosol	Fresh Lemon	12	Carton	89.27

\* Complies with the VOC (Volatile Organic Compound) limits, including California.



### F OIL SOAP

Vegetable oil-based cleaner for mopping wood floors, paneling and other large wood surfaces. Cleans finished wood and hard surfaces.

ID No.	Size	Scent	Qty.	Unit	Price
<b>CONCENTRATE</b> —Makes 64 gallons of ready-to-use solution.					
19 CPC-01103EA	1 gal Bottle	Fresh	1	Each	26.33
20 CPC-01103CT	1 gal Bottle	Fresh	4	Carton	103.31

Prices subject to change without notice.  
Visit our website for the latest pricing and product information.

# Office Furnishings Cleaning & Sanitation/Hand Soaps & Odor Control



## boardwalk

### A SOAP DISPENSER

Holds a large sealed refill in a remarkably small footprint. Great for locations where a smaller, more traditional dispenser is preferred. Features skylight with an extra-large site window. One hand push operation. Optional key lock available. For use with: Boardwalk 1250 mL Refills.

ID No.	Color	W x D x H	Qty.	Unit	Price
1 BWK-8350 *	Gray	6.1" x 10.6" x 5.1"	1	Each	7.07

#### ALSO CONSIDER:

ID No.	Description	Qty.	Unit	Price
2 BWK-8300 *	Foam Handwash, Light Amber/Fruity; 1250 mL Refill	4	Carton	104.63
3 BWK-8400 *	Fragrance-Free; 1250 mL Refill	4	Carton	89.87

\* ADA Compliant.

BWK-8400—EcoLogo Certified; Green Seal Certified.



### B ES8 SOAP TOUCH-FREE DISPENSER

Always-ready, touch-free hand soap dispenser with a coin cell battery integrated into the refill. Elegant design complements décor. Uses PURELL® ES8 1200 ml HEALTHY SOAP® refills. Dispenser and formulation are calibrated to provide the optimal dose for effective hand hygiene. LOCK OR NOT™ technology can convert to a locking system.

ID No.	Color	W x D x H	Qty.	Unit	Price
4 GOJ-773401 *	Graphite	5.25" x 8.8" x 12.13"	1	Carton	116.74
5 GOJ-773001 *	White	5.25" x 8.8" x 12.13"	1	Carton	116.74

\* ADA Compliant.

#### ALSO CONSIDER:

ID No.	Description	Qty.	Unit	Price
6 GOJ-777002	Foam Soap, Clear/Fragrance-Free; 1200 mL Dispenser Refills	2	Carton	127.43

### C ES6 SOAP TOUCH-FREE DISPENSER

Reliable touch-free soap dispenser. Elegant design complements décor. Dispenser and formulation are calibrated to provide the optimal dose for effective hand hygiene. Uses PURELL® ES6 1200 mL HEALTHY SOAP® refills.

ID No.	Color	W x D x H	Qty.	Unit	Price
7 GOJ-643401 *	Graphite	5.25" x 8.8" x 12.13"	1	Carton	103.90
8 GOJ-643001 *	White	5.25" x 8.8" x 12.13"	1	Carton	103.90

\* ADA Compliant.

#### ALSO CONSIDER:

ID No.	Description	Qty.	Unit	Price
9 GOJ-647002	Foam Soap, Clear/Fragrance-Free; 1200 mL Dispenser Refills	2	Carton	114.62

### D ES4 SOAP PUSH-STYLE DISPENSER

Reliable and cost-effective push-style soap dispenser. Elegant design complements décor. For use with: PURELL® ES4 1200 mL HEALTHY SOAP Refills.

ID No.	Color	W x D x H	Qty.	Unit	Price
10 GOJ-503401 *	Graphite	4.88" x 8.8" x 11.38"	1	Carton	27.54
11 GOJ-503001 *	White	4.88" x 8.8" x 11.38"	1	Carton	27.54

\* ADA Compliant.

#### ALSO CONSIDER:

ID No.	Description	Qty.	Unit	Price
12 GOJ-507002	Foam Soap, Clear/Fragrance-Free; 1200 mL Dispenser Refills	2	Carton	77.15



### E AIR™

Doesn't just mask odors, it cleans away odors with OdorClear Technology, leaving your air with a light, fresh scent.

ID No.	Scent	Size	Qty.	Unit	Price
13 PGC-97810PK	Gain® Original	2 x 8.8 oz Aerosol	2	Pack	12.50
14 PGC-97794PK	Hawaiian Aloha	2 x 8.8 oz Aerosol	2	Pack	12.50
15 PGC-97799PK	Linen & Sky	2 x 8.8 oz Aerosol	2	Pack	12.50
16 PGC-97805PK	Spring & Renewal	2 x 8.8 oz Aerosol	2	Pack	12.50



### F SANITIZING SPRAY

When used as directed, sanitizing spray destroys odors in the air and kills 99.9% of odor-causing bacteria at the source, so odors do not come back.

ID No.	Scent	Size	Qty.	Unit	Price
17 RAC-76940EA *	Energizing Citrus Zest	10 oz Aerosol	1	Each	6.10
18 RAC-79196EA *	Rejuvenating Morning Linen	10 oz Aerosol	1	Each	6.10
19 RAC-76938EA *	Revitalizing Fresh Breeze	10 oz Aerosol	1	Each	6.10

\* Complies with the VOC (Volatile Organic Compound) limits, including California; Fully registered with the Federal EPA and each of the 50 State EPA agencies (and the District of Columbia). Each product bears an EPA Registration Number on the product label; Complies with TSCA regulations.



### G AIR FRESHENER

Fights strong and persistent odors with a clean fragrance. Use in commercial, industrial or institutional buildings.

ID No.	Scent	Size	Qty.	Unit	Price
20 SJN-682263EA	Hawaiian Breeze	13.8 oz Aerosol	1	Each	4.62
21 SJN-682263	Hawaiian Breeze	13.8 oz Aerosol	12	Carton	55.47
22 SJN-682262EA	Super Fresh	13.8 oz Aerosol	1	Each	4.62
23 SJN-682262	Super Fresh	13.8 oz Aerosol	12	Carton	55.47



### H SCENTED OIL AIR FRESHENER

Invigorate your senses and enhance your surroundings. Our nature-inspired, true-to-life premium fragrances with essential oils will infuse any small space with a fresh, clean scent. Elegant modern, stylish glass diffuser complements any decor. Provides a long-lasting, memorable experience. Freshens up to 30 days.

ID No.	Scent	Size	Qty.	Unit	Price
24 BRI-900115EA	Calm Waters & Spa	2.5 oz Diffuser	1	Each	7.79
25 BRI-900134EA	Fresh Petals & Peach	2.5 oz Diffuser	1	Each	7.79
26 BRI-900021	Hawaiian Blossoms & Papaya	2.5 oz Diffuser	1	Each	7.79
27 BRI-900022	Macintosh Apple & Cinnamon	2.5 oz Diffuser	1	Each	7.79



## A GALLERY WALL CLOCK

Generous size makes this clock easy-to-read from a distance. Large numbers can be viewed by all in an office. Bold, black case makes clock stand out. 1 AA (sold separately). Manufacturer's limited one-year warranty.



ID No.	Case Color	Dial Dia.	Unit	Price
1 MIL-625166	Black	14.5"	Each	69.99



## B ALTON AUTO DAYLIGHT SAVINGS™ WALL CLOCK

Automatically adjusts for daylight-saving time. Easy-to-read white dial with large numerals. Shatter-resistant cover protects your timepiece. Satin finish on case looks elegant and adds class. 1 AA (sold separately). Manufacturer's limited one-year warranty.



ID No.	Case Color	Dial Dia.	Unit	Price
2 MIL-625323	Black	12.25"	Each	56.69



## C ELECTRIC CONTEMPORARY CLOCK

Top quality, reliable electric clock. No need to change batteries! Highly accurate with 5' UL-rated cord and movement. Sharp appearance for modern office. Shatter resistant lens. Manufacturer's one-year limited warranty.



ID No.	Case Color	Dial Dia.	Unit	Price
3 ILC-67801103	Black	12.5"	Each	57.59

\* Contains a minimum of 18% total recycled content (case contains 30% post-consumer recycled content).



## D QUARTZ SLIMLINE CLOCK

Large, easy-to-read numerals with a sleek modern design. Non-yellowing white dial. Top quality movement for years of dependable accuracy. Shatter resistant lens. 1 AA (sold separately). Manufacturer's one-year limited warranty.



ID No.	Case Color	Dial Dia.	Unit	Price
4 ILC-67300002	Black	12"	Each	44.99

\* Contains a minimum of 18% total recycled content (case contains 30% post-consumer recycled content).

## universal.

### E WHISPER QUIET CLOCK

Large, easy-to-read numerals. Silent sweep movement eliminates ticking sounds. Large, easy-to-read numerals. Crystal clear convex plastic face is shatter-resistant. Second hand. 1 AA battery (sold separately). 1 AA (sold separately). Manufacturer's limited one-year warranty.

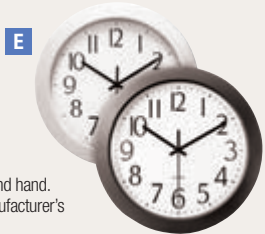

ID No.	Case Color	Dial Dia.	Unit	Price
5 UNV-10451	Black	9.5"	Each	34.66
6 UNV-10461	White	9.5"	Each	34.95

## universal.

### F DELUXE 13 1/2" INDOOR/OUTDOOR ATOMIC CLOCK

Fully sealed, weather-resistant case and large, easy-to-read numerals on its face make this clock ideal for high-humidity, outdoor environments. Clock maintains radio contact with the National Bureau of Standards' atomic clock in Boulder, Colorado, ensuring up-to-the-minute accuracy, precision and reliability. Automatically syncs up with Daylight Savings Time changes within the continental US time zones: Eastern (EST), Central (CST), Mountain (MST) & Pacific (PST). 1 AA (sold separately). Manufacturer's limited one-year warranty.



ID No.	Case Color	Dial Dia.	Unit	Price
7 UNV-10417	Black	12"	Each	52.92

\* Only continental US time zones: Eastern (EST), Central (CST), Mountain (MST) & Pacific (PST) are supported.



### G KENWICK WALL CLOCK

Easy-to-read Arabic numerals. Thick, black case creates a distinctive look. Bold, black hour and minute hands stand out against white dial face. 1 AA (sold separately). Manufacturer's one-year warranty.



ID No.	Case Color	Dial Dia.	Unit	Price
8 MIL-625485	Black	11.25"	Each	23.63

## universal.

### H LARGE NUMERAL CLOCK WITH AUTO DAYLIGHT SAVINGS ADJUSTMENT

Classic wall clock with large, easy-to-read numerals can be seen even across a long room. Ideal for classrooms, offices and common areas. An internal chip automatically syncs the clock up with Daylight Savings Time changes — no radio frequency reception required. Crystal clear convex plastic face is shatter resistant. Second hand. 1 AA battery (sold separately). 1 AA (sold separately). Manufacturer's limited one-year warranty.



ID No.	Case Color	Dial Dia.	Unit	Price
9 UNV-10450	Black	12"	Each	47.38

## universal.

### I CLASSIC ROUND WALL CLOCK

Classic, simple and easy-to-read. Large clock face and bold numerals blend seamlessly in any environment from the home to the office. Minute tracking for precise readings. Crystal clear high-quality flat glass face. Second hand. 1 AA battery (sold separately). 1 AA (sold separately). Manufacturer's limited one-year warranty.



ID No.	Case Color	Dial Dia.	Unit	Price
10 UNV-10431	Black	11.5"	Each	33.55

## universal.

### J 24-HOUR ROUND WALL CLOCK

24-hour dial with hours (13-24) in red on inner diameter for military time at a glance. Minute track for precise reading. Energy-efficient design gets the most out of every battery, saving you time and money. Crystal clear high-quality flat glass face. 1 AA battery (sold separately). 1 AA (sold separately). Manufacturer's limited one-year warranty.

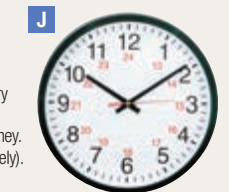

ID No.	Case Color	Dial Dia.	Unit	Price
11 UNV-10441	Black	11.5"	Each	33.55

Prices subject to change without notice.

Visit our website for the latest pricing and product information.



# Office Furnishings Clocks

## universal.

### A INDOOR/OUTDOOR ROUND WALL CLOCK

Shatter- and weather-resistant case, lens and dial make this clock tough enough for indoor or outdoor use. Built to handle the elements of nature. Clock is designed to get the most out of every battery, saving you time and money. 1 AA battery (sold separately). Manufacturer's limited one-year warranty.

ID No.	Case Color	Dial Dia.	Unit	Price
1 UNV-11381 ★	Black	12"	Each	47.97

★ RoHS Compliant.



## universal.

### B ROUND WALL CLOCK

Large face makes this clock easy to read from a distance. Clean text style provides an elegant simplicity. Designed to get the most out of every battery. Quartz movement helps ensure accuracy. Crystal clear convex plastic face is shatter resistant. 1 AA battery (sold separately). Manufacturer's limited one-year warranty.

ID No.	Case Color	Dial Dia.	Unit	Price
2 UNV-11641 ★	Black	12"	Each	37.47

★ RoHS Compliant.



## universal.

### C BOLD ROUND WALL CLOCK

Smaller dial diameter is ideal for smaller rooms and tight spaces without sacrificing readability. Lightweight design with a bold clock frame. Quartz movement ensures accurate timekeeping. Crystal clear high-quality flat glass face. Second hand. 1 AA battery (sold separately). Manufacturer's limited one-year warranty.

ID No.	Case Color	Dial Dia.	Unit	Price
3 UNV-10421 ★	Black	7.75"	Each	29.00

★ RoHS Compliant.



### D BLACK QUARTZ CONTRACT CLOCK

This reliable clock keeps accurate time at a very reasonable cost. Long lasting value! Classic traditional design. Body has UV protected lens and dial to prevent yellowing. Includes mounting hardware. 1 AA battery (sold separately). ♻️ ♻️

ID No.	Case Color	Dial Dia.	Unit	Price
4 ILC-67700002 ★	Black	12"	Each	39.50

★ Contains a minimum of 18% total recycled content (case contains 30% post-consumer recycled content).



### E SPOKANE WALL CLOCK

Flat glass crystal and flat rim prevent glare. Large, black Arabic numerals for easy and accurate reading. Brushed aluminum metal case offers a clean, modern look. 1 AA battery (sold separately). Manufacturer's limited one-year warranty.

ID No.	Case Color	Dial Dia.	Unit	Price
5 MIL-625450	Silver	14"	Each	52.95



### F CHRONICLE WALL CLOCK WITH LCD INSET

Lets you track day, date and month as well as time. Timepiece is part clock, part calendar for optimum time management. 1 AA battery (sold separately). Manufacturer's limited one-year warranty.

ID No.	Case Color	Dial Dia.	Unit	Price
6 MIL-625195	Gray	12"	Each	59.95



### G HAMILTON WALL CLOCK

12" diameter wall clock has a polished chrome finish, which gives it a sleek, modern look. Large, black Arabic numerals and hands are easy to read against the white dial. Quartz, battery operated movement. 1 AA battery (sold separately). Manufacturer's limited one-year warranty.

ID No.	Case Color	Dial Dia.	Unit	Price
7 MIL-625561	Silver	10.75"	Each	25.70



### H SILVER CONTEMPORARY CLOCK

With a silver case, this stylish clock delivers a classic feel with modern precision. Interior design selection and show room favorite! Large, high-contrast dial. Flat rim lens prevents glare. 1 AA battery (sold separately). ♻️ ♻️

ID No.	Case Color	Dial Dia.	Unit	Price
8 ILC-67818003 ★	Silver	12.25"	Each	51.50

★ Contains a minimum of 18% total recycled content (case contains 30% post-consumer recycled content).



## universal.

### I BRUSHED ALUMINUM WALL CLOCK

This contemporary 12 inch clock is 1.75 inches deep featuring a brushed steel finish. The large bold numerals on the white face provide extra clarity and readability. High quality quartz movement insures accurate timekeeping. Second hand. 1AA battery (sold separately). Manufacturer's limited one-year warranty.

ID No.	Case Color	Dial Dia.	Unit	Price
9 UNV-10425 ★	Silver	10.5"	Each	47.25

★ RoHS Compliant.



### J TALON AUTO DAYLIGHT-SAVINGS™ WALL CLOCK

Traditional style meets modern convenience with the Auto daylight-savings™ feature, which automatically adjusts for daylight-saving time, avoiding the hassle of manually resetting the clock. Spade hands create a distinctive look. Large clock diameter makes it easy to tell time from a distance. 1 AA battery (sold separately). Manufacturer's limited one-year warranty.

ID No.	Case Color	Dial Dia.	Unit	Price
10 MIL-625417	Cherry	11.75"	Each	52.95



## universal.

### K ROUND WOOD WALL CLOCK

Elegant style is perfect for executive offices and conference rooms. Solidly constructed with a cherry wood finish. Accurate quartz movement. Crystal clear high-quality glass face. Second hand. 1 AA battery (sold separately). Manufacturer's limited one-year warranty.

ID No.	Case Color	Dial Dia.	Unit	Price
11 UNV-10414	Cherry	9"	Each	50.48



### L TECHTIME II RADIO-CONTROLLED LCD WALL OR TABLE ALARM CLOCK

Accuwave DS™ clock automatically sets itself and adjusts for Daylight Saving Time, keeping you on time. Big 2" LCD display makes time, day, month and date easy to read. Use as wall or table clock as it features a folding stand for tabletop display. Features snooze alarm and radio signal strength indicator. 1 AA battery (sold separately). Manufacturer's limited one-year warranty.

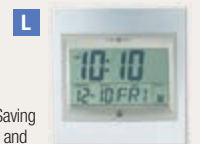

ID No.	Case Color	W x D x H	Unit	Price
12 MIL-625236	Silver/Titanium	8.75" x 1" x 9.25"	Each	68.96









## A LARGE CAPACITY GARMENT RACK

Coat rack accommodates 50 coat hangers. Delivered with three hangers. Flatpacked. Easy to assemble.  

ID No.	Finish	W × D × H	Hangers	Unit	Price
1 ABA-PMGROUP3	Black/ Silver Steel	63½" × 21¼" × 67½"	2 Hooks; 3 Hangers	Each	<del>324.00</del>



## B LUX GARMENT RACK

Stylish combination of steel tubing and wood detail. Features six accessory hooks and four casters, two locking. Holds up to 36 garment hangers. Six hangers included.  

ID No.	Finish	W × D × H	Hangers	Unit	Price
2 ABA-PMLUX6	Silver Steel/Wood Steel/Wood	44¾" × 21¾" × 70¾"	6 Hangers/ 6 Hooks	Each	<del>454.00</del>

**Double-Sided, Two-Shelf Rack**—Top and bottom shelves for storing hats and cases.

## C WAVY COAT TREE

Features six wood and metal hangers. Four coat/accessory knobs and an integrated umbrella stand with a water retainer. Weighted base for great stability.  

ID No.	Finish	W × D × H	Hooks	Unit	Price
3 ABA-PMWAVE	Silver Steel/Wood Steel/Wood	18¾" × 14" × 68½"	6 Hangers/ 4 Hooks/ 2 Knobs	Each	<del>200.00</del>



## D WIRE GARMENT RACK

Time-saving design assembles in minutes without tools. Strong welded wire construction. Double-sided for quick access to items. Rack features hanging rod for garments and five support hooks. Three shelves adjust in 1" increments and support up to 350 lbs. on each shelf. Four casters for quick mobility and two lock. Total unit capacity is 500 lbs. if used with casters. Hangers not included. 

ID No.	Finish	W × D × H	Unit	Price
4 ALE-GR364818BL	Black Steel	48" × 18" × 75"	Each	<del>391.00</del>
5 ALE-GR364818SR	Silver Steel	48" × 18" × 75"	Each	<del>391.00</del>



## E - F GARMENT RACKS



Powder-coated textured steel. Perforated shelves for garment ventilation. Adjustable leveling glides.

### E SINGLE-SIDED, TWO-SHELF RACK

A convenient top and bottom shelf provide ample storage space in addition to the hangers that are included with this free-standing contemporary garment rack. 

ID No.	Finish	W × D × H	Hangers	Unit	Price
6 QRT-20224	Black Steel	48" × 18½" × 61½"	12	Each	<del>808.13</del>

### F SINGLE-SIDED, ONE-SHELF RACK

Single-sided free-standing garment rack makes it easy to keep your office space looking neat and clean by providing a designated location for employees and guests to store their coats. Top shelf hold hats and other miscellaneous items.  

ID No.	Finish	W × D × H	Unit	Price
7 QRT-20214	Black Steel	48" × 18½" × 61½"	Each	<del>623.03</del>

## G METAL SHELF RACKS

Discreet shelf rack can be mounted to any wall for various storage needs. Single rail can hold hangers (sold separately) for an instant garment rack that does not take up valuable floor space.

ID No.	Finish	W × D × H	Unit	Price
8 QRT-20403	Black Steel	36" × 14½" × 6"	Each	<del>259.46</del>
9 QRT-20404	Black Steel	48" × 14½" × 6"	Each	<del>320.36</del>



## H METAL AND WOOD COAT HANGERS

Elegant and sturdy, this new design features a stylish combination of metal and wood. Curved shape is ideal for perfect care of coats.

ID No.	Width	Hanger Material	Qty.	Unit	Price
10 ABA-PMCIN6	16¾"	Wood; Steel	6	Set	<del>46.00</del>

Prices subject to change without notice.  
Visit our website for the latest pricing and product information.

# Office Furnishings Coat Racks/Stands and Umbrella Stands



## A CAFÉ WOOD COAT STAND

A classic design with contemporary flair. Five large coat pegs and five coat hooks on an easily-accessible rotating head. Large base with four feet for stability. Fast and easy tool-free assembly.

ID No.	Finish	W × H	Knobs	Unit	Price
1 ABA-PMCAFE	Wood	21¾" × 69½"	10	Each	200.00

## B – C METAL COSTUMERS

Steel tubing with rounded hooks. Optimized stability thanks to its weighted base or crossed base.

### B STAN3 COAT RACK

High-capacity coat rack. Kind to clothes thanks to rounded tips on coat pegs. Pegs are horizontally adjustable so clothes do not stack on each other. Umbrella holder can hold up to seven umbrellas. Great stability thanks to weighted 5-kilogram base. Powder coated black finish.

ID No.	Finish	W × H	Knobs	Unit	Price
2 ABA-PMSTAN3N	Steel	15" × 69¾"	8	Each	145.00

### C CHROMY COAT STAND

Provides six coat knobs, six accessory hooks and an integrated umbrella stand with water retainer. Rotating head for easy access to clothes. Weighted base for perfect stability. Easy assembly without tools.

ID No.	Finish	W × H	Knobs	Unit	Price
3 ABA-PMCLAS	Chrome Steel/Plastic	16" × 70½"	12	Each	196.00

### D VIENA COAT STAND

Provides four coat knobs, four accessory hooks and an integrated umbrella stand with water retainer. Rotating head for easy access to clothes. Weighted base for perfect stability. Easy assembly without tools.

ID No.	Finish	W × H	Knobs	Unit	Price
4 ABA-PMVIENAN	Steel	16" × 70½"	8	Each	167.00

### E FESTIVAL COAT STAND

Features a contemporary look. Stylish and functional. Includes five coat knobs, an umbrella stand and a water retainer. Weighted base for perfect stability. Easy assembly, no tools required.

ID No.	Finish	W × H	Knobs	Unit	Price
5 ABA-PMFESTYN	Steel	14" × 73¾"	5	Each	122.00
6 ABA-PMFEST	Steel/Wood	14" × 73¾"	5	Each	129.00

### F CLEO COAT STAND

Has ten coat pegs, umbrella holder and water retainer. Crossed base for an optimized stability.

ID No.	Finish	W × H	Knobs	Unit	Price
7 ABA-PMCLEON	Steel/Plastic	19¾" × 68¾"	10	Each	165.00

## G BRIO COAT STAND

High capacity with six knobs and three hooks. Kind to clothes thanks to the large rounded pegs. Smart umbrella holder (up to six umbrellas) and a water retainer. Rotating head for easy access to clothes. Great stability with its weighted base. Easy assembly without tools.

ID No.	Finish	W × H	Knobs	Unit	Price
8 ABA-PMBRION	Powder-Coated Steel; Plastic	13¾" × 66¼"	9	Each	114.00



## H COAT RACK

Free-standing metal coat rack features four double hooks to securely hold up to eight garments. Steel ball tip hooks help protect garments.

ID No.	Finish	W × H	Knobs	Unit	Price
<b>With Umbrella Stand—Bottom water receptacle.</b>					
9 SAF-4168BL	★ Metal	21" × 70"	8	Each	147.00
<b>Without Umbrella Stand</b>					
10 SAF-4163BL	★ Metal	21" × 70"	8	Each	113.00
11 SAF-4163CR	★ Metal	21" × 70"	8	Each	113.00

★ GREENGUARD Certified.



## I TRIANGULAR UMBRELLA STAND

Triangular umbrella stand offers a large capacity, holds up to twelve umbrellas. Clever umbrella cut-out design on the sides provide excellent ventilation and speeds up drying time. Equipped with a water retainer. Three interior hooks to hang pocket umbrellas. No tools required for assembly.

ID No.	Finish	W × D × H	Unit	Price
12 ABA-PMTRIA2N	Black Steel/Plastic	10¼" × 10¼" × 23¾"	Each	112.00
13 ABA-PMTRIA2M	Silver Steel/Black	10¼" × 10¼" × 23¾"	Each	112.00



**Great Service**

We can help you with selection & solutions.

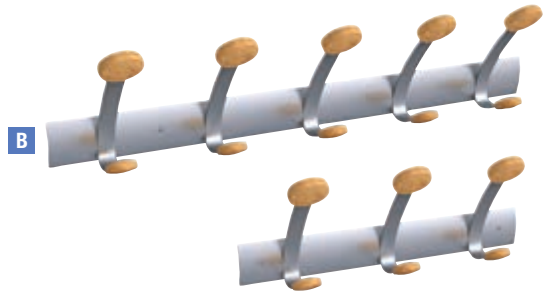
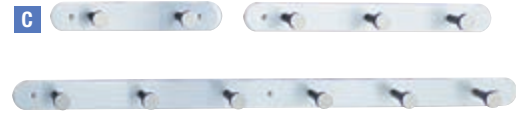

## A WALL-MOUNT COAT HOOKS

Wall mounted coat peg for all types of garments or accessories. Manufacturer's one-year warranty.

ID No.	Width	W x D x H	Hooks	Qty.	Unit	Price
1	18.11"	18.11" x 3" x 6.5"	3	1	EA	<del>47.00</del>
2	29.92"	29.9" x 3" x 6.5"	5	1	EA	<del>73.00</del>

## B WOODEN COAT HOOK

Gentle on your garments, thanks to its smooth, rounded wood tips. Accessory hooks add convenience. Very sturdy, can hang up to 45 lbs per hook. Stylish design blends seamlessly into any home or office environment. Elegant combination of metal and wood. Mounting hardware included.

ID No.	Number of Hangers/Hooks	Holds	Hook Material	Unit	Price
<b>Three-Wood Peg Wall Rack</b>					
3	3	Up to 45 lb	Wood; Steel	EA	<del>55.00</del>
<b>Five-Wood Peg Wall Rack</b>					
4	5	Up to 45 lb	Wood; Steel	EA	<del>89.00</del>



**Fast Delivery**  
In most cases, the next business day!



## C NAIL HEAD METAL COAT HOOKS

Satin aluminum hooks on matching back plate. Oversized circular hooks to help protect garments. Mounting hardware included.

ID No.	Finish	W x D x H	Hooks	Unit	Price
5	SAF-4200 ★ Satin Aluminum	12" x 2¾" x 2"	2	EA	<del>43.00</del>
6	SAF-4201 ★ Satin Aluminum	18" x 2¾" x 2"	3	EA	<del>62.00</del>
7	SAF-4202 ★ Satin Aluminum	36" x 2¾" x 2"	6	EA	<del>117.00</del>

★ GREENGUARD Certified.

## D COAT HOOKS

Chrome-plated double steel hooks with ball tips to help protect garments. Wall mounting hardware included.

ID No.	Finish	W x D x H	Hooks	Unit	Price
8	SAF-4160 ★ Chrome	6½" x 3" x 7"	2	EA	<del>16.00</del>
9	SAF-4161 ★ Chrome	18" x 3¾" x 7"	3	EA	<del>44.00</del>
10	SAF-4162 ★ Chrome	36" x 3¾" x 7"	6	EA	<del>89.00</del>

★ GREENGUARD Certified.

## E METAL COAT RACK

Made from beautifully brushed steel and aluminum with a nickel finish. Matching back plate arcs outward from the wall. Mounting hardware included.

ID No.	Finish	W x D x H	Hooks	Unit	Price
11	SAF-4203SL ★ Brushed Nickel Steel	7" x 4½" x 5¼"	2	EA	<del>27.00</del>
12	SAF-4204SL ★ Brushed Nickel Steel	10¾" x 4½" x 5¼"	3	EA	<del>35.00</del>
13	SAF-4205SL ★ Brushed Nickel Steel	14¼" x 4½" x 5¼"	4	EA	<del>41.00</del>

★ GREENGUARD Certified.

Prices subject to change without notice.  
Visit our website for the latest pricing and product information.

# Office Furnishings Coat Racks/Cubicle Hooks



## A CUBICLE GARMENT PEG

Garment peg slides easily over cubicle walls. Wooden knobs prevent damage to clothing. Keeps your space organized. Adjustable to partition width from 1½" to 4¼".

ID No.	Finish	Hooks	Hook Material	W × D × H	Unit	Price
1	ABA-PM1PARTBO	Metallic Gray	1	Wood	1½" × 1¾" × 4¾"	Each 21.00
2	ABA-PM2PARTBO	Metallic Gray	2	Wood	1½" × 1¾" × 7¾"	Each 29.00

## B OVER THE DOOR METAL AND PLASTIC COAT HOOK

This wall coat peg features three rounded black plastic pegs, one hook for accessories, one metallic holder, and two hooks to fit over the door. Very easy to affix without any tools thanks to its hook especially designed for doors (1.5 inches). Can also be used on cubicle partition walls of 1.5 inches. Very sturdy coat pegs that hold up to 20 pounds per hook. Stylish design that blends in with any office environment. Kind to clothes thanks to the large rounded tips on the ABS plastic coat pegs. Silver powder coated steel and ABS plastic.

ID No.	Number of Hangers/ Hooks	Holds	Hook Material	Unit	Price
3	ABA-PMS3P	3; 1	Up to 20 lb	Plastic	Each 60.00

## C HANGER SHAPED PARTITION COAT HOOK

Hook/hanger combination with anti-slip foam and one black plastic coat peg. Keeps garments secure; clean and wrinkle-free. Adjustable to partition widths from 1½" to 4¼".

ID No.	Finish	Hooks	Hook Material	W × D × H	Unit	Price
4	ABA-PMMOUSPART	Silver/Black	1	Metal; Foam; ABS	15" × 4½" × 7¾"	Each 51.00

## D MAGNETIC COAT PEG

Coat peg can be fixed on every metallic surface thanks to its strong magnet. Clothes won't slip with the foam shoulder pad. Can hang small accessories.

ID No.	Number of Hangers/ Hooks	Holds	Hook Material	Unit	Price
5	ABA-PMMAG	1	Up to 11 lbs	Steel	Each 24.00



## E PLASTIC COAT HOOKS

Features rounded knob to protect fabrics and keep your garments looking clean and wrinkle-free. Keeps your space organized. Easy-to-use.

ID No.	Finish	Hooks	Hook Material	W × D × H	Unit	Price
<b>Over The Panel</b>						
6	SAF-4224BL	1	Black	Plastic	1¾" × 5¼" × 4"	Each 25.00
<b>Over The Panel</b> —Adjustable for panels between 1¾" and 4" thick.						
7	SAF-4225BL	2	Black	Plastic	1¾" × 6½" × 7¾"	Each 36.00

\* GREENGUARD Certified.

## F ONYX™ PANEL/DOOR COAT HOOK

Coat hook features stylish black wire mesh construction. Fits over partitions and doors from 1½" to 2½" thick. Strong and sturdy to hold even bulky garments. Curved hook prevents damage.

ID No.	Finish	Hooks	Hook Material	W × D × H	Unit	Price
8	SAF-4229BL	1	Powder Coat	Steel	4¼" × 1¾" × 5"	Each 41.00

\* GREENGUARD Certified.

## G COAT HOOK

Double chrome hooks on a satin aluminum base. Features ball tips to help prevent damage to garments.

ID No.	Finish	Hooks	Hook Material	W × D × H	Unit	Price
<b>Over-The-Door - fits over doors up to 1¾" thick.</b>						
9	SAF-4166	1	Chrome	Steel	1½" × 4¼" × 8½"	Each 25.00
<b>Over-The-Panel - fits over doors up to 1¾" or panels 1½" to 3¾" thick.</b>						
10	SAF-4167	1	Satin Aluminum	Steel	1½" × 4¼" × 8½"	Each 26.00

\* GREENGUARD Certified.



## H WIRE MESH PARTITION COAT HOOK

Wire mesh double coat hook. Mounts on panels, partitions, and doors. Sturdy wire construction holds heavy coats, umbrellas and bags. Round knob end hooks will not snag or damage garments.

ID No.	Finish	W × D × H	Hook Material	Qty.	Unit	Price
11	UNV-20017	Black	4½" × 5¼" × 6"	Wire Mesh	1	Each 41.39



## I WIRE PARTITION ADDITIONS™ COAT HOOK

Universal mounting bracket. Double hook coat rack holds coats, sweaters, umbrellas and more. Simple wire design mounts easily on partition walls 1½" to 3" thick. 100% recyclable. No tools required.

ID No.	Color	W × D × H	Qty.	Unit	Price
12	FEL-75510	Black	4" × 5½" × 6"	1	Each 26.49



## J GARMENT HOOKS

Wire hook makes use of wall space to store coats, hats, accessories or office items. Slides over cubicle walls, partitions or doors with ease. Strong construction holds even the bulkiest coats. Fits over panels 1½" to 2½" thick.

ID No.	Finish	W × D × H	Hook Material	Qty.	Unit	Price
<b>Single-Sided Hook</b>						
13	ALE-CH1SR	Silver	½" × 3½" × 4¾"	Steel	2	Pack 10.00
<b>Double-Sided Hook</b>						
14	ALE-CH2SR	Silver	½" × 3¾" × 4¾"	Steel	2	Pack 15.00



## K METAL HOOKS

Securely sticks to surface. Removes cleanly with no surface damage.

ID No.	Finish	Hooks	Hook Material	W × D × H	Unit	Price
<b>Medium Hook - Holds 3 lbs.</b>						
15	MMM-FC12BNES	1	Brushed Nickel	Metal	1¼" × 1¼" × 3¼"	Pack 44.65
<b>Large Hook - Holds 5 lbs.</b>						
16	MMM-FC13BNES	1	Brushed Nickel	Metal	1¾" × 1¾" × 4½"	Pack 47.88

\* Limited Warranty and Limitation of Liability (for product sold in USA): This product will be free from manufacturing defects. If defective, your exclusive remedy shall be, at 3M's option, product replacement or refund. 3M will not be liable for any loss or damage arising from this product, whether direct, indirect, special, incidental or consequential.





Easy to apply

Easy to remove



Apply Strip



Press firmly



Slide hook up



Pull tab straight down



MMM-17068ES Wire Hook



MMM-170033ES Utility Hook



MMM-17067ES Toggle Hook



MMM-170001537NA



MMM-17091CLRCABP



MMM-17091CLR6ES Clear Hook



MMM-17067CLRES Clear Toggle Hook



MMM-17006CLR18ES Clear Mini Hook



MMM-17081ES Designer Hook



## A GENERAL PURPOSE HOOKS

General purpose hooks with adhesive are quick and easy to put up and take down. The hooks adhere firmly to flat surfaces but will not damage walls when removed.

ID No.	Size	Holds	Qty.	Unit	Price
<b>Utility Hooks</b> —Plastic hooks.					
1	MMM-170033ES *	Large	Up to 5 lbs	3 Pack	<del>12.29</del>
2	MMM-17003MPES	Large	Up to 5 lbs	14 Pack	<del>28.15</del>
3	MMM-17001ES * *	Medium	Up to 3 lbs	2 Pack	<del>4.50</del>
4	MMM-170016ES *	Medium	Up to 3 lbs	6 Pack	<del>12.29</del>
5	MMM-17001MPES *	Medium	Up to 3 lbs	20 Pack	<del>27.60</del>
6	MMM-17001S37NA *	Medium	Up to 3 lbs	37 Pack	<del>51.78</del>
7	MMM-17002MPES *	Small	Up to 1 lb	24 Pack	<del>27.60</del>
<b>Wire Hooks</b> —Metal-wire hooks.					
8	MMM-17069S14NA *	Large	Up to 5 lbs	14 Pack	<del>53.73</del>
9	MMM-17068ES *	Medium	Up to 3 lbs	2 Pack	<del>4.85</del>
<b>Toggle Hooks</b> —Metal-wire hooks.					
10	MMM-17065S35NA *	Medium	Up to 2 lbs	35 Pack	<del>63.15</del>
11	MMM-17067ES *	Small	Up to 0.5 lb	3 Pack	<del>4.45</del>
12	MMM-170679ES *	Small	Up to 0.5 lb	9 Pack	<del>12.03</del>
13	MMM-17067MPES *	Small	Up to 0.5 lb	28 Pack	<del>27.60</del>

\* Limited Warranty and Limitation of Liability (for product sold in USA): This product will be free from manufacturing defects. If defective, your exclusive remedy shall be, at 3M's option, product replacement or refund. 3M will not be liable for any loss or damage arising from this product, whether direct, indirect, special, incidental or consequential.

## B CLEAR HOOKS AND STRIPS

Clear hooks blend into surfaces so they don't distract from your decor. They hold firmly and remove cleanly without causing damage to surfaces.

ID No.	Size	Holds	Qty.	Unit	Price
<b>Clear Plastic Hooks</b> —Value Pack—Stock up and save!					
14	MMM-17091CLR6ES * \$	Medium	Up to 2 lbs	6 Pack	<del>15.90</del>
<b>Clear Plastic Hooks</b> —Cabinet Pack—Individually wrapped hooks with adhesive strips.					
15	MMM-17091CLRCABP *	Medium	Up to 2 lbs	50 Count	<del>80.00</del>
<b>Clear Toggle Hooks</b> —Metal-wire hooks.					
16	MMM-17067CLRES *	Small	Up to 0.5 lb	3 Pack	<del>5.35</del>
<b>Clear Toggle Hooks</b> —Metal-wire hooks—Value Pack.					
17	MMM-17067CLR9ES * \$	Small	Up to 0.5 lb	9 Pack	<del>14.45</del>
<b>Clear Mini Hooks</b> —Value Pack—Stock up and save!					
18	MMM-17006CLR18ES * \$	Mini	Up to 0.5 lb	18 Pack	<del>13.60</del>

\* Limited Warranty and Limitation of Liability (for product sold in USA): This product will be free from manufacturing defects. If defective, your exclusive remedy shall be, at 3M's option, product replacement or refund. 3M will not be liable for any loss or damage arising from this product, whether direct, indirect, special, incidental or consequential.

## C DESIGNER HOOKS

Decorative hooks with Command™ adhesive strips hold strongly yet can be removed cleanly with no surface damage.

ID No.	Size	Holds	Qty.	Unit	Price
<b>White Designer Hook</b>					
19	MMM-17083S16NA *	Large	Up to 5 lbs	16 Pack	<del>54.50</del>
20	MMM-17081ES *	Medium	Up to 3 lbs	2 Pack	<del>4.85</del>
21	MMM-170816ES *	Medium	Up to 3 lbs	6 Pack	<del>13.23</del>
<b>White Designer Hook</b> —Cabinet Pack—Individually wrapped hooks with adhesive strips.					
22	MMM-17081CABPK *	Medium	Up to 3 lbs	50 Count	<del>66.50</del>

\* Limited Warranty and Limitation of Liability (for product sold in USA): This product will be free from manufacturing defects. If defective, your exclusive remedy shall be, at 3M's option, product replacement or refund. 3M will not be liable for any loss or damage arising from this product, whether direct, indirect, special, incidental or consequential.

Prices subject to change without notice.  
Visit our website for the latest pricing and product information.

# Office Furnishings Glue & Adhesive/Mounting Products



MMM-17201CABPK



MMM-17024S256NA



## A DECORATIVE HOOKS

Dress up your wall with sleek and stylish hooks. They hold on strongly, and come off cleanly leaving no surface damage.

ID No.	Size	Holds	Qty.	Unit	Price
<b>Brushed Nickel Traditional Design</b>					
1	Large	Up to 5 lbs	3	Pack	<del>8.43</del>
<b>Brushed Nickel</b>					
2	Medium	Up to 3 lb	2	Pack	<del>14.48</del>
<b>Matte Black</b>					
3	Medium	Up to 3 lb	2	Pack	<del>14.48</del>

★ *Limited Warranty and Limitation of Liability (for product sold in USA): This product will be free from manufacturing defects. If defective, your exclusive remedy shall be, at 3M's option, product replacement or refund. 3M will not be liable for any loss or damage arising from this product, whether direct, indirect, special, incidental or consequential.*

## B VARIETY PACKS

An assortment of Command™ Products contained in a reclosable kit for easy storage and organization. Always have the products you need to quickly and easily hang your décor! Best of all, when you are ready to take down or redecorate, they come off cleanly - no nail holes or sticky residue.

ID No.	Size	Holds	Qty.	Unit	Price
<b>Clear Hooks and Strips Variety Pack</b> —Hang up to 19 items. Includes 8 small picture hanging strips, 8 large picture hanging strips, 3 medium clear hooks with 4 strips, 1 large clear hook with 2 strips, 7 small clear hooks with 8 strips and 4 small wire hooks with 8 strips.					
4	Assorted	Up to: Picture Strips: 4-16 lbs; Small Hook: 0.5 lb; Medium Hook: 2 lbs; Large Hook: 4 lbs	53	Pack	<del>27.78</del>
<b>General Purpose Hooks Variety Pack</b> —Hang up to 19 items. Includes 6 small picture hanging strips, 4 large picture hanging strips, 3 medium utility hooks, 2 large utility hooks, 3 small utility hooks, 6 small wire hooks.					
5	Assorted	Up to: Small Strips: 1 lb; Small Utility: 1 lb; Small Wire: 0.5 lb; Medium Utility: 3 lbs; Large Strips: 16 lbs; Large Utility: 5 lbs	54	Pack	<del>27.78</del>

★ *Limited Warranty and Limitation of Liability (for product sold in USA): This product will be free from manufacturing defects. If defective, your exclusive remedy shall be, at 3M's option, product replacement or refund. 3M will not be liable for any loss or damage arising from this product, whether direct, indirect, special, incidental or consequential.*

## C PICTURE HANGING STRIPS

Ideal for hanging pictures without nail holes; interlocking fastener adheres firmly to flat surface. Removes cleanly without surface damage.

ID No.	W × L	Holds	Qty.	Unit	Price
<b>Black</b>					
6	0.75" × 2.75"	Up to 3 lbs per pair	4	Pack	<del>5.90</del>
<b>White</b>					
7	0.75" × 2.75"	Up to 3 lbs per pair	3	Pack	4.75
8	0.75" × 2.75"	Up to 3 lbs per pair	52	Pack	<del>51.78</del>
9	0.63" × 2.13"	Up to 1 lb per pair	4	Pack	4.75
10	0.5" × 3.63"	Up to 4 lbs per pair	4	Pack	<del>6.40</del>
<b>White—Cabinet Pack</b> —Individually wrapped packs of four strips.					
11	0.75" × 2.75"	Up to 3 lbs per pair	50	Pack	<del>80.00</del>

## D PICTURE HANGING KIT

Kit contains an assortment of Command™ picture hanging products in a re-closable kit for easy storage and organization. Handy strips ensure damage-free hanging. They hold on strongly, keeping your artwork right where you want it. Best of all, when you are ready to take down or move your pictures, they come off cleanly—no nail holes or sticky residue.

ID No.	Size	Holds	Qty.	Unit	Price
<b>Hangs up to 15 Pictures</b> — Includes 3 sawtooth picture hangers, 2 wire back picture hangers, 5 large strips, 4 pairs of large picture hanging strips, 8 pairs of small picture hanging strips and 16 poster strips.					
12	Assorted	Up to: Sawtooth: 4 lbs; Small: 4 lbs; Large: 16 lbs; Wire Hanger: 5 lbs	1	Kit	<del>27.30</del>
<b>Hangs up to 7 Pictures</b> —Includes 4 Pair Small Picture Hanging Strips, 4 Pair Large Picture Hanging Strips, 2 Large Strips, 4 Poster Strips, 2 Sawtooth Hangers.					
13	Assorted	Up to: Sawtooth: 4 lbs; Small: 1 lb; Large: 16 lbs	24	Pack	<del>14.25</del>

★ *Limited Warranty and Limitation of Liability (for product sold in USA): This product will be free from manufacturing defects. If defective, your exclusive remedy shall be, at 3M's option, product replacement or refund. 3M will not be liable for any loss or damage arising from this product, whether direct, indirect, special, incidental or consequential.*

## E POSTER STRIPS

Use these adhesive mounting strips to secure calendars and other flexible objects to walls. There's no sagging or falling; strips hold firmly, yet remove cleanly.

ID No.	W × L	Holds	Qty.	Unit	Price
<b>White</b>					
14	0.63" × 1.75"	Up to 1 lb per pair	12	Pack	<del>3.00</del>
15	0.63" × 1.75"	Up to 1 lb per pair	256	Pack	<del>51.78</del>
<b>White—Cabinet Pack</b> —Individually wrapped packs of 4 strips.					
16	0.63" × 1.75"	Up to 1 lb per pair	100	Pack	<del>80.00</del>
<b>White—Value Pack - Stock up and save!</b>					
17	0.63" × 1.75"	Up to 1 lb per pair	48	Pack	<del>10.90</del>

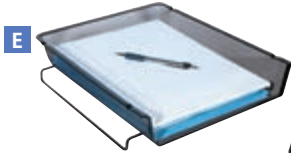
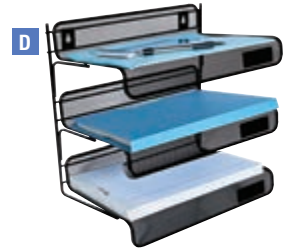
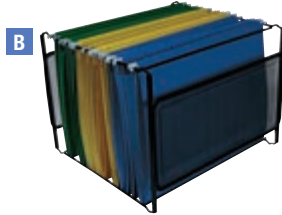
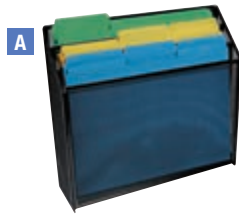

## universal.

### A MESH THREE-TIER ORGANIZER

Tiered design takes up a fraction of desk space as traditional organizers. Three compartments provide sorting options. Slanted design allows for instant identification of important documents. Sits firmly on desk and will not fall over even when full. Manufacturer's limited one-year warranty.

ID No.	Size	Tiers	Color	Unit	Price
1 UNV-20007	Letter	3	Black	Each	54.73

### B MESH FILE FRAME HOLDER

Organizes and stores your files. Freestanding design—can be placed on a desk or on the floor out of the way. Can be used to retrofit drawers for filing. Mesh construction makes files easily visible. Accommodates standard letter size hanging files. [✕](#)

ID No.	Color	Size	W × D × H	Unit	Price
2 UNV-20003	Black	Letter	11¼" × 12¾" × 9¼"	Each	20.96

### C MESH STACKING SORTER

Five sections for sorting file folders, books, papers, and more. Manufacturer's limited one-year warranty.

ID No.	Size	Tiers	Color	Unit	Price
3 UNV-20001	Legal; Letter	5	Black	Each	38.01

### D MESH THREE-TIER DESK SHELF

Desk shelf has three levels for organizing papers. Shelf can be mounted on partition/walls or placed on a desk for easy access. Area for labels on each shelf for quick identification (labels not included). Manufacturer's limited one-year warranty.

ID No.	Size	Tiers	Color	Unit	Price
4 UNV-20006	Letter/A4	3	Black	Each	33.32

### E MESH STACKABLE FRONT LOAD TRAY

Tray keeps papers organized. Stackable to maximize desktop space. Interlocking feet ensure secure stacking of up to five trays. Manufacturer's limited one-year warranty.

ID No.	Size	Tiers	Color	Unit	Price
5 UNV-20004	Letter/A4	1	Black	Each	18.10

### F MESH STACKING SIDE LOAD TRAY

Tray keeps papers organized. Stackable to maximize desktop space. Interlocking feet ensure secure stacking of up to five trays. Manufacturer's limited one-year warranty.

ID No.	Size	Tiers	Color	Unit	Price
6 UNV-20012	Legal	1	Black	Each	24.40

### G MESH WASTEBASKET

Keeps workspaces neat and tidy. Stylish mesh design looks great while keeping trash in its place. Manufacturer's limited one-year warranty.

ID No.	Capacity	Dia. × H	Color	Unit	Price
7 UNV-20008	18 qt	11¾" × 14¼"	Black	Each	38.48

### H MESH TELEPHONE DESK STAND

Supports all phone sizes and styles. Elevates phone from workspace with extra room below for storage. Includes side pocket for messages, notes, pens or pencils. Non-skid feet won't scratch desktop.

ID No.	W × D × H	Color	Unit	Price
8 UNV-20015	11¼" × 10¼" × 5¼"	Black	Each	25.07

### I MESH THREE-PACK WALL FILES

Keep important documents and files organized and at hand. Versatile design can be used one, two or three at a time. Mount on partition with unique hanging system (included). Contemporary style works with any office environment. [✕](#)

ID No.	Pocket(s)	Size	Color	Unit	Price
9 UNV-20011	3	Letter	Black	Set	58.12

### J METAL MESH DESKTOP MONITOR STAND WITH DRAWER

Raise your monitor to eye level while increasing your usable workspace. Two side compartments and a pull out drawer to hold all your office supplies. Durable metal mesh construction is both strong and stable to withstand years of use.

ID No.	W × D × H	Color	Unit	Price
10 UNV-20018	18" × 11¼" × 5½"	Black	Each	58.06

### K METAL MESH DRAWER ORGANIZER

Deep multi-compartment organizer provides extra capacity to keep everything in its place in your drawer and easy to find. Perfectly sized to fit most common drawer sizes in file cabinets or pedestals. Two extra-long compartments for rulers, writing instruments, scissors, and sticky notes. Four smaller compartments to hold everyday office supplies including one plastic insert cup for tacks and pins. Durable metal mesh construction is both strong and stable to withstand years of use.

ID No.	Compartments	W × D × H	Color	Unit	Price
11 UNV-20021	6	15" × 11¾" × 2½"	Black	Each	35.54

Prices subject to change without notice.

Visit our website for the latest pricing and product information.

# Office Furnishings Desk Accessories



universal.

## A MESH JUMBO PENCIL CUP

Jumbo pencil cup organizes all your writing instruments in one place. Pencil cup can also be used to store scissors, rulers and other tall desk accessories.

ID No.	Color	Dia. × H	Unit	Price
1 UNV-20013	Black	4 3/4" × 5 3/4"	Each	10.53

## B MESH DESK ORGANIZER

Puts desk essentials in their proper place. Features two compartments for pens and pencils. Includes two side dividers for pads and a space for a 3" × 3" note pad. Manufacturer's limited one-year warranty.

ID No.	Compartments	Color	W × D × H	Unit	Price
2 UNV-20002	4	Black	5 3/4" × 5 3/4" × 4 1/4"	Each	20.72

## C MESH JUMBO STORAGE DISH

Allows you to contain all your frequently used desk supplies like paper clips, binder clips, push pins and more. Large capacity means you never run out. Mesh design allows for easy identification of the contents. Manufacturer's limited one-year warranty.

ID No.	Compartments	Color	Dia. × Height	Unit	Price
3 UNV-20014	1	Black	4 3/4" × 2"	Each	6.22

## D MESH BUSINESS CARD HOLDER

Simple, clean mesh design goes with any office. Keep business cards handy and ready to give out. Open design allows easy browsing.

ID No.	For Card Size	Card Capacity	W × D × H	Color	Unit	Price
4 UNV-20005	2 1/4" × 4"	50	3 3/8" × 3 3/8" × 2 1/8"	Black	Each	5.93

## E METAL MESH ORGANIZER TRAY

Keep everyday office supplies handy and organized on your desk or in your drawer. One long compartment for writing instruments and three small compartments, including one plastic insert cup for tacks and pins. Durable metal mesh construction is both strong and stable to withstand years of use. Rubber pads to prevent scratches.

ID No.	Compartments	W × D × H	Color	Unit	Price
5 UNV-20020	4	10 3/4" × 6" × 2"	Black	Each	22.98

## F METAL MESH 3-COMPARTMENT PENCIL CUP

Three compartments to sort your writing instruments, rulers, scissors and office supplies. Angled opening to conveniently access both short and tall supplies. Durable metal mesh construction is both strong and stable to withstand years of use.

ID No.	Compartments	Color	W × D × H	Unit	Price
6 UNV-20019	3	Black	4" × 4" × 6"	Each	12.33

## G METAL MESH OVAL DESKTOP ORGANIZER

Convenient multi-compartment desktop organizer to store all your everyday office supplies. Drawer can accommodate standard sticky-notes. Shallow and deep compartments to hold pens, clips, scissors, or erasers. Durable metal mesh construction is both strong and stable to withstand years of use. Manufacturer's limited one-year warranty.

ID No.	Compartments	Color	W × D × H	Unit	Price
7 UNV-20023	8	Black	9 3/4" × 4" × 4 1/4"	Each	21.88

## H METAL MESH ROTATING DESKTOP ORGANIZER

Spins for easy access to all your office supplies. Convenient multi-compartment organization to sort pens, pencils, rulers, scissors, and low compartments for small items. Rubber padded for a good grip when rotating. Durable metal mesh construction is both strong and stable to withstand years of use. Manufacturer's limited one-year warranty.

ID No.	Compartments	Color	W × D × H	Unit	Price
8 UNV-20022	8	Black	6 1/2" × 6 1/2" × 6 1/2"	Each	14.29

## I METAL MESH TIERED FILE SORTER

Keep all your everyday files organized and available at a glance. Tiered sections for improved visibility and access. Durable metal mesh construction is both strong and stable to withstand years of use. Padded to prevent scratches. Manufacturer's limited one-year warranty.

ID No.	Tiers	Color	Unit	Price
9 UNV-20024	5	Black	Each	48.39

## J METAL MESH WALL FILE

Add convenient file storage and organization to any wall. Stack multiple units to create a wall file system for quick sorting. Full metal back ensures no paper can slip through. Mounting hardware included. Durable metal mesh construction is both strong and stable to withstand years of use.

ID No.	Pocket(s)	Size	Color	Unit	Price
10 UNV-20026	1	Letter	Black	Each	20.56

## K METAL MESH DOCUMENT HOLDER

Keep your current document handy and at an easy glance. Holds paper up to letter size and most books. Includes two magnets to secure up to 35 paper or memo sheets. Durable metal mesh construction is both strong and stable to withstand years of use. Manufacturer's limited one-year warranty.

ID No.	Size	Color	Unit	Price
11 UNV-20027	9"w × 8"d × 11 1/2"h	Black	Each	13.00





## universal.

### A – C RECYCLED PLASTIC DESK ACCESSORIES

Stylish, simple and smart. Keep it coordinated with sturdy, recycled-plastic desk accessories.

#### A RECYCLED PLASTIC SIDE LOAD DESK TRAYS

Self-stacking. 2¾" high. Two trays per pack. Manufacturer's limited one-year warranty. ♻️ 🌱 🌿

ID No.	Size	Tiers	Color	Unit	Price
1 UNV-08101 ★	Legal	2	Black	Pack	17.10
2 UNV-08100 ★	Letter/A4	2	Black	Pack	8.26

★ Contains 30% post-consumer recycled content, 30% total recycled content.

#### B RECYCLED PLASTIC INCLINE SORTER

Graduated tiers keep files visible and within easy reach. Manufacturer's limited one-year warranty. ♻️ 🌱 🌿

ID No.	Size	Tiers	Color	Unit	Price
--------	------	-------	-------	------	-------

**Large Sorter**—Holds file folders, notepads and more.

3 UNV-08105 ★	Letter	5	Black	Each	27.26
---------------	--------	---	-------	------	-------

**Mini Sorter**—Perfect for sorting envelopes, memos and bills.

4 UNV-08104 ★	Letter	5	Black	Each	15.17
---------------	--------	---	-------	------	-------

★ Contains 30% post-consumer recycled content, 30% total recycled content.

#### C LARGE STANDARD SORTER

Extra-wide sections create a big filing capacity. Stacks directly on top of Universal® letter-size desk tray, sold separately. Durable plastic. Manufacturer's limited one-year warranty. ♻️ 🌱 🌿

ID No.	Size	Tiers	Color	Unit	Price
5 UNV-08125 ★	Letter	5	Black	Each	15.54

★ Contains 30% post-consumer recycled content.

#### D ROTARY ORGANIZER

Keep all your supplies close at hand! Efficient organizer has compartments to hold pens, pencils, scissors, paperclips and much more. Easily rotates for quick access. Manufacturer's limited one-year warranty. ♻️ 🌱 🌿

ID No.	Compartments	Color	Dia. × Height	Unit	Price
6 UNV-08151 ★	11	Black	8¼" × 5"	Each	17.65

★ Contains 30% post-consumer recycled content.

### E – I RECYCLED PLASTIC DESK ACCESSORIES

Stylish, simple and smart. Keep it coordinated with sturdy, recycled-plastic desk accessories.

#### E RECYCLED PLASTIC MAGAZINE FILE

Use to organize magazines, files, brochures and more. Perfect for home, office or reception area. Sturdy plastic. ♻️ 🌱 🌿

ID No.	Color	W × D × H	Qty.	Unit	Price
7 UNV-08118 ★	Black	3" × 10" × 11½"	1	Each	5.92

★ Contains 30% post-consumer recycled content, 30% total recycled content.

#### F RECYCLED PLASTIC LARGE MAGAZINE FILE

Keeps magazines, catalogs and other literature neat and easily accessible. ♻️ 🌱 🌿

ID No.	Color	W × D × H	Qty.	Unit	Price
8 UNV-08119 ★	Black	6¼" × 10" × 11½"	1	Each	9.18

★ Contains 30% post-consumer recycled content, 30% total recycled content.

#### G RECYCLED EXTRA CAPACITY DESKTOP FILE HOLDER

Conveniently store, view and retrieve files. Includes step-up inserts for tiered filing. Sturdy plastic. ♻️ 🌱 🌿

ID No.	Color	Size	W × D × H	Unit	Price
9 UNV-08123 ★	Black	Letter	13¼" × 8½" × 9½"	Each	23.26

★ Contains a minimum of 30% post-consumer recycled content, 100% total recycled content.

#### H RECYCLED PLASTIC DELUXE DESK ORGANIZER

Keeps essentials in one handy place. Large space for pens and pencils, plus room for clips, sticky notes, envelopes and more. Manufacturer's limited one-year warranty. ♻️ 🌱 🌿

ID No.	Compartments	Color	W × D × H	Unit	Price
10 UNV-08110 ★	6	Black	5½" × 6¾" × 5"	Each	11.84

★ Contains 30% post-consumer recycled content, 30% total recycled content.

#### I RECYCLED PLASTIC BIG PENCIL CUP

Pencil holder features three separate stepped compartments to hold all your writing tools. ♻️ 🌱 🌿

ID No.	Compartments	Color	Dia. × H	Unit	Price
11 UNV-08108 ★	3	Black	4¾" × 5½"	Each	7.26

★ Contains 30% post-consumer recycled content, 30% total recycled content.

# Office Furnishings Desk Accessories

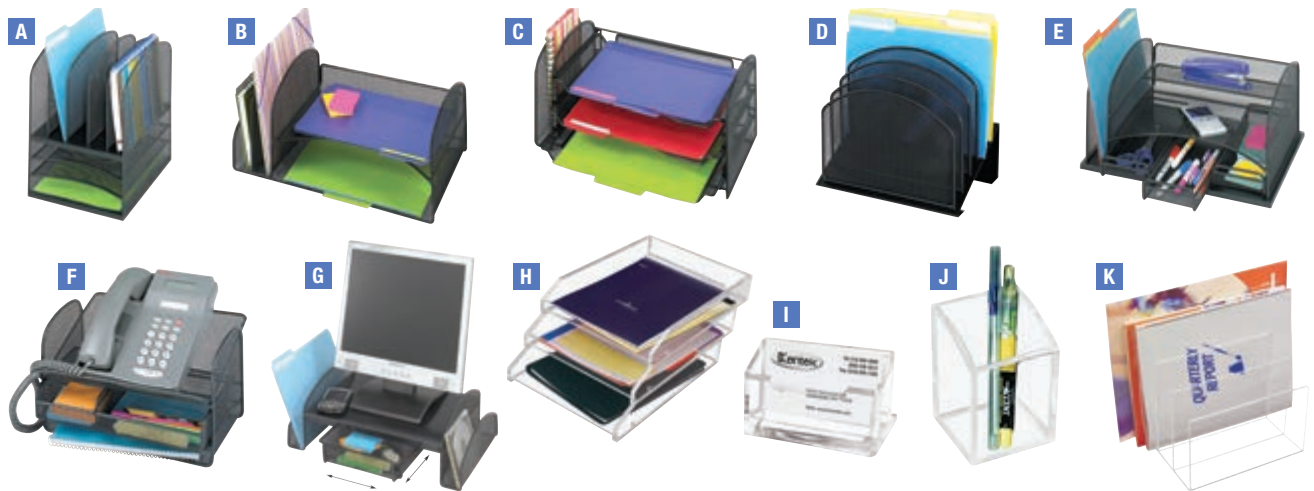

## A ONYX™ MESH DESK ORGANIZER WITH FIVE VERTICAL/THREE HORIZONTAL SECTIONS

Attractive, sturdy mesh organizer is a multi-functional desktop accessory. Five 1" wide vertical sections hold file folders, slim binders, books or magazines. Three 1" horizontal sections accommodate any letter-size document and supplies. Steel mesh construction with powder coat finish for durability. Manufacturer's limited lifetime warranty.

ID No.	Size	Tiers	Color	Unit	Price
1 SAF-3266BL *	Letter	8	Black	Each	72.00
2 SAF-3266WH *	Letter	8	White	Each	72.00

\* GREENGUARD Certified.

## B ONYX™ MESH DESK ORGANIZER WITH TWO VERTICAL/TWO HORIZONTAL SECTIONS

Organizer helps maximize desktop space. Features two vertical sections that can hold file folders and binders and two horizontal sections that can accommodate any letter size documents. Bottom shelf also accommodates the mesh drawer organizer (3262BL), sold separately. Durable steel mesh construction.

ID No.	Compartments	Color	W × D × H	Unit	Price
3 SAF-3264BL *	4	Black	17" × 10¾" × 7¾"	Each	52.00

\* GREENGUARD Certified.

## C ONYX™ MESH DESK ORGANIZER WITH ONE VERTICAL/THREE HORIZONTAL SECTIONS

Upright section holds file folders and small binders. Sliding trays hold letter-size documents. Bottom tray may be removed and replaced with mesh drawer organizer (3262BL), sold separately. Steel mesh construction.

ID No.	Compartments	Color	W × D × H	Unit	Price
4 SAF-3265BL *	4	Black	16¾" × 9" × 8"	Each	63.00

\* GREENGUARD Certified.

## D ONYX™ MESH DESK ORGANIZER WITH TIERED SECTIONS

Tiered design saves desktop space and allows easier access. 1" wide sections for file folders or small binders. Steel mesh construction with powder coat finish for durability.

ID No.	Size	Tiers	Color	Unit	Price
5 SAF-3258BL *	Letter; Legal	8	Black	Each	68.00
6 SAF-3258WH *	Letter; Legal	8	White	Each	68.00
7 SAF-3257BL *	Letter; Legal	5	Black	Each	55.00

\* GREENGUARD Certified.

## E ONYX™ ORGANIZER WITH THREE DRAWERS

Store folders, pads, scissors, pens and more, all in one well-designed organizer. Features one 2" section for a binder or folders, two trays and three drawers. Steel mesh construction. Manufacturer's limited lifetime warranty.

ID No.	Compartments	Color	W × D × H	Unit	Price
8 SAF-3252BL *	6	Black	16" × 11½" × 8¼"	Each	66.00

\* GREENGUARD Certified.

## F ONYX™ MESH TELEPHONE STAND

Angled platform holds phone at just the right degree for quick and easy dialing and pickup. Versatile storage drawer has adjustable, removable divider. Additional storage underneath stand can be used for phone books, notebooks, files, binders or papers. Steel mesh design with durable, black powder coat finish.

ID No.	W × D × H	Color	Unit	Price
9 SAF-2160BL *	11¾" × 9¼" × 7"	Black	Each	40.00

\* GREENGUARD Certified.

## G ONYX™ MESH MONITOR STAND

Helps reduce neck and eye strain by raising monitor 4" for more comfortable viewing. Two side compartments and a sliding, pullout drawer add convenient space-saving storage for supplies. Durable steel mesh construction provides strength and stability.

ID No.	W × D × H	Color	Unit	Price
10 SAF-2159BL *	19¾" × 11¼" × 6¼"	Black	Each	70.00

\* GREENGUARD Certified.



## H – K CLEAR ACRYLIC DESK ACCESSORIES

Heavy cast clear acrylic combines elegance and durability. Nonskid feet.

### H CLEAR ACRYLIC LETTER TRAY

Elegance and durability. Nonskid feet protect desk. Can be used separately or stacked in straight or terraced position. Each tray measures 10¾"W × 13¾"D × 2¾"H.

ID No.	Size	Tiers	Color	Unit	Price
11 KTK-AD-15	Letter/A4	2	Clear	Each	56.99
12 KTK-AD-10	Letter/A4	1	Clear	Each	31.99

### I CLEAR ACRYLIC BUSINESS CARD HOLDER

Angled design for durability and a sleek, contemporary look. Manufacturer's one-year limited warranty.

ID No.	For Card Size	Card Capacity	W × D × H	Color	Unit	Price
13 KTK-AD-30	Business Card	80	4" × 1¾" × 2"	Clear	Each	7.00

### J PENCIL CUP

Elegance and durability in heavy cast acrylic. Keeps your writing instruments in sight and within reach.

ID No.	Finish	W × D × H	Unit	Price
14 KTK-AD-20	Clear	2¾" × 2¾" × 4"	Each	11.99

### K CLEAR ACRYLIC DESK FILE

Stylish, durable sorter. 2" sections store folders and files. Nonskid feet.

ID No.	Tiers	Color	Unit	Price
15 KTK-AD-45	3	Clear	Each	38.97

## Artistic®

### A WIRELESS CHARGING PADS

Charge mobile phone wirelessly with our Qi-Certified Wireless Charging Pad. Plug the provided micro-USB cable into any USB power source and power away. Compatible with iPhone 8/8 Plus, iPhone X, Samsung 6/6 Plus and later models. Pad can be used completely flat or fold the panel up for an angled view. Features a smooth writing surface. Made of leather-like material.

ID No.	Port/Amps	Cable Type	Unit	Price
1 AOP-ART59026M	One 1.0 Amp Port	Detachable USB to Micro USB Cable (Included)	Each	34.99
2 AOP-ART59026D9	One 1.0 Amp Port	Detachable USB to Micro USB Cable (Included)	Each	54.99
3 AOP-ART59026D0	One 1.0 Amp Port	Detachable USB to Micro USB Cable (Included)	Each	74.99

### B MONTICELLO DESK PAD

Features an ultra-high-grade leather-like material with a smooth writing surface for improved penmanship. Fold-out side panels on left and right sides for business cards. Soft, scratch-resistant backing. Sophisticated black and charcoal grey color scheme. Provides a non-glare, anti-skid, anti-static dust-repelling surface. Ideal for home office or office areas.

ID No.	Size	Color	Unit	Price
4 AOP-5240BG	24" × 19"	Black/Grey	Each	67.79

### C LIFT-TOP PAD™ DESKTOP ORGANIZER

Cushioned writing surface for comfort. Clear overlay keeps papers in view. Metric and English rulers on overlay. Nonslip rubber base keeps desk pad in place.

ID No.	Size	Color	Unit	Price
5 AOP-41700S	22" × 17"	Black	Each	34.99
6 AOP-41100S	24" × 19"	Black	Each	39.99
7 AOP-41200S	31" × 20"	Black	Each	49.99

### D SECOND SIGHT CLEAR PLASTIC DESK PROTECTOR

Crystal clear micro-thin flexible plastic protects and provides view of important papers underneath.

ID No.	Size	Color	Unit	Price
<b>Hinged Protector</b> —Adhesive strip at top acts as a hinge to prevent shifting while allowing access to papers underneath. Static cling keeps document in place.				
8 AOP-SS1721	21" × 17"	Clear	Each	14.49
9 AOP-SS2125	25½" × 21"	Clear	Each	19.49
<b>Multipurpose Protector</b> —Trimnable for versatility. Can also be used as a blotter protector or surface for dry erase markers.				
10 AOP-SS1924	24" × 19"	Clear	Each	3.65
11 AOP-SS2036	36" × 20"	Clear	Each	6.15

### E KRYSTALVIEW™ DESK PAD WITH ANTIMICROBIAL PROTECTION

See-through desk pad keeps important information, such as lists, charts and schedules in view. Flexible vinyl bends for insertion of materials. Cushioned writing surface for smooth handwriting. Not recommended for use on lacquer, acrylic or urethane finishes. Infused with antimicrobial product protection.

ID No.	Size	Color	Unit	Price
<b>Glossy Finish</b> —Clear surface for ultimate clarity.				
12 AOP-60-7-OMS	22" × 17"	Clear	Each	36.22
13 AOP-60-4-OMS	24" × 19"	Clear	Each	43.61
14 AOP-60-6-OMS	36" × 20"	Clear	Each	54.30
15 AOP-60-8-OMS	38" × 24"	Clear	Each	59.95
<b>Matte Finish</b> —Nonglare surface helps reduce eyestrain.				
16 AOP-60740MS	17" × 12"	Clear	Each	25.53
17 AOP-60240MS	22" × 17"	Clear	Each	36.22
18 AOP-60440MS	24" × 19"	Clear	Each	43.61
19 AOP-60640MS	36" × 20"	Clear	Each	54.30

### F EXECUTIVE DESK PAD WITH ANTIMICROBIAL PROTECTION

Ergonomic desk pad enables smoother writing, while the handsome leather-like side panels provide space for cards, notes and memos. Surface infused with antimicrobial product protection. Writing surface made from recyclable material.

ID No.	Size	Color	Unit	Price
20 AOP-4138-4-1	24" × 19"	Black	Each	32.49
21 AOP-4138-6-1	36" × 20"	Black	Each	44.49

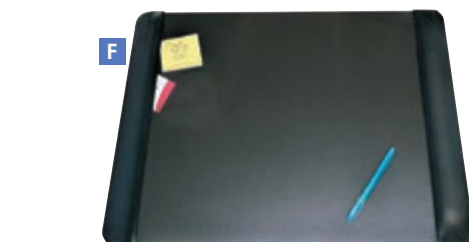
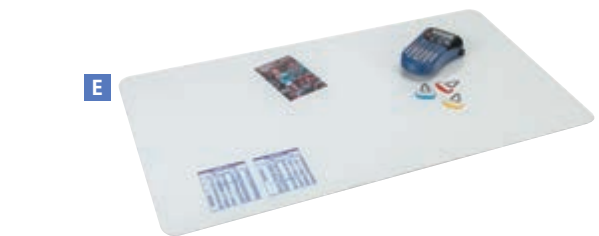

# Office Furnishings Fans



## A 12" 3-SPEED OSCILLATING DESK FAN

Oscillating fan provides smooth cooling air-flow. 12" diameter fan blades provide ample air circulation and minimal noise. Features three-speed settings, oscillation on/off control and vertical tilt adjustability. 80° oscillation for wide area coverage. Manufacturer's limited one-year warranty.

ID No.	Color	W × D × H	Unit	Price
1 ALE-FAN122W *	White	13% × 10% × 19"	Each	44.00
2 ALE-FAN122B *	Black	13% × 10% × 19"	Each	44.00

\* ETL Certified.

## B 16" WALL MOUNT FAN

Oscillating wall mount fan is ideal when you need something up and out-of-the-way off the floor. Large coverage area with a 80-degree tilt gets air flowing in most medium to large size room. Easy to mount with included hardware. 5 ft. power cord. Long pull cords allow for easy adjustment of speed or oscillation even when mounted high up. Includes knob controls. Three speed settings. Sturdy metal frame with transparent fan blades. Manufacturer's limited one-year warranty.

ID No.	Color	W × D × H	Unit	Price
3 ALE-FANWM16W *	White	18" × 13" × 22"	Each	55.00

\* ETL Certified.

## C 16" 3-SPEED OSCILLATING PEDESTAL FAN

Height adjustable stand (42" to 49") gets air where you need it most. Tilting and oscillating functions circulate air effectively in most medium and large rooms. 3-speed settings for low, medium or high fan speeds. Carry handle to easily reposition. Wide disk base for solid stability. Manufacturer's limited one-year warranty. ♻️ ♻️ ♻️

ID No.	Color	W × D × H	Unit	Price
4 ALE-FANP16B *	Black	26% × 26% × 41% to 49¼"	Each	83.00
5 ALE-FANP16W *	White	26% × 26% × 41% to 49¼"	Each	83.00

\* ETL Certified. Contains 30% post-consumer recycled content, 30% total recycled content.

## Holmes

### D 16" WALL MOUNT FAN

This 16" oscillating wall-mount fan is a real problem solver. Easy to assemble and can be quickly installed with the included mounting hardware. Can be controlled by either the rotary knob or the three-way pull cord. Features a sturdy metal frame. Manufacturer's limited three-year warranty. ♻️

ID No.	Color	W × D × H	Unit	Price
6 HLS-HMF1611A-UM	Black	19% × 9% × 16%"	Each	64.99

## Lakewood

### E 16" REMOTE CONTROL STAND FAN

Features remote control operation and front-mounted control panel. Three speed settings and oscillation for wide area coverage make this ideal for medium and large rooms. Tilt-adjustable head and height-adjustable pole. Carry handle for easy portability. Automatic shut-off timer. Sleep/breeze mode. Manufacturer's limited three-year warranty. ♻️

ID No.	Color	W × D × H	Unit	Price
7 LAK-LSF1610BR-BM	Black	18" × 18" × 42"	Each	84.99



## Honeywell

### F QUIETSET™ 8-SPEED WHOLE-ROOM TOWER FAN

Powerful, quiet, whole room cooling. Eight levels of quiet control, from "white noise" to "whisper." Features digital temperature display, adjustable thermostat, oscillation, remote control and breeze mode. 12-hour auto shut-off timer. Reach through carrying handle. Manufacturer's limited one-year warranty. ♻️

ID No.	Color	W × D × H	Unit	Price
8 HWL-HYF290B *	Black	10" × 10" × 40"	Each	152.17

\* ETL Listed.

## BIONAIRE

### G REMOTE CONTROL TOWER FAN

Sleek tower design offers an innovative space saving solution to fulfill your cooling needs. The fan tilts back on a slope to circulate air in the entire room. Remote control for convenient operation. Multiple speed settings. Oscillation for wide area coverage. Features automatic shut-off timer, sleep/breeze settings and remote control storage. LED control panel with visual indicators. Manufacturer's limited five-year warranty.

ID No.	Color	W × D × H	Unit	Price
9 BNR-BTF4011AR-BU *	Black/Silver	12% × 12% × 40"	Each	164.99

\* ETL Listed.

### H PERSONAL SPACE MINI TOWER FAN

Slim, space-saving design and quiet operation are ideal for personal space cooling. Two speed settings. Oscillation for wide area coverage. Top mounted push-button control interface. Metallic accented housing. Integrated carry handle for easy portability. Manufacturer's limited three-year warranty.

ID No.	Color	W × D × H	Unit	Price
10 BNR-BT014AU	Black/Silver	7" × 6% × 13¼"	Each	54.99



### I 28" 3-SPEED TOWER FAN

Clever and quiet tower design makes the most of tight spaces. 60 degree oscillation circulates cool air throughout the whole room. Features three-speed settings, oscillation on/off control, and integrated carry handle. Manufacturer's limited one-year warranty. ♻️

ID No.	Color	W × D × H	Unit	Price
11 ALE-FAN283 *	Black	9.61" × 9.61" × 27.95"	Each	87.00

\* UL Certified.

## Holmes

### J 3 SPEED OSCILLATING TOWER FAN WITH REMOTE CONTROL

Cools any—and every—part of a room. Three speed settings make it easy to cool the room to just the right temperature. Features oscillation for wide-area coverage, top-mounted electronic LED control panel and timer. Integrated carry handle and lightweight for easy portability. Manufacturer's limited three-year warranty.

ID No.	Color	W × D × H	Unit	Price
12 HLS-HT38RB-U *	Metallic Silver/Black	9% × 9% × 36"	Each	99.00

\* ETL Certified.





**Holmes.**

**A 4" MINI HIGH VELOCITY PERSONAL FAN**

Features 4" metal blade diameter. Tilt adjustable head allows you to focus air flow where you need it. Metal front and rear grilles. Perfect for use on a table or desk in the office or home. Manufacturer's limited one-year warranty.

ID No.	Color	W x D x H	Unit	Price
1	Black	6" x 4" x 6"	Each	24.99

**B 6" CONVERTIBLE CLIP/DESK FAN**

Cool your personal space with this versatile, convertible fan. Durable grip clip secures fan to tables, desks, shelves and countertops. Or affix to base attachment for desk or tabletop. Two speed settings offer added control. Tilt-adjustable head. Manufacturer's limited one-year warranty.

ID No.	Color	W x D x H	Unit	Price
2	White	7 7/8" x 8 3/4" x 12 3/4"	Each	26.99

**C 12" OSCILLATING FLOOR FAN**

Stay cool with this fan's unique oscillating directional grille. Includes remote control for convenient operation and an eight-hour automatic shut-off timer and sleep/breeze modes. Three speed settings and an oversized carry handle for easy portability. Cord storage included. Manufacturer's three-year warranty.

ID No.	Color	W x D x H	Unit	Price
3	Black	20 1/4" x 7 3/4" x 18 1/4"	Each	84.00

**Honeywell**

**D SUPER TURBO™ HIGH PERFORMANCE FAN**

Versatile aerodynamic wind tunnel design provides fast, focused cooling. Powerful three-speed motor with high, medium and low operation options. Variable tilt head pivots 90° for use as an air circulator. Can be wall mounted. Manufacturer's limited one-year warranty.

ID No.	Color	W x D x H	Unit	Price
4	Black	11" x 6 1/2" x 11 3/4"	Each	25.44

★ UL Listed.

**PATTON**

**E HIGH-VELOCITY FAN**

Powerful motor with large blade diameter designed to move lots of air. Metal construction built tough to withstand harsh environments. Three speed settings. Tilt adjustable head allows you to focus airflow where you need it. Powder coated finish and rear mounted carry handle for easy portability. Manufacturer's limited five-year parts/labor warranty. ✕

ID No.	Color	W x D x H	Unit	Price
5	Black	24 1/2" x 8 3/4" x 22 7/8"	Each	130.50

**ALERA.**

**F 36" 3-SPEED OSCILLATING TOWER FAN WITH REMOTE CONTROL**

Clever and quiet tower design makes the most of tight spaces. 60° oscillation circulates cool air throughout the whole room. Features three-speed settings, oscillation on/off control, wind modes, and seven-hour automatic shut-off timer. Multi-function remote control and LED display for added convenience. Manufacturer's limited one-year warranty.

ID No.	Color	W x D x H	Unit	Price
6	Black	11 7/8" x 11 7/8" x 36"	Each	115.00

★ ETL Certified.

**G 16" SUPER-CIRCULATION 3-SPEED TILT FAN**

Large 16" diameter blades quickly cool down your space. Clever wind-tunnel style design with five fan blades provides quiet, smooth air-flow to keep air circulating. Durable construction and high-velocity are ideal for large spaces, offices, workshops, or garages. Features three speed settings and full 360 degree tilt fan head. Manufacturer's limited one-year warranty. ✕

ID No.	Color	W x D x H	Unit	Price
7	Black	20 1/2" x 6 1/2" x 19 1/4"	Each	50.00

★ ETL Certified.

**H 3-SPEED BOX FAN**

Large five-blade design pushes a large flow of air out to keep things cool. Slim-profile box fan takes up less space than conventional designs. Lightweight but stable base design ensures it is easy to setup anywhere. Features three-speed settings and a convenient integrated carry-handle. Large rotary knob for easy adjustments. Manufacturer's limited one-year warranty.

ID No.	Color	W x D x H	Unit	Price
8	Black	20 1/2" x 4 1/2" x 21"	Each	44.00

★ ETL Certified.

**I 20" SUPER-CIRCULATOR 3-SPEED TILT FAN**

Large 20" diameter 5-blade fan quickly cools down your space. Wind-tunnel style design which provides quiet, smooth air-flow to keep air circulating. Dual use either on the floor or wall-mountable. Tilts 220 degrees to move air in any direction. Points air up or down whether on the floor or hanging on the wall. Light-weight design for portability and easy hanging. Durable construction and high-velocity are ideal for large spaces, offices, workshops or garages. Features three-speed settings. Integrated carry handle.

ID No.	Color	W x D x H	Unit	Price
9	Black	5.98" x 24.09" x 24.17"	Each	83.00

**J 9" 3-SPEED DESKTOP BOX FAN**

Modern box fan design provides consistent smooth-flow air circulation. 3-speed rotary dial to control air flow. Rubber foot glides for enhanced stability and vibration dampening on most surfaces.

ID No.	Color	W x D x H	Unit	Price
10	White	10.91" x 4.33" x 11.02"	Each	44.00

Prices subject to change without notice. Visit our website for the latest pricing and product information.

# Office Furnishings File Folders/Hanging



## A COLORED HANGING FILE FOLDERS

Hanging folders keep papers neatly vertical in their files. No more slumping folders or folders that slip under one another. Vivid colors help you code files for quick, easy identification. The poly tabs are all clear with a white insert. This product was made using wood sourced from a certified managed forest. ♻️

ID No.	Size	Color	Tab	Qty.	Unit	Price
1 SMD-64062	Letter	Black	1/2-Cut	25	Box	37.55
2 SMD-64060	Letter	Blue	1/2-Cut	25	Box	37.55
3 SMD-64061	Letter	Green	1/2-Cut	25	Box	37.55
4 SMD-64064	Letter	Lavender	1/2-Cut	25	Box	37.55
5 SMD-64073	Letter	Maroon	1/2-Cut	25	Box	37.55
6 SMD-64057	Letter	Navy	1/2-Cut	25	Box	37.55
7 SMD-64065	Letter	Orange	1/2-Cut	25	Box	37.55
8 SMD-64066	Letter	Pink	1/2-Cut	25	Box	37.55
9 SMD-64072	Letter	Purple	1/2-Cut	25	Box	37.55
10 SMD-64067	Letter	Red	1/2-Cut	25	Box	37.55
11 SMD-64074	Letter	Teal	1/2-Cut	25	Box	37.55
12 SMD-64069	Letter	Yellow	1/2-Cut	25	Box	37.55
13 SMD-64056	Letter	Assorted	1/2-Cut	25	Box	41.60
14 SMD-64059	Letter	Assorted	1/2-Cut	25	Box	41.60
15 SMD-64159	Legal	Assorted	1/2-Cut	25	Box	50.10

★ Paper contains 10% post-consumer recycled content, 10% total recycled content.  
SMD-64056—Gray; Maroon; Navy; Purple; Teal. SMD-64059, SMD-64159—Blue; Green; Orange; Red; Yellow.



## B COLOR HANGING FOLDERS WITH 1/2 CUT TABS

These colored hanging folders feature larger 1/2-cut tabs that allow you to write or use more lines of text, so you can quickly find the file you are looking for. Use with colored interior folders to prevent misfiling. This product was made using wood sourced from a certified managed forest. ♻️

ID No.	Size	Color	Tab	Qty.	Unit	Price
16 SMD-64021	Letter	Blue	1/2-Cut	25	Box	40.90
17 SMD-64023	Letter	Purple	1/2-Cut	25	Box	40.90
18 SMD-64020	Letter	Assorted	1/2-Cut	25	Box	44.95

★ Paper contains 10% post-consumer recycled content, 10% total recycled content.  
SMD-64020—Blue; Green; Purple; Red; Yellow.



## C FASTAB® HANGING FOLDERS

Built-in heavy-duty tabs for quick and easy labeling—no plastic tabs required. Reinforced construction for extra durability and longer life. Easy to label by either handwriting directly on the tab or applying self-adhesive labels. This product was made using wood sourced from a certified managed forest. ♻️

ID No.	Size	Color	Tab	Qty.	Unit	Price
19 SMD-64099	Letter	Blue	1/2-Cut	20	Box	37.44
20 SMD-64098	Letter	Green	1/2-Cut	20	Box	37.44
21 SMD-64082	Letter	Moss	1/2-Cut	20	Box	37.44
22 SMD-64096	Letter	Red	1/2-Cut	20	Box	37.44
23 SMD-64037	Letter	Standard Green	1/2-Cut	20	Box	37.12
24 SMD-64097	Letter	Yellow	1/2-Cut	20	Box	37.44
25 SMD-64054	Letter	Assorted	1/2-Cut	18	Box	37.71
26 SMD-64053	Letter	Assorted	1/2-Cut	18	Box	37.71
27 SMD-64028	Letter	Assorted	1/2-Cut	18	Box	47.25
28 SMD-64083	Legal	Moss	1/2-Cut	20	Box	44.44
29 SMD-64137	Legal	Standard Green	1/2-Cut	20	Box	44.02

★ SMD-64099, SMD-64098, SMD-64082, SMD-64096, SMD-64097, SMD-64083—Paper contains 10% post-consumer recycled content, 10% total recycled content. SMD-64037, SMD-64137—Paper contains 100% post-consumer recycled content, 100% total recycled content.  
SMD-64054—Paper contains 10% post-consumer recycled content, 10% total recycled content. Camel; Lake Blue; Moss. SMD-64053—Paper contains 10% post-consumer recycled content, 10% total recycled content. Blue; Green; Red. SMD-64028—Blue; Green; Red. Poly material.



## D HANGING FOLDERS

Hanging folders keep papers neatly vertical in the file. No more slumping folders or folders that slip under one another. Includes tabs and inserts (unless otherwise noted). This product was made using wood sourced from a certified managed forest. ♻️

ID No.	Size	Color	Tab	Qty.	Unit	Price
30 SMD-64055	Letter	Standard Green	1/2-Cut	25	Box	39.55
31 SMD-64035	Letter	Standard Green	1/2-Cut	25	Box	40.40
32 SMD-64010	Letter	Standard Green	...	25	Box	29.25
33 SMD-64155	Legal	Standard Green	1/2-Cut	25	Box	46.95
34 SMD-64135	Legal	Standard Green	1/2-Cut	25	Box	48.35
35 SMD-64110	Legal	Standard Green	...	25	Box	37.40

★ Paper contains 10% post-consumer recycled content, 10% total recycled content.  
SMD-64010, SMD-64110—Does not include tabs and inserts.



## E BOX BOTTOM HANGING FILE FOLDERS

Ideal for bulky records, manuals, and catalogs. Reinforcement strip prevents bulging. Tabs and inserts not included in standard green items. Assorted expansions. This product was made using wood sourced from a certified managed forest. ♻️

ID No.	Size	Color	Expansion	Qty.	Unit	Price
36 SMD-64239	Letter	Standard Green	1"	25	Box	45.35
37 SMD-64259	Letter	Standard Green	2"	25	Box	49.55
38 SMD-64264	Letter	Assorted	2"	25	Box	61.65
39 SMD-64279	Letter	Standard Green	3"	25	Box	54.65
40 SMD-64339	Legal	Standard Green	1"	25	Box	53.15
41 SMD-64359	Legal	Standard Green	2"	25	Box	57.25
42 SMD-65095	Legal	Standard Green	2"	25	Box	64.75
43 SMD-64379	Legal	Standard Green	3"	25	Box	69.35

★ SMD-64239, SMD-64259, SMD-64279, SMD-64339, SMD-64359, SMD-64379—Paper contains 10% post-consumer recycled content, 10% total recycled content.  
SMD-64264—Paper contains 10% post-consumer recycled content, 10% total recycled content. Blue; Red; Yellow. Includes 1/2 cut poly tabs and inserts.  
SMD-65095—Paper contains 30% post-consumer recycled content, 100% total recycled content.



## F HANGING POCKETS WITH FULL-HEIGHT GUSSET

Hanging pockets are ideal for storing large amounts of paperwork. Full-height sides keep the pocket from getting caught when trying to take them out of a drawer or box. Documents are also better protected and secured in the pocket. Die cut handles allow for lifting and transporting. Great for files that need to be frequently removed from the file drawer. This product was made using wood sourced from a certified managed forest. ♻️

ID No.	Size	Color	Expansion	Qty.	Unit	Price
44 SMD-64218	Letter	Standard Green	1.75"	25	Box	151.50
45 SMD-64220	Letter	Standard Green	3.5"	10	Box	78.70
46 SMD-64290	Letter	Assorted	3.5"	4	PK	40.94
47 SMD-64318	Legal	Standard Green	1.75"	25	Box	175.25
48 SMD-64320	Legal	Standard Green	3.5"	10	Box	88.10
49 SMD-64250	Letter	Sky Blue	2"	25	Box	113.95
50 SMD-64270	Letter	Sky Blue	3"	25	Box	122.05
51 SMD-64370	Legal	Sky Blue	3"	25	Box	132.70

★ Paper contains 10% post-consumer recycled content, 10% total recycled content.  
SMD-64290—Blue; Red; Standard Green; Yellow.

**A**



**A Reinforced Top Tab Colored File Folders** Use a rainbow of colors to categorize different types of folders, which speeds filing and retrieval time, or to complement your company colors or décor. Multiple tab positions to fit any vertical or lateral filing system. Reinforced tab adds strength where you need it most. This product was made using wood sourced from a certified managed forest. ♻️ 🌱

ID No.	Size	Color	Tab	Qty.	Unit	Price
1 SMD-12034	Letter	Blue	½-Cut Assorted	100	Box	54.56
2 SMD-12234	Letter	Goldenrod	½-Cut Assorted	100	Box	54.56
3 SMD-12334	Letter	Gray	½-Cut Assorted	100	Box	54.56
4 SMD-12134	Letter	Green	½-Cut Assorted	100	Box	54.56
5 SMD-12434	Letter	Lavender	½-Cut Assorted	100	Box	54.56
6 SMD-13084	Letter	Maroon	½-Cut Assorted	100	Box	54.56
7 SMD-12534	Letter	Orange	½-Cut Assorted	100	Box	54.56
8 SMD-12634	Letter	Pink	½-Cut Assorted	100	Box	54.56
9 SMD-13034	Letter	Purple	½-Cut Assorted	100	Box	54.56
10 SMD-12734	Letter	Red	½-Cut Assorted	100	Box	54.56
11 SMD-13134	Letter	Teal	½-Cut Assorted	100	Box	54.56
12 SMD-12834	Letter	White	½-Cut Assorted	100	Box	54.56
13 SMD-12934	Letter	Yellow	½-Cut Assorted	100	Box	54.56
14 SMD-11641	Letter	Assorted	½-Cut Assorted	12	Pack	9.02
15 SMD-11993	Letter	Assorted	½-Cut Assorted	100	Box	58.00
16 SMD-12010	Letter	Blue	Straight	100	Box	62.00
17 SMD-12210	Letter	Goldenrod	Straight	100	Box	62.00
18 SMD-12310	Letter	Gray	Straight	100	Box	62.00
19 SMD-12110	Letter	Green	Straight	100	Box	62.00
20 SMD-12410	Letter	Lavender	Straight	100	Box	62.00
21 SMD-12510	Letter	Orange	Straight	100	Box	62.00
22 SMD-12610	Letter	Pink	Straight	100	Box	62.00
23 SMD-12710	Letter	Red	Straight	100	Box	62.00
24 SMD-12810	Letter	White	Straight	100	Box	62.00
25 SMD-12910	Letter	Yellow	Straight	100	Box	62.00
26 SMD-17034	Legal	Blue	½-Cut Assorted	100	Box	69.65
27 SMD-17234	Legal	Goldenrod	½-Cut Assorted	100	Box	69.65
28 SMD-17334	Legal	Gray	½-Cut Assorted	100	Box	69.65
29 SMD-17134	Legal	Green	½-Cut Assorted	100	Box	69.65
30 SMD-17434	Legal	Lavender	½-Cut Assorted	100	Box	69.65
31 SMD-17534	Legal	Orange	½-Cut Assorted	100	Box	69.65
32 SMD-17634	Legal	Pink	½-Cut Assorted	100	Box	69.65
33 SMD-17010	Legal	Blue	Straight	100	Box	79.68
34 SMD-17110	Legal	Green	Straight	100	Box	79.68
35 SMD-17410	Legal	Lavender	Straight	100	Box	79.68
36 SMD-17510	Legal	Orange	Straight	100	Box	79.68
37 SMD-17710	Legal	Red	Straight	100	Box	79.68

\* Paper contains 10% post-consumer recycled content, 10% total recycled content.  
 SMD-11641—Blue; Green; Red; Yellow.  
 SMD-11993—Blue; Green; Orange; Red; Yellow.

**B**



**B SuperTab® Colored File Folders** Designed with tabs that have more labeling area for improved labeling. Labels are easier to see using larger text or more lines of text can be visible. This product was made using wood sourced from a certified managed forest. ♻️ 🌱

ID No.	Size	Color	Tab	Qty.	Unit	Price
38 SMD-11956	Letter	Assorted	½-Cut Assorted	24	Pack	21.76
<b>Heavyweight 14 pt. stock</b>						
39 SMD-10410	Letter	Assorted	½-Cut Assorted	50	Box	41.44
40 SMD-15410	Legal	Assorted	½-Cut Assorted	50	Box	61.67
<b>11 pt. stock</b>						
41 SMD-11986	Letter	Blue	½-Cut Assorted	100	Box	55.55
42 SMD-11985	Letter	Green	½-Cut Assorted	100	Box	55.55
43 SMD-11983	Letter	Red	½-Cut Assorted	100	Box	55.55
44 SMD-11984	Letter	Yellow	½-Cut Assorted	100	Box	55.55
45 SMD-11987	Letter	Assorted	½-Cut Assorted	100	Box	66.59
46 SMD-11961	Letter	Assorted	½-Cut Assorted	100	Box	66.59

\* SMD-11956—Contains 10% post-consumer recycled content, 20% total recycled content. Blue; Green; Red; Yellow.  
 SMD-10410, SMD-15410, SMD-11987—Paper contains 10% post-consumer recycled content, 10% total recycled content. Blue; Green; Red; Yellow.  
 SMD-11986, SMD-11985, SMD-11983, SMD-11984—Paper contains 10% post-consumer recycled content, 10% total recycled content.  
 SMD-11961—Paper contains 10% post-consumer recycled content, 10% total recycled content. Camel; Lake Blue; Lavender; Moss; Pink.

**C**



**C Colored File Folders** Take advantage of one of the great organization tools—color! Various bright colors make color coding easy. This product was made using wood sourced from a certified managed forest. ♻️ 🌱

ID No.	Size	Color	Tab	Qty.	Unit	Price
47 SMD-12043	Letter	Blue	½-Cut Assorted	100	Box	42.33
48 SMD-12343	Letter	Gray	½-Cut Assorted	100	Box	42.33
49 SMD-12143	Letter	Green	½-Cut Assorted	100	Box	42.33
50 SMD-12443	Letter	Lavender	½-Cut Assorted	100	Box	42.33
51 SMD-13093	Letter	Maroon	½-Cut Assorted	100	Box	42.33
52 SMD-13193	Letter	Navy Blue	½-Cut Assorted	100	Box	42.33
53 SMD-12543	Letter	Orange	½-Cut Assorted	100	Box	42.33
54 SMD-12643	Letter	Pink	½-Cut Assorted	100	Box	42.33
55 SMD-13043	Letter	Purple	½-Cut Assorted	100	Box	42.33
56 SMD-12743	Letter	Red	½-Cut Assorted	100	Box	42.33
57 SMD-13143	Letter	Teal	½-Cut Assorted	100	Box	42.33
58 SMD-12843	Letter	White	½-Cut Assorted	100	Box	42.33
59 SMD-12943	Letter	Yellow	½-Cut Assorted	100	Box	42.33
60 SMD-11943	Letter	Assorted	½-Cut Assorted	100	Box	48.11
61 SMD-11948	Letter	Assorted	½-Cut Assorted	100	Box	48.11
62 SMD-11953	Letter	Assorted	½-Cut Assorted	100	Box	48.11
63 SMD-17043	Legal	Blue	½-Cut Assorted	100	Box	55.65
64 SMD-17143	Legal	Green	½-Cut Assorted	100	Box	55.65
65 SMD-17743	Legal	Red	½-Cut Assorted	100	Box	55.65
66 SMD-17943	Legal	Yellow	½-Cut Assorted	100	Box	55.65
67 SMD-16943	Legal	Assorted	½-Cut Assorted	100	Box	63.27

\* Paper contains 10% post-consumer recycled content, 10% total recycled content.  
 SMD-11943, SMD-16943—Blue; Green; Orange; Red; Yellow.  
 SMD-11948—Gray; Maroon; Navy; Purple; Teal.  
 SMD-11953—Camel; Lake Blue; Lavender; Moss; Pink.



# Office Furnishings Fire Protection & Security Mirrors

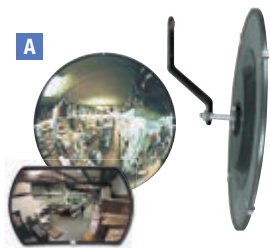

Adjustable arm permits wide range of viewing angles.



## SEE ALL®

### A - C SECURITY MIRROR

Scan unguarded aisles, eliminate blind intersections, monitor production areas and safeguard entrances and exits. Detection mirrors are curved to eliminate distortion.

### A 160° CONVEX SECURITY MIRROR

Double-strength glass. Adjusts for many viewing angles.

ID No.	Size	For Areas Up To	Unit	Price
<b>Circular</b>				
1 SEE-N12 ★	12"	10 sq ft	Each	46.00
2 SEE-N18 ★	18"	15 sq ft	Each	64.00
3 SEE-N26 ★	26"	20 sq ft	Each	95.00
<b>Round Rectangular Shape for Low Ceiling Areas</b>				
4 SEE-RR1218 ★	18" × 12"	15 sq ft	Each	80.00
5 SEE-RR1524 ★	24" × 15"	20 sq ft	Each	90.00

★ Meets OSHA Requirements.

### B HALF-DOME MIRROR

Panoramic® 180° viewing area for collision protection at intersections, as well as surveillance. Plexiglas® construction.

ID No.	Size	For Areas Up To	Unit	Price
6 SEE-PV18-180 ★	18"	150 sq ft	Each	70.00

★ Meets OSHA Requirements.

### C PORTABLE CONVEX MIRROR

OSHA-compliant, Plexiglas® convex clip-on security mirror with expanded view and articulating arm adapts to a variety of safety and security uses. 160° view angle. Manufacturer's one-year warranty against defects.

ID No.	Size	For Areas Up To	Unit	Price
7 SEE-ICU7 ★	7"	7 ft	Each	26.00
8 SEE-ICU10 ★	10"	10 ft	Each	37.00

★ Meets OSHA Requirements.

## UL FIRE CLASSIFICATIONS

**A Common Combustibles**—Wood, paper, cloth, rubber, trash and most plastics.

**B Flammable Liquids**—Gasoline, kerosene, oil, grease, solvents and paint.

**C Live Electrical Equipment**—Motors, computers, wiring and appliances. Requires a nonconductive extinguishing agent.



### D PRO 210 SERIES FIRE EXTINGUISHER

Multipurpose rechargeable fire extinguisher. Heavy duty chrome plated brass valve assembly. Pressure gauge allows for immediate pressure status check.

ID No.	CW/UW/UL	Material	Unit	Price
9 KID-21005779	4 lbs/7.5 lbs/2-A, 10-B:C	Aluminum; Monoammonium Phosphate	Each	76.99

### E PROLINE™ DRY-CHEMICAL COMMERCIAL FIRE EXTINGUISHER

Be prepared; choose ProLine™ dry-chemical extinguishers for your commercial fire-suppression needs. Crystal-clear, step-by-step instruction label helps ensure effective use in a crisis. Easy-to-read, reliable pressure gauge simplifies inspections. Manufacturer's limited six-year warranty.

ID No.	CW/UW/UL	Material	Unit	Price
10 KID-466227 ★	2.625 lbs/4½ lbs/1A-10B:C	Aluminum Cylinder; Monoammonium Phosphate	Each	60.37
11 KID-466112 ★	5 lbs/8½ lbs/3A-40B:C	Aluminum Cylinder; Monoammonium Phosphate	Each	56.28
12 KID-466204 ★	10 lbs/19 lbs/4A-60B:C	Steel Cylinder; Monoammonium Phosphate	Each	99.57

★ CW=Charge wt. lbs., UW=Unit wt. lbs., UL=UL rating.

### F AUTO FX511 DISPOSABLE AUTO FIRE EXTINGUISHER

Better safe than sorry: keep this ultra-reliable, easy-to-store extinguisher in your vehicle at all times. Sodium bicarbonate, dry-chemical system smothers flammable liquid and electronics fires. Pressure gauge enables at-a-glance charge-level checks. Manufacturer's limited six-year warranty.

ID No.	CW/UW/UL	Material	Unit	Price
13 KID-21006287MTL ★	2 lbs/2¾ lbs/5-B:C	Aluminum Cylinder; Sodium Bicarbonate	Each	21.84

★ CW=Charge wt. lbs., UW=Unit wt. lbs., UL=UL rating.

### G FULL HOME FIRE EXTINGUISHER 466142

Clear instruction label using graphics to show steps required to operate extinguisher. Easy-to-read gauge tells you fire extinguisher is charged and ready for use. Easy-to-pull safety pin.

ID No.	CW/UW/UL	Material	Unit	Price
14 KID-466142MTL	2.5 lbs/3.9 lbs/1-A, 10-B:C	Aluminum; Monoammonium Phosphate	Each	29.38

### H KITCHEN SMOKE AND CARBON MONOXIDE SEALED BATTERY ALARM

Make personal safety your priority with this combination smoke and carbon monoxide alarm. Unit comes equipped with a sealed-in lithium power supply that lasts the entire ten-year life of the alarm and eliminates concerns about battery removal and unauthorized alarm deactivation. It's quick and easy to install; alarm automatically activates when attached to the mounting bracket. Manufacturer's limited 10 year warranty.

ID No.	Qty.	Unit	Price
15 KID-21010071 ★	1	Each	79.99

★ UL Listed.





## A ANSI 2015 SMARTCOMPLIANCE GENERAL BUSINESS FIRST AID STATION

This general business kit is ideal for businesses, offices and worksites. The swing-out door and easy-to-carry handle add extra convenience. Clearly labeled compartments create a cabinet that is easy to use and restock. Expansion pocket allows you to customize your cabinet to meet your needs. This unique cabinet design eliminates disorganized and missing supplies.

ID No.	Size	Case Material	Unit	Price
--------	------	---------------	------	-------

### Medium 25 Person SmartCompliance First Aid Cabinet without Medications—94 pieces.

1	FAO-90578	3" × 9" × 11¼"	Metal	Kit	132.86
---	-----------	----------------	-------	-----	--------

### Large 50 Person SmartCompliance First Aid Cabinet with Medications—241 pieces.

2	FAO-90608	13" × 4½" × 14"	Plastic	Kit	199.36
---	-----------	-----------------	---------	-----	--------

### Large 50 Person SmartCompliance First Aid Cabinet without Medications—202 pieces.

3	FAO-90580	4¾" × 13¾" × 13¾"	Plastic	Kit	199.31
---	-----------	-------------------	---------	-----	--------

FAO-90578—ANSI/ISEA Z308.1-2015 Compliant; Class A.  
FAO-90608—ANSI/ISEA Z308.1-2015 Compliant; Class A+.  
FAO-90580—ANSI/ISEA Z308.1-2015.

## B ANSI 2015 COMPLIANT INDUSTRIAL FIRST AID KIT

This industrial first aid station is designed as an auxiliary kit for smaller businesses, offices and work sites. Contains a variety of products to take care of cuts and scrapes, eye irritations, CPR rescue, personal discomfort, minor burns, sprains, strains and bruises. The swing-down door and easy-to-carry handle make this first aid station extra convenient. Refills are color-coded for easy identification in an emergency.

ID No.	Size	Case Material	Unit	Price
--------	------	---------------	------	-------

### Three-Shelf Case with Medication, For Up to 100 People—676 pieces.

4	FAO-90575	5½" × 15" × 16"	Metal	Kit	221.46
---	-----------	-----------------	-------	-----	--------

### Two-Shelf Case with Medication, For Up To 75 People—446 pieces.

5	FAO-90573	4¾" × 10¾" × 15"	Metal	Kit	199.31
---	-----------	------------------	-------	-----	--------

FAO-90575—ANSI/ISEA Z308.1-2015 Compliant; Class A+ Type I & II; Meets or exceeds Federal OSHA Regulation 1910.151(b).  
FAO-90573—ANSI/ISEA Z308.1-2015 Compliant; Class B+ Type I & II; Meets or exceeds Federal OSHA Regulation 1910.151(b).

## C ANSI CLASS B+ 4 SHELF FIRST AID STATION WITH MEDICATIONS

Four shelf industrial first aid station is designed for businesses, offices and work sites. Sturdy solid steel case comes with a convenient carrying handle. Case is also wall mountable. Solid steel case comes with a carrying handle and is wall mountable. Sufficient to treat 150 to 200 people. 1461 pieces.

ID No.	Size	Case Material	Unit	Price
--------	------	---------------	------	-------

6	FAO-90576	17" × 6" × 22¼"	Metal	Kit	316.65
---	-----------	-----------------	-------	-----	--------

ANSI/ISEA Z308.1-2015 Compliant; Cabinet is ANSI Class B+ compliant; Contents exceed the 2015 ANSI Class B requirements.

## D BULK ANSI 2015 COMPLIANT FIRST AID KIT

Ensure employee safety with a convenient, handy plastic first aid kit, containing key items for office, vehicle and worksite kits. Supplies feature bilingual labels in English and Spanish for easy reading in an emergency.

ID No.	Size	Case Material	Unit	Price
--------	------	---------------	------	-------

### For Up to 25 People—89 pieces.

7	FAO-90588	8½" × 9½" × 2¾"	Plastic	Kit	39.71
---	-----------	-----------------	---------	-----	-------

### For Up to 25 People—141 pieces.

8	FAO-90589	10" × 2½" × 7"	Plastic	Kit	49.79
---	-----------	----------------	---------	-----	-------

FAO-90588—ANSI/ISEA Z308.1-2015 Compliant; Class A Type I & II.  
FAO-90589—ANSI/ISEA Z308.1-2015 Compliant; Class A+ Type I & II.

### Also Consider:

ID No.	Description	Qty.	Unit	Price
--------	-------------	------	------	-------

9	FAO-90583	25 Person, 89 Piece First Aid Kit Refill	1	Kit	33.18
---	-----------	--	---	-----	-------

## E FIRST AID STATION FOR UP TO 50 PEOPLE

Designed for contractors and vehicles. 20 first aid products, 196 pieces including bandages, compresses, eye care products, ointment, wipes, plus six-piece CPR pack. Metal case with handle. Wall mountable (hardware not incl.).

ID No.	Size	Case Material	Unit	Price
--------	------	---------------	------	-------

10	FAO-226-U	10½" × 2½" × 10½"	Metal	Kit	118.09
----	-----------	-------------------	-------	-----	--------

Meets or exceeds OSHA Requirements.

Prices subject to change without notice.

Visit our website for the latest pricing and product information.

# Office Furnishings First Aid



## A ANSI 2015 READCARE FIRST AID KIT

Convenient kit comes in an innovative plastic case with a carrying handle. Comes complete with all of the items needed to clean, treat and protect against a variety of everyday occurrences. Transparent door allows you to find items quickly in an emergency. Kit is conveniently wall mountable.

ID No.	Size	Case Material	Unit	Price
<b>For Up to 25 People</b> —139 pieces.				
1	FAO-90697 *	7" x 9" x 4"	Plastic	Kit 49.50
<b>For Up to 50 People</b> —238 pieces.				
2	FAO-90698 *	11" x 12" x 4"	Plastic	Kit 76.76
* ANSI/ISEA Z308.1-2015; Contents exceed the 2015 ANSI Class A+ requirement.				

## B ANSI CLASS A+ FIRST AID KIT

Plastic, organized case comes with a carrying handle. Conveniently wall mountable.

ID No.	Size	Case Material	Unit	Price
<b>For Up to 50 People</b> —183 pieces.				
3	FAO-90639 *	10" x 3" x 9"	Plastic	Kit 47.53
* ANSI/ISEA Z308.1-2015; Contents exceed the 2015 ANSI Class A+ requirement.				

### Also Consider:

ID No.	Description	Qty.	Unit	Price
4	FAO-90617	ANSI First Aid Kit Refill, 183 Piece	1	Kit 40.24

Physicians CARE By FIRST AID ONLY.

## C OFFICE FIRST AID KIT

You'll be prepared for emergencies indoors or outdoors with this reliable kit that features first aid products to care for cuts, scrapes and bruises, minor eye irritations, personal discomfort and minor burns. Dust- and moisture-resistant with long-lasting hinges and two latches.

ID No.	Size	Case Material	Unit	Price
<b>For Up to 25 People</b> —131 pieces.				
5	FAO-60002 *	7" x 3" x 10"	Plastic	Kit 52.50
* Meets or exceeds OSHA Requirements.				

## D FIRST AID KIT FOR USE BY UP TO 25 PEOPLE

113-piece kit that includes alcohol pads, antibiotic ointment, bandages, first aid cream, instant cold pack, scissors, tape, tweezers, gloves and a first aid guide.

ID No.	Size	Case Material	Unit	Price
6	FAO-25001 *	8" x 5½" x 29½"	Plastic	Kit 49.95
* Meets or exceeds OSHA Requirements.				



## E SAFE TRAVELS™ FIRST AID KIT

Don't let minor mishaps ruin your trip. The 70 essential first aid items in this kit will help you handle a variety of medical problems that might arise when you're on the road. Products will help you treat cuts and scrapes and relieve pain and itching. Includes an assortment of BAND-AID® adhesive bandages, cleansing wipes and antibiotic ointment. Comes in a compact, hard-shell case.

ID No.	Size	Case Material	Unit	Price
7	JOJ-8274	6¼" x 1½" x 5½"	Plastic	Kit 8.39



## F FIRST AID KIT IN METAL CASE FOR UP TO 25 PEOPLE

18 first aid products, 106 pieces in a metal case with mountable hanger for convenient removal and transport. (Mounting hardware not included).

ID No.	Size	Case Material	Unit	Price
<b>For Up to 25 People</b> —107 pieces.				
8	FAO-224-U *	10½" x 2½" x 7½"	Metal	Kit 56.24
* Meets or exceeds OSHA Requirements.				

## G ANSI CLASS A 10 PERSON BULK FIRST AID KIT

Convenient weatherproof case comes with a carrying handle. Case is easily wall mountable. Contents exceed the 2015 ANSI Class A requirements and are sufficient to treat up to 10 people.

ID No.	Size	Case Material	Unit	Price
9	FAO-90754 *	8" x 5" x 3"	Plastic	Kit 27.64
* ANSI/ISEA Z308.1-2015.				



**boardwalk.**

**A BLOOD CLEAN-UP KIT**

Convenient blood clean-up kit comes in a heavy-duty plastic case with safety latch and handle. Case is wall-mountable for easy access. Complete kit comes with an assortment of tools and disposable personal protective equipment to safely clean up blood or other potentially infectious materials. Includes disposable gloves, shoe covers, an apron, protective eyewear, and an isolation mask to help protect cleaning personnel.

ID No.	W × D × H	Unit	Price
1 BWK-54865 *	3" × 8" × 5"	Kit	30-11

\* Meets OSHA requirements.

**ZOLL.**

**B AED PLUS AUTOMATED EXTERNAL DEFIBRILLATOR**

The AED Plus is the first and only automated external defibrillator (AED) that provides Real CPR Help® for depth and rate of chest compressions during CPR. The AED Plus guides rescuers through the complete Chain of Survival helping all sudden cardiac arrest victims, not just those who need a shock.

ID No.	Qty.	Unit	Price
2 ZOL-80000400701 *	1	Each	2,100-00

**Fully Automatic AED Plus**—Includes one set of CPR-D-Padz, set of batteries, carry case and medical prescription.  
\* FDA Compliant.

**BAND-AID®**  
BRAND ADHESIVE BANDAGES

**C TRU-STAY SHEER STRIPS ADHESIVE BANDAGES**

For wound protection of minor cuts and scrapes. These sterile bandages provide lightweight, breathable protection.

ID No.	Description	Material	Qty.	Unit	Price
3 JOJ-4669 *	Assorted Sizes	Flex-Fabric	1	Box	6-60

\* Not made with natural rubber latex.

**D - E ADHESIVE BANDAGES**

Packaged for individual use and to replenish first aid stations and kits.

**D SHEER/WET FLEX ADHESIVE BANDAGES**

Adhesive bandages provide breathable protection.

ID No.	Description	Material	Qty.	Unit	Price
4 JOJ-4711	Assorted Sizes		280	Box	16-32

**E FLEXIBLE FABRIC ADHESIVE BANDAGES**

Extra-tough, durable and flexible fabric. Attaches with adhesive.

ID No.	Description	Material	Qty.	Unit	Price
5 JOJ-4444	1" × 3"	Fabric	100	Box	8-99
6 JOJ-11507800	Assorted Sizes	Fabric	100	Box	7-00

**NEOSPORIN®**

**F ANTIBIOTIC OINTMENT**

Provides long-lasting protection against infection and may help minimize the appearance of scars.

ID No.	Description	Qty.	Unit	Price
7 JOJ-512376900	0.032 oz Packets	144	Box	48-50



**G ALCOHOL SWABS**

The easy and convenient way to cleanse the skin and help decrease bacteria at the site of application. Individually sealed, two-fold quilted swabs are ideal for pre-injection skin prepping. Contains 70% isopropyl alcohol.

ID No.	Description	Qty.	Unit	Price
8 MII-CUR45581RBI	1" × 1"	200	Box	4-85

Prices subject to change without notice.  
Visit our website for the latest pricing and product information.



**A**



**B**

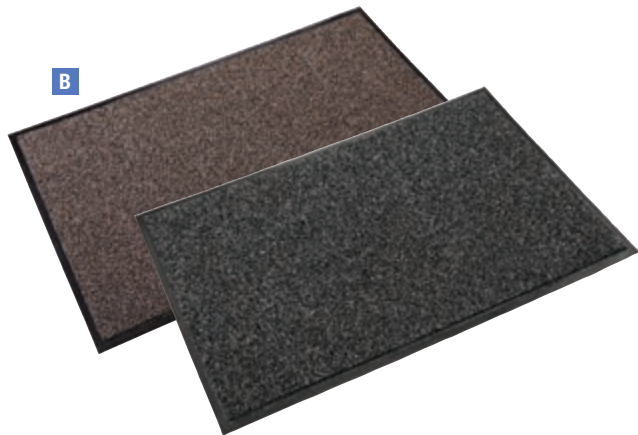

**C**

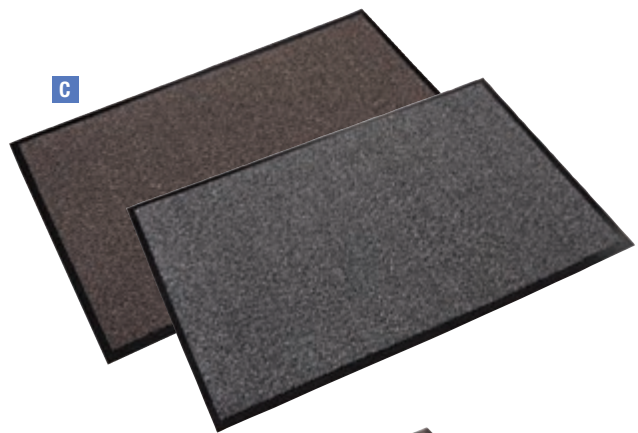

**D**



## A – C TOTAL CARE 3-MAT SYSTEM™

Keeping your building's indoor surfaces clean is as easy as 1-2-3. These mats are designed to work together at entryways with heavy foot-traffic, including those at office buildings, stores, schools, restaurants and hotels. Start outside with the Fore-Runner™ Scraper Mat. Then use the Cross-Over™ Wiper/Scraper Mat in the breezeway. The moisture-absorbent Walk-A-Way™ Wiper Mat completes the job in the foyer. Manufacturer's Total Confidence Warranty.

## A FORE-RUNNER™ INDOOR/OUTDOOR SCRAPER MAT

The tough, durable loop-twist construction of these outdoor floor mats scrapes off dirt and grit before it enters the building. Ideal for locations with a large number of daily visitors, including office buildings, universities, convention centers and resorts.

ID No.	Color	W × L	Qty.	Unit	Price	
1	CWN-FN-0035BR	Brown	36" × 60"	1	Each	<del>88.50</del>
2	CWN-FN-0035GY	Gray	36" × 60"	1	Each	<del>88.50</del>
3	CWN-FN-0046BR	Brown	48" × 72"	1	Each	<del>141.60</del>
4	CWN-FN-0046GY	Gray	48" × 72"	1	Each	<del>141.60</del>

## B CROSS-OVER™ INDOOR WIPER/SCRAPER MAT

Preventing dirt and moisture from entering your building doesn't always simply require laying a standard mat—sometimes you need something extra. These crossover mats solve this problem through a combination of tightly woven loops of Olefin and polypropylene ribbon.



ID No.	Color	W × L	Qty.	Unit	Price	
5	CWN-CS-0035BR	Brown	36" × 60"	1	Each	<del>103.50</del>
6	CWN-CS-0035GY	Gray	36" × 60"	1	Each	<del>103.50</del>
7	CWN-CS-0046BR	Brown	48" × 72"	1	Each	<del>165.60</del>
8	CWN-CS-0046GY	Gray	48" × 72"	1	Each	<del>165.60</del>

## C WALK-A-WAY™ INDOOR WIPER MAT

The superior wiping and absorbing power of these indoor floor mats make them an ideal companion to medium/heavy traffic areas. These plush, absorbent yarn mats give you the reassurance that all outdoor dirt and debris will stay off your floors. Features superior moisture absorbency and premium Olefin continuous filament that resists crushing.

ID No.	Color	W × L	Qty.	Unit	Price	
9	CWN-WA-0035BR	Brown	36" × 60"	1	Each	<del>88.50</del>
10	CWN-WA-0035GY	Gray	36" × 60"	1	Each	<del>88.50</del>
11	CWN-WA-0046BR	Brown	48" × 72"	1	Each	<del>141.60</del>
12	CWN-WA-0046GY	Gray	48" × 72"	1	Each	<del>141.60</del>

## D NEEDLE-RIB™ WIPER/SCRAPER MAT

Keep those unwanted guests—dirt and moisture—off the invite list by using Needle Rib™ wiper/scraper mats. Rugged grooves and ribbed polypropylene needle fibers trap and hide dirt before it enters your building or office. Vinyl edges reduce the risk of tripping, while a vinyl backing helps keep mat in place. Wear-resistant, color-fast design for light- to medium-traffic areas. For indoor use. Manufacturer's limited one-year warranty.  

ID No.	Color	W × L	Qty.	Unit	Price	
13	CWN-NR0023CH ★	Charcoal	24" × 36"	1	Each	<del>32.70</del>
14	CWN-NR0034BR ★	Brown	36" × 48"	1	Each	<del>65.40</del>
15	CWN-NR0034CH ★	Charcoal	36" × 48"	1	Each	<del>65.40</del>
16	CWN-NR0035BR ★	Brown	36" × 60"	1	Each	<del>81.75</del>
17	CWN-NR0035CH ★	Charcoal	36" × 60"	1	Each	<del>81.75</del>
18	CWN-NR0035GY ★	Gray	36" × 60"	1	Each	<del>81.75</del>
19	CWN-NR0046BR ★	Brown	48" × 72"	1	Each	<del>130.80</del>
20	CWN-NR0046CH ★	Charcoal	48" × 72"	1	Each	<del>130.80</del>
21	CWN-NR0046GY ★	Gray	48" × 72"	1	Each	<del>130.80</del>
22	CWN-NR0310BR ★	Brown	36" × 120"	1	Each	<del>163.50</del>
23	CWN-NR0310GY ★	Gray	36" × 120"	1	Each	<del>163.50</del>

★ Surface contains 50% total recycled content.





## A SUPER-SOAKER™ DIAMOND WIPER/SCRAPER MAT

You'll be fashionable and practical with this high-performance entryway mat. Combines multi-directional, ultra-dense polypropylene fibers with stylish design to create the ideal way to trap dirt and moisture in heavy-traffic areas. Crush-resistant, needle-punched top fibers maintain their color and dry quickly. SBR rubber reinforced face nubs prevent pile from crushing. Rubber border. Manufacturer's limited one-year warranty.

ID No.	Color	W × L	Qty.	Unit	Price
1 CWN-S1R035ST	Slate	36" × 60"	1	Each	<del>149.05</del>
2 CWN-S1R046ST	Slate	46" × 72"	1	Each	<del>238.35</del>
3 CWN-S1R310ST	Slate	36" × 120"	1	Each	<del>297.95</del>

## B MAT-A-DOR™ ENTRANCE SCRAPER MAT

Want some tips for keeping your building and office free from dirt and debris? Here are 2,700 of them. That's how many shoe-cleaning rubber fingertips there are per square foot on these mats. Beveled edges keep the mat flat and reduce tripping hazards. Easy-to-clean design saves you time and energy. Manufacturer's limited one-year warranty.

ID No.	Color	W × L	Qty.	Unit	Price
4 CWN-MASR42BK	Black	24" × 32"	1	Each	<del>89.25</del>
5 CWN-MAFG62BK	Black	36" × 72"	1	Each	<del>289.00</del>

## C SUPER-SOAKER™ WIPER/SCRAPER MAT WITH GRIPPER BOTTOM

Need help getting a grip on dirt and moisture? Loop pile polypropylene fibers remove dirt and moisture, keeping your building clean and safe. The no-slip bottom creates a secure grip to carpets and smooth floors. Equipped with rubber backing and edges. Vacuum or professionally clean. Manufacturer's limited one-year warranty.

ID No.	Color	W × L	Qty.	Unit	Price
6 CWN-SSR023CH	Charcoal	24" × 36"	1	Each	<del>53.19</del>
7 CWN-SSR035CH	Charcoal	36" × 60"	1	Each	<del>132.75</del>
8 CWN-SSR035DB	Dark Brown	36" × 60"	1	Each	<del>132.75</del>
9 CWN-SSR046CH	Charcoal	46" × 72"	1	Each	<del>212.40</del>
10 CWN-SSR046DB	Dark Brown	46" × 72"	1	Each	<del>212.40</del>
11 CWN-SSR310CH	Charcoal	36" × 120"	1	Each	<del>265.50</del>
12 CWN-SSR310DB	Dark Brown	36" × 120"	1	Each	<del>265.50</del>

## D OXFORD™ WIPER MAT

Beautifully designed—a combination of performance and appearance like no other wiper! An elegant solution for a good first impression. High performance mat retains water and minimizes the risk of slips and falls. Heavyweight loop pile mat that exceeds performance. Attractive pattern hides dirt and keeps your entrances clean. Manufacturer's limited one-year warranty.

ID No.	Color	W × L	Qty.	Unit	Price
13 CWN-OXH035BR	Black/Brown	36" × 60"	1	Each	<del>152.25</del>
14 CWN-OXH046BR	Black/Brown	48" × 72"	1	Each	<del>243.60</del>

## E MARATHON™ WIPER/SCRAPER MAT

High-performance design that will keep its appearance for many years and won't let you down. This mat is an intelligent solution to reduce maintenance costs and protect floors. As a wiper/scraper mat, the heavy-duty needle punch surface will trap dirt and retain moisture—leaving floors cleaner. UV-, stain-, and abrasion-resistant is perfect for interior areas where heavy foot traffic over 1,500 persons per day. Reinforced latex coated pattern provides increased durability. Thick premium Thermo-Grip™ vinyl backing offers superior protection. Manufacturer's limited one-year warranty.

ID No.	Color	W × L	Qty.	Unit	Price
15 CWN-MN0035DB	Dark Brown	36" × 60"	1	Each	<del>154.50</del>
16 CWN-MN0046DB	Dark Brown	48" × 72"	1	Each	<del>247.20</del>

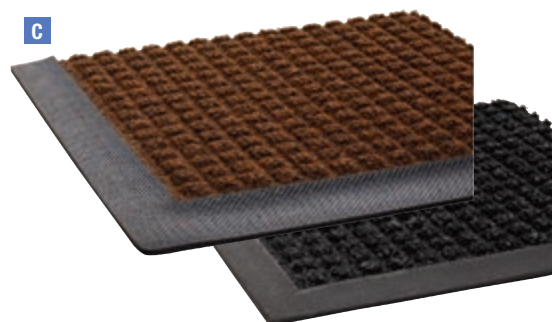
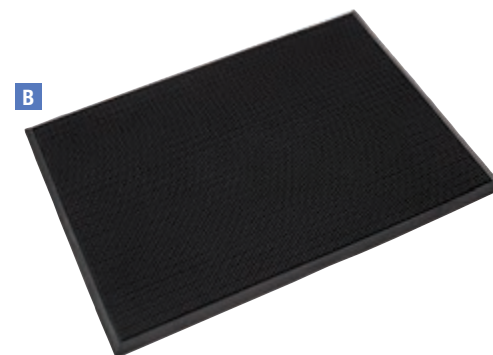

# Office Furnishings Floor Mats & Wipers

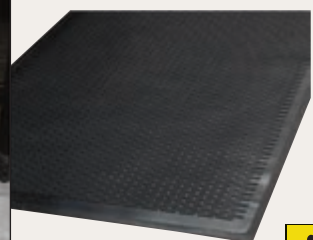
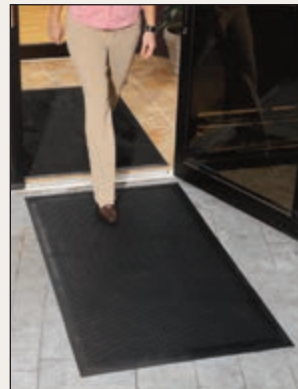
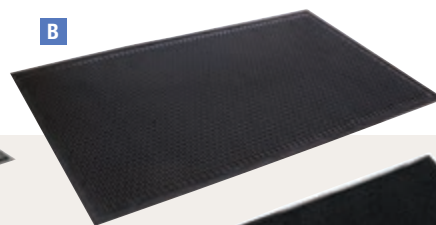

Use the outdoor scraper mat together with the indoor wiper mat (sold separately) for maximum floor protection.

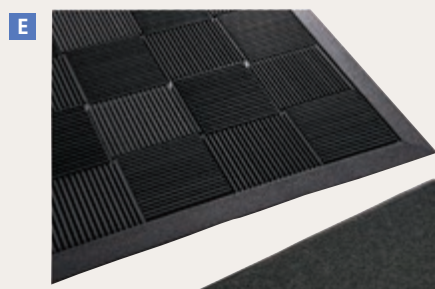

Chocolate

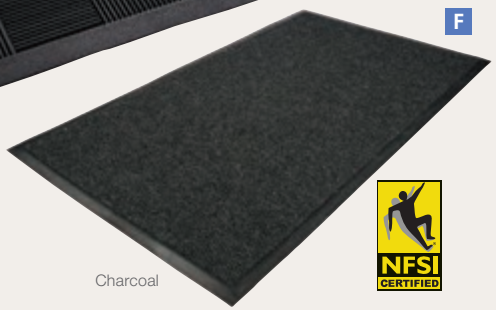

Charcoal



## A RELY-ON™ OLEFIN INDOOR WIPER MAT

Economical continuous filament olefin on standard vinyl is ideal for light to medium traffic. Plush surface dries moisture from shoes—holds up to ¾ gallon of water per square yard. Gentle, color-blend pattern complements any décor. Manufacturer's limited one-year warranty.

ID No.	Color	W × L	Qty.	Unit	Price	
1	CWN-GS0023CH	Charcoal	24" × 36"	1	Each	27.30
2	CWN-GS0034CH	Charcoal	36" × 48"	1	Each	54.60
3	CWN-GS0034WA	Walnut	36" × 48"	1	Each	54.60
4	CWN-GS0035CR	Castellan Red	36" × 60"	1	Each	68.25
5	CWN-GS0035CH	Charcoal	36" × 60"	1	Each	68.25
6	CWN-GS0035MB	Marlin Blue	36" × 60"	1	Each	68.25
7	CWN-GS0035WA	Walnut	36" × 60"	1	Each	68.25
8	CWN-GS0046CR	Castellan Red	48" × 72"	1	Each	109.20
9	CWN-GS0046CH	Charcoal	48" × 72"	1	Each	109.20
10	CWN-GS0046EG	Evergreen	48" × 72"	1	Each	109.20
11	CWN-GS0046MB	Marlin Blue	48" × 72"	1	Each	109.20
12	CWN-GS0046WA	Walnut	48" × 72"	1	Each	109.20
13	CWN-GS0310CH	Charcoal	36" × 120"	1	Each	136.50
14	CWN-GS0310WA	Walnut	36" × 120"	1	Each	136.50

## B CROWN-TRED™ INDOOR/OUTDOOR SCRAPER MAT

Excellent anti-skid surface. Ideal for heavy traffic areas. Gripper backing reduces mat movement. Manufacturer's limited one-year warranty.

ID No.	Color	W × L	Qty.	Unit	Price	
15	CWN-TD0035BK	Black	35½" × 59½"	1	Each	86.45
16	CWN-TD0046BK	Black	43¾" × 66¾"	1	Each	166.95

## C JASPER INDOOR/OUTDOOR SCRAPER MAT

This mat will keep its scraping capabilities in rough conditions for a long period of time. The slim profile allows for a low-door swing plus cleaning is simple, use a wet/dry vacuum or shake off. Outdoor/indoor entrance and lobby mat in medium traffic areas. Manufacturer's limited one-year warranty.

ID No.	Color	W × L	Qty.	Unit	Price	
17	CWN-JS0035BK	Black	36" × 60"	1	Each	82.50
18	CWN-JS0035GY	Gray	36" × 60"	1	Each	82.50
19	CWN-JS0046BK	Black	48" × 72"	1	Each	132.00
20	CWN-JS0046GY	Gray	48" × 72"	1	Each	132.00



## D CLEAN STEP OUTDOOR RUBBER SCRAPER MAT

This outdoor mat's molded tread aggressively removes dirt and grime from shoes, stopping dirt and grime from entering your business. Ideal for any outside entranceways. ♻️

ID No.	Color	W × L	Qty.	Unit	Price	
21	MLL-14030500 ★	Black	36" × 60"	1	Each	77.48
22	MLL-14040600 ★	Black	48" × 72"	1	Each	135.34

★ NFSI Certified. Contains 50% post-consumer recycled content, 50% total recycled content.

## E PARQUET WIPER SCRAPER MAT

Ideal for any outside entryway, the superior molded parquet pattern wipes shoes clean of dirt and grime, then traps it at the base of the mat. Made of 100% rubber, these strong scraper mats are a perfect first step for any floor protection system. Manufacturer's limited two-year warranty.

ID No.	Color	W × L	Qty.	Unit	Price	
23	MLL-PARQUET2X3	Black	24" × 36"	1	Each	42.92
24	MLL-PARQUET3X5	Black	36" × 60"	1	Each	105.87

## F ELITEGUARD INDOOR/OUTDOOR FLOOR MAT

These indoor mats are manufactured using high quality, durable, stain-resistant polypropylene fiber. This fiber allows us to craft unique mats that offer outstanding walk-off performance for heavy, multi-directional traffic applications. These mats may be custom cut, seamed and tailored to most any specific dimensions both large and small. Ideal for use in entranceways, indoor and outdoor, high traffic areas, vestibules and revolving doors. Manufacturer's limited three-year warranty. ♻️

ID No.	Color	W × L	Qty.	Unit	Price	
25	MLL-UGMM030504 ★	Charcoal	36" × 60"	1	Each	250.14
26	MLL-UGMM030514 ★	Chocolate	36" × 60"	1	Each	250.14

★ NFSI Certified. Contains 15% post-consumer recycled content, 15% total recycled content.



## A PLATINUM SERIES WALK-OFF INDOOR WIPER MAT

These indoor mats feature plush, solution-dyed nylon carpet for better absorption and colorfastness. The all-rubber backing means long lasting performance and maximum durability. These mats are simple to clean—just vacuum, use a carpet cleaner or commercially wash. Mats are certified "High Traction" by the National Floor Safety Institute (NFSI).

ID No.	Color	W × L	Qty.	Unit	Price	
1	MLL-94030535	Black	36" × 60"	1	Each	96.43
2	MLL-94030550	Brown	36" × 60"	1	Each	84.74
3	MLL-94040635	Black	48" × 72"	1	Each	128.18
4	MLL-94040650	Brown	48" × 72"	1	Each	144.42
5	MLL-94031035	Black	36" × 120"	1	Each	169.48
6	MLL-94031050	Brown	36" × 120"	1	Each	169.48

★ NFSI Certified.

## B GOLDEN SERIES DUAL RIB INDOOR WIPER MATS

These indoor mats feature ribbed polypropylene carpeting which captures dirt and moisture on contact and then keeps them in the mat and off of other areas in your building. Features chemical-resistant vinyl backing. Ideal for use on hard surface floors and low-pile carpet, and in entrance ways, hallways, lobbies, and low traffic walkways. Manufacturer's limited one-year warranty.

ID No.	Color	W × L	Qty.	Unit	Price	
7	MLL-64030520	Brown	36" × 60"	1	Each	84.12
8	MLL-64030530	Charcoal	36" × 60"	1	Each	72.26
9	MLL-64040620	Brown	48" × 72"	1	Each	119.04
10	MLL-64040630	Charcoal	48" × 72"	1	Each	97.21
11	MLL-64031020	Brown	36" × 120"	1	Each	127.06
12	MLL-64031030	Charcoal	36" × 120"	1	Each	127.06



## C CUSHION-STEP™ SURFACE MAT

When the job calls for spending a lot of time on your feet, it helps if you're on a comfortable surface. This mat's top is fused to thick sponge foam to help relieve some of the stress and discomfort that comes from standing for several minutes or hours. Features beveled edges and rounded corners to keep mat flat and help prevent falls. Manufacturer's limited one-year warranty.

ID No.	Color	W × L	Qty.	Unit	Price	
<b>Marbleized Rubber Surface</b>						
13	CWN-CU2436BK	Black	24" × 36"	1	Each	103.19
14	CWN-CU3660BK	Black	36" × 60"	1	Each	257.99
15	CWN-CU3660GY	Gray	36" × 60"	1	Each	257.99
16	CWN-CU3672BK	Black	36" × 72"	1	Each	315.54
17	CWN-CU3672GY	Gray	36" × 72"	1	Each	315.54
<b>Vinyl Surface</b>						
18	CWN-CU3660SB	Black	36" × 60"	1	Each	235.66
19	CWN-CU3660SF	French Gray	36" × 60"	1	Each	235.66

## D INDUSTRIAL DECK PLATE ANTI-FATIGUE MAT

Make safety and comfort the standard practice at your workplace. These mats feature a durable, slip-resistant surface with a diamond pattern texture to help reduce the risk of falling. Industrial-grade PVC foam backing fused to the top surface provides the comfort. Resistant to most common fluids and chemicals. Beveled edges help increase safety by reducing the risk of tripping. Manufacturer's limited one-year warranty.

ID No.	Color	W × L	Qty.	Unit	Price	
20	CWN-CD0023DB	Black	24" × 36"	1	Each	83.10
21	CWN-CD0023YB	Black/ Yellow Border	24" × 36"	1	Each	90.00
22	CWN-CD0035DB	Black	36" × 60"	1	Each	207.75
23	CWN-CD0035YB	Black/ Yellow Border	36" × 60"	1	Each	225.00
24	CWN-CD0312DB	Black	36" × 144"	1	Each	490.60

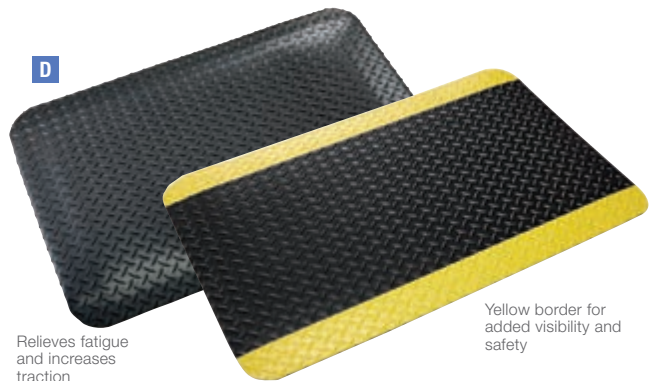
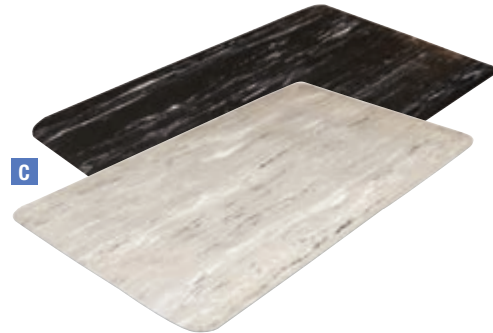

Prices subject to change without notice.  
Visit our website for the latest pricing and product information.



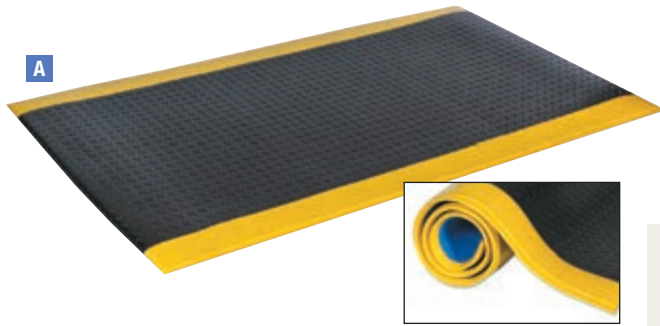

**A**



**B**

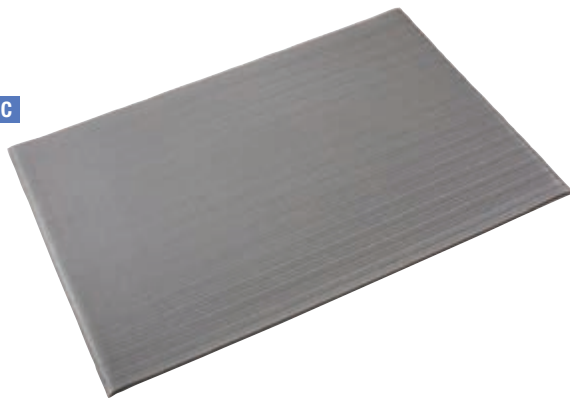

**C**



**D**



### A WEAR-BOND™ COMFORT-KING™ ANTI-FATIGUE MAT

Ideal ergonomic solution for people seeking comfort and long-term durability! Highly energized Zedlan™ sponge combines softness, resilience, and durability for exceptional relief. Features puncture resistance and five times the abrasion resistance of traditional sponge products. Wear-Bond™ process molecularly bonds layers together without the use of adhesives. Greater overall comfort than hard deck plate type surface. Medium duty applications for dry areas such as work stations, pick modules, pharmacies, packaging areas, cashier stations, etc. Manufacturer's limited one-year warranty.

ID No.	Color	W × L	Qty.	Unit	Price
1 CWN-WBZ023KD	Black	24" × 36"	1	Each	51.90
2 CWN-WBZ023YD	Black/Yellow	24" × 36"	1	Each	55.50
3 CWN-WBZ035KD	Black	36" × 60"	1	Each	129.75
4 CWN-WBZ035YD	Black/Yellow	36" × 60"	1	Each	138.75
5 CWN-WBZ312KD	Black	36" × 144"	1	Each	311.40
6 CWN-WBZ312YD	Black/Yellow	36" × 144"	1	Each	333.00

### B COMFORT-KING™ WITH ZEDLAN™ FOAM ANTI-FATIGUE MAT

A long day of standing on the job can take its toll on feet, ankles, legs and back, so take the necessary precautions to reduce the stress. These anti-fatigue mats are made of Zedlan™ foam, a highly elastic compound that is three times more resilient than vinyl foam. It's just the thing to help keep workers comfortable and healthy. Manufacturer's limited one-year warranty.

ID No.	Color	W × L	Qty.	Unit	Price
7 CWN-CK0023BL	Royal Blue	24" × 36"	1	Each	48.60
8 CWN-CK0035BL	Royal Blue	36" × 60"	1	Each	121.50

### C RIBBED VINYL ANTI-FATIGUE MAT

Are you and your workers on your feet for extended periods? The cushiony surface on these mats offers the comfort you need. Heavy-duty design is able to withstand an industrial working environment. Manufacturer's limited one-year warranty.

ID No.	Color	W × L	Qty.	Unit	Price
9 CWN-FL2436BK	Black	24" × 36"	1	Each	30.00
10 CWN-FL2436GY	Gray	24" × 36"	1	Each	30.00
11 CWN-FJS736GY	Gray	27" × 36"	1	Each	33.75
12 CWN-FL3660BK	Black	36" × 60"	1	Each	75.00
13 CWN-FL3660GY	Gray	36" × 60"	1	Each	75.00
14 CWN-FL3610GY	Gray	36" × 120"	1	Each	154.50



### D ADAPTIVERGO® ANTI-FATIGUE MAT

Encourage proper ergonomics and reduce fatigue with this cushioned standing mat. Beveled edge lays flat on the floor to reduce trip hazards. Rubber and vinyl construction ensures long lasting resiliency and cushioning. Ideal for use at sit-to-stand workstations, service counters, breakrooms, or wherever standing is required. Easy to clean surface with molded grid pattern to catch dirt and spills. Combine with Alera® AdaptivErgo™ Height Adjustable Tables or Alera® AdaptivErgo™ Lifting desks for even more ergonomic benefits with your sit-to-stand workstations. Manufacturer's limited five-year warranty.

ID No.	Color	W × L	Qty.	Unit	Price
15 ALE-AE23AFM	Black	24" × 36"	1	Each	99.00





## A PRO TOP ANTI-FATIGUE MAT

Features vinyl over foam construction that ensures higher durability and better resilience. These mats are both durable and economical and provide support for the back, legs and feet. They also feature a puncture-resistant surface for maximum durability and beveled edges that help reduce the risk of slips, trips and falls. Easy to clean—just wipe it off. Manufacturer's limited one-year warranty.

ID No.	Color	W × L	Qty.	Unit	Price
1 MLL-44020335	Black	24" × 36"	1	Each	74.55
2 MLL-44020350	Gray	24" × 36"	1	Each	74.55
3 MLL-44030535	Black	36" × 60"	1	Each	158.02
4 MLL-44030550	Gray	36" × 60"	1	Each	158.02

## B SOFT STEP SUPREME ANTI-FATIGUE FLOOR MAT

These commercial grade anti-fatigue mats feature a vinyl foam construction to ensure higher durability and better resilience. The pebble surface is pleasing to stand on and reduces fatigue and discomfort. Constructed from a vinyl/nitrile blend for maximum comfort and resilience. The beveled edges allow for a smooth transition from floor to mat. Manufacturer's limited one-year warranty.

ID No.	Color	W × L	Qty.	Unit	Price
5 MLL-24020301DIAM	Black	24" × 36"	1	Each	56.71
6 MLL-24030501DIAM	Black	36" × 60"	1	Each	141.77

## C FLEX STEP RUBBER ANTI-FATIGUE MAT

These anti-fatigue mats are commercial grade with a ¾" thickness and air domes that provide comfort for your legs, feet and back. Beveled edges increase safety by helping prevent trips and falls. Made with recycled rubber for maximum durability and are fully recyclable. The Flex Step Series of mats received the APMA (American Podiatric Medical Association) Seal of Acceptance for promoting foot health. Certified 'High Traction' by the National Floor Safety Institute (NFSI).

ID No.	Color	W × L	Qty.	Unit	Price
7 MLL-24020300 *	Black	24" × 36"	1	Each	50.07
8 MLL-24030500 *	Black	36" × 60"	1	Each	124.35

\* APMA Seal of Acceptance; NFSI Certified. Contains 50% post-consumer recycled content, 50% total recycled content.

## D AIR STEP ANTI-FATIGUE MAT

Provide your workers with comfort and safety with an Anti Fatigue Mat. Vinyl foam structure makes standing for a long time more comfortable and reduces stress, while the ribbed surface increases safety by helping to reduce dangerous slips and falls.

ID No.	Color	W × L	Qty.	Unit	Price
9 MLL-24020302	Black	24" × 36"	1	Each	28.57
10 MLL-24030502	Black	36" × 60"	1	Each	80.89
11 MLL-24031202	Black	36" × 144"	1	Each	205.81

## E FEEL GOOD® ANTI-FATIGUE FLOOR MAT

Choose to feel good with sturdy, ergonomically-designed mats featuring a domed surface that provides outstanding fatigue relief. Excellent for use in a variety of continuous standing applications to eliminate discomfort. Tapered edges and rounded corners eliminate trip hazard. Waffle base grips floor. Manufacturer's limited two-year warranty.

ID No.	Surface	Overall (W × L)	Lip (W × L)	Unit	Price
12 ESR-184552	Raised Dome	24" × 36"	No Lip	Each	99.99
13 ESR-184543	Raised Dome	35" × 60"	No Lip	Each	160.00
14 ESR-184545	Raised Dome	35" × 120"	No Lip	Each	260.00

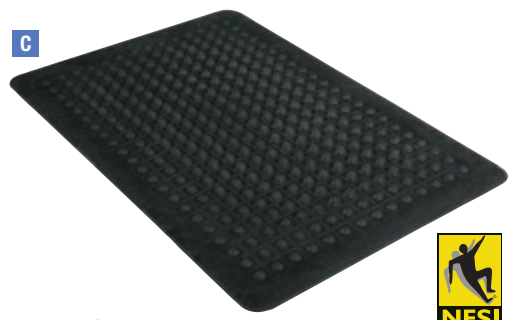
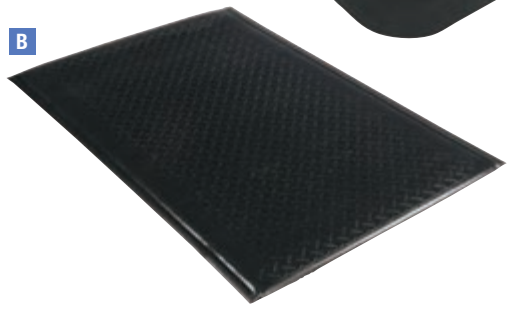
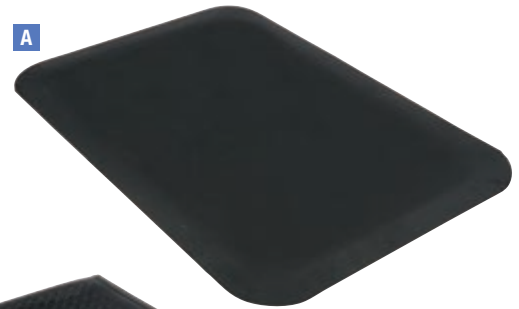

# Office Furnishings Frames



## DAX®

### A 2-TONE DOCUMENT FRAME

Showcase your memorable achievements with these trend-right document frames accented with contrasting inner lips. Includes a stylish double beveled mat that accommodates a smaller photo or certificate. The mat can be removed for a full size print or certificate if needed.

ID No.	Insert Size	Frame Color	Qty.	Unit	Price
1 DAX-N16984NT	8½" × 11"	Black/Silver	1	Each	17.99
2 DAX-N16982NT	8½" × 11"	Gray/Bronze	1	Each	17.99
<b>11 × 14</b> —Features black matting.					
3 DAX-N16982ST	8½" × 11"	Gray/Bronze	1	Each	26.29
<b>11 × 14</b> —Features white matting with a black outline.					
4 DAX-N16984ST	8½" × 11"	Black/Silver	1	Each	26.29

### B BASICS TEXTURE FRAME

Document frame with wood grain texture finish is ideal for your office, home or studio. Includes usable certificate. Can be displayed vertically or horizontally. All sizes can be displayed on the wall.

ID No.	Insert Size	Frame Color	Qty.	Unit	Price
5 DAX-NDWT8511BT *	8.5 × 11	Black	1	Each	17.99
6 DAX-NDWT1114BT *	11 × 14 matted to 8½ × 11	Black	1	Each	24.99

\* DAX-NDWT8511BT—Contains 60% total recycled content. Includes two-way easel.  
DAX-NDWT1114BT—Contains 98% total recycled content.

### C CONTEMPORARY WOOD DOCUMENT FRAME

Visitors to your home or office will take a second look at whatever you put in this contemporary black wood frame with a silver metal mat. Your certificate, award or diploma will appear to "float". Your important document deserves those second looks and this unusual, attractive frame will be the way to do it. Easel back for desktop; also hangs vertically or horizontally. 11 × 14 size is matted to 8½ × 11. Includes a usable certificate.

ID No.	Insert Size	Frame Color	Qty.	Unit	Price
7 DAX-N15788ST *	11 × 14 matted to 8½ × 11	Black	1	Each	26.29

\* California Air Resources Board (CARB) Compliant.

### D SOLID WOOD DOCUMENT FRAME SET

Matched pair of frames professionally displays achievement certificates, documents or photos. Easel back for desktop. Hangs vertically or horizontally. Usable certificates included.

ID No.	Insert Size	Frame Color	Qty.	Unit	Price
<b>Value Pack</b> —Stock up and save!					
8 DAX-N15832	8½ × 11	Black	2	Set	27.29

### E SOLID WOOD FRAME

Proudly display your photographs and pictures in this sleek frame with a flat, contemporary profile. Made of quality black solid wood that comes from well-managed forests. Frame has easel back for desktop display.

ID No.	Insert Size	Frame Color	Qty.	Unit	Price
9 DAX-1826H3T *	5 × 7	Black	1	Each	10.49
<b>Includes Hangers for Wall Display</b>					
10 DAX-1826L3T *	8 × 10	Black	1	Each	13.49
<b>Includes Hangers for Wall Display and Usable Certificate</b>					
11 DAX-1826N3T *	8½ × 11	Black	1	Each	15.79

\* California Air Resources Board (CARB) Compliant.

### F VALUE U-CHANNEL DOCUMENT FRAME

Sleek, contemporary styling gives employee awards an upscale look. Includes one blank certificate. Die-cut easel back for desktop use; hangs vertically or horizontally. Protective plastic face.

ID No.	Insert Size	Frame Color	Qty.	Unit	Price
12 DAX-N17000N	8½ × 11	Black	1	Each	5.99
<b>Value Pack</b> —Stock up and save!					
13 DAX-N17000NTP	8½ × 11	Black	2	Set	10.49



**A – C POSTER FRAMES**

Clear unbreakable plastic window provides protection for your favorite print. Lightweight construction. Hangs vertically or horizontally.

**A FLAT FACE POSTER FRAME**

3/4" flat face profile frame.

ID No.	Insert Size	Frame Color	Qty.	Unit	Price
1 DAX-2860V2X *	16 × 20	Black	1	Each	22-99
2 DAX-2860W2X *	18 × 24	Black	1	Each	28-49
3 DAX-286036X *	24 × 36	Black	1	Each	39-99

\* California Air Resources Board (CARB) Compliant.

**B BLACK SOLID WOOD POSTER FRAMES**

Handsome, wide-profile frame design. Lightweight construction. Hangs vertically or horizontally.

ID No.	Insert Size	Frame Color	Qty.	Unit	Price
4 DAX-2863V2X	16 × 20	Black	1	Each	24-49
5 DAX-2863W2X	18 × 24	Black	1	Each	30-99
6 DAX-2863U2X	24 × 36	Black	1	Each	47-29

**C COLOREGE POSTER FRAME**

Black plastic U-channel border for ultra-contemporary look.

ID No.	Insert Size	Frame Color	Qty.	Unit	Price
7 DAX-N16016BT *	16 × 20	Black	1	Each	18-79
8 DAX-N16018BT *	18 × 24	Black	1	Each	24-49
9 DAX-N16024BT *	24 × 36	Black	1	Each	39-29

\* California Air Resources Board (CARB) Compliant.

20-MF-L-FCL

# Office Furnishings Hand Carts & Trucks



## A 3-IN-1 CONVERTIBLE HAND TRUCK

This hand truck has an easy one-hand conversion for 3 different uses tool free in just seconds. Use as two wheel hand truck or convert to assisted hand truck or four wheel hand cart for heavy-duty loads. Perfect for transporting supplies or equipment in any commercial environment. Features include lightweight commercial-grade aluminum frame, wheel guards that protect cargo from contacting the wheels and a center cross bar which keeps load from falling during transport. Also features flat free foam tires. Manufacturer's limited five-year warranty.

ID No.	Capacity	Folded Size	Toe Plate Size	Shpg. Wt.	Unit	Price
1 CSC-12312ABL1E *	2-Wheel Capacity: 800 lbs; 4-Wheel Capacity: 1000 lbs	21.06w" x 45.08d" x 36.81h"	19 x 10.5	36 lbs.	Each	611.55

\* Overall Dimensions: 21.06"w x 21.85"d x 48.03"h.



## B UTILITY DUTY HOME AND OFFICE CART

Trolley efficiently transports large bulky loads and then folds flat for easy storage. Sturdy structural foam deck won't rust, dent, chip, or peel. 3-position handle allows the user to push, pull, or fold flat for use as a dolly. Tough plastic construction is easy on walls and doors. 3-inch casters are non-marking. Manufacturer's limited one-year warranty.

ID No.	Platform Size	Capacity	Caster/ Wheel Type	Shpg. Wt.	Unit	Price
2 RCP-440000	20.5 x 32.5	250 lbs	(4) 3" Non-Marking Casters; (2) Swivel	21 lbs.	Each	237.08

## C HEAVY-DUTY PLATFORM TRUCK

Constructed from Duramold resin and metal composite for durability and strength. Features molded-in tie-down slots and a textured surface to keep loads secure during transport. Has 2 fixed casters and 2 swivel casters to improve maneuverability. Manufacturer's limited one-year warranty.

ID No.	Platform Size	Capacity	Caster/ Wheel Type	Shpg. Wt.	Unit	Price
3 RCP-443600BK	24 x 48	2,000 lbs	(4) 8" Casters (2 Swivel)	73 lbs.	Each	919.92



## D STOW-AWAY® COLLAPSIBLE HAND TRUCK

Lightweight aluminum frame. Folds flat for compact storage. Features telescoping handle, retractable wheels and fold-up toeplate. Solid rubber tires.

ID No.	Capacity	Folded Size	Toe Plate Size	Shpg. Wt.	Unit	Price
4 SAF-4062 *	275 lbs	19 x 2.75 x 28.75	11 x 19	17 lbs.	Each	223.00

\* GREENGUARD Certified. Overall Dimensions: 19 x 17.75 x 38.75.

## E STOW & GO™ CART

Lightweight aluminum frame folds down to the size of a briefcase, fitting under car seats and airplane overhead compartments. Features telescoping handle, retractable wheels and fold-up toeplate. Ships fully assembled.

ID No.	Capacity	Folded Size	Toe Plate Size	Shpg. Wt.	Unit	Price
5 SAF-4049 *	110 lbs	15.25 x 2.5 x 25	15.25 x 11	8 lbs.	Each	141.00

\* GREENGUARD Certified. Overall Dimensions: 15.75 x 16.25 x 39.5.

## F TWO-WAY CONVERTIBLE HAND TRUCK

Converts from two-wheel hand truck to four-wheel platform truck (two swivel casters). Power Grasp Handle™ grip with Therasoft Comfort treads. Welded steel construction designed for the toughest industrial environments.

ID No.	Capacity	Toe Plate	Caster/ Wheel Type	Shpg. Wt.	Unit	Price
6 SAF-4086R *	2-Wheel Capacity: 500 lbs; 4-Wheel Capacity: 600 lbs	8 x 14	(2) 4" Casters; (2) 10" Wheels	45 lbs.	Each	563.00

\* GREENGUARD Certified. Overall Dimensions: 18 x 51.



## G MULTI-CART® 8-IN-1 CART

Has the ability to unfold into eight different configurations! Cuts moving time and effort by 50%. Can be made into a furniture dolly, two-wheel hand truck, storage/transport caddy, platform cart or a hi-stacker.

ID No.	Expanded Size	Capacity	Caster/ Wheel Type	Shpg. Wt.	Unit	Price
7 AVT-86201	32.25 x 17.25	500 lbs	(2) 8" No-Flat Trac Rear Wheels; (2) 4" Swivel Front Casters	26 lbs.	Each	250.95





## A STEEL BOOK CART

Mobilize your books, magazines or research collections. Sturdy steel all welded construction with four casters (two locking) for easy mobility. No assembly required. Manufacturer's limited lifetime warranty.

ID No.	Finish	W x D x H	Shpg. Wt.	Unit	Price
<b>Double Sided Book Cart</b> —Six shelves.					
1	SAF-5357SA	Sand	36" x 18½" x 43½"	68 lbs.	Each <del>692.00</del>
<b>Single Sided Book Cart</b> —Three shelves.					
2	SAF-5358SA	Sand	36" x 14½" x 43½"	46 lbs.	Each <del>526.00</del>

## B SCOOT™ BOOK CART

Perfect for use in libraries, schools or any work area with a large collection of books. All-steel construction with unique hole pattern design is accented by tubular steel legs. Four oversized casters for easy maneuverability. Black powder coat finish for durability. Manufacturer's limited lifetime warranty.

ID No.	Finish	W x D x H	Shpg. Wt.	Unit	Price
<b>Double Sided Cart</b> —Three 8" deep slanted shelves on each side of cart. 12" clearance between shelves. Includes a height-adjustable file pocket.					
3	SAF-5335BL *	Black	41¼" x 17¾" x 41¼"	73 lbs.	Each <del>506.00</del>
<b>Single Sided Cart</b> —Three 12½" deep slanted shelves. 12¼" space between shelves.					
4	SAF-5336BL *	Black	33" x 14¼" x 44¼"	60 lbs.	Each <del>409.00</del>

\* GREENGUARD Certified.



## C CARRY-ALL CART/MAIL CART

7" deep top basket can accommodate letter- or legal-size files with included adjustable file rods. Sturdy bottom basket with 4" raised sides. Heavy-duty metal tube and wire construction resists scratches and withstands constant use. Snaps together in minutes without tools. Shelf and basket height adjustable in 1" increments. Four 4" nylon casters. Manufacturer's limited five-year warranty.

ID No.	Finish	W x D x H	Shpg. Wt.	Unit	Price
5	ALE-MC3518SR	Silver	34¾" x 18" x 39½"	29 lbs.	Each <del>369.00</del>

## D THREE-TIER WIRE CART WITH BASKET

Sturdy and solid wire cart for mobile shelving needs. Includes four 4" casters (two locking). Black Anthracite finish for wet and dry usages. Shelves and baskets adjust in 1" increments. 500 lbs. total weight capacity. Easy to assemble- no tools required. Manufacturer's limited five-year warranty.

ID No.	Finish	W x D x H	Shpg. Wt.	Unit	Price
<b>Four 4" Casters</b> —Two wire shelves, one wire basket, three shelf liners, four 35" poles and one pull handle.					
6	ALE-SW543018BA *	Black Anthracite	34" x 18" x 40"	41 lbs.	Each <del>270.00</del>
<b>Four 3" Casters</b> —Two wire shelves, one wire basket, four poles and one pull handle.					
7	ALE-SW342416BA *	Black Anthracite	28" x 16" x 39"	26 lbs.	Each <del>179.00</del>

\* Meets or Exceeds ANSI/BIFMA Standards.

## E THREE-SHELF WIRE CART WITH LINERS

Three adjustable shelves with pull handle. Includes three shelf liners, four 35" poles and four casters (two locking). Shelves adjust in 1" increments. 500 lbs. total weight capacity on casters. Easy to assemble—no tools required. Manufacturer's limited five-year warranty.

ID No.	Finish	W x D x H	Shpg. Wt.	Unit	Price
8	ALE-SW333018SR *	Silver	34½" x 18" x 40"	27 lbs.	Each <del>249.00</del>
9	ALE-SW322416SR *	Silver	28½" x 16" x 39"	24 lbs.	Each <del>161.00</del>

\* Meets or Exceeds ANSI/BIFMA Standards.



**Fast Delivery**  
In most cases, the next business day!

# Office Furnishings Heaters



A



B



C



D



E



F



## A CERAMIC HEATER

Lightweight table-top heater for easy portability. Air is heated by an efficient ceramic heating element and circulated around the room by a fan. Adjustable thermostat up to 1500 watt heating output. Designed with safety in mind with overheat auto-shut off protection, tip-over safety switch, and a cool-to-the-touch plastic housing. Quiet heat or fan-only setting for all season use. Manufacturer's limited one year warranty.

ID No.	Color	W x D x H	Unit	Price
1 ALE-HECH09 *	Black	7 1/8" x 5 1/8" x 8 3/4"	Each	70.00

\* ETL Certified.

## Honeywell

## B DIGITAL CERAMIC MINI TOWER HEATER

Keeping warm has never been easier. Convenient heater has digital easy-touch controls and an easy-to-read LCD display. The programmable thermostat allows you to choose the right temperature for you. One-, two-, four-, and eight-hour settings keep you warm without constantly having to adjust the controls. Manufacturer's limited three-year warranty.

ID No.	Color	W x D x H	Unit	Price
2 HWL-HCE311V *	Black	10" x 7 1/2" x 14"	Each	82.67

\* ETL Listed.



## C MINI TOWER CERAMIC HEATER

Oscillating mini-tower heater delivers heat where you need it. Air is warmed as it passes over a large ceramic and aluminum heating element. Heat is dispersed by a powerful fan. Adjustable thermostat up to 1500 watt heating output for maximum comfort. Designed with safety in mind with overheat auto-shut off protection, tip-over safety switch, and a cool-to-the-touch plastic housing. Manufacturer's limited one-year warranty. ☒

ID No.	Color	W x D x H	Unit	Price
3 ALE-HECT17 *	Black	7 3/4" x 7 3/4" x 17 3/4"	Each	119.00

\* ETL Certified.

## D CERAMIC HEATER TOWER WITH REMOTE CONTROL

Oscillating tower heater is perfect to heat up your room or office. Air is warmed as it passes over a large ceramic and aluminum heating element providing more consistent and natural heat. Heat is dispersed by a powerful fan. Programmable digital thermostat can be set to your ideal temperature. Up to 1500-watt heating output at maximum performance. Auto-off timer up to 8 hours. Designed with safety in mind with overheat auto shut-off protection, tip-over switch, and cool-to-the-touch plastic housing. Includes remote control. Intergrated carry handle. Manufacturer's limited one-year warranty. ☒

ID No.	Color	W x D x H	Unit	Price
4 ALE-HECT24 *	Black	7.17" x 7.17" x 22.95"	Each	139.00

\* ETL Certified.

## E QUARTZ TOWER HEATER

Make your cold space comfortable quickly with this quiet tower heater. Glowing quartz-elements radiate heat directly forward for immediate warmth. Adjustable thermostat up to 1500 watt heating output. Designed with safety in mind with overheat auto-shut off protection, tip-over safety switch, and a cool-to-the-touch carry handle. Manufacturer's limited one-year warranty.

ID No.	Color	W x D x H	Unit	Price
5 ALE-HEQZ23 *	White	13 1/4" x 10 1/8" x 23 1/4"	Each	155.00

\* ETL Certified.

## F HEATER FAN

Compact heater provides heat just where you need it. Air is heated by a coiled metal heating element and circulated by a fan. Three way adjustable thermostat with up to 1500 watt heating output. Designed with safety in mind with overheat auto-shut off protection, tip-over safety switch, and a cool-to-the-touch plastic housing. Quiet heat or fan-only setting for all-season use. Manufacturer's limited one year warranty.

ID No.	Color	W x D x H	Unit	Price
6 ALE-HEFF10B *	Black	8 1/4" x 4 3/8" x 9 1/2"	Each	47.00

\* ETL Certified.



### A DIGITAL FAN-FORCED OSCILLATING HEATER

Oscillating heater gets warm air circulating to quickly heat up any small to mid-sized room. Digital thermostat to help set a precise temperature with up to 12-hour shut-off timer and two heat settings. Quiet heat or fan-only setting for all-season use. Designed with safety in mind, also features overheat auto-shut off protection, tip-over safety switch and a cool-to-the-touch plastic housing. Manufacturer's limited one-year warranty.

ID No.	Color	W x D x H	Unit	Price
1 ALE-HEFF12B *	Black	9¼" x 7" x 11¾"	Each	<del>107.00</del>

\* ETL Certified.

### B 360° CIRCULAR FAN FORCED HEATER

This 360-degree portable heater is ideal for providing all-around room warmth to any small to mid-sized room. Two different heat setting modes and an adjustable thermostat let you customize the temperature to your comfort. Designed with safety in mind with overheat auto-shut off protection, tip-over safety switch and a cool-to-the-touch plastic housing. Manufacturer's limited one-year warranty.

ID No.	Color	W x D x H	Unit	Price
2 ALE-HEFF360B *	Black	8" x 8" x 12"	Each	<del>92.00</del>

\* ETL Certified.

### E DIGITAL TOWER HEATER

Keep warm with minimal effort. Convenient heater has digital easy-touch controls and an easy-to-read LCD display. The programmable thermostat allows you to choose the right temperature for you. One-, two-, four-, and eight-hour settings keep you warm without constantly having to adjust the controls. Manufacturer's limited three year warranty.

ID No.	Color	W x D x H	Unit	Price
5 HWL-HCE322V *	Black	10¼" x 8" x 23¼"	Each	<del>109.11</del>

\* ETL Listed.

### F 360 SURROUND FAN FORCED HEATER

Features a 360-degree radius design that allows for superior all-around heating. This feature can easily be adjusted and redirected in the direction of your choosing. A fully adjustable thermostat is included and has been designed to be especially accessible and easy-to-read. The ability to navigate between two heat settings and the presence of a fan add even more flexibility to a heater that's inherently versatile. Offers numerous safety features, including tip-over switch, overheat protection and flame resistant construction. Manufacturer's limited three-year warranty.

ID No.	Color	W x D x H	Unit	Price
6 HWL-HHF360V *	Gray	9" x 9" x 12"	Each	<del>51.50</del>

\* ETL Listed.

## Honeywell

### C HEAT BUD PERSONAL HEATER

Low wattage personal heater provides a maximum of 250 watts of heat. Cool touch housing allows you to keep warm while the heater remains cool to the touch. Dual heat settings allow you to choose the level right for you.

ID No.	Color	W x D x H	Unit	Price
3 HWL-HCE100B *	Black	4¼" x 4.33" x 6½"	Each	<del>54.42</del>

\* ETL.

### D ENERGY SMART™ COOL TOUCH HEATER

Set and save your preferences to ensure the perfect temperature all winter long. Self-regulating unit manages electricity flow to provide precise thermostat control. Cool Touch housing helps keep you safe. Manufacturer's limited three-year warranty.

ID No.	Color	W x D x H	Unit	Price
4 HWL-HZ7304U *	White	11¼" x 8¾" x 12¾" x 10"	Each	<del>86.14</del>

\* ETL Listed.

### G ENERGY SMART™ HZ-970 QUARTZ-IRREDRANT HEATER

Make a cold room comfortable almost instantaneously with this ultra-quiet infrared quartz-element heater. Programmable thermostat, four timer settings and two continuous heat settings allow you to tailor operation to suit your preferences. Manufacturer's limited three-year warranty.

ID No.	Color	W x D x H	Unit	Price
7 HWL-HZ970 *	White	15¾" x 17¾" x 19¾"	Each	<del>207.43</del>

\* ETL Listed.

### H FILTER-FREE WARM MIST HUMIDIFIER

Quiet filter-free operation. Warm visible mist is 95% bacteria free. Essential oil tray. Manufacturer's three year warranty.

ID No.	Color	W x D x H	Unit	Price
8 HWL-HWM845B *	Black	11.95" x 7.45" x 12.45"	Each	<del>84.60</del>

\* ETL Approved.

Prices subject to change without notice.  
Visit our website for the latest pricing and product information.

# Office Furnishings Lamps & Lighting

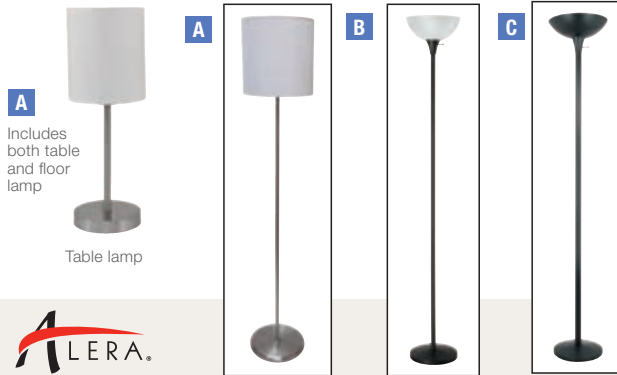

**A**  
Includes both table and floor lamp

Table lamp



Integrated USB charging port



ID	Key No.	Description	Height	Color	Plug	Standards	Light Bulb (incl.)	Price EA
<b>Contemporary Floor and Table Lamp Set</b>								
1	<b>A</b> LED-L9135 * ✕	Slim Line Lamp Set	61½"; 12¾"	Silver	2 Prong	ETL Certified	13W CFL	<del>195.00</del>
<b>Floor Lamps</b>								
2	<b>B</b> ALE-LMPF72B * ✕	Floor Lamp, Translucent Plastic Shade	71"	Matte Black	2 Prong	ETL Certified	3-Way 1 1/20/26W CFL	<del>115.00</del>
3	<b>C</b> ALE-LMPF52B * ✕	Torchiere Floor Lamp	72"	Matte Black	2 Prong	ETL Certified	3-Way 1 1/20/26W CFL	<del>125.00</del>
<b>Banker's Lamp</b>								
4	<b>D</b> ALE-LMP517AB * ✕	Banker's Lamp, Amber Shade w/USB Port	15"	Antique Brass	2 Prong	ETL Certified	13W CFL	<del>125.00</del>
5	<b>D</b> ALE-LMP537BZ * ✕	Banker's Lamp, Amber Shade	16"	Antique Bronze	2 Prong	ETL Certified	13W CFL	<del>102.00</del>
6	<b>D</b> ALE-LMP538BN * ✕	Banker's Lamp, White Shade	16"	Brushed Nickel	2 Prong	ETL Certified	13W CFL	<del>99.00</del>
7	<b>D</b> ALE-LMP557AB * ✕	Banker's Lamp, Green Shade	13"	Antique Brass	2 Prong	ETL Certified	13W CFL	<del>91.00</del>

\* LED-L9135—Manufacturer's three-year mechanical, one-year electrical warranty.  
 ALE-LMPF72B, ALE-LMPF52B, ALE-LMP517AB, ALE-LMP537BZ, ALE-LMP538BN, ALE-LMP557AB—Manufacturer's limited one-year warranty.

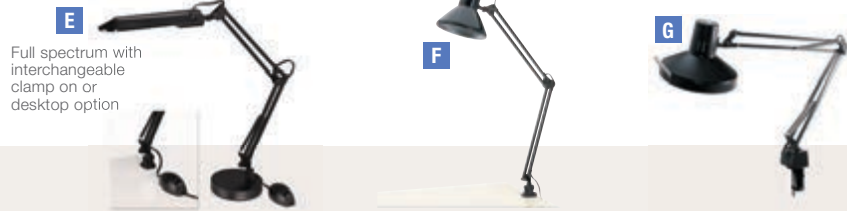

**E**  
Full spectrum with interchangeable clamp on or desktop option



ID	Key No.	Description	Height	Color	Plug	Standards	Light Bulb (incl.)	Price EA
<b>Adjustable Full Spectrum Fluorescent Desk Lamps</b>								
8	<b>E</b> ALE-LMPD28B * ✕	Full Spectrum "Daylight" Architect Lamp	25"	Matte Black	2 Prong	ETL Certified	13W CFL tube	<del>87.00</del>
<b>Adjustable Architect Style Desk Lamps</b>								
9	<b>F</b> ALE-LMP702B * ✕	Clamp-On Architect Lamp	28"	Black	2 Prong	ETL Certified	13W CFL	<del>64.00</del>
10	<b>G</b> LED-L445BK * ✕	Professional Combination Clamp-On Lamp	44½"	Black	3 Prong	ETL Listed	19W CFL, 25W circline fluorescent bulb	<del>109.00</del>
11	<b>G</b> LED-L445WT * ✕	Professional Combination Clamp-On Lamp	44½"	White	3 Prong	ETL Listed	19W CFL, 25W circline fluorescent bulb	<del>109.00</del>

\* ALE-LMPD28B, ALE-LMP702B—Manufacturer's limited one-year warranty.  
 LED-L445BK, LED-L445WT—Manufacturer's three-year mechanical, one-year electrical warranty.

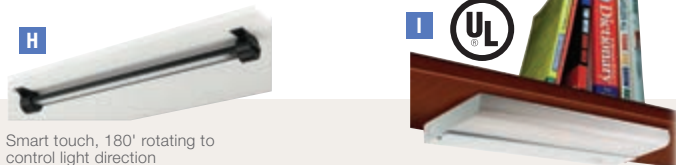

**H**  
Smart touch, 180° rotating to control light direction



ID	Key No.	Description	Height	Color	Plug	Standards	Light Bulb (incl.)	Price EA
<b>Under-Cabinet LED Lights</b> —Includes Mounting Tape and Screws.								
12	<b>H</b> ALE-LEDUC24B * ✕	Under-Cabinet LED Lamp	24" × 2"	Black	2 Prong	ETL Certified	4W LED	<del>86.00</del>
<b>Under-Cabinet Low Profile Fluorescent Lights</b>								
13	<b>I</b> LED-L9011 * ✕	Low-Profile Fluorescent Under-Cabinet Light Fixture	18¼" × 4"	White	2 Prong	UL Listed	15W T8 fluorescent tube	<del>44.28</del>

\* ALE-LEDUC24B—Manufacturer's limited one-year warranty.  
 LED-L9011—Manufacturer's three-year mechanical, one-year electrical warranty.





ID	Key	No.	Description	Height	Color	Plug Type	Standards	Light Bulb (incl.)	Price EA
<b>Adjustable Desk Lamps</b>									
1	A	ALE-LED900S *	Adjustable LED Task Lamp with USB Port	26"	Brushed Nickel	2 Prong	ETL Certified	LED	125.00
2	B	ALE-LED908B *	Adjustable LED Desk Lamp	21½"	Black	2 Prong	ETL Certified	36-piece LED Strip	98.00
3	C	ALE-LED931B *	LED Task Lamp	17"	Black	2 Prong	ETL Certified	3W LED	64.00
<b>Magnifier Desk Lamps</b>									
4	D	ALE-LEDM765B * ✕ ✕	Desk or Clamp LED Magnifier Lamp	16¾"	Black	2 Prong	ETL Certified	5.4W LEDs	99.00
5	E	ALE-LMPM745B * ✕ ✕	Full Spectrum Clamp-On Magnifier Lamp	36"	Matte Black	2 Prong	ETL Certified	22W Full Spectrum	139.00
<b>Adjustable Desk Lamps</b>									
6	F	ALE-LED902B *	LED Desk Lamp with Interchangeable Base or Clamp	21¾"	Black	2 Prong	ETL Listed	LED	91.00
7	G	ALE-LED912B *	Twin-Arm Task LED Lamp with USB Port	18½"	Black	2 Prong	ETL Certified	3W LED	91.00
<b>Adjustable Fluorescent Desk Lamps</b>									
8	H	LED-L9090 *	Advanced Style Gooseneck Desk Lamp	16½"	Black	2 Prong	ETL Certified	13W CFL	64.00
<b>Adjustable Halogen Desk Lamps</b>									
9	I	LED-L281MB * ✕ ✕	High-Output Halogen Desk Lamp	20¼"	Matte Black	2 Prong	ETL Listed	100W	217.59
<b>Adjustable Architect Style Desk Lamps</b>									
10	J	ALE-LMP603B * ✕ ✕	Architect Desk Lamp	22"	Black	2 Prong	ETL Certified	13W CFL	64.00
<b>Fluorescent Desk Lamps</b>									
11	K	LED-L563MB *	CFL Domed Desk Lamp	16¼"	Matte Black	2 Prong	ETL Certified	13W CFL	88.00
<b>Adjustable CFL Task Lamps</b>									
12	L	ALE-LMP832B *	Task Lamp	16"	Black	2 Prong	ETL Certified	13W CFL	52.00

\* ALE-LED900S, ALE-LED908B, ALE-LED931B, ALE-LED765B, ALE-LMPM745B, ALE-LED902B, ALE-LED912B, ALE-LMP603B, ALE-LMP832B—Manufacturer's limited one-year warranty.  
LED-L9090, LED-L281MB, LED-L563MB—Manufacturer's three-year mechanical, one-year electrical warranty.

# Office Furnishings Lamps & Lighting



imagination at work

ID	No.	Bulb Size	Appearance	Watts	Equiv. to Incandescent	Hours	Lumens	Qty.	Unit	Price
<b>Halogen—A19</b>										
1	A	GEL-67769	Reveal	29 W	40 W	1000 h	430 lm	4	Pack	19.03
2	A	GEL-67773	Reveal	53 W	75 W	1000 h	890 lm	4	Pack	19.03
3	A	GEL-67774	Reveal	72 W	100 W	1000 h	1270 lm	4	Pack	19.03
4	A	GEL-67770	Reveal	43 W	60 W	1000 h	430 lm	4	Pack	19.03
5	B	GEL-66247	Soft White	43 W	60 W	1000 h	620 lm	4	Pack	11.85
6	B	GEL-66249	Soft White	72 W	100 W	1000 h	1270 lm	4	Pack	11.85
7	B	GEL-66248	Soft White	53 W	75 W	1000 h	890 lm	4	Pack	11.38
<b>LED—A19</b>										
8	C	GEL-99190	Soft White	8 W	40 W	1000 h	760 lm	4	Pack	14.28
9	C	GEL-67615	Soft White	10 W	60 W	1500 h	800 lm	4	Pack	21.40
10	D	GEL-99192	Daylight	8 W	40 W	1000 h	760 lm	4	Pack	14.28
11	D	GEL-67616	Daylight	10 W	60 W	1500 h	800 lm	4	Pack	21.40
<b>Rough Service Incandescent—A21</b>										
12	E	GEL-18274	Inside Frost/Basic	75 W	....	1000 h	750 lm	1	Each	4.01
13	E	GEL-18275	Inside Frost/Basic	100 W	....	1000 h	1230 lm	1	Each	4.01
<b>Incandescent—A21</b>										
14	F	GEL-89371	Reveal	200 W	....	750 h	2395 lm	1	Each	7.21
<b>LED—A21</b>										
15	G	GEL-31181	Daylight	10 W	75 W	10000 h	1060 lm	2	Pack	16.80
16	G	GEL-31186	Daylight	13 W	100 W	10000 h	1520 lm	2	Pack	20.00
17	G	GEL-66117	Daylight	12 W	75 W	15000 h	1100 lm	2	Pack	19.80
18	G	GEL-66133	Daylight	15 W	100 W	15000 h	1600 lm	2	Pack	23.65
19	H	GEL-31180	Soft White	10 W	75 W	10000 h	1060 lm	2	Pack	16.80
20	H	GEL-31185	Soft White	13 W	100 W	10000 h	1520 lm	2	Pack	20.00
21	H	GEL-65943	Soft White	12 W	75 W	15000 h	1100 lm	2	Pack	19.88
22	H	GEL-65941	Soft White	15 W	100 W	15000 h	1600 lm	2	Pack	23.65
<b>3 Way Halogen—A21</b>										
23	I	GEL-97785	Reveal	50 W; 100 W; 150 W	....	1200 h	450 lm	1	Each	10.22
24	I	GEL-97494	Soft White, 3-Way	50 W; 100 W; 150 W	....	1200 h	615 lm	1	Each	6.67
<b>3 Way LED—A21</b>										
25	J	GEL-37656	Soft White	22 W	150 W	25000 h	2155 lm	1	Each	47.20



imagination at work

ID No.	Bulb Size	Appearance	Watts	Equiv. to Incandescent	Hours	Lumens	Qty.	Unit	Price
<b>Incandescent—BR30</b>									
1	A GEL-48692	Reveal	65 W	.....	2000 h	445 lm	1	Each	<del>21.00</del>
2	A GEL-20331	Soft White	65 W	.....	2000 h	610 lm	1	Each	<del>11.85</del>
3	A GEL-24705	Soft White	65 W	.....	2000 h	610 lm	6	Carton	<del>41.25</del>
<b>LED—BR30</b>									
4	B GEL-40893	Soft White	10 W	65 W	15000 h	700 lm	1	Each	<del>8.00</del>
<b>LED—GU10</b>									
5	C GEL-37114	Warm White	3.7 W	35 W	25000 h	260 lm	1	Each	<del>16.00</del>
<b>LED—PAR20</b>									
6	D GEL-93360	Warm Soft White	7 W	50 W	25000 h	500 lm	1	Each	<del>23.90</del>
<b>LED—PAR30</b>									
7	E GEL-42133	Warm White	12 W	75 W	25000 h	1000 lm	1	Each	<del>35.15</del>
8	E GEL-84379	Warm White	12 W	75 W	25000 h	750 lm	1	Each	<del>37.95</del>
<b>Halogen—PAR38</b>									
9	F GEL-66280	Crisp White	60 W	75 W	1100 h	1070 lm	2	Pack	<del>40.60</del>
10	F GEL-62706	Crisp White	90 W	120 W	1100 h	300 lm	1	Each	<del>23.48</del>
11	F GEL-66282	Crisp White	90 W	120 W	1100 h	1790 lm	2	Pack	<del>40.60</del>
<b>LED—PAR38</b>									
12	G GEL-92967	Warm White	18 W	150 W	25000 h	1400 lm	1	Each	<del>42.10</del>
13	G GEL-65731	Daylight	18 W	150 W	25000 h	1550 lm	1	Each	<del>37.95</del>
<b>Incandescent—S11</b>									
14	H GEL-35156	Clear	40 W	.....	500 h	440 lm	1	Each	<del>6.34</del>
<b>Halogen—T3</b>									
15	I GEL-34708	Clear	35 W	.....	2000 h	550 lm	1	Each	<del>17.00</del>

20-MF-L-FCL

# Office Furnishings Lecterns



**SAFCO**

## A - B LECTERNS

- Sturdy ¾" wood construction with stain-resistant laminate finish.
- Easy assembly with cam-lock fasteners.
- Manufacturer's limited lifetime warranty.
- Contains 80% total recycled content.

## A EXECUTIVE MOBILE LECTERN

Slanted reading surface with pencil tray and cushioned wrist support/paper stop. Pullout shelf slides left or right to hold equipment or notes. Curved shelves allow speaker to stand close to lectern. Easily mobile on four swivel casters (two locking). Open cabinet base. Manufacturer's limited lifetime warranty.

ID No.	Color	W × D × H	Shpg. Wt.	Unit	Price
1	SAF-8918MH ★ Mahogany	25¼" × 19¾" × 46"	98 lbs.	Each	819.00

★ Contains 80% total recycled content.

## B STAND-UP LECTERN

Lectern features sturdy ¾" wood construction with stain-resistant laminate finish. Slanted reading surface features pencil groove and paper stop. Height-adjustable storage shelf accommodates presentation materials. Easy assembly with cam-lock fasteners. Floor glides included. Manufacturer's limited lifetime warranty.

ID No.	Color	W × D × H	Shpg. Wt.	Unit	Price
2	SAF-8915MH ★ Mahogany	23" × 15¾" × 46"	55 lbs.	Each	390.00

★ Contains 80% total recycled content.

## C SCOOT™ MULTIPURPOSE LECTERN

Multipurpose lectern travels easily and adapts to a variety of situations. Fold-down platform offers a flat surface for media needs and easy visibility. Lectern features large open storage area underneath presentation surface, plus interior shelf with double doors. Shelves adjust in 1" increments. Two swivel cup holders. Powder-coated steel construction with durable laminate shelves. Mobile on four casters; two lock for added stability. Manufacturer's limited lifetime warranty.

ID No.	Color	W × D × H	Shpg. Wt.	Unit	Price
3	SAF-8922BL Black/Silver	28¾" × 22" × 49¾"	83 lbs.	Each	677.00

## D LAPTOP COMPUTER CADDY

Split top tilts for ergonomic use and has raised paper stops to prevent items from slipping off.

ID No.	Color	W × D × H	Shpg. Wt.	Unit	Price
4	MLN-950-ANT Anthracite	29½" × 20" × 38"	19 lbs.	Each	246.00
5	MLN-950-MEC Medium Cherry	29½" × 20" × 38"	19 lbs.	Each	246.00

## E ECONOMY MOBILE COMPUTER/PROJECTOR STAND

Locking cabinet for secure equipment storage. Scratch-resistant melamine finish. Ideal for projectors and laptops. Tilting, 18¼" w × 19¾" d projector shelf adjusts in 1" increments from 20" to 29" high and also features containment ridge. Removable 12" w × 17" d document shelf can be used on either side. Locking cabinet measures 18¼" w × 18½" d × 14¾" h. Open compartment below adjustable shelf for storage. Four casters (two locking). Manufacturer's limited lifetime warranty.

ID No.	Finish	W × D × H	Shpg. Wt.	Unit	Price
6	SAF-8927BL Black	19½" × 20½" × 30"	49 lbs.	Each	305.00

## F ADJUSTABLE-HEIGHT STEEL AV CART

Powder coated steel cart (for durability) holds up to a 20" monitor. Three 24 × 18" shelves, plus six-outlet UL approved mini-surge protector with power switch. Adjustable in 2" increments from 28½" to 36½" high. Ideal for media equipment. Four 4" Casters (2 Locking). Manufacturer's limited lifetime warranty.

ID No.	Finish	W × D × H	Shpg. Wt.	Unit	Price
7	SAF-8932BL ★ Black	27¼" × 18¼" × 36½"	58 lbs.	Each	418.00

★ GREENGUARD Certified; UL Approved.

**VERTIFLEX**

## G ADJUSTABLE MULTI-USE STORAGE CART AND STAND-UP WORKSTATION

Heavy-duty, metal construction with a removable MDF top tray. Center two baskets are adjustable in height. Can be configured with four bins as a standing laptop station, three bins for desk-side storage, or two bins for underdesk use. Rolls smoothly on four casters, two locking.

ID No.	Finish	W × D × H	Shpg. Wt.	Unit	Price
8	VRT-VF51025 Gray	16¼" × 11¾" × 39"	24 lbs.	Each	169.00

**ALERA.**

## H 3-IN-1 CART AND STAND

Clever all-in-one design can be used as a utility cart, monitor stand, and/or printer cart. Includes 3 shelves, stacking columns, drawer and casters which can be configured any way you need such as a 2 or 3-tier cart and/or a single or double-shelf stand. Accommodates printers up to 75 lbs. Four Casters (2 Locking); Four Padded Glides. Manufacturer's limited five-year warranty.

ID No.	Finish	W × D × H	Shpg. Wt.	Unit	Price
9	ALE-U3N1BL Black/Gray	21¾" × 13¾" × 24¾"	14 lbs.	Each	103.00





**A ROTARY DISPLAY**

Beautiful solid wood display rotates 360° for easy access to all materials. Scoop design allows maximum visibility and easy retrieval. Features 48 pockets. Manufacturer's limited lifetime warranty.

ID No.	Pockets	W x D x H	Color	Shpg. Wt.	Unit	Price
1 SAF-4335MH	48	17¾" x 17¾" x 49½"	Mahogany	94 lbs.	Each	1,050.00

**B STEEL ROTARY MAGAZINE RACK**

Four-sided rack rotates 360° for total access to all literature. Perfect for reception areas or waiting rooms. Floor standing, ships fully assembled. Manufacturer's limited lifetime warranty.

ID No.	Pockets	W x D x H	Color	Shpg. Wt.	Unit	Price
2 SAF-4325BL	92	14" x 14" x 68"	Black	107 lbs.	Each	906.00

\* GREENGUARD Certified.

**C ONYX™ MESH ROTATING MAGAZINE DISPLAY**

Ideal for reception areas or waiting rooms, this contemporary three-sided rack rotates 360° for total access to all literature. Features 1" capacity pockets. Sleek steel mesh construction. Has black powder coat finish for durability.

ID No.	Pockets	W x D x H	Color	Shpg. Wt.	Unit	Price
3 SAF-5577BL	30	16½" x 16½" x 66"	Black	44 lbs.	Each	414.00

\* GREENGUARD Certified.

**D ONYX™ MAGAZINE FLOOR RACK**

Sleek black steel mesh displays your literature in contemporary style. 2" capacity per pocket. Features powder coat finish for durability. Manufacturer's limited lifetime warranty.

ID No.	Pockets	W x D x H	Color	Shpg. Wt.	Unit	Price
4 SAF-6461BL	5	12½" x 18½" x 46"	Black	13 lbs.	Each	97.00

\* GREENGUARD Certified.

**E WIRE ROTARY DISPLAY RACKS**

Clean, open-wire look allows for a full-front view of literature. Layers rotate independently for easy literature selection. Five dual-wheel casters (two locking). Disassembles and reassembles quickly. Ideal for trade shows. Welded wire construction with a powder coated finish. Manufacturer's limited lifetime warranty.

ID No.	Pockets	W x D x H	Color	Shpg. Wt.	Unit	Price
5 SAF-4128CH	32	15" x 15" x 60"	Charcoal	21 lbs.	Each	319.00
6 SAF-4139CH	16	15" x 15" x 60"	Charcoal	18 lbs.	Each	319.00

**Brochure Size**—4½w x 1d compartments display brochures, pamphlets and other literature.

**Literature Size**—Letter size compartments are 1½" deep.

\* GREENGUARD Certified.



**F LITERATURE FLOOR DISPLAY RACK**

The combination of metal and plastic offers a unique and elegant design, with clean and updated lines. Compartments provide immediate identification of documents. Large base with non-slip pads offers extreme stability. Manufacturer's one-year warranty.

ID No.	Pockets	W x D x H	Color	Shpg. Wt.	Unit	Price
7 ABA-DDEXPO6	6	13¾" x 19¾" x 36¾"	Silver Gray/Black	19 lbs.	Each	344.00
8 ABA-DDEXPO8	16	23" x 19¾" x 36¾"	Silver Gray/Black	24 lbs.	Each	399.00

**Straight Top On Each Compartment; Holds 400 Sheets Per Compartment**

**Straight Top On Each Compartment; Holds 800 Sheets Per Compartment (Two Stacks Of 400 Sheets)**

**G MOBILE LITERATURE DISPLAY**

Clear display allows for easy, immediate identification of documents. Display is designed with an elliptical structure and four roller casters, including two with brakes, ensuring great mobility and making it easy to display documents and magazines wherever you want them. Large capacity compartments hold up to 350 sheets per compartment. Manufacturer's one-year warranty.

ID No.	Pockets	W x D x H	Color	Shpg. Wt.	Unit	Price
9 ABA-DD5PM	5	13¾" x 20¼" x 65¾"	Silver Gray/Black	18 lbs.	Each	344.00



**Fast Delivery**  
In most cases, the next business day!

Prices subject to change without notice. Visit our website for the latest pricing and product information.

# Office Furnishings Literature Racks & Displays/Floor & Wall



## A ONYX™ MESH LITERATURE RACK

A contemporary look in magazine racks that will fit into any setting. Perfect for use in a front office, reception area or work area for keeping literature close at hand. Wall mounting hardware included. Features black powder coat finish for durability.

ID No.	Pockets	W x D x H	Color	Shpg. Wt.	Unit	Price
1 SAF-5578BL *	5	10¼" x 3½" x 28"	Black	5 lbs.	Each	94.00
2 SAF-5579BL *	10	10¼" x 3½" x 50¾"	Black	6 lbs.	Each	149.00

\* GREENGUARD Certified.

## B SOLID WOOD WALL-MOUNT LITERATURE DISPLAY RACK

Solid wood sides and hardboard dividers and back make this magazine display durable and perfect for any work environment. Scoop front pockets allow maximum visibility and easy access. Mounting hardware included. Manufacturer's limited lifetime warranty.

ID No.	Pockets	W x D x H	Color	Shpg. Wt.	Unit	Price
3 SAF-4330MH	5	11¼" x 3¾" x 23¾"	Mahogany	9 lbs.	Each	153.00
4 SAF-4331MH	12	11¼" x 3¾" x 48¾"	Mahogany	18 lbs.	Each	246.00

## C STEEL MAGAZINE RACK

Solid steel with an attractive design on the pockets. Mounts to wall or can be used with optional gray base—Saftco® Steel Base for Magazine Rack (sold separately). Durable textured powder coat finish. Manufacturer's limited lifetime warranty.

ID No.	Pockets	W x D x H	Color	Shpg. Wt.	Unit	Price
5 SAF-4321BL *	11	10" x 4" x 36¼"	Black	11 lbs.	Each	157.00
6 SAF-4321GR *	11	10" x 4" x 36¼"	Gray	11 lbs.	Each	157.00
7 SAF-4322BL *	23	10" x 4" x 65½"	Black	27 lbs.	Each	227.00
8 SAF-4322GR *	23	10" x 4" x 65½"	Gray	27 lbs.	Each	227.00

\* GREENGUARD Certified.

## D EXPOSE™ ADJUSTABLE MAGAZINE/PAMPHLET LITERATURE DISPLAY

Rich wood finish adds style to any workspace. Crystal clear plastic front panel provides a full view of materials in each pocket. Removable dividers allow you to use each compartment to display a magazine or two pamphlets. Mounting hardware included. Manufacturer's limited lifetime warranty.

ID No.	Pockets	W x D x H	Color	Shpg. Wt.	Unit	Price
9 SAF-5702MH	9	29¾" x 2½" x 38¼"	Mahogany	22 lbs.	Each	416.00

**Magazine/Pamphlet Size Combination**—Holds 9 Magazines or 18 Pamphlets.

## E LUXE™ MAGAZINE & PAMPHLET DISPLAY

Sleek designed display with silver-coated, brushed aluminum frame and clear acrylic pockets. Wall-mounted and floor-standing racks have center dividers that allow for pockets to be sized for magazines or pamphlets. Manufacturer's limited lifetime warranty.

ID No.	Pockets	W x D x H	Color	Shpg. Wt.	Unit	Price
10 SAF-4133SL *	3	31¾" x 5" x 15¼"	Clear/Silver	5 lbs.	Each	130.00

\* GREENGUARD Certified.

## F REVEAL™ CLEAR LITERATURE DISPLAYS

Unobtrusive, break-resistant, clear plastic displays blend into any office environment. Each pocket holds up to 1¾" of material. New front panel design features easy-to-clean opening. One-piece units require no assembly. Wall mounting hardware included. Manufacturer's limited lifetime warranty.

ID No.	Pockets	W x D x H	Color	Shpg. Wt.	Unit	Price
<b>6 Magazine Display</b>						
11 SAF-5607CL *	6	30" x 2" x 24½"	Clear	7 lbs.	Each	288.00
<b>9 Magazine Display</b>						
12 SAF-5603CL *	9	30" x 2" x 36¾"	Clear	10 lbs.	Each	386.00
<b>12 Magazine Display</b>						
13 SAF-5602CL *	12	30" x 2" x 49"	Clear	15 lbs.	Each	433.00
<b>3 Magazine, 6 Pamphlet Display</b>						
14 SAF-5605CL *	9	30" x 2" x 22½"	Clear	7 lbs.	Each	283.00
<b>6 Magazine, 12 Pamphlet Display</b>						
15 SAF-5600CL *	18	30" x 2" x 45"	Clear	14 lbs.	Each	422.00
<b>6 Pamphlet, 6 Magazine Display</b>						
16 SAF-5603CL *	12	30" x 2" x 34¾"	Clear	10 lbs.	Each	372.00
<b>8 Pamphlet Display</b>						
17 SAF-5608CL *	8	20½" x 2" x 20½"	Clear	5 lbs.	Each	241.00
<b>12 Pamphlet Display</b>						
18 SAF-5604CL *	12	30" x 2" x 20¼"	Clear	6 lbs.	Each	261.00
<b>24 Pamphlet Display</b>						
19 SAF-5601CL *	24	30" x 2" x 41"	Clear	13 lbs.	Each	416.00

\* GREENGUARD Certified.



## G WALL LITERATURE DISPLAY

Elegant solid wall display with an original combination of steel and acrylic materials. Great visibility of documents thanks to the translucent compartments. This wall-mounted display holds up to 300 sheets per compartment. Manufacturer's one-year warranty.

ID No.	Pockets	W x D x H	Color	Shpg. Wt.	Unit	Price
20 ABA-DDICE5M	5	13" x 3½" x 28½"	Silver Gray/Translucent	17 lbs.	Each	160.00



## Special Orders

Don't see it here?  
Just ask.



**A BAMBOO SUGGESTION BOXES**

Get suggestions, ideas and recommendations with a look that's natural to every environment. Clear acrylic display allows a customized message with a 8½" x 5½" display. Side compartment stores pens and suggestion cards. Lockable and includes two keys. Includes two keys and 25 suggestion cards. Slot Size: 5" x ¼".

ID No.	Color	W x D x H	Unit	Price
1 SAF-4237CY	Cherry	10" x 8" x 14"	Each	97-00
2 SAF-4237NA	Natural	10" x 8" x 14"	Each	97-00

**B STEEL SUGGESTION/KEY DROP BOX**

Box locks to secure contents and ensure confidentiality. Built-in pockets to hold comment cards, pens and supplies. Adhesive labels: "Suggestions", "Comments", "Key Drop" and "Express Check Out" provide an easy way to dedicate box for specific use. 1" diameter key drop. Includes suggestion box, two keys, pack of 25 suggestion cards and mounting hardware. Slot Size: 4¾" x ¼".

ID No.	Color	W x D x H	Unit	Price
3 SAF-4232BL	Black Powder Coat Finish	7" x 6" x 8½"	Each	77-00

★ GREENGUARD Certified.

**C INTEROFFICE MAILBOX**

The wall-mount design and solid steel construction of this interoffice mailbox brings convenience, anonymity and security to the workplace. The drop slot opening is located on the top of the mailbox and measures 10 ½" W x ¾" D; allowing it to accept letter-size documents, standard envelopes, memos, discs, CD-ROMs and more. The drop box includes a lock and two keys to deter unauthorized access, making it ideal for securely collecting interoffice mail, outgoing mail, reports, payments due and employee feedback. Great for offices, mailrooms, mail centers, retail stores, break areas and other areas where information and mail needs to be collected. Manufacturer's limited lifetime warranty.

ID No.	W x D x H	Slot Size	Color	Unit	Price
4 SAF-4258BL	12" x 3" x 12"	10½" x ¾"	Black	Each	76-00
5 SAF-4259BL	18" x 7" x 18"	10½" x ¾"	Black	Each	109-00

★ GREENGUARD Certified.

**D ONYX™ MESH COLLECTION BOX**

Collection box is wall mountable and features a locking lid to securely protect contents. Can be used as a drop box, deposit box, prize drawing box and more. Constructed of sturdy steel mesh construction with durable powder coat finish. Locking lid to securely protect contents and has front compartment for small item storage. Includes mounting hardware. Slot Size: 7" x 8½".

ID No.	Color	W x D x H	Unit	Price
6 SAF-4238BL	Black	7¼" x 8½" x 6"	Each	60-00



**E SUGGESTION BOX LITERATURE HOLDER WITH LOCKING TOP**

Durable suggestion box can be set on a countertop or wall mounted. Locked lid secures suggestions or sensitive material. Built-in 4½ x 3 pocket for suggestion cards or envelopes. Mounting hardware included. Includes lock, two keys and mounting hardware. Slot Size: 5½"W x ½"H.

ID No.	Color	W x D x H	Unit	Price
7 DEF-79803	White	13¾" x 3¾" x 13¼"	Each	75-48

**F OUTDOOR LITERATURE BOX**

This sleek, break-resistant outdoor box with a clear, visible front holds letter, legal and A4 documents. Thoughtful design and included mounting hardware provide a variety of mounting options to wooden posts, metal and plastic poles and various wall surfaces. Weatherproof and fade-resistant with a black self-closing lid and stay-closed tabs.

ID No.	Pockets	W x D x H	Color	Shpg. Wt.	Unit	Price
8 DEF-790901	1	10" x 4½" x 13¼"	Clear/Black	2 lbs.	Each	31-95



# Office Furnishings Literature Organizers

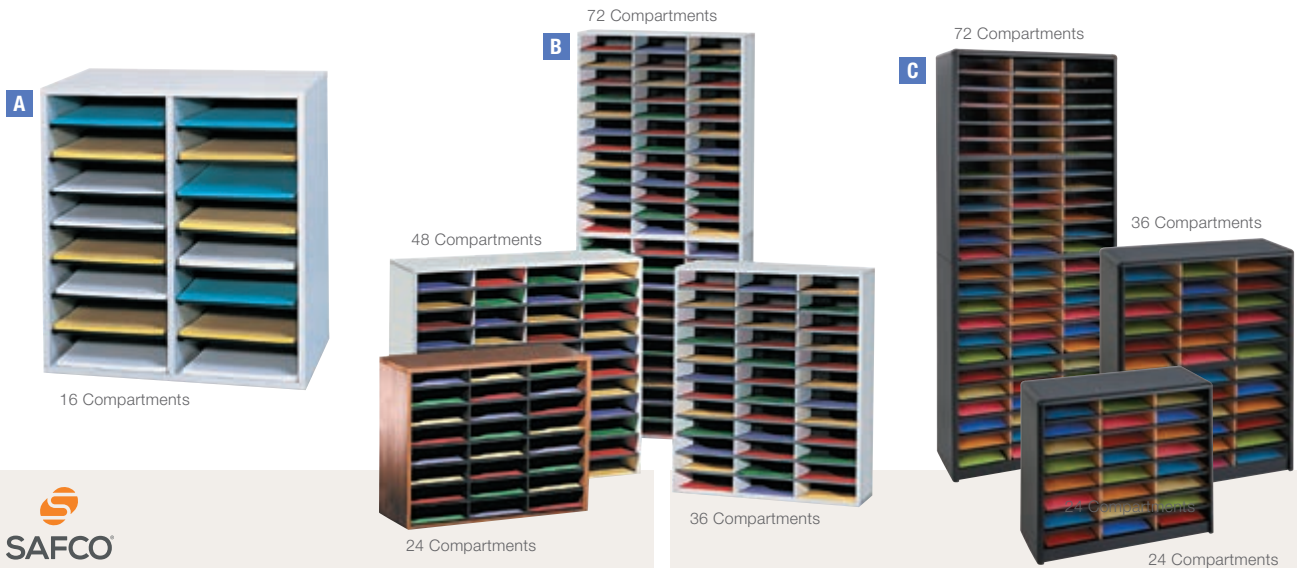

## A ADJUSTABLE COMPARTMENT WOOD LITERATURE ORGANIZERS

Cabinet is 5/8" compressed wood with laminate finish. Shelves form 9"w x 11 1/2"d x 2 1/4"h letter-size compartments, adjustable in 2 1/2" increments. Black plastic molding complements finish and doubles as a convenient labeling area (labels included). Each hardboard shelf holds up to 15 lbs. Mix and match stackable units. Solid fiberboard back. Manufacturer's limited lifetime warranty.

ID No.	Number of Compartments	W x D x H	Color	Unit	Price
1 SAF-9422GR	16	19 1/2" x 11 3/4" x 21"	Gray	Each	147.00
2 SAF-9422MO	16	19 1/2" x 11 3/4" x 21"	Medium Oak	Each	147.00
3 SAF-9423GR	24	39 1/4" x 11 3/4" x 16 1/4"	Gray	Each	186.00
4 SAF-9423MO	24	39 1/4" x 11 3/4" x 16 1/4"	Medium Oak	Each	186.00
5 SAF-9424GR	36	39 1/4" x 11 3/4" x 24"	Gray	Each	227.00
6 SAF-9424MO	36	39 1/4" x 11 3/4" x 24"	Medium Oak	Each	227.00



## B LITERATURE ORGANIZERS

Keep sales literature, mail and forms organized. Corrugated divider system with high-strength frame. Fast, easy assembly. Includes plastic finishing channels and self-adhesive labels. Manufacturer's limited lifetime warranty.

ID No.	Number of Compartments	W x D x H	Color	Unit	Price
<b>Compartment Size: 9w x 11 1/2d x 2 1/4h</b>					
7 FEL-25041	24	29" x 11 7/8" x 23 1/8"	Dove Gray	Each	149.99
8 FEL-25043	24	29" x 11 7/8" x 23 1/8"	Medium Oak	Each	149.99
9 FEL-25061	36	29" x 11 7/8" x 34 1/8"	Dove Gray	Each	207.99
10 FEL-25081	48	38 1/4" x 11 7/8" x 34 1/8"	Dove Gray	Each	270.29
11 FEL-25121	72	29" x 11 7/8" x 69 1/8"	Dove Gray	Each	367.99



## D LITERATURE ORGANIZER

Made entirely of recycled plastic. Letter size documents or literature can be stored in one of the 12 9" x 12" x 2" compartments. Each compartment features a convenient label holder to easily identify its contents. Holds over 60 lbs. Simple assembly requires no tools. Manufacturer's 90-day warranty.

ID No.	Number of Compartments	W x D x H	Color	Unit	Price
15 STX-61602U01C	12	31 3/8" x 13 3/8" x 10 5/8"	Black	Each	191.32
16 STX-61601U01C	12	31 3/8" x 13 3/8" x 10 5/8"	Gray	Each	191.32

Contains 100% post-consumer recycled material.



## C VALUE SORTER® LITERATURE ORGANIZERS

Steel shell and support shelves add stability and durability. Letter size, 9 3/4w x 12 1/2d x 2 1/2h compartments are made from heavy-duty corrugated fiberboard. Wide shelf front serves as label area (labels included). Easy assembly with quick-locking fasteners. Manufacturer's limited lifetime warranty.

ID No.	Number of Compartments	W x D x H	Color	Unit	Price
12 SAF-7111BL	24	32 1/4" x 13 1/2" x 25 3/4"	Black	Each	246.00
13 SAF-7121BL	36	32 1/4" x 13 1/2" x 38"	Black	Each	285.00
14 SAF-7131BL	72	32 1/4" x 13 1/2" x 75"	Black	Each	490.00



## E VERTICAL DESKTOP SORTER

Compact sorter with removable shelves only during assembly so you can customize the compartments. Ten hardboard shelves form up to eleven 9 1/2w x 11 1/2d x 1 1/4h letter-size compartments and support up to 15 lbs. each. Made of 1/2" compressed wood with laminate finish; solid fiberboard back. Manufacturer's limited lifetime warranty.

ID No.	Number of Compartments	W x D x H	Color	Unit	Price
17 SAF-9419CY	11	10 3/4" x 12" x 16"	Cherry	Each	87.00
18 SAF-9419GR	11	10 3/4" x 12" x 16"	Gray	Each	87.00
19 SAF-9419MO	11	10 3/4" x 12" x 16"	Medium Oak	Each	87.00





**Fellowes**

### A STEEL MAIL CART

Ideal for high-volume deliveries. Top basket holds legal size hanging file folders while the bottom shelf holds bulk mail or packages. Includes twin wheel front casters and large rear wheels. Rugged steel construction ensures durability. 200 lb. total cart weight capacity. Product is 100% recyclable. 4" front wheels; 6" rear wheels. Manufacturer's limited one-year warranty.

ID No.	Finish	W x D x H	Shpg. Wt.	Unit	Price
<b>150-FOLDER CAPACITY</b>					
1	FEL-40922	Dove Gray	20" x 40½" x 39"	49 lbs.	Each 586.59
<b>75-FOLDER CAPACITY</b>					
2	FEL-40924	Dove Gray	20" x 25½" x 39"	36 lbs.	Each 431.29

**SAFCO**

### D WIRE UTILITY CART

Transport and store materials safely and efficiently with wire utility carts. Each shelf holds up to 200 lbs. Shelves conveniently adjust in 1" increments. Rolls smoothly on four 3" nylon casters. Plastic liners for each shelf help prevent contents from being damaged. Manufacturer's limited lifetime warranty.

ID No.	Finish	W x D x H	Shpg. Wt.	Unit	Price
<b>TWO SHELF CART</b>					
7	SAF-5337BL	Black	43¾" x 19¼" x 40½"	29 lbs.	Each 212.00

★ GREENGUARD Certified.

**SAFCO**

### B SCOOT™ MAIL CART

All-steel construction with convenient handle and side storage pocket. Top basket holds legal-size folders. Bottom shelf with lip holds packages and supplies. 300 lb. capacity. Two 3" front casters, two 8" oversized rear wheels. Manufacturer's limited lifetime warranty.

ID No.	Finish	W x D x H	Shpg. Wt.	Unit	Price
<b>32" WIDE MAIL CART; HOLDS 150 LEGAL FILE FOLDERS</b>					
3	SAF-5239BL	Black/Silver	22½" x 39½" x 40¾"	55 lbs.	Each 555.00
<b>20" WIDE MAIL CART; HOLDS 75 LEGAL FOLDERS</b>					
4	SAF-5238BL	Black/Silver	22" x 27" x 40½"	44 lbs.	Each 399.00

★ GREENGUARD Certified.

### C WIRE MAIL CART

Heavy-duty steel, welded wire construction. Top basket holds legal-size hanging folders. Convenient dual handles. Bottom shelf for bulk mail and parcels. Mobile on four 4" casters (two locking). Manufacturer's limited lifetime warranty.

ID No.	Finish	W x D x H	Shpg. Wt.	Unit	Price
<b>36" WIDE CART; HOLDS 150 LEGAL FOLDERS</b>					
5	SAF-5236GR	Metallic Gray	39" x 18¾" x 38½"	47 lbs.	Each 466.00
<b>24" WIDE CART; HOLDS 75 LEGAL FOLDERS</b>					
6	SAF-5235GR	Metallic Gray	26¾" x 18¾" x 38½"	40 lbs.	Each 376.00

★ GREENGUARD Certified.

**Fellowes**

### E WIRE MAIL CART

Top basket with adjustable guides holds up to 150 letter or legal files. Bottom shelf for bulk mail or packages. Twin-wheel front casters and large rear wheels. Chrome-plated steel wire construction. 200 lb. capacity. 4" front swivel casters, 6" rear wheels. Manufacturer's limited one-year warranty.

ID No.	Finish	W x D x H	Shpg. Wt.	Unit	Price
8	FEL-40912	Chrome	21½" x 37½" x 39½"	25 lbs.	Each 574.99

**ALERA.**

### F CARRY-ALL CART/MAIL CART

7" deep top basket can accommodate letter- or legal-size files with included adjustable file rods. Sturdy bottom basket with 4" raised sides. Heavy-duty metal tube and wire construction resists scratches and withstands constant use. Snaps together in minutes without tools. Shelf and basket height adjustable in 1" increments. Four 4" nylon casters. Manufacturer's limited five-year warranty.

ID No.	Finish	W x D x H	Shpg. Wt.	Unit	Price
9	ALE-MC3518SR	Silver	34¾" x 18" x 39½"	29 lbs.	Each 369.00

Prices subject to change without notice. Visit our website for the latest pricing and product information.

# Office Furnishings Paper Towel & Dispensers/Restroom Supplies



## A PERSONAL SEAT COVER DISPENSER

Push lever dispenses one seat cover at a time. Replaceable lock with push-button option. Key guard prevents theft (key included). Simplified door hinge for easier filling. Mounting screws included. For use with KCC-07410PK; KCC-07410CT.

ID No.	Color	W × D × H	Qty.	Unit	Price
<b>Box</b>					
1	KCC-09506 ★	Black	17½" × 2¼" × 13¼"	1	Each <del>64.09</del>
2	KCC-09505 ★	White	17½" × 2¼" × 13¼"	1	Each <del>55.46</del>

★ When installed properly this dispenser meets the ADA Standards for Accessible Design, 28 CFR Part 36, local rules may vary.

## B PERSONAL SEATS TOILET SEAT COVERS

Flushable for sanitary protection. Fits Kimberly-Clark Professional\* Personal Seats Dispensers (sold separately).

ID No.	Color	W × D	Qty.	Unit	Price
3	KCC-07410CT ★	White	15" × 18"	24	Carton <del>207.99</del>

★ Contains 20% post-consumer recycled content, 50% total recycled content.



## G TOILET SEAT COVER DISPENSER

The optimal solution for any size washroom. Users simply dispense one seat cover, use and flush. Refills are also quick, convenient and easy. For use with Tork® TC0020.

ID No.	Color	W × D × H	Qty.	Unit	Price
11	TRK-99A	White	16" × 3" × 11½"	12	Carton <del>355.29</del>
12	TRK-1951001	Smoke	16" × 3.125" × 11.5"	12	Carton <del>288.00</del>

## H TOILET SEAT COVER

Toilet seat cover has a half-fold design and is easily dispensable with its ready-for-use design. Place it over toilet seats for more hygiene in the washroom or restroom and to protect users from cross contamination. Made from ABS plastic.

ID No.	Color	W × D	Qty.	Unit	Price
13	TRK-TC0020	White	14.5" × 17"	20	Carton <del>251.27</del>

## boardwalk

### C PREMIUM TOILET SEAT COVERS

Half-fold covers fit all popular seat cover dispensers. 250 covers per sleeve.

ID No.	Color	W × D	Qty.	Unit	Price
4	BWK-K1000	White	14¼" × 16½"	1000	Carton <del>22.52</del>
5	BWK-K2500	White	14¼" × 16½"	2500	Carton <del>52.92</del>
<b>Value Pack</b> —Stock up and save!					
6	BWK-K5000	White	14¼" × 16½"	5000	Carton <del>90.00</del>

## boardwalk

### I BOARDWALK® GREEN BATHROOM TISSUE

Embossed design for added bulk and softness. Absorbent and economical. Delivers value and performance. Individually wrapped to ensure sanitary protection.

ID No.	Ply	No. of Tissues	W × L	Qty.	Unit	Price
14	BWK-55GREEN ★	2	500 per roll	4" × 3.75"	80	Carton <del>99.49</del>
15	BWK-26GREEN ★	2	500 per roll	4" × 3.75"	96	Carton <del>112.39</del>

★ **BWK-55GREEN**—EcoLogo Certified; Green Seal Certified; EPA Compliant; LEED Applicable. Contains a minimum of 25% post-consumer recycled content, 100% total recycled content.  
 ★ **BWK-26GREEN**—EcoLogo Certified; EPA Compliant; LEED Applicable. Contains a minimum of 20% post-consumer recycled content, 100% total recycled content.

### J TWO-PLY TOILET TISSUE

The economical choice for quality bathroom tissue. Embossed, standard size roll.

ID No.	Ply	No. of Tissues	W × L	Qty.	Unit	Price
16	BWK-6144 ★	2	500 per roll	4" × 3.75"	96	Carton <del>75.61</del>

#### 125 foot Roll Length

17	BWK-6180 ★	2	500 per roll	4" × 3.75"	96	Carton <del>106.94</del>
----	------------	---	--------------	------------	----	--------------------------

#### 156.25 foot Roll Length

18	BWK-6150 ★	2	500 per roll	4" × 3.75"	96	Carton <del>135.89</del>
----	------------	---	--------------	------------	----	--------------------------

★ **BWK-6144, BWK-6150**—Contains 65% total recycled content.  
 ★ **BWK-6180**—Contains 55% post-consumer recycled content, 90% total recycled content.

### K ONE-PLY TOILET TISSUE

Embossed, facial quality bathroom tissue.

ID No.	Ply	No. of Tissues	W × L	Qty.	Unit	Price
19	BWK-6170 ★	2	500 per roll	4" × 3.75"	96	Carton <del>123.57</del>

★ Contains 20% pre-consumer recycled content, 80% post-consumer recycled content, 100% total recycled content.

### L OFFICE PACKS STANDARD BATHROOM TISSUE

In convenient quantities, just right for any office. Packaged for easy transport, dispensing and storage. Soft and absorbent. Whiteners without chemicals containing chlorine.

ID No.	Ply	No. of Tissues	W × L	Qty.	Unit	Price
20	BWK-6156 ★	2	500 per roll	4" × 3.75"	80	Carton <del>108.16</del>

★ Contains 60% post-consumer recycled content, 100% total recycled content.



## D HEALTH GARDS LEVER ACTION SEAT COVER DISPENSER

Deliver a single, ready-to-use, sanitary paper cover with the touch of a fingertip. No unfolding, no tabs to tear, just easier to use and cleaner restrooms. For use with HOSHG3000C.

ID No.	Color	W × D × H	Qty.	Unit	Price
7	HOS-HG3L	White	17.11" × 2.24" × 12.47"	1	Each <del>49.00</del>

## E EVOGEN NO TOUCH TOILET SEAT COVERS

This premium seat cover is presented from the dispenser in full and ready to use—not folded and no tabs to tear.

ID No.	Color	W × D	Qty.	Unit	Price
8	HOS-EVNT3000	White	15½" × 9¼"	3000	Carton <del>120.32</del>

## F HEALTH GARDS® TOILET SEAT COVERS

A cost effective, sanitary method of meeting personal hygiene needs in public restrooms. 250 covers per sleeve.

ID No.	Color	W × D	Qty.	Unit	Price
9	HOS-HG-5000CT	White	14¼" × 16½"	5000	Carton <del>115.05</del>

**Lever Dispenser Packs**—Fits virtually all lever-cover dispensers.

10	HOS-HG3000C	White	15" × 17"	3000	Carton <del>104.96</del>
----	-------------	-------	-----------	------	--------------------------

# Paper Towel & Dispensers/Standard Roll Tissue Office Furnishings



## A ESSENTIAL 100% RECYCLED FIBER SRB

Strong and absorbent. Provides home-like comfort at your business. Meets EPA standards; EcoLogo® certified.

ID No.	Ply	No. of Tissues	W x L	Qty.	Unit	Price
1 KCC-13217 *	2	506 per roll	4" x 4"	80	Carton	<del>100.29</del>

\* Contains 75% post-consumer recycled content, 100% total recycled content.

## B ESSENTIAL CORELESS SRB BATHROOM TISSUE

Made with 100% recycled fiber. Meets EPA standards for minimum post consumer waste content.

ID No.	Ply	No. of Tissues	W x L	Qty.	Unit	Price
2 KCC-04007 *	2	1000 per roll	4" x 3 3/4"	36	Carton	<del>126.69</del>

\* Contains 50% post-consumer recycled content, 65% total recycled content.

## C ESSENTIAL STANDARD ROLL BATHROOM TISSUE

The practical choice for bath tissue, offering the ideal blend of great performance and value. The product of choice for customers needing a highly efficient, long lasting, quality product. This product is made from wood that came from a certified managed forest.

ID No.	Ply	No. of Tissues	W x L	Qty.	Unit	Price
3 KCC-04460 *	2	550 per roll	4 1/4" x 4"	80	Carton	<del>102.00</del>

### For Traditional Business

4 KCC-13607 *	2	550 per roll	4 1/4" x 4"	20	Carton	51.75
---------------	---	--------------	-------------	----	--------	-------

\* Contains 40% post-consumer recycled content, 100% total recycled content.  
KCC-13607—Meets EPA Standards for Minimum Post-Consumer Waste Content; EcoLogo Certified. Convenience Carton.

## D PRO SMALL CORE HIGH CAPACITY (SRB)

This high-capacity, small core single roll bath tissue product fits into signature brand dispensers and many other high-capacity dispensers, making it a versatile and adaptable solution for your restroom needs. For Use With: High Capacity Standard Roll Bath Tissue Dispensers.

ID No.	Ply	No. of Tissues	W x L	Qty.	Unit	Price
5 KCC-47305 *	2	1100 per roll	3.9" x 3.7"	36	Carton	<del>131.34</del>

\* ASTM Certified Compostable; EPA Compliant; EcoLogo Certified; LEED Applicable. Contains 40% post-consumer recycled content, 40% total recycled content.

## E ESSENTIAL™ EXTRA SOFT CORELESS STANDARD ROLL BATH TISSUE

A premium coreless bath tissue with high capacity features. This product is made from wood that came from a certified managed forest.

ID No.	Ply	No. of Tissues	W x L	Qty.	Unit	Price
6 KCC-07001 *	2	800 per roll	4" x 4"	36	Carton	<del>124.54</del>

\* Contains 20% post-consumer recycled content, 25% total recycled content.



## F CLEAN CARE BATHROOM TISSUE

A premium bath tissue with unmatched, cushiony softness. Luxurious bath tissue for a premium image. This product is made from wood that came from a certified managed forest.

ID No.	Ply	No. of Tissues	W x L	Qty.	Unit	Price
7 KCC-12456	1	170 per roll	4 1/2" x 4"	48	Carton	79.42

## G PROFESSIONAL BATHROOM TISSUE

Delivers the quality and performance you know and trust, along with the confidence that the raw materials are sourced to the highest standards. This product is made from wood that came from a certified managed forest.

ID No.	Ply	No. of Tissues	W x L	Qty.	Unit	Price
8 KCC-13135 *	2	451 per roll	4 1/4" x 4"	20	Carton	52.35

**Value Pack**—Stock up and save!

9 KCC-17713 *	2	451 per roll	4 1/4" x 4"	60	Carton	<del>160.64</del>
---------------	---	--------------	-------------	----	--------	-------------------

\* Contains 20% post-consumer recycled content, 25% total recycled content.



## H ADVANCED BATH TISSUE

Soft and absorbent bath tissue, handsomely embossed. Easy start tail prevents waste. Each roll is elegantly wrapped ensuring sanitary protection. Features rapid breakup, ideal for all plumbing systems and safe for septic systems. For Use With: Tork® T24 Conventional Bath Tissue Dispensers - 55TR, 59TR.

ID No.	Ply	No. of Tissues	W x L	Qty.	Unit	Price
10 TRK-TM6120S *	2	500	4" x 3.75"	96	Carton	<del>145.78</del>
11 TRK-245989 *	2	500	4" x 3.75"	80	Carton	<del>119.62</del>

\* TRK-TM6120S—EcoLogo Certified; EPA Compliant. Contains 20% post-consumer recycled content, 100% total recycled content.

\* TRK-245989—EcoLogo Certified; EPA Compliant; Green Seal Certified. Contains 25% post consumer recycled content, 100% total recycled content.

## I UNIVERSAL BATH TISSUE

Absorbent economical toilet paper that delivers value and performance; attractively embossed to enhance bulk and softness. Features rapid breakup, ideal for all plumbing systems and safe for septic systems. For Use With: Tork® T24 Conventional Bath Tissue Dispensers - 55TR, 59TR.

ID No.	Ply	No. of Tissues	W x L	Qty.	Unit	Price
12 TRK-TM1616S *	2	500	4" x 3.75"	96	Carton	<del>130.69</del>
13 TRK-TS1636S *	1	1000	4" x 3.75"	96	Carton	<del>129.66</del>

\* EcoLogo Certified; EPA Compliant. Contains a minimum of 20% post-consumer recycled content, 100% total recycled content.

# Office Furnishings Paper Towel & Dispensers/Jumbo Roll Tissue



## A ESSENTIAL JRT

The reliable and practical choice. One roll of this high capacity tissue equals nearly 5 standard rolls. This system is ideal for those high traffic areas by helping reduce run-outs and re-fills. Meets EPA Standards for minimum post consumer waste content. ♻️ ♻️ ♻️

ID No. Ply W x L Qty. Unit Price

8.9" Diameter						
1	KCC-07805	★	2	3 1/2" x 1,000 ft	12 Carton	<del>170.02</del>
9" Diameter						
2	KCC-07223	★	1	3 1/2" x 2,000 ft	12 Carton	<del>173.25</del>

★ Contains 40% post-consumer recycled content, 100% total recycled content.

## B ESSENTIAL™ EXTRA SOFT JRT

The brand you know and trust. This tissue combines high-capacity JRT with the premium quality of Kleenex®. White, nonperforated sheets. 9" roll diameter. This product is made from wood that came from a certified managed forest. ♻️ ♻️

ID No. Ply W x L Qty. Unit Price

3	KCC-07304	★	2	3 1/2" x 750 ft	12 Carton	<del>137.89</del>
---	-----------	---	---	-----------------	-----------	-------------------

★ Contains 20% post-consumer recycled content, 25% total recycled content.

## C ESSENTIAL JRT EXTRA LONG

Reliable, practical and long-lasting jumbo roll bath tissue. White. This product is made from wood that came from a certified managed forest. ♻️ ♻️ ♻️

ID No. Ply W x L Qty. Unit Price

12" Diameter						
4	KCC-07827	★	2	3 1/2" x 2,000 ft	6 Carton	<del>169.66</del>

★ Contains 40% post-consumer recycled content, 100% total recycled content.

## D ESSENTIAL CORELESS JRT

Made with 100% recycled fiber. Meets EPA standards for minimum post consumer waste content. ♻️ ♻️ ♻️

ID No. Ply W x L Qty. Unit Price

5	KCC-07006	★	2	3 3/4" x 1,150 ft	12 Carton	<del>140.06</del>
6	KCC-07005	★	1	3 3/4" x 2,300 ft	12 Carton	<del>158.46</del>

★ KCC-07006—Contains 50% post-consumer recycled content, 65% total recycled content.  
KCC-07005—Contains 70% post-consumer recycled content, 100% total recycled content.

## E ESSENTIAL 100% RECYCLED FIBER JRT

Made with 100% recycled fiber. Meets EPA standards for minimum post consumer waste content. ♻️ ♻️ ♻️

ID No. Ply W x L Qty. Unit Price

7	KCC-67805	★	2	3.55" x 1,000 ft	12 Carton	<del>170.02</del>
---	-----------	---	---	------------------	-----------	-------------------

★ Contains 75% post-consumer recycled content, 100% total recycled content.



## F UNIVERSAL JUMBO BATH TISSUE

Delivers value and performance. Universal core is designed to fit virtually all size jumbo tissue dispensers. Designed to maximize performance and convenience while minimizing your overall costs. Extra long-lasting tissue means fewer changes, less maintenance and better control of paper waste. Smaller case cubes, frees up about 40% more storage space vs. conventional rolls. Featuring rapid breakup, ideal for all plumbing systems and safe for septic systems. For Use With: Tork® T22 Jumbo Bath Tissue Dispensers - 56TR, 66TR. ♻️ ♻️ ♻️

ID No. Ply W x L Qty. Unit Price

8	TRK-TJ0912A	★	1	3.48" x 2,000 ft	12 Carton	<del>128.76</del>
9	TRK-TJ1212A	★	1	3.48" x 4,000 ft	6 Carton	<del>123.65</del>
10	TRK-TJ0928	★	2	3.48" x 750 ft	12 Carton	<del>53.82</del>
11	TRK-TJ0922A	★	2	3.48" x 1,000 ft	12 Carton	<del>97.64</del>
12	TRK-TJ1222A	★	2	3.48" x 2,000 ft	6 Carton	<del>71.43</del>

★ EcoLogo Certified; EPA Compliant. Contains 20% post-consumer recycled content, 100% total recycled content.



## G BOARDWALK® GREEN JUMBO BATHROOM TISSUE

Two-ply jumbo tissue roll for janitorial and sanitation use. Large roll is great for heavy traffic applications. For Use With: Standard Jumbo Tissue Dispensers. ♻️ ♻️ ♻️

ID No. Ply W x L Qty. Unit Price

13	BWK-59GREEN	★	2	3.48" x 1,000 ft	12 Carton	<del>69.64</del>
----	-------------	---	---	------------------	-----------	------------------

★ EcoLogo Certified; EPA Compliant; LEED Applicable. Contains a minimum of 20% post consumer recycled content, 100% total recycled content.

## H JRT JUMBO ROLL BATHROOM TISSUE

Embossed bath tissue for long-lasting and economical performance. Ideal for high-traffic restrooms.

ID No. Ply W x L Qty. Unit Price

14	BWK-6100	2	3 1/2" x 1,000 ft	12 Carton	<del>84.92</del>
15	BWK-6102	2	3 1/2" x 2,000 ft	6 Carton	<del>86.13</del>

## I JUMBO ROLL BATHROOM TISSUE

Soft, white toilet tissue is a perfect choice for high-traffic restrooms. Septic safe. Jumbo rolls ensure more feet per roll, resulting in fewer roll changes. Laminated for excellent strength and ply bonding.

ID No. Ply W x L Qty. Unit Price

16	BWK-410320	2	3.2" x 525 ft	12 Carton	<del>89.94</del>
17	BWK-410323	2	3.4" x 1000 ft	12 Carton	<del>77.54</del>

## J JRT JR. BATHROOM TISSUE

Economical roll is produced using recycled fibers. Embossed for added softness and absorbency. ♻️ ♻️

ID No. Ply W x L Qty. Unit Price

18	BWK-6101	★	1	3 1/2" x 2000 ft	12 Carton	<del>121.38</del>
----	----------	---	---	------------------	-----------	-------------------

★ Contains 35% pre-consumer recycled content, 65% post-consumer recycled content, 100% total recycled content.





**A STAINLESS STEEL CORELESS DOUBLE ROLL BATH TISSUE DISPENSER**

Sleek, durable, stainless steel coreless double roll bath tissue dispenser holds two full standard coreless rolls of tissue.

ID No.	Color	W x D x H	Unit	Price
1 KCC-09606	Stainless Steel	7 1/8" x 10 1/4" x 6 3/4"	Each	64.00

**B ESSENTIAL™ CORELESS SRB TISSUE DISPENSER**

Sleek and durable, this Coreless Double Roll Bathroom Tissue Dispenser holds 2 full standard rolls of coreless tissue. These dispensers meet the ADA Standards for Accessible Design, 28CFR Part 36 (1994), local rules may vary.

ID No.	Color	W x D x H	Unit	Price
2 KCC-09604 ★	Smoke	11" x 6" x 7 3/4"	Each	36.00
3 KCC-09605	White	11" x 6" x 7 3/4"	Each	32.00

★ KCC-09604—When Properly Installed, Meets ADA Standards for Accessible Design.

**C ESSENTIAL™ SRB TISSUE DISPENSER**

Offers a high capacity, easy maintenance system that can help lower maintenance costs.

ID No.	Color	W x D x H	Unit	Price
4 KCC-09021	Smoke	6" x 6 3/4" x 13 3/4"	Carton	36.10

**D PRO™ HIGH CAPACITY CORELESS SRB TISSUE DISPENSER**

Double your dispensing capacity. This standard roll bathroom tissue dispenser is more compact than the leading high capacity SRB system.

ID No.	Color	W x D x H	Unit	Price
5 KCC-44518	Black	11 1/4" x 6 3/4" x 12 3/4"	Carton	54.40
6 KCC-44517	White	11 1/4" x 6 3/4" x 12 3/4"	Carton	54.40

**E PRO™ CORELESS JUMBO ROLL TISSUE DISPENSER**

High-capacity bath tissue system perfect for your busy workplace. Keyless, one-handed reloading for easy maintenance; no moving parts. Durable plastic.

ID No.	Color	W x D x H	Unit	Price
7 KCC-39709	Brushed Metallic	14 1/2" x 5.8" x 10.4"	Each	150.00
<b>MOD</b>				
8 KCC-34831	Smoke	14 1/2" x 5 1/2" x 10 1/2"	Each	45.00
9 KCC-34832	White	14 1/2" x 5 1/2" x 10 1/2"	Each	45.00

**F ESSENTIAL™ CORELESS JUMBO ROLL TISSUE DISPENSER**

High-capacity bath tissue system perfect for your busy workplace. Keyless, one-handed reloading for easy maintenance; no moving parts. Durable plastic.

ID No.	Color	W x D x H	Unit	Price
10 KCC-09603	White	14 1/4" x 6" x 9 3/4"	Each	51.20

**G PRO™ CORELESS TWIN JUMBO ROLL TISSUE DISPENSER**

Coreless JRT Jr. Bathroom Tissue Dispenser System is a high-capacity system, ideal for high-traffic areas. System with high-capacity rolls requires less maintenance and fewer refills.

ID No.	Color	W x D x H	Unit	Price
11 KCC-39731 ★	Black	23 1/2" x 6 3/4" x 11 1/4"	Carton	57.60

★ When installed properly, this dispenser meets ADA Standard 28 CFR Part 36 (2010), local rules may vary.



**H CORED JRT JUMBO COMBINATION TISSUE DISPENSER**

Cored JRT Combo Unit Bathroom Tissue Dispenser can be used with two JRT Jr. rolls or one JRT Sr. roll and a stub roll. An easy to use mechanism adjusts to meet the customer's needs.

ID No.	Color	W x D x H	Unit	Price
12 KCC-09551	Smoke/Gray	20 3/4" x 5 3/4" x 13 1/2"	Each	100.65



**I TWIN STANDARD ROLL BATH TISSUE DISPENSER**

Translucent and sleek cover allows for "at-a-glance" inspection for refills, hides scratches and maintains image. Improves hygiene, allowing you to only touch the paper you need. High capacity for reduced costs and fewer service interruptions.

ID No.	Color	W x D x H	Unit	Price
13 TRK-59TR	Smoke/Gray	12.75" x 5.57" x 8.25"	Carton	44.40
14 TRK-55TR	Smoke	7.5" x 7" x 12.75"	Carton	59.20

**J TWIN JUMBO ROLL BATH TISSUE DISPENSER**

High-impact, rigid vinyl plastic construction allows toilet tissue dispenser to provide years of service. Flame-retardant and chemical-resistant dispenser is built strong to increase safety. High-capacity toilet tissue dispenser results in fewer run-outs.

ID No.	Color	W x D x H	Unit	Price
15 TRK-56TR	Smoke/Gray	19.29" x 5.51" x 11.83"	Carton	72.13

**K JUMBO BATH TISSUE DISPENSER**

Sturdy toilet tissue dispenser with a clean, modern appearance that complements all decors. Translucent cover allows for "at a glance" inspection for refills. Smooth cover with no recesses is easy to clean and maintain. Sleek cover hides scratches and maintains image.

ID No.	Color	W x D x H	Unit	Price
16 TRK-67TR	Smoke	12.9" x 5.8" x 14.9"	Carton	63.07
17 TRK-66TR	Smoke	10.63" x 5.75" x 12"	Carton	45.39



**L JUMBO TWIN TOILET TISSUE DISPENSER**

Sturdy toilet tissue dispenser houses universal jumbo rolls. Auto transfer and double coverage eliminates run-outs, providing access to replacement roll after initial roll depletes. Prevents waste and saves labor by ensuring one roll is used up before transferring to the second. Manufacturer's limited one-year warranty.

ID No.	Color	W x D x H	Unit	Price
18 BWK-1529	Black	20 1/4" x 6" x 12 1/4"	Each	80.65

**M SINGLE JUMBO TOILET TISSUE DISPENSER**

Attractive, user friendly toilet tissue dispenser is a great choice for public restrooms. Ensures patrons have paper when they need it. Easy access to paper and multi-directional tearing. Manufacturer's limited one-year warranty.

ID No.	Color	W x D x H	Unit	Price
19 BWK-1519	Black	11" x 6 1/4" x 12 1/4"	Each	47.57

Prices subject to change without notice. Visit our website for the latest pricing and product information.

# Office Furnishings Paper Towel & Dispensers/Folded Paper Towels



**new**



## A REVEAL MULTI-FOLD TOWELS

Offer your restroom guests an upgraded hand drying experience. Visitors take a towel without taking a step, so you can say goodbye to water splashes and sprays on floors and countertops. You'll say hello to a solution that elevates the cleanliness and image of your facility by dispensing superior hand towels. The white towels are embossed with the trusted Kleenex logo and offer a balance of softness and strength to dry hands thoroughly. These towels dispense one at a time, so you only touch the towel you use. Throw away those germs and you'll enjoy peace of mind when it comes to the hygiene of your staff and your guests.

ID No.	Color	Qty.	Unit	Price
1 KCC-46321	White	16	Carton	92.04

## B C-FOLD PAPER TOWELS

Towels create a premium hand-drying experience and fit into standard C-Fold dispensers. This product was made from wood that came from a certified managed forest.

ID No.	Color	Qty.	Unit	Price
<b>C-Fold Paper Towels</b> —10½" × 13½". 150 towels per pack.				
2 KCC-01500	White	2400	Carton	119.84
<b>C-Fold Paper Towels</b> —10½" × 13½". Four inner poly bags of four packs each. 150 towels per pack.				
3 KCC-88115	White	2400	Carton	142.59

\* EcoLogo Certified; Meets EPA standards. Contains 40% post-consumer recycled content, 50% total recycled content.  
 KCC-01500—ABSORBENCY POCKETS™ with quilted embossed pattern.  
 KCC-88115—ABSORBENCY POCKETS™ with quilted embossed pattern— 4 Pack Bundle.

## C MULTIFOLD PAPER TOWELS

Towels are soft, premium and absorbent, so you can enjoy efficient hand drying and less waste. This product was made from wood that came from a certified managed forest.

ID No.	Color	Qty.	Unit	Price
<b>Multi-Fold Towels</b> —9½" × 9½". 150 towels per pack.				
4 KCC-01890	White	2400	Carton	92.42
<b>Multi-Fold Towels, Convenience Pack</b> —9½" × 9½". 150 towels per pack.				
5 KCC-02046	White	8	Carton	45.73
<b>Multi-Fold Towels, 4 Pack Bundle</b> —9½" × 9½". Four inner poly bags of four packs each. 150 towels per pack.				
6 KCC-88130	White	2400	Carton	126.72

\* EcoLogo Certified; Meets EPA standards. Contains 40% post-consumer recycled content, 50% total recycled content. ABSORBENCY POCKETS™ with quilted embossed pattern.

## D PREMIERE FOLDED TOWELS

Made to eliminate dispensing problems—and guaranteed! Designed to dispense one-at-a-time, every time. Can virtually eliminate tear-out and messy towel litter. Now with Zip-Half Pack cases. Meets EPA standards with a minimum of 40% post consumer waste.

ID No.	Color	W × L	No. of Sheets	Qty.	Unit	Price
7 KCC-13253	White	7½" × 12½"	120	3000	Carton	111.30
8 KCC-13254	White	9½" × 12½"	120	3000	Carton	138.37

\* EcoLogo Certified; Meets EPA standards. Contains 40% post-consumer recycled content, 50% total recycled content. ABSORBENCY POCKETS™ with quilted embossed pattern.



## E CONTROL™ SLIMFOLD™ TOWELS

Compact towels with Absorbency Pockets allow you to fit a paper towel dispenser in small spaces.

ID No.	Color	W × L	No. of Sheets	Qty.	Unit	Price
9 KCC-04442	White	7½" × 11½"	90	2160	Carton	59.90

\* EcoLogo Certified; Meets EPA standards. Contains 40% post-consumer recycled content, 50% total recycled content.



## F HAND TOWELS IN A POP-UP\* BOX

Premium hand towels for a luxury-class image. This product was made from wood that came from a certified managed forest.

ID No.	Color	Qty.	Unit	Price
10 KCC-01701CT	White	2160	Carton	135.36

\* Contains 40% post-consumer recycled content, 50% total recycled content.

## G ULTRA SOFT POP-UP\* BOX HAND TOWELS

Premium, soft hand towels for a luxury-class image.

ID No.	Color	W × L	No. of Sheets	Qty.	Unit	Price
11 KCC-11268	White	9" × 10"	70	70	Box	5.54



## H ESSENTIAL™ SINGLE-FOLD PAPER TOWELS

An economical addition to your busy restroom. You can trust that you'll get what you need for efficient hand drying.

ID No.	Color	Qty.	Unit	Price
<b>SINGLE-FOLD TOWELS</b> —9½" × 10½". 250 towels per pack.				
12 KCC-01700	White	4000	Carton	124.16

\* EcoLogo Certified; Meets EPA standards. Contains 40% post-consumer recycled content, 60% total recycled content.

## I ESSENTIAL™ 100% RECYCLED FIBER MULTI-FOLD TOWELS

An economical multifold towel choice. Made with 100% recycled fiber (RF), so you can feel good about choosing them for your business. Plus, they fit into any universal dispenser for trifold paper towels or multifold towels (which helps control over use). Made with a minimum of 40% post-consumer waste.

ID No.	Color	W × L	No. of Sheets	Qty.	Unit	Price
13 KCC-01804	White	9½" × 9½"	250	4000	Carton	111.17

\* EcoLogo Certified; Meets EPA standards. Contains 40% post-consumer recycled content, 60% total recycled content. ABSORBENCY POCKETS™ with quilted embossed pattern.

## J ESSENTIAL™ MULTI-FOLD TOWELS

Made with 100% recycled fiber. Meets EPA standards for minimum post consumer waste content (towels: 40%). Towel codes contain no added fragrances.

ID No.	Color	Qty.	Unit	Price
14 KCC-01807	White	4000	Carton	164.93
15 KCC-01840	White	4000	Carton	160.50

\* EcoLogo Certified; Meets EPA standards. ABSORBENCY POCKETS™ with quilted embossed pattern.  
 KCC-01807—Contains 70% post-consumer recycled content, 100% total recycled content.  
 KCC-01840—Contains 40% post-consumer recycled content, 60% total recycled content.

## K ESSENTIAL™ C-FOLD TOWELS

Designed to reduce waste and provide excellent, economical drying for hands and surfaces. This product was made from wood that came from a certified managed forest.

ID No.	Color	W × L	No. of Sheets	Qty.	Unit	Price
16 KCC-01510	White	10½" × 13½"	200	2400	Carton	97.47
<b>Convenience Pack</b>						
17 KCC-03623	White	10½" × 13½"	200	9	Carton	76.50

\* EcoLogo Certified; Meets EPA Standards. Contains 40% post-consumer recycled content, 60% total recycled content.  
 KCC-01510—ABSORBENCY POCKETS™ with quilted embossed pattern.

## L PRO SCOTTFOLD TOWELS

Make wasted paper towels a thing of the past with these towels. Unique fold is designed for true one-at-a-time dispensing, every time.

ID No.	Color	W × L	No. of Sheets	Qty.	Unit	Price
18 KCC-01960	White	7½" × 12½"	175	25	Carton	90.90
19 KCC-01980	White	9½" × 12½"	175	25	Carton	118.05

\* Contains 40% post-consumer recycled content, 60% total recycled content. ABSORBENCY POCKETS™ with quilted embossed pattern.  
 KCC-01960—EcoLogo Certified; Meets EPA standards.  
 KCC-01980—EcoLogo Certified; EPA Compliant; Green Seal Certified; LEED Applicable.



A

## A PREMIUM SOFT XPRESS® 3-PANEL MULTIFOLD HAND TOWELS

Superior appearance, hand feel, strength and absorbency. Maintain a high-end image with reduced waste and clutter. High-performance towels result in customers using fewer per use and greater cost savings.

ID No.	Color	W × L	Qty.	Unit	Price
1 TRK-100297	White	8.35" × 13.4"	2100	Carton	141.59

## B FOLDED PAPER TOWELS

Soft and absorbent towels offer the perfect combination of quality, performance and value. Multifold design offers quality and value for high volume restrooms. Processed without chlorine.

ID No.	Color	Qty.	Unit	Price
2 TRK-101293 *	White	3024	Carton	95.37

\* **EcoLogo Certified; EPA Compliant. Contains 50% post-consumer recycled content, 100% total recycled content.**

## C PREMIUM MULTIFOLD TOWEL

Ultra soft and absorbent folded towels provide premium quality. Excellent wet strength. Designed to help control usage and reduce waste.

ID No.	Color	Qty.	Unit	Price
3 TRK-MB576 *	White	16	Carton	68.47
4 TRK-MB572 *	White	3008	Carton	164.35

**MULTI-FOLD**—9½ × 9½, 250 per pack.

5 TRK-420570 *	White	12	Carton	72.52
----------------	-------	----	--------	-------

\* **TRK-MB576, TRK-MB572**—EPA Compliant. Contains 40% post-consumer recycled content, 50% total recycled content.  
**TRK-420570**—Green Seal Certified; EcoLogo Certified; EPA Compliant. Contains 40% post-consumer recycled content, 100% total recycled content.

## D ADVANCED MULTIFOLD HAND TOWEL

Soft and absorbent, these multifold hand towels provide the right combination of quality, performance and value. Fast absorbency and "no touch" service helps to control usage while offering sanitary conditions. Ideal for medium traffic washrooms, fits small spaces and provides both comfort and hygiene to your guests.

ID No.	Color	Qty.	Unit	Price
6 TRK-424814 *	White	16	Carton	64.40
7 TRK-420554	White	16	Carton	50.29

\* **TRK-424814**—EcoLogo Certified. Contains 40% post-consumer recycled content, 40% total recycled content.

## E MULTIFOLD HAND TOWEL

These soft and absorbent towels offer the perfect combination of quality, performance and value. Multifold design provides for less towel consumption. Ideal for medium traffic washrooms, fits small spaces.

ID No.	Color	Qty.	Unit	Price
8 TRK-MK520A *	Natural	16	Carton	59.99

### Universal

9 TRK-MB540A *	White	4000	Carton	65.67
----------------	-------	------	--------	-------

**Universal**—9½ × 9½. 250 towels per pack.

10 TRK-420483 *	Natural White	16	Carton	64.51
-----------------	---------------	----	--------	-------

\* **TRK-MK520A, TRK-420483**—EcoLogo Certified; EPA Compliant; Green Seal Certified. Contains 50% post-consumer recycled content, 100% total recycled content.  
**TRK-MB540A**—EcoLogo Certified. Contains 20% post-consumer recycled content, 100% total recycled content.

## F C-FOLD HAND TOWEL

Offer the right combination of performance and value. Fast absorbency helps to control usage, so you save on reduced waste and maintenance time.

ID No.	Color	Qty.	Unit	Price
11 TRK-250630 *	Natural White	16	Carton	51.64

### Advanced

12 TRK-250520 *	White	16	Carton	64.01
-----------------	-------	----	--------	-------

### Universal

13 TRK-CB530 *	White	54	Carton	82.52
----------------	-------	----	--------	-------

\* **TRK-250630**—EcoLogo Certified; Green Seal Certified. Contains 50% post-consumer recycled content, 100% total recycled content.  
**TRK-250520**—EcoLogo Certified. Contains 40% post-consumer recycled content, 75% total recycled content.  
**TRK-CB530**—EcoLogo Certified. Contains 20% post-consumer recycled content, 100% total recycled content.



## boardwalk.

## G BOARDWALK® GREEN FOLDED TOWELS

Absorbent towels. For hand washing and general purposes. Soft, embossed design.

ID No.	Color	Qty.	Unit	Price
--------	-------	------	------	-------

**C-Fold**—10½ × 12½. 150 per pack.

14 BWK-51GREEN *	Natural White	16	Carton	49.75
------------------	---------------	----	--------	-------

**Multi-Fold**—9 × 9½. 250 per pack.

15 BWK-49GREEN *	White	16	Carton	58.84
------------------	-------	----	--------	-------

**Multi-Fold**—9½ × 9½. 250 per pack.

16 BWK-10GREEN *	Natural White	16	Carton	57.61
------------------	---------------	----	--------	-------

\* **BWK-51GREEN**—Green Seal Certified; UL EcoLogo Certified. Contains a minimum of 50% post-consumer recycled content, 100% total recycled content.

**BWK-49GREEN**—EcoLogo Certified; Contains 40% post-consumer recycled content, 75% total recycled content.

**BWK-10GREEN**—Green Seal Certified; LEED Applicable. Contains a minimum of 50% post-consumer recycled content, 100% total recycled content.

## H FOLDED PAPER TOWELS

Hand drying towels for use in commercial restroom dispensers (sold separately).

ID No.	Color	Qty.	Unit	Price
--------	-------	------	------	-------

**C-Fold**—11½ × 10. 200 towels per pack.

17 BWK-6220	White	12	Carton	60.18
-------------	-------	----	--------	-------

**Multi-Fold**—9 × 9½. 250 towels per pack.

18 BWK-6202 *	Natural	16	Carton	66.94
---------------	---------	----	--------	-------

19 BWK-6200	White	16	Carton	58.05
-------------	-------	----	--------	-------

**Single-Fold**—9½ × 9. 250 towels per pack.

20 BWK-6210 *	Natural	16	Carton	66.46
---------------	---------	----	--------	-------

\* **BWK-6202, BWK-6210**—Contains 100% post-consumer recycled content, 100% total recycled content.

## I WINDSHIELD PAPER TOWELS

Soft, absorbent and strong one-ply windshield towel. This multipurpose paper towel is ideal for light wiping tasks.

ID No.	Color	W × L	No. of Sheets	Qty.	Unit	Price
--------	-------	-------	---------------	------	------	-------

21 BWK-6191 *	Blue	9.125" × 10.25"	250	9	Carton	42.60
---------------	------	-----------------	-----	---	--------	-------

\* **Contains 100% total recycled content.**

Prices subject to change without notice.

Visit our website for the latest pricing and product information.

# Office Furnishings Paper Towel & Dispensers/Folded Towel Dispensers



## A SLIMFOLD\* TOWEL DISPENSER

An ultra-slim folded towel dispenser that provides superior hand-drying in places you never thought possible.

ID No.	Color	W x D x H	Unit	Price
1 KCC-34830	White	9 <sup>7</sup> / <sub>8</sub> " x 2 <sup>7</sup> / <sub>8</sub> " x 13 <sup>3</sup> / <sub>4</sub> "	Each	36.00

## B UNIVERSAL TOWEL DISPENSER

Provides attractive and graceful appearance. Curved and contemporary styling. Ideal for Scottfold\* Towels, Multi-folds, and C-folds.

ID No.	Color	W x D x H	Unit	Price
2 KCC-09905	Smoke	13 <sup>3</sup> / <sub>4</sub> " x 5 <sup>1</sup> / <sub>2</sub> " x 18 <sup>1</sup> / <sub>2</sub> "	Each	426.77

\* When Properly Installed, Meets ADA Standards for Accessible Design.



## C MULTIFOLD HAND TOWEL DISPENSER

Compact dispenser unit will accommodate any washroom or restroom design. Includes a see-through front cover to reduce maintenance time, allowing quick and easy service checks.

ID No.	Color	W x D x H	Unit	Price
3 TRK-78T1	Smoke/Gray	12.36" x 5.18" x 13"	Carton	68.45

## D SINGLEFOLD HAND TOWEL DISPENSER

Durable, attractive and economical. This dispenser will blend seamlessly into any restroom environment. Simple installation helps to cut maintenance costs and provide trouble-free service. No moving parts, long lasting with no break downs. The quick view slot allows quick and easy service checks.

ID No.	Color	W x D x H	Unit	Price
4 TRK-70WM1	White	11.75" x 5.75" x 9.25"	Carton	52.00

## E FOLDED TOWEL DISPENSER

Attractive towel dispenser with a clean, modern appearance that complements all decors. Convenient translucent cover allows for easy "at a glance" inspection for refills. Smooth, sleek cover with no recesses is easy to clean and maintain. Smooth hides scratches and maintains image. One-at-a-time dispensing ensures you only touch the towel you take.

ID No.	Color	W x D x H	Unit	Price
5 TRK-73TR	Smoke	11 <sup>3</sup> / <sub>4</sub> " x 6 <sup>1</sup> / <sub>4</sub> " x 18"	Carton	61.00



## F LARGE CAPACITY ULTRAFOLD™ TOWEL DISPENSER

An economical solution for high-capacity dispensing of any brand of C-fold or multifold towel. Ultrafold™ folded towel dispensers offer a clean, low-profile design which make them ideal for tight spaces. The Present® System offers a smooth, one-at-a-time towel presentation of C-fold or multifold towels that enhances efficiency and image.

ID No.	Color	W x D x H	Unit	Price
<b>Classic</b> —Classic, smooth cover.				
6 SJM-T1700TBK	Transparent Black Pearl	11 <sup>3</sup> / <sub>4</sub> " x 6 <sup>1</sup> / <sub>4</sub> " x 18"	Each	62.32
<b>Oceans</b> ®—Oceans® wave design imprinted on cover.				
7 SJM-T1790TBL	Transparent Arctic Blue	11 <sup>3</sup> / <sub>4</sub> " x 6 <sup>1</sup> / <sub>4</sub> " x 18"	Each	63.55
8 SJM-T1790TBK	Transparent Black Pearl	11 <sup>3</sup> / <sub>4</sub> " x 6 <sup>1</sup> / <sub>4</sub> " x 18"	Each	62.32

## G C-FOLD/MULTIFOLD TOWEL DISPENSER

Versatile design allows operators to choose which folded towel to use. This durable dispenser has a large capacity for reduced maintenance costs and a standard key lock to prevent towel theft.

ID No.	Color	W x D x H	Unit	Price
9 SJM-T1900XC	Chrome	11 <sup>3</sup> / <sub>4</sub> " x 4" x 14 <sup>3</sup> / <sub>4</sub> "	Each	136.67

## H SINGLEFOLD TOWEL DISPENSER

Provides dependable, one-at-a-time dispensing of singlefold towels. Durable dispenser includes a standard key lock to prevent towel theft.

ID No.	Color	W x D x H	Unit	Price
10 SJM-T1800XC	Chrome	10 <sup>3</sup> / <sub>4</sub> " x 6" x 7 <sup>1</sup> / <sub>2</sub> "	Each	100.14
11 SJM-T1800WH	White	10 <sup>3</sup> / <sub>4</sub> " x 6" x 7 <sup>1</sup> / <sub>2</sub> "	Each	82.03

## I TRUE FOLD™ C-FOLD/MULTIFOLD TOWEL DISPENSER

Accommodates both C-fold and multifold towels. Easy to use and maintain, the flip door feature eliminates towel waste. The versatile design allows operators to choose which folded towel to use.

ID No.	Color	W x D x H	Unit	Price
12 SJM-T1905WH	White	11 <sup>3</sup> / <sub>4</sub> " x 5" x 14 <sup>1</sup> / <sub>2</sub> "	Each	84.44

## J MINI C-FOLD/MULTIFOLD TOWEL DISPENSER

Compact footprint and versatile design allows operators to choose which folded towel to use. Durable dispenser has a standard key lock to prevent towel theft.

ID No.	Color	W x D x H	Unit	Price
13 SJM-T1950XC	Chrome	11 <sup>1</sup> / <sub>8</sub> " x 3 <sup>3</sup> / <sub>8</sub> " x 7 <sup>7</sup> / <sub>8</sub> "	Each	422.25



## K MINI FOLDED TOWEL DISPENSER

Hygienic, one-at-a-time folded towel dispenser. Accommodates a variety of towel types, including single fold, C-fold and multi-fold. Compact unit fits easily in any washroom. Tough, industrial plastic construction is easy to clean.

ID No.	Color	W x D x H	Unit	Price
14 BWK-FT111SBBW	Smoke Black	5 <sup>3</sup> / <sub>8</sub> " x 12 <sup>3</sup> / <sub>8</sub> " x 13 <sup>3</sup> / <sub>8</sub> "	Carton	39.20



# Paper Towel & Dispensers/Hardwound Towels Office Furnishings



## A CONTROL™ SLIMROLL™ TOWELS

Towel system is a breakthrough in touchless hard roll towel technology. It makes it possible to use a roll towel in small places you never thought possible. This product was made using wood sourced from a certified managed forest.

ID No.	Color	Roll Length	Qty.	Unit	Price
1 KCC-12388 *	White	580 ft	6	Carton	94.75

\* EcoLogo Certified; Meets EPA Standards. Contains 40% post-consumer recycled content, 70% total recycled content.

## B ESSENTIAL™ HARD ROLL TOWEL

Towels are long-lasting to reduce maintenance time, run-outs and complaints.

ID No.	Color	Roll Length	Qty.	Unit	Price
2 KCC-04142 *	Natural	800 ft	12	Carton	158.11
3 KCC-02068 *	White	400 ft	12	Carton	113.34
4 KCC-01040 *	White	800 ft	12	Carton	250.14

\* KCC-04142—Contains 78% post-consumer recycled content, 100% total recycled content. KCC-02068, KCC-01040—Contains 40% post-consumer recycled content, 60% total recycled content. ABSORBENCY POCKETS™ with quilted embossed pattern.

## C ESSENTIAL 100% RECYCLED FIBER HARD ROLL TOWEL

Towels are long-lasting to reduce maintenance time, run-outs and complaints. Made with 100% recycled fiber. Meets EPA standards for minimum post consumer waste content (towels: 40%)

ID No.	Color	Roll Length	Qty.	Unit	Price
5 KCC-01052 *	White	800 ft	12	Carton	251.23

\* Contains 70% post-consumer recycled content, 100% total recycled content.

## D ESSENTIAL HIGH CAPACITY HARD ROLL TOWEL

Reduce maintenance time, run-outs and complaints with this long-lasting roll towel. Highly absorbent, so you'll use less and waste less. Small cases for easy storage and handling. Compatible with most universal hard roll towel dispensers. Meets EPA standards; EcoLogo® certified; Elemental chlorine-free (ECF) bleaching.

ID No.	Color	Roll Length	Qty.	Unit	Price
6 KCC-02001 *	White	950 ft	6	Carton	131.17
7 KCC-02000 *	White	950 ft	6	Carton	150.14
8 KCC-01005 *	White	1,000 ft	6	Carton	150.34
9 KCC-01000 *	White	1,000 ft	12	Carton	281.54

\* KCC-02001—ASTM Certified Compostable; EcoLogo Certified; LEED Applicable. Contains 40% post-consumer recycled content, 70% total recycled content. KCC-02000—Contains 40% post-consumer recycled content, 70% total recycled content. ABSORBENCY POCKETS™ with quilted embossed pattern. KCC-01005—Contains 40% post-consumer recycled content, 60% total recycled content. KCC-01000—Contains 40% post-consumer recycled content, 60% total recycled content. ABSORBENCY POCKETS™ with quilted embossed pattern.

## E ESSENTIAL™ PLUS HARD ROLL TOWELS

Towels are preferred for their superior hand-drying performance. The fast-drying Absorbency Pockets, soft feel and high-capacity rolls are ideal for your busy washroom.

ID No.	Color	Roll Length	Qty.	Unit	Price
<b>1.5" CORE</b>					
10 KCC-01080 *	White	425 ft	12	Carton	192.03
<b>1.75" CORE</b>					
11 KCC-50606 *	White	600 ft	6	Carton	122.37

\* ABSORBENCY POCKETS™ with quilted embossed pattern. KCC-01080—Contains 40% post-consumer recycled content, 60% total recycled content. KCC-50606—Contains 40% post-consumer recycled content, 50% total recycled content.



## F UNIVERSAL HAND TOWEL ROLL

Offers the perfect combination of performance and value. Embossing enhances hand feel and maximum absorbency with fewer towels used per hand dry.

ID No.	Color	Roll Length	Qty.	Unit	Price
12 TRK-RB8002 *	White	800 ft	6	Carton	86.81

\* EcoLogo Certified. Contains 20% post-consumer recycled content, 100% total recycled content.

## G HARDWOUND ROLL TOWEL

Offer the perfect combination of performance and value. Easy to load and maintain for ease of use. Long-lasting rolls minimize maintenance costs while maximizing service.

ID No.	Color	Roll Length	Qty.	Unit	Price
<b>ADVANCED</b>					
13 TRK-RB600 *	White	600 ft	12	Carton	174.39
14 TRK-214404 *	White	1000 ft	6	Carton	103.97

## UNIVERSAL

15 TRK-RK600E *	Natural	600 ft	12	Carton	114.39
16 TRK-RK800E *	Natural	800 ft	6	Carton	100.49
17 TRK-RK1000 *	Natural	1000 ft	6	Carton	90.42
18 TRK-218004 *	Natural White	800 ft	6	Carton	96.51

\* TRK-RB600—EcoLogo Certified. Contains 40% post-consumer recycled content, 100% total recycled content. TRK-214404—EPA Compliant; Green Seal Certified. Contains 50% post-consumer recycled content, 100% total recycled content. TRK-RK600E, TRK-RK800E, TRK-RK1000—EcoLogo Certified; EPA Compliant. Contains 40% post-consumer recycled content, 100% total recycled content. TRK-218004—EcoLogo Certified; EPA Compliant; Green Seal Certified. Contains 50% post-consumer recycled content, 100% total recycled content.



## H BOARDWALK® GREEN UNIVERSAL ROLL TOWELS

Made of recycled materials. Hardwound, non-perforated rolls with embossed design.

ID No.	Color	Roll Length	Qty.	Unit	Price
19 BWK-16GREEN *	Natural	800 ft	6	Carton	63.83
20 BWK-17GREEN *	Natural White	800 ft	6	Carton	84.87

\* Green Seal Certified; LEED Applicable. Contains a minimum of 50% post-consumer recycled content, 100% total recycled content.

## I WHITE PAPER TOWEL ROLLS

These one-ply paper towels are hardwound in rolls without perforations. For hand drying in commercial washrooms. Bleached white.

ID No.	Color	Roll Length	Qty.	Unit	Price
21 BWK-6261B	White	600 ft	12	Carton	134.88
22 BWK-6254B	White	800 ft	6	Carton	69.58

## J PAPER TOWEL ROLLS

These one-ply paper towels are hardwound in rolls without perforations. For hand drying in commercial washrooms.

ID No.	Color	Roll Length	Qty.	Unit	Price
23 BWK-6252	Natural	350 ft	12	Carton	56.57
24 BWK-6260	Natural	600 ft	12	Carton	111.36
25 BWK-6256	Natural	800 ft	6	Carton	46.08
26 BWK-6250	White	350 ft	12	Carton	66.72

Prices subject to change without notice.

Visit our website for the latest pricing and product information.

# Office Furnishings Paper Towel & Dispensers/Hardwound Towel Dispensers

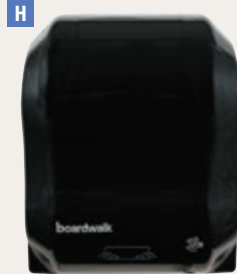

**new**

## A MOD\* SLIMROLL\* TOWEL DISPENSER

Combining touchless technology with the bacteria-reducing benefits of a paper towel; this high-capacity compact dispenser is perfect for small space installations. The dispenser reduces run outs, offers a quick-load design for easy refills, key or keyless entry and provides three times more hand dries per unit with fewer refills than folded towels. Manually operated.

ID No.	Color	W x D x H	Unit	Price
1 KCC-47089 *	Black	12.63" x 10.2" x 16.13"	Carton	<del>91.00</del>
2 KCC-47071 *	White	12.63" x 10.2" x 16.13"	Carton	<del>91.00</del>
3 KCC-47260 ✕	Black	12" x 7" x 12"	Carton	<del>51.00</del>
4 KCC-47261 ✕	White	12" x 7" x 12"	Carton	<del>51.00</del>

\* KCC-47089, KCC-47071—Meets ADA Standard 28 CFR, Part 36, Local Rules May Vary.



## B TOUCHLESS ROLL TOWEL DISPENSER

Offers the hygienic benefits of hands-free dispensing with reliable, hassle-free performance.

ID No.	Color	W x D x H	Unit	Price
5 KCC-09992	Smoke	12 <sup>29</sup> / <sub>100</sub> " x 10 <sup>1</sup> / <sub>8</sub> " x 16 <sup>13</sup> / <sub>100</sub> "	Each	<del>208.00</del>

## C SANITOUCH\* HARD ROLL TOWEL DISPENSER

A reliable, efficient hand-drying system that is perfect for your busy workplace.

ID No.	Color	W x D x H	Unit	Price
6 KCC-09990 *	Smoke	12 <sup>29</sup> / <sub>100</sub> " x 10 <sup>1</sup> / <sub>8</sub> " x 16 <sup>13</sup> / <sub>100</sub> "	Each	<del>186.62</del>
7 KCC-09991 *	White	12 <sup>29</sup> / <sub>100</sub> " x 10 <sup>1</sup> / <sub>8</sub> " x 16 <sup>13</sup> / <sub>100</sub> "	Each	<del>144.00</del>

\* When installed properly this dispenser meets the ADA Standards for Accessible Design, 28 CFR Part 36, local rules may vary.



## D ESSENTIAL™ MANUAL HARD ROLL TOWEL DISPENSER

Designed to provide long-lasting service, reducing disruptions and user complaints. Touchless dispensing reduces the spread of germs and creates a more hygienic environment. Battery-free dispenser provides long-lasting service with less necessary maintenance. Easy to reload in a few simple steps. Manufacturer's limited lifetime warranty.

ID No.	Color	W x D x H	Unit	Price
8 KCC-46253 *	Smoke	13.06" x 11" x 16.94"	Carton	<del>119.00</del>
9 KCC-46254 *	White	13.06" x 11" x 16.94"	Carton	<del>119.00</del>

\* ADA Compliant.



## E HAND TOWEL ROLL DISPENSER PUSH BAR

High-capacity dispenser solution with the ability to hold 1,000 feet of 8" diameter hardwound paper roll towels. The see-through front cover reduces maintenance and allows for quick and easy service checks.

ID No.	Color	W x D x H	Unit	Price
11 TRK-84TR	Smoke/Gray	10.5" x 8.75" x 15.75"	Carton	<del>145.17</del>

## F HAND TOWEL DISPENSER

Attractive dispenser presents a clean, modern appearance which complements all décor. Translucent cover allows for "at a glance" inspection for refills.

ID No.	Color	W x D x H	Unit	Price
12 TRK-86ECO	Translucent Smoke	11.78" x 9.12" x 14.39"	Carton	<del>107.20</del>

## G COMPACT HAND TOWEL ROLL DISPENSER

Save space with this super compact dispenser. High-capacity dispenser holds up to 1,000 feet of 8-inch diameter hardwound roll towels. See-through front helps reduce maintenance and allows for quick and easy service checks. Easy to load. Ergonomic handle is designed for ease of use. Made with durable, impact-resistant plastic. Elegant appearance complements any décor.

ID No.	Color	W x D x H	Unit	Price
13 TRK-83TR	Smoke	12.49" x 8.6" x 12.82"	Carton	<del>114.05</del>



## H HANDS FREE MECHANICAL TOWEL DISPENSER

Convenient hands-free mechanical towel dispenser provides easy access to towels while minimizing cross-contamination. Does not require batteries. Automatic mechanical cutting dispenses 11" portions of paper, plenty for your patrons to dry their hands with. Replaceable drive module. Manufacturer's limited one-year warranty.

ID No.	Color	W x D x H	Unit	Price
14 BWK-1501	Black	13 <sup>3</sup> / <sub>4</sub> " x 10 <sup>1</sup> / <sub>4</sub> " x 16 <sup>1</sup> / <sub>4</sub> "	Each	<del>138.53</del>

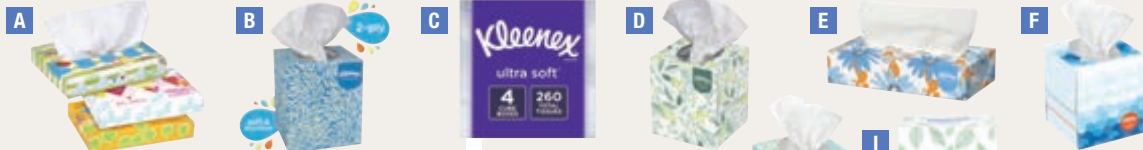

## A FACIAL TISSUE JUNIOR PACK

Delivers premium quality and is preferred for its superior softness, absorbency and strength. The junior sized boxes are ideal for sensitive environments where a fresh box is needed.

ID No.	Ply	No. of Tissues	Qty.	Unit	Price
<b>FLAT BOX</b>					
1 KCC-21195	2	40 per box	80	Carton	115.52

## B BOUTIQUE BOX FACIAL TISSUE

The Kleenex® Brand's strongest tissue, so it's easy to see why it's preferred for its softness, absorbency and strength.

ID No.	Ply	No. of Tissues	Qty.	Unit	Price
2 KCC-21270BX	2	95 per box	1	Box	4.75
3 KCC-21271	2	95 per box	6	Pack	31.05
4 KCC-21271CT	2	95 per box	6	Carton	186.28

**Value Pack**—Stock up and save!

5 KCC-21270CT	2	95 per box	36	Carton	171.18
---------------	---	------------	----	--------	--------

## C ULTRA SOFT FACIAL TISSUE

Ultra-soft absorbent facial tissue is kind to runny noses. Durable three-ply tissue provides softness and strength, preventing break-through. Added sneeze shield helps keep hands clean.

ID No.	Ply	No. of Tissues	Qty.	Unit	Price
6 KCC-50173	3	65 per box	4	Pack	12.18

## D NATURALS PROFESSIONAL FACIAL TISSUE

Made with Softblend® Fiber, the perfect blend of soft, virgin fiber and recycled fiber. This product is made from wood that came from a certified managed forest.

ID No.	Ply	No. of Tissues	Qty.	Unit	Price
<b>BOUTIQUE* POP-UP* Box</b>					
7 KCC-21272 *	2	95 per box	36	Carton	163.52
<b>Flat Box</b>					
8 KCC-21601 *	2	125 per box	48	Carton	174.72

\* Contains 20% post-consumer recycled content, 20% total recycled content.

## E FACIAL TISSUE

Delivers premium quality and is preferred for its superior softness, absorbency and strength.

ID No.	Ply	No. of Tissues	Qty.	Unit	Price
9 KCC-03076	2	125 per box	12	Carton	58.88
10 KCC-21005	2	100 per box	30	Carton	138.76
11 KCC-21400	2	100 per box	36	Carton	124.54

**Value Pack**—Stock up and save!

12 KCC-21606CT	2	125 per box	48	Carton	183.36
----------------	---	-------------	----	--------	--------

## F ANTI-VIRAL FACIAL TISSUE

A 3-ply tissue with a moisture-activated middle layer that is scientifically proven to kill 99.9% of cold and flu viruses.

ID No.	Ply	No. of Tissues	Qty.	Unit	Price
13 KCC-49978CT *	3	60 per box	27	Carton	143.43

\* The reduction in probability of infection is based upon mathematical modeling referenced in the Workplace Wellness Intervention Study, University of Arizona, July 9, 2011.

## G BOUTIQUE\* ANTI-VIRAL FACIAL TISSUE

A three-ply tissue with a moisture-activated middle layer that is scientifically proven to kill 99.9% of cold and flu viruses.

ID No.	Ply	No. of Tissues	Qty.	Unit	Price
<b>3-Box Shrink Wrapped</b>					
14 KCC-21286CT	3	68 per box	4	Carton	75.26

## H LOTION FACIAL TISSUE

Soft lotion tissue. Fragrance-free tissues infused with pure aloe and vitamin E and soothe tender skin.

ID No.	Ply	No. of Tissues	Qty.	Unit	Price
15 KCC-49974	2	65 per box	1755	Carton	143.42
16 KCC-50174	2	65 per box	4	Pack	18.25



## I FACIAL TISSUE

Superb combination of value, softness and two-ply strength from the leading brand of facial tissue. This product is made from wood that came from a certified managed forest.

ID No.	Ply	No. of Tissues	Qty.	Unit	Price
17 KCC-21340 *	2	100 per box	30	Carton	85.73
18 KCC-21390 *	2	125 per box	60	Carton	167.84

\* Contains 40% post-consumer recycled content, 45% total recycled content.



## J UNIVERSAL FACIAL TISSUE

Soft and absorbent facial tissue which offers the right combination of performance and value.

ID No.	Ply	No. of Tissues	Qty.	Unit	Price
19 TRK-TF6710A *	2	100	30	Carton	88.93

\* EcoLogo Certified. Contains 20% post-consumer recycled content, 100% total recycled content.

## K ADVANCED FACIAL TISSUE

Extra soft and absorbent 2-ply facial tissue which offers the right combination of performance and value.

ID No.	Ply	No. of Tissues	Qty.	Unit	Price
<b>Cube Box</b>					
20 TRK-TF6830 *	2	94	36	Carton	83.28
<b>Flat Box</b>					
21 TRK-TF6810 *	2	100	30	Carton	89.76

\* TRK-TF6830—EPA Compliant. Contains 20% post-consumer recycled content, 20% total recycled content.  
TRK-TF6810—EcoLogo Certified. Contains 20% post-consumer recycled content, 100% total recycled content.

## L PREMIUM FACIAL TISSUE

An ultra soft premium facial tissue delivering maximum softness, thickness and absorbency. Different color indicator sheet shows when the tissue box is nearly empty and reduces outages.

ID No.	Ply	No. of Tissues	Qty.	Unit	Price
22 TRK-TF6910A *	2	94	36	Carton	107.15
23 TRK-TF6920A *	2	100	30	Carton	87.86

\* Contains a minimum of 35% post-consumer recycled content, 100% total recycled content.



## M FACIAL TISSUE

Facial tissue in a convenient flat, pop-up box. White.

ID No.	Ply	No. of Tissues	Qty.	Unit	Price
24 BWK-6500	2	100 per box	30	Carton	46.86

Prices subject to change without notice.

Visit our website for the latest pricing and product information.

# Office Furnishings Paper Towel/Kitchen Roll



## A CHOOSE-A-SHEET MEGA ROLL PAPER TOWELS

Provides more towels at a lower cost per sheet. Superior absorbency ensures quick and easy spill cleanup. Choose-a-size perforations allow you to grab a towel that fits your task. This product was made using wood sourced from a certified managed forest.

ID No.	Color	No. of Sheets	Qty.	Unit	Price
1 KCC-47031 *	White	2448	24	Carton	67.49
2 KCC-36371	White	102	30	Carton	83.46

\* KCC-47031—ASTM Certified Compostable.

## B KITCHEN ROLL TOWELS

Towels with absorbency pockets are soft and absorbent enough to handle tough spills and clean up.

ID No.	Color	No. of Sheets	Qty.	Unit	Price
3 KCC-41482 *	White	128	20	Carton	76.99

\* Contains 40% post-consumer recycled content, 80% total recycled content.



## C PREMIERE\* KITCHEN ROLL TOWELS

Premium, cloth-like paper towel that's strong, absorbent and soft on your hands.

ID No.	Color	No. of Sheets	Qty.	Unit	Price
4 KCC-13964	White	70	24	Carton	158.11



## D HANDI-SIZE™ PERFORATED ROLL TOWEL

High-bulk, 2-ply construction that maximizes absorbency for superior spill holding power using fewer towels. Handi-Size sheet allows you to choose less paper and reduce waste. Super strong soft towels hold together even on tough jobs. Ideal for cleaning and wiping all surfaces.

ID No.	Color	No. of Sheets	Qty.	Unit	Price
5 TRK-HB9201 *	White	120	30	Carton	121.29

\* EcoLogo Certified; NSF P1; EPA Certified. Contains 40% post-consumer recycled content, 100% total recycled content.

## E PERFORATED TOWEL ROLL

Provide maximum absorbency for excellent spill holding power. These strong and soft towels hold together even on tough jobs. Ideal for cleaning and wiping surfaces.

ID No.	Color	No. of Sheets	Qty.	Unit	Price
6 TRK-421970 *	White	70	30	Carton	51.36
7 TRK-HB1990A *	White	84	30	Carton	76.23
8 TRK-421900 *	White	100	30	Carton	68.69
<b>Jumbo Roll</b> —High sheet count.					
9 TRK-HK1975A *	Natural	210	12	Carton	84.28
10 TRK-HB1995A *	White	210	12	Carton	75.35

\* TRK-421970—Contains 40% post-consumer recycled content, 100% total recycled content.  
TRK-421900—Green Seal Certified; EPA Compliant. Contains 50% post-consumer recycled content, 100% total recycled content.

TRK-HK1975A—Green Seal Certified; EcoLogo Certified; NSF P1; EPA Compliant; Health Canada Certified. Contains 85% post-consumer recycled content, 100% total recycled content.

TRK-HB1990A, TRK-HB1995A—EcoLogo Certified; NSF P1; EPA Compliant; Health Canada Certified. Contains 20% post-consumer recycled content, 100% total recycled content.



## F SELECT-A-SIZE PAPER TOWELS

Strong, super absorbent, two-ply sheets handle spills fast. Select-a-size, lets you choose the amount you need.

ID No.	Color	No. of Sheets	Qty.	Unit	Price
11 PGC-90963	White	83	8	Carton	35.86
12 PGC-47792	White	83	24	Carton	110.40

## G ESSENTIALS SELECT-A-SIZE PAPER TOWELS

These affordably priced paper towels are strong enough to handle life's everyday spills and messes. These sheets also allow you to control just how much you use depending on the size of the mess.

ID No.	Color	No. of Sheets	Qty.	Unit	Price
13 PGC-74682	White	83	12	Carton	27.37

## H ESSENTIALS PAPER TOWELS

These affordably priced paper towels are strong enough to handle life's everyday spills and messes.

ID No.	Color	No. of Sheets	Qty.	Unit	Price
14 PGC-74657 *	White	40	30	Carton	68.70
15 PGC-75719	White	50	12	Carton	27.70

\* PGC-74657—Rolls are individually wrapped.

## I PAPER TOWELS

These durable everyday towels offer superior strength and absorbency. Contain spills and messes quickly with these convenient paper towels. Two-ply sheets tackle the messiest of messes.

ID No.	Color	No. of Sheets	Qty.	Unit	Price
16 PGC-74796	White	54	12	Carton	60.44



## J OFFICE PACKS PERFORATED TOWELS

Just the right quantity for your office. Packaged for easy transporting, dispensing and storage.

ID No.	Color	No. of Sheets	Qty.	Unit	Price
17 BWK-6279CT *	White	140	4	Carton	57.78
18 BWK-6271 *	White	210	12	Carton	44.84

\* Contains 100% post-consumer recycled content, 100% total recycled content.

## K HOUSEHOLD PERFORATED PAPER TOWEL ROLLS

Perfect for household clean up. Embossed paper towel. Two-ply absorbency for general cleaning.

ID No.	Color	No. of Sheets	Qty.	Unit	Price
19 BWK-6277 *	White	100 per roll	30	Carton	57.13
20 BWK-6278B *	White	70	30	Carton	78.83
21 BWK-6276B *	White	80	30	Carton	78.36
22 BWK-6272 *	White	85	30	Carton	49.42
23 BWK-6273 *	White	250	12	Carton	67.52

\* BWK-6277—Contains 40% post-consumer recycled content, 100% total recycled content.

BWK-6278B, BWK-6276B—Contains 35% post-consumer recycled content, 100% total recycled content.

BWK-6272—EcoLogo Certified LEED Applicable. Contains a minimum of 40% post-consumer recycled content, 100% total recycled content.

BWK-6273—Recycled content varies between 30% and 60% post-consumer recycled content, 100% total recycled content.



# Paper Towel/Cloth & Wipers Office Furnishings



**WYPALL**  
BRAND

NSF

## A X60 CLOTHS

A versatile reusable cloth to replace assorted rags. Cloths bring the absorbing power of Hydroknit material technology to a lighter-weight wiper, combining versatile performance and economy for light-duty tasks.

ID No.	Color	W × L	No. of Sheets	Qty.	Unit	Price
1 KCC-54015	White	12½" × 16.8"	252	252	Carton	<del>52.73</del>
<b>Jumbo Roll</b>						
2 KCC-34955	White	12½" × 13.40"	1100	1	Carton	<del>173.03</del>
<b>Small Roll</b>						
3 KCC-35411	Blue	9¾" × 13¾"	130	12	Carton	<del>207.04</del>
<b>Value Pack</b> —Stock up and save!						
4 KCC-34790CT	White	9¾" × 16¾"	126	1260	Carton	<del>199.14</del>
★ KCC-34790CT—Pop-Up® Box.						

## B X50 CLOTHS

Durable and absorbent value cleaning cloth. WypAll brand's most economical extended use cloth. Combines versatile performance with economical design for light-duty tasks.

ID No.	W × L	No. of Sheets	Qty.	Unit	Price
5 KCC-35015	13¾" × 9¾"	1100	1	Roll	<del>104.99</del>

## C L40 TOWELS

Soft like a tissue, yet, absorbs like a sponge; then, toss like a towel. The towels feature unique base sheet technology which creates an absorbent, sponge-like inner layer, with a soft, touchable outer layer.

ID No.	Color	W × L	No. of Sheets	Qty.	Unit	Price
<b>Pop-Up* Box</b>						
6 KCC-05790	White	16¾" × 9¾"	100	900	Carton	<del>200.00</del>
<b>Quarterfold</b> —Ideal for benchtop use. Poly-packed.						
7 KCC-05701	White	12½" × 12"	56	1008	Carton	<del>197.00</del>

## D MICROFIBER CLOTHS

Cloths are reusable (up to 300 washes) and are a terrific green cleaning tool that can be used without harsh chemicals. They're a must-have tool for serious cleaners.

ID No.	Color	No. of Sheets	Qty.	Unit	Price
<b>Bathroom Fixtures</b>					
8 KCC-83620CT	Blue	6	24	Carton	<del>115.14</del>
<b>General Purpose</b>					
9 KCC-83980	Red	6	24	Carton	<del>115.14</del>
10 KCC-83610CT	Yellow	6	24	Carton	<del>115.14</del>
<b>Glass &amp; Mirrors</b>					
11 KCC-83630CT	Green	6	24	Carton	<del>115.14</del>

**KIMTECH**

## E KIMWIPES DELICATE TASK WIPERS

Wipers are designed to handle a variety of delicate tasks, including wiping up liquid and dust.

ID No.	Color	W × L	No. of Sheets	Qty.	Unit	Price
12 KCC-34256BX	White	14¾" × 16¾"	140	140	Box	<del>24.07</del>
<b>Pop-Up* Box</b>						
13 KCC-34155	White	4¾" × 8¾"	280	280	Box	<del>4.81</del>
14 KCC-34120	White	4¾" × 8¾"	280	30	Carton	<del>187.71</del>
<b>Value Pack</b> —Stock up and save!						
15 KCC-34256CT	White	14¾" × 16¾"	140	2100	Carton	<del>361.05</del>

**TORK**

## F CLEANING CLOTH

A soft and flexible multipurpose cleaning cloth that is suitable for janitorial and industrial use. Strong texture for excellent oil and water absorption. Suitable with most solvents and detergents. Reusable, strong, durable wiper. excelCLEAN™ technology — for a fast professional cleaning result.

ID No.	W × L	Scent	Qty.	Unit	Price
16 TRK-510176	8.46" × 16.13"	Unscented	1000	Carton	<del>185.07</del>
★ NSF P1 Certified.					

## G HEAVY-DUTY PAPER WIPER

This tough, multipurpose paper wiper absorbs both oil and water efficiently, features high durability and remains strong even when wet. Soft, cloth-like feel makes it a good choice for wiping solid surfaces or hands and faces. ♻️

ID No.	Color	W × L	No. of Sheets	Qty.	Unit	Price
17 TRK-450175	White	9.25" × 16.25"	90	900	Carton	<del>229.32</del>
★ NSF P1, Health Canada Certified. Contains 20% post-consumer recycled content, 60% total recycled content.						

## H INDUSTRIAL CLEANING CLOTHS

These soft and pliable cloths are an excellent choice to remove oil or grease and clean tight spaces. Uses excelCLEAN™ wiper technology to ensure professional cleaning results.

ID No.	Color	W × L	No. of Sheets	Qty.	Unit	Price
<b>Handy Box</b>						
18 TRK-520371	Gray	14" × 16.9"	280	1	Carton	<del>138.57</del>
★ Health Canada Certified.						

## I HEAVY-DUTY CLEANING CLOTH

A strong and absorbent multipurpose cloth, this reusable wiper is a solid choice for janitorial and industrial cleaning applications. Compatible with many chemical solvents. Picks up and releases solvents more efficiently than textile products, which aid in reducing consumption. Heavy-duty non-woven cloth is designed to protect your hands from heat and metal scraps. Reusable, strong, durable wiper, excellent rental towel and rag replacement.

ID No.	Color	W × L	No. of Sheets	Qty.	Unit	Price
19 TRK-5301755	White	8.46" × 16.13"	80	5	Carton	<del>98.93</del>
★ HACCP; Health Canada Certified.						

## J LOW-LINT CLEANING CLOTH

This soft yet durable cleaning cloth is perfect for surface preparation and cleaning. Designed for use with industrial solvents. Perfect for working with sensitive applications like surface preparation before painting due to low-lint properties. Antistatic properties reduce the likelihood of static electrical discharge.

ID No.	Color	W × L	No. of Sheets	Qty.	Unit	Price
20 TRK-192475	Turquoise	9" × 16.5"	100	800	Carton	<del>191.90</del>
★ Health Canada Certified.						

## K MULTIPURPOSE PAPER WIPER

Handy for a wide range of tasks to limit the number of different cloths needed. Efficient absorbency—ideal for picking up liquid and hand wiping. Reusable, strong, durable wipers, they are an excellent replacement for rental towels and rags. ♻️

ID No.	Color	W × L	No. of Sheets	Qty.	Unit	Price
21 TRK-192127	White	9.25" × 16.25"	100	8	Carton	<del>111.20</del>
★ Contains 20% total recycled content.						

Prices subject to change without notice.

Visit our website for the latest pricing and product information.

323

# Office Furnishings Paper Towel/Wipers



## boardwalk

### A DRC WIPERS

Durable, DRC wipers provide a convenient clean and a cloth-like feel. Highly absorbent wipers. Low-linting wipers are also great for staining.

ID No.	Color	W x L	No. of Sheets	Qty.	Unit	Price
<b>Nine Dispensers of 100</b>						
1	BWK-V030IDW2	White	9.38" x 16.5"	900	900	Carton <del>102.04</del>
<b>12 Bags of 90</b>						
2	BWK-V030QPW	White	12" x 13"	1080	1080	Carton <del>103.95</del>
<b>18 Bags of 56</b>						
3	BWK-V040QPW	White	12" x 13"	1008	1008	Carton <del>126.24</del>

### B SCRIM WIPERS

Economy series wipers are ideal for glass and mirror cleaning. Nylon reinforced for added wet strength. Superior dry wiping capabilities. Low-linting paper wiper can be used for general cleaning, wiping up spills and as a hand wipe.

ID No.	Color	W x L	No. of Sheets	Qty.	Unit	Price
<b>Six Pack Dispensers of 150</b>						
4	BWK-E025IDW *	White	9 3/4" x 16 3/4"	900	900	Carton <del>122.84</del>

\* Contains 40% post-consumer recycled content, 100% total recycled content.

### C DUST CLOTHS

Convenient cloths are treated with mineral oil so spray polish is not needed. Dusters are designed to pucker to grab and trap more particles. Low-linting cloths. Ideal for offices, maintenance facilities and retail stores.

ID No.	Color	W x L	No. of Sheets	Qty.	Unit	Price
<b>Ten Bags of 50</b>						
5	BWK-DSMFPY	Yellow	18" x 24"	500	500	Carton <del>171.91</del>

### D HYDROSPUN WIPERS

Choose the strength and absorbency of durable hydrospun wipers for your everyday tasks. Sturdy, with a cloth-like feel. Solvent-resistant for difficult work.

ID No.	Color	W x L	No. of Sheets	Qty.	Unit	Price
6	BWK-P050JPW	White	10" x 13"	1100	1	Roll <del>131.90</del>
7	BWK-P080JPR	Red	12" x 13"	475	1	Roll <del>152.30</del>
<b>Ten Pack Dispensers of 100</b>						
8	BWK-P070IDB	Blue	9" x 16 3/4"	1000	1000	Carton <del>192.92</del>

### E ADVANCED PERFORMANCE WIPERS

Choose durable wipers for their pleasant, cloth-like feel. Highly absorbent wipers. Resistant to many solvents which make them ideal for cleaning up grease and oil.

ID No.	Color	W x L	No. of Sheets	Qty.	Unit	Price
<b>Ten Pack Dispensers of 100</b>						
9	BWK-A105IDW2	White	9" x 16 3/4"	1000	1000	Carton <del>177.89</del>



## CHIX

### F WET WIPES

General-purpose towels are designed for use with water-based liquids. Nonwoven, low-lint material allows you to use towels on most surfaces. Rinse-and-reuse design.

ID No.	Color	W x L	No. of Sheets	Qty.	Unit	Price
<b>Diamond-Pattern Design</b>						
10	CHI-8507	White/Pink	11 1/2" x 24"	200	200	Carton <del>69.03</del>

### G MULTIPURPOSE TOWEL

Absorbent. Variety of uses.

ID No.	Color	No. of Sheets	Qty.	Unit	Price
11	CHI-8483	White	300	300	Carton <del>193.46</del>

### H STRETCH 'N DUST® CLOTHS

Ideal for general housekeeping and periodic dusting. Stretch before use to activate dust-catching pockets.

ID No.	Color	W x L	No. of Sheets	Qty.	Unit	Price
12	CHI-0413	12 3/4" x 17"	40	400	Carton	<del>205.15</del>
13	CHI-0416	23 3/4" x 24"	20	5	Carton	<del>108.94</del>

### I SOFT CLOTHS

Nonabrasive towels ensure effective, soft and gentle cleaning. Thick fibers deliver excellent absorbency. Highly durable.

ID No.	Color	No. of Sheets	Qty.	Unit	Price	
14	CHI-8007	White	40	1200	Carton	<del>494.62</del>

### J MASSLINN® DUST CLOTHS

Features dust-catching fibers. Mineral-oil treated for increased dust pickup and enhanced finish with no lint or residue. Microban® antimicrobial protection inhibits bacteria growth. Perfect for heavy-duty dusting of floors and large surfaces with high traffic.

ID No.	Color	W x L	No. of Sheets	Qty.	Unit	Price
15	CHI-0213	16" x 24"	50	400	Carton	<del>409.66</del>
16	CHI-8673	24" x 24"	30	150	Carton	<del>116.39</del>
17	CHI-0911	24" x 24"	50	100	Carton	<del>145.43</del>



**MEDIUM-DUTY**



## ADVANTUS

**F STEEL FILE AND STORAGE BINS** Open design holds hanging file folders (sold separately). Sturdy bin is also great for storing office supplies.

ID No.	Color	Size	W × D × H	Unit	Price
9 AVT-63008	Black	Letter	12.5" × 11.25" × 7.38"	Each	54.95
10 AVT-63009	Black	Legal	15.5" × 11.25" × 7.25"	Each	57.60



## SNAP-N-STORE<sup>®</sup> CREATIVE STORAGE

**G FILE BOX** Filing is a snap with this easy-to-assemble unit. Heavy-duty metal snaps hold box together and provide strength. Accommodates hanging file folders. Includes sturdy chrome-steel handles and chrome label holder. Can be disassembled and stored flat. A perfect choice for any office.

ID No.	Color	Size	W × D × H	Material	Qty.	Unit	Price
11 IDE-SNS01533	★ Black	Letter	11.75" × 9.75" × 9.5"	Laminated Fiberboard	1	Each	15.49
12 IDE-SNS01536	★ Black	Letter/ Legal	16.25" × 9.75" × 13.25"	Laminated Fiberboard	1	Each	21.49

★ Contains 50% total recycled content.

## Pendaflex<sup>®</sup>

**A DESKTOP FILE WITH HANGING FOLDERS** Fits on desktop or in file drawer. Holds letter size files up to 6" capacity. Hand holes for carrying. Includes five color Pendaflex<sup>®</sup> hanging folders with tabs and blank inserts. Durable plastic construction.

ID No.	Color	Size	W × D × H	Unit	Price
1 PFX-23013	Black	Letter	12¼" × 6" × 9½"	Each	34.00
2 PFX-23011	Blue	Letter	12¼" × 6" × 9½"	Each	34.00
3 PFX-23054	Granite	Letter	12¼" × 6" × 9½"	Each	34.00

## universal.

**B RECYCLED EXTRA CAPACITY DESKTOP FILE HOLDER** Stylish, simple and smart. Keep it coordinated with sturdy, recycled-plastic desk accessories. Conveniently store, view and retrieve files. Includes step-up inserts for tiered filing. Sturdy plastic.

ID No.	Color	Size	W × D × H	Unit	Price
4 UNV-08123	★ Black	Letter	13¼" × 8½" × 9¾"	Each	23.26

★ Contains a minimum of 30% post-consumer recycled content, 100% total recycled content.

**C COLLAPSIBLE CRATE** Open it when you need it, fold it when you don't. Keep this crate folded and handy in the office for files, in the car for supplies and groceries, or anywhere you would need a quick and useful storage box. Holds letter or legal hanging file folders. Folds to only 3" thick. Made from impact-resistant plastic. Stacks securely up to six high. Snap-on lid is included. Manufacturer's limited one-year warranty.

ID No.	Size	Stacking Strength	Dimensions W × D × H	Color	Qty.	Unit	Price
5 UNV-40010	★ Letter/ Legal	200 lb	17.25" × 14.25" × 10.25"	Black/ Gray	2	Pack	52.25

★ Contains 50% post-consumer recycled content, 50% total recycled content.

## SAFCO

**D ONYX<sup>™</sup> MESH DESKTOP TUB FILE** Versatile organizer features integrated handles for easy carrying. 2 × 3½ standard business card size label holder allows for clear identification. Simply collapse tub for storage.

ID No.	Color	Size	W × D × H	Unit	Price
6 SAF-2162BL	★ Black	Letter	12.5" × 13.75" × 9.5"	Each	45.00

★ GREENGUARD Certified.

**E ONYX<sup>™</sup> DESKTOP BOX FILE** Portable file box with integrated handles features an open top for letter-size hanging files. Collapsible for easy storage when not in use. Durable steel mesh design with black powder-coat finish.

ID No.	Color	Size	W × D × H	Unit	Price
7 SAF-2169BL	★ Black	Letter	12.5" × 7" × 10"	Each	31.00
8 SAF-2170BL	★ Black	Letter	12.5" × 11" × 10"	Each	39.00

★ GREENGUARD Certified.

## VAULT<sup>®</sup> LOCK IT UP!<sup>™</sup>

**H LOCKING FILE CHEST** You'll have worry-free protection when you store and transport your files, valuables and other essentials in these sturdy cases. Combination locks provide convenient security. Chrome steel corners and aluminum body trim provide extra strength. Built-in rails accommodate hanging files. Label holder makes for easy identification of contents. Very Portable. Rubber feet prevent surface scuffing.

ID No.	Color	Size	W × D × H	Unit	Price
13 IDE-VZ01165	★ Black	Letter	13.5" × 10.5" × 13.25"	Each	95.29
14 IDE-VZ01008	★ Black	Letter/ Legal	17.5" × 14" × 12.5"	Each	106.99

### Slim Profile

15 IDE-VZ01187	★ Black	Letter	13.75" × 7.25" × 12.25"	Each	71.79
----------------	---------	--------	-------------------------	------	-------

★ HIPAA Compliant.

**I LOCKING MOBILE FILE CHEST** Telescopic handle and sturdy wheels give you easy mobility while two combination locks provide added security. Built-in rails accommodate two hanging file sizes. Panels are made of diamond-embossed PVC. Features chrome label holder plate, chrome corners and aluminum trim. Telescopic handle extends to 32". Also includes side handles. Front stoppers provide level placement.

ID No.	Color	Size	W × D × H	Unit	Price
16 IDE-VZ01270	★ Black/ Chrome	Letter/ Legal	17.5" × 15.5" × 14.5"	Each	144.79
17 IDE-VZ00307	★ Black/ Black	Letter/ Legal	17.5" × 15.5" × 14.5"	Each	162.79

★ HIPAA Compliant.

## ADVANTUS

**J PLASTIC WEAVE BINS** Attractive black baskets with woven design will get your workspace organized. Great for storing all sorts of items including CDs, DVDs, office supplies and more. Sturdy plastic construction. Manufacturer's 90-day warranty.

ID No.	W × D × H	Size	Qty.	Unit	Price
18 AVT-40326	9.88" × 7.38" × 3.88"	Small	3	Pack	28.36
19 AVT-40327	13.88" × 10.5" × 4.63"	Medium	2	Pack	23.10
20 AVT-40328	13.88" × 10.75" × 8.75"	Large	2	Pack	31.51
21 AVT-40329	Varies	Assorted	3	Pack	36.75

Prices subject to change without notice.

Visit our website for the latest pricing and product information.

# Office Furnishings Portable Files



universal.

## A FILING/STORAGE TOTE

This tough crate can be stored flat (2¾" high) until it is needed, and then can be snapped in place in seconds. You can stack it, even with heavy loads. Holds up to 1½ cu. ft. Includes rods for hanging folders. Manufacturer's limited one-year warranty.

ID No.	Color	Size	W × D × H	Material	Unit	Price
1 UNV-40015	Black	Letter	20.13" × 14.63" × 10.75"	Plastic	Each	41.75
2 UNV-40013	Blue	Letter	20.13" × 14.63" × 10.75"	Plastic	Each	41.75

universal.

## F COLLAPSIBLE MOBILE STORAGE CRATE

Ideal for transporting bulky items with ease in just one trip. High capacity (1.7 cu. ft.) Rolling crate with built-in telescoping handle. Collapses flat to 3-½" for easy storage; opens in seconds. Includes support rails for additional durability and carrying grips on all sides for lifting. Lightweight, extremely durable plastic frame. Two non-marring wheels. Supports up to 60 lbs.

ID No.	W × D × H	Material	Color	Unit	Price
10 UNV-14110	18¼" × 15" × 18¼" to 39¾"	Plastic	Black	Each	69.59

**Pendaflex®**

## B PORTABLE FILE BOXES

This lightweight plastic hanging file box is easy to transport. Includes three Pendaflex® letter-size hanging folders with tabs and blank inserts. Recessed handle folds down for storage.

ID No.	Color	Size	W × D × H	Unit	Price
3 PFX-41742	Black	Letter	11" × 14" × 11½"	Each	33.11
4 PFX-41737	Granite	Letter	11" × 14" × 6½"	Each	24.27
5 PFX-41747	Granite	Letter	11" × 14" × 11½"	Each	33.11

**STOREX**

## C PORTABLE LETTER/LEGAL FILEBOX WITH ORGANIZER LID

Organizer compartment in lid for supplies. Handle and latch for easy, secure transport. Latch accepts padlock (not included). Holds letter or legal files.

ID No.	Color	Size	W × D × H	Unit	Price
6 STX-61510U01C	Black	Letter/ Legal	17.125" × 9.625" × 11"	Each	41.99
7 STX-61511U01C	Clear/ Silver	Letter/ Legal	17.125" × 9.625" × 11"	Each	41.99

\* STX-61510U01C—Contains 50% post-consumer recycled content, 50% total recycled content.

## D PREMIUM FILE CART

Durable plastic and steel cart transports letter size files. Snap lid includes built-in organizer compartment for convenient access to supplies. Telescoping push button handle and rubberized wheels for easy mobility. Manufacturer's limited 90-day warranty.

ID No.	Finish	W × D × H	Shpg. Wt.	Unit	Price
8 STX-61507U01C	Black	15" × 16¾" × 30"	10 lbs.	Each	400.88

\* Contains 25% post-consumer recycled content, 25% total recycled content.

**ADVANTUS**

## E ROLLING 15-GAL. STORAGE BOX

Stack 'em and move 'em. Snap-tight lid features convenient grooves on the top surface so that you can stack boxes without them rolling off. Wheels on bottom allow for hassle-free transport. Clear color makes finding contents easy.

ID No.	Color	Size	W × D × H	Unit	Price
9 AVT-34009	Clear	Letter/Legal	23.75" × 15.75" × 15.75"	Each	60.82

**STOREX**

## G PORTABLE FILE TOTE WITH LOCKING HANDLES

Ergonomically designed handle for easy mobility. Snap-tight, locking lid keeps important letter and legal size hanging files secure and protected. Stackable for convenient storage.

ID No.	Color	Size	W × D × H	Unit	Price
11 STX-61543U01C	Black/ Silver	Letter/ Legal	18.5" × 14.25" × 10.88"	Each	38.87
12 STX-61530U01C	Clear/ Silver	Letter/ Legal	18.5" × 14.25" × 10.88"	Each	38.87

\* STX-61543U01C—Contains 25% post-consumer recycled content, 25% total recycled content.

**ADVANTUS**

## H COMPANION PORTABLE FILE

Industrial grade plastic portable file holder with see-through, hinged lid. Includes easy-lift handles and built-in tracks for letter or legal size hanging file folders (sold separately). Use file alone or set inside Heavy-Duty File Shuttle (AVT-FS-2BHD, sold separately) for easy mobility. 40-lb. capacity.

ID No.	Color	Size	W × D × H	Unit	Price
13 AVT-TLF-2B	Black	Letter/ Legal	17" × 14" × 11"	Each	61.37

## I FILE TOTE WITH LID

A practical solution to your filing needs. Detachable snap-lock lid fits securely. Molded carry handles make for easy transportation. Built-in rails hold letter or legal size hanging file folders (not included).

ID No.	Color	Size	W × D × H	Unit	Price
14 AVT-34052	Black	Letter/ Legal	14.13" × 18" × 10.75"	Each	31.48

**i Innovative storage designs**

## J EXTRA-CAPACITY 28" FILE TOTE

Smart cover design makes stacking simple and provides a secure closure. Lid opens from either side for easy access or can be removed for full access. Molded handles for easy carrying. Holds letter-size hanging file folders (sold separately).

ID No.	Color	Size	W × D × H	Unit	Price
15 AVT-55797	Clear/ Navy	Letter	23.25" × 14.25" × 10.63"	Each	40.88





Legendary Reliability™

## A SMART-UPS® 600 VA BATTERY BACKUP SYSTEM

Stay connected for hours, not minutes. Charge and power more than one device at once. Wider outlet spacing for both high and low power devices. \$75,000 Equipment Protection Policy. Manufacturer's three-year warranty.

ID No.	VA	Outlets	Run Time*	Joules	Dimensions	Unit	Price
1 APW-BE600M1	120 VA	7 UPS/Surge, 2 Surge Only	31 minutes	490 J	10¼" × 4¼" × 5½"	Each	105.00

## B SMART-UPS® 425 VA BATTERY BACKUP SYSTEM

Back up and protect your hardware and data during power outages, surges and spikes. Provides early-warning fault analysis on batteries enabling timely preventive maintenance. Provides notification of changing utility power and UPS power conditions. \$75,000 Equipment Protection Policy. Manufacturer's three-year warranty.

ID No.	VA	Outlets	Run Time*	Joules	Dimensions	Unit	Price
2 APW-BE425M	120 VA	6 UPS/Surge, 2 Surge Only	18 minutes	180 J	10" × 4¼" × 5½"	Each	76.00

## C BACK-UPS® ES SERIES BATTERY BACKUP SYSTEM

Designed to use less energy during normal operation, this backup system provides enough power for you to work through short and medium length power outages. Data line protection safeguards your equipment from damaging surges and spikes that travel along utility and data lines. Four stage LED status display indicates On Line, On Battery, Replace Battery and Building Wiring Fault conditions. Continuous tone and two different chime alerts notify you of changing utility power and UPS conditions. Wide spaced outlets allow you to protect equipment that uses input transformer blocks without blocking access to other receptacles. \$75,000 Equipment Protection Policy. Manufacturer's limited three-year warranty.

ID No.	VA	Outlets	Run Time*	Joules	Dimensions	Unit	Price
3 APW-BE650G1	650 VA	4 UPS/Surge; 4 Surge Only	13 minutes	340 J	12¾" × 7" × 3¾"	Each	127.00

**Includes PowerChute® Auto-Shutdown Software**

*Conforms to UL 1449 Standards; Conforms to UL 1778 Standards; FCC Class B Certified; FCC Part 68 Certified; TUV SUD Certified. Run Time based on a load of 195 watts.*

## D BACK-UPS® CS BATTERY BACKUP SYSTEM

Dataline Surge Protection provides protection of connected equipment on the data lines. Automatic restart of loads after UPS shutdown upon the return of utility power for exceptional convenience. \$100,000 Equipment Protection Policy. Manufacturer's three-year warranty.

ID No.	VA	Outlets	Run Time*	Joules	Dimensions	Unit	Price
4 APW-BK350	350 VA	3 UPS/Surge; 3 Surge Only	21 minutes	1020 J	3¾" × 11½" × 6½"	Each	130.00
5 APW-BK500	500 VA	3 UPS/Surge; 3 Surge Only	15 minutes	480 J	3¾" × 11½" × 6½"	Each	175.00

*APW-BK350—FCC Part 68 Certified; TUV. Run Time based on a load of 105 watts.*

*APW-BK500—cUL Listed; FCC Class B Certified; UL Listed. Run Time based on a load of 150 watts.*



## E ECO SERIES DESKTOP UPS SYSTEMS

Offers complete protection from blackouts, brownouts and transient surges. Supports energy savings via built-in Eco outlets that automatically power off unused computer accessories like printers or multi-media speakers when the computer is not in use. Full load efficiency rating of 99% also offers energy-savings and cooler operation by limiting UPS power consumption. Provides uninterrupted transition to battery-derived AC output during brownouts and power failures with enough runtime to save and shutdown connected equipment without data loss. Offers complete protection in an ultra-compact desktop or wall-mountable housing. USB communication enables UPS configuration options and unattended system shutdown without data loss in the case of extended power failure. \$250,000 Ultimate Lifetime Insurance. Manufacturer's limited three-year warranty.

ID No.	VA	Outlets	Run Time*	Joules	Dimensions	Unit	Price
6 TRP-ECO1000LCD	1000 VA	4 UPS/Surge; 4 Surge Only	40 minutes	316 J	3.9" × 11.33" × 11"	Each	267.00
7 TRP-ECO1500LCD	1440 VA	5 UPS/Surge; 5 Surge Only	90 minutes	316 J	3.9" × 16.14" × 11"	Each	312.00

*Run Time based on single PC load with 15" flat panel monitor.*

*TRP-ECO1000LCD—Energy Star Rated; Meets FCC Part 15 Category B EMI Tested to UL1778.*

*TRP-ECO1500LCD—Energy Star Rated; Meets FCC Part 15 Category B. UL1778.*

## F INTERNET OFFICE™ UPS SYSTEM

Power protection and battery backup for home and office computers and electronics. Provides seamless battery support during brownouts and power failures with enough runtime to save and shutdown connected equipment without data loss. Includes battery supported outlets and additional suppression-only outlets. USB enables optional unattended system shutdown without data loss in the case of extended power failure. PowerAlert software available via free download, includes bundled USB cable. Built-in audible alarm and front panel LEDs offer continuous status information regarding line and battery power operation. \$100,000 Ultimate Lifetime Insurance. Manufacturer's three-year warranty.

ID No.	VA	Outlets	Run Time*	Joules	Dimensions	Unit	Price
8 TRP-INTERNET350U	350 VA	3 UPS/Surge; 3 Surge Only	12 minutes	380 J	8" × 6¾" × 3"	Each	91.26
9 TRP-INTERNET750U	750 VA	6 UPS/Surge; 6 Surge Only	45 minutes	420 J	12¼" × 6¾" × 3¼"	Each	153.43
10 TRP-INTERNET900U	900 VA	6 UPS/Surge; 6 Surge Only	45 minutes	420 J	12¼" × 6¾" × 3¼"	Each	173.23

*Run Time based on single PC load with 15" flat panel monitor.*

*TRP-INTERNET350U—Conforms to UL 1778 Standards; CSA Certified; NOM.*

*TRP-INTERNET750U—CSA Certified; FCC Class B Certified; NOM; RoHS Compliant; UL1778 Listed.*

*TRP-INTERNET900U—CSA Certified; Energy Star Rated; FCC Class B Certified; NOM; RoHS Compliant; UL1778 Listed.*

A



## A MEDICAL-GRADE POWER STRIP FOR PATIENT CARE AREAS

Supplies power to movable plug-connected components mounted to a rack, table or pedestal in operating rooms, patient-care vicinities, therapy rooms, imaging environments and administrative areas. Two built-in resettable 15A circuit breakers control power to all outlets and protect the power strip against overloads. Switchless design prevents the unit from being accidentally shut off. Power cord provides ample reach to the power source and all-metal housing ensures safety and is guaranteed to last a long time in demanding environments. Manufacturer's limited lifetime warranty.

ID No.	Outlets	Cord Length	Color	Unit	Price
1 TRP-PS615HG0EM *	6	15 ft	White	Each	124.00

\* Conforms to UL 1363 Standards.

B



## B PROTECT IT!™ SEVEN-OUTLET SURGE SUPPRESSOR

Protect workstations, desktop PCs and other sensitive electronics from surges and line noise with this surge suppressor. Transformer-friendly design accommodates at least one large transformer plug without covering remaining outlets. Features Diagnostic LEDs to confirm outlet grounding and surge suppression status. Manufacturer's limited lifetime warranty.

ID No.	Outlets	Multimedia Protection	Joules	Cord Length	Color	Equipment Insurance	Unit	Price
2 TRP-SUPER7TEL15 *	7	Tel/Modem	2520 J	15 ft	Light Gray	\$75,000	Each	60.00
3 TRP-SUPER7B *	7	....	2160 J	7 ft	Black	\$75,000	Each	29.40
4 TRP-SUPER7 *	7	....	2160 J	7 ft	Light Gray	\$75,000	Each	29.40
5 TRP-STRIKER *	7	....	1080 J	6 ft	Light Gray	\$20,000	Each	28.40
6 TRP-TLP712B *	7	....	1080 J	12 ft	Black	\$25,000	Each	33.19
7 TRP-TLP712 *	7	....	1080 J	12 ft	Light Gray	\$25,000	Each	33.19
8 TRP-TLP725 *	7	....	1080 J	25 ft	Light Gray	\$25,000	Each	55.99

Right Angle Design—Features six right-angle outlets and one designated transformer outlet.

9 TRP-TLP74RB *	7	....	1080 J	4 ft	Black	\$25,000	Each	21.19
-----------------	---	------	--------	------	-------	----------	------	-------

\* TRP-SUPER7TEL15—cUL Listed; FCC Certified; IEEE 587 Category A & B Approved; UL Listed.

TRP-SUPER7B—Conforms to UL 1363 Standards; Conforms to UL 1449 Standards; cUL Approved; Exceeds IEEE 587 category A & B specifications.

TRP-SUPER7—cUL Listed; UL Listed.

TRP-STRIKER, TRP-TLP712, TRP-TLP725—cUL Listed; IEEE 587 Category A & B Approved; NOM; NOM (Mexico); RoHS Compliant; UL Listed.

TRP-TLP712B—cUL Listed; IEEE 587 Category A & B Approved; NOM; RoHS Compliant; UL Listed.

TRP-TLP74RB—Conforms to UL 1363 Standards; Conforms to UL 1449 Standards; cUL Approved; IEEE 587-A/B.

C



## C PROTECT IT!™ SIX-OUTLET SURGE SUPPRESSOR

Protect all electronics from damage and performance problems due to surges and spikes. Transformer-friendly design accommodates at least one large transformer plug without covering remaining outlets. Diagnostic LED warns of suppressor damage. Keyhole mounting tabs offer convenient protection of desktop computer equipment and accessories. Manufacturer's limited lifetime warranty.

ID No.	Outlets	Multimedia Protection	Joules	Cord Length	Color	Equipment Insurance	Unit	Price
10 TRP-TLP606DMUSB *	6; 2 USB	....	2100 J	6 ft	Black	\$40,000	Each	48.40
11 TRP-TLM606HJ *	6	....	1340 J	6 ft	Light Gray	\$75,000	Each	37.39
12 TRP-TLP608RUSBB *	6; 2 USB	....	1080 J	8 ft	Black	\$50,000	Each	67.00
13 TRP-TLP606USB *	6; 2 USB	....	990 J	6 ft	Cool Gray	\$20,000	Each	32.40
14 TRP-TLP604 *	6	....	790 J	4 ft	Light Gray	\$20,000	Each	16.63
15 TRP-TLP604TEL *	6	Tel/Modem	790 J	4 ft	Light Gray	\$20,000	Each	18.21
16 TRP-TLP606B *	6	....	790 J	6 ft	Black	\$20,000	Each	18.19
17 TRP-TLP606 *	6	....	790 J	6 ft	Light Gray	\$20,000	Each	18.19
18 TRP-TLP615 *	6	....	790 J	15 ft	Light Gray	\$20,000	Each	36.98
19 TRP-TLP602 *	6	....	180 J	2 ft	Light Gray	\$2,500	Each	11.84

\* Conforms to UL 1363 Standards; Conforms to UL 1449 Standards; cUL Approved; RoHS Compliant.

D



## D SIX-OUTLET HOME/OFFICE SURGE PROTECTOR

Protects electronics from harmful power fluctuations, such as surges and spikes. Provides the convenience of much-needed additional outlets. Heavy-duty cord and quality construction ensure long-lasting protection. Manufacturer's limited lifetime warranty.

ID No.	Outlets	Joules	Cord Length	Color	Equipment Insurance	Unit	Price
20 BLK-BE106000-04 *	6	720 J	4 ft	White	\$15,000 Limited	Each	21.96
21 BLK-BE106000-10 *	6	720 J	10 ft	White	\$15,000 Limited	Each	33.27
360° Rotating Plug							
22 BLK-BE106000-08R *	6	720 J	8 ft	White	\$15,000 Limited	Each	25.24

\* cUL Listed; UL Listed.



### A 3.3 CU. FT. REFRIGERATOR WITH CHILLER COMPARTMENT

Counter-height fridge is ideal for breakrooms, offices or household use. Lightweight, quiet, easy-to-use, low-electric consumption refrigerator is perfect in any small space. Chiller compartment with door for short-term storage of frozen items. Left or right opening configurable door. Manufacturer's limited one-year warranty. 

ID No.	Color	W x D x H	Unit	Price
1 ALE-RF333B ★	Black	18¾" x 17¼" x 33¼"	Each	469.00

★ Energy Conservation Standard Compliant; Energy Star Rated; UL Approved.

### B 1.6 CU. FT. REFRIGERATOR WITH CHILLER COMPARTMENT

Compact sized mini-fridge is perfect for light-duty or personal use. Lightweight, quiet, easy-to-use, low-electric consumption refrigerator is perfect in any small space. Chiller compartment with door for short-term storage of frozen items. Reversible doors can be installed left or right to fit any configuration. Manufacturer's limited one-year warranty. 

ID No.	Color	W x D x H	Unit	Price
2 ALE-RF616B ★	Black	18¾" x 17¼" x 19¾"	Each	349.00

★ Energy Conservation Standard Compliant; Energy Star Rated; UL Approved.

### C 3.2 CU. FT. BEVERAGE COOLER

Sleek stainless steel beverage cooler keeps beverages cool and easily available. Convenient triple layer glass front door is frost-free, to better showcase drink choices. Convenient cooler provides plenty of storage, with three adjustable shelves. Holds up to 120 cans. Reversible doors can be installed left or right to fit any configuration. Comes with full-range temperature control and interior light. Quiet, low-energy consumption refrigerator/cooler is perfect in any space. Leveling glides help compensate for uneven floors. Flush back design conceals components and allows a seamless fit in tight spaces. Manufacturer's limited one-year warranty. 

ID No.	Color	W x D x H	Unit	Price
3 ALE-RFBC34 ★	Stainless Steel/Black	19¾" x 17¼" x 33¼"	Each	639.00

★ CSA Energy Efficiency Mark; Energy Conservation Standard Compliant; Energy Star Rated; Energy Star Rated; UL Approved.



### D 5.5 CU. FT. SIDE BY SIDE REFRIGERATOR/FREEZER

Side-by-Side Refrigerator/Freezer offers a generous 5.5 cubic foot capacity. The refrigerator section has a 3.3 CF capacity, with a 2.2 CF freezer. Attractive black cabinet with platinum-finish doors and molded decorator is the perfect addition to any kitchen or office. Manufacturer's one-year parts and labor warranty. 

ID No.	Color	W x D x H	Unit	Price
4 AVA-RMS551SS ★	Black/Platinum Finish	31" x 23" x 33½"	Each	662.00

★ Energy Star Rated; Meets 2014 DOE Standards.

### E BOTTOM MOUNTED FROST-FREE FREEZER/REFRIGERATOR

Refrigerator with modern European design creates a pleasant presentation, with plenty of storage space. Includes full-range temperature control, removable/adjustable shelving in refrigerator, wire shelf and storage basket in freezer. Top and bottom doors are reversible for left or right opening. Refrigerator features dual crisper with glass lid and two-liter bottle storage on door. Beverage can dispenser holds up to six 12-oz. cans. 

ID No.	Color	W x D x H	Unit	Price
5 AVA-FFBM92H0W	White	23¾" x 26¾" x 59¾"	Each	1,396.11

### F 4.4 CU. FT. REFRIGERATOR

Convenient mini-fridge has adjustable slide-out shelves, so you can arrange the contents just the way you want them. Contains one full-width and two half-width door storage bins. A gallon-jug storage area in the lower door bin is perfect for larger bottles. A full-width chiller compartment is perfect for frozen meals and ice cream. Adjustable thermostat control with a push-button defrost mode. Leveling legs are adjustable, to accommodate odd or uneven flooring and a flat-back design allows for easy placement. An interior light makes it easy to grab what you want, even at night. Convenient reversible door. 

ID No.	Color	W x D x H	Unit	Price
6 AVA-RM4436SS ★	Black/Stainless	19½" x 22" x 33"	Each	566.76

★ Energy Star Rated.

### G 4.4 CU. FT. AUTO-DEFROST REFRIGERATOR

Convenient miniature refrigerator with slide-out glass shelves for easy restocking. Plenty of storage, with one full-width and two half-width door storage bins, with gallon-jug storage in lower door bin. It also features storage on the door for up to six cans. 

ID No.	Color	W x D x H	Unit	Price
7 AVA-AR4446B ★	Black	19½" x 22" x 33"	Each	561.76

★ Energy Star Rated.

### H 3.3 CU. FT. REFRIGERATOR WITH CHILLER COMPARTMENT

Interior includes two removable, adjustable glass shelves. 2 liter bottle storage in door. Full range temperature control and a reversible door. Chiller compartment for short-term storage. 

ID No.	Color	W x D x H	Unit	Price
8 AVA-RM3316B ★	Black	18½" x 17½" x 33½"	Each	450.00
9 AVA-RM3306W ★	White	18½" x 17½" x 33½"	Each	447.42

★ Energy Star Rated.

### I COUNTER-HEIGHT 3.1 CU. FT. TWO-DOOR REFRIGERATOR/FREEZER

Attractive counter-high unit features a space-saving flush-back design. Full-range temperature control allows you to tailor operation to fit your needs. Handy in-door can dispenser accommodates up to five 12-oz cans. Reversible doors. Manufacturer's one-year parts and labor warranty. 

ID No.	Color	W x D x H	Unit	Price
10 AVA-RA31B3S ★	Black/Stainless Steel	18¾" x 18¾" x 33½"	Each	640.99

★ Energy Star Rated.

# Office Furnishings Stands & Carts/Computer & Monitor



Mahogany

Designed for oversized office equipment.



Black



**B**  
Desk-Side

Black/  
Cherry

Black/  
Cherry

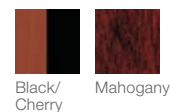

Black/  
Cherry

Mahogany



**C**  
Underdesk



Black



Black

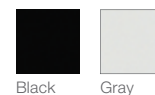

Black

Gray



## A MOBILE LAMINATE MACHINE STAND WITH OPEN COMPARTMENT

Double door cabinet, with contemporary black pulls, provides concealed storage. Stain- and scratch-resistant 3/4" laminate on furniture-grade wood construction. Four Casters, two locking. Designed for fax, printer or copier. Top rear of unit has 4" opening for cable routing. Storage shelf has grommet cut-out for cable routing into lower cabinet. Lower Storage Compartment: 26w x 17 1/4d x 14 1/4h; Upper Compartment: 26w x 17 1/4d x 9 1/4h.

ID No.	Finish	W x D x H	Shpg. Wt.	Unit	Price
1	SAF-1850MH *	Mahogany 28" x 19 1/4" x 30 1/2"	81 lbs.	Each	<del>521.00</del>

\* Contains 80% total recycled content.

## B - C IMPROMPTU™ MACHINE STANDS

Contemporary machine stand, featuring a steel, powder coat frame for durability and translucent polycarbonate panels, to complement any work environment. Generously sized laminate top accommodates most office machines. Four casters (two locking). Free up desk space and keeps additional printing supplies close at hand. Large storage area with one fixed shelf.

ID No.	Finish	W x D x H	Shpg. Wt.	Unit	Price
2	SAF-1857BL *	Black/Cherry 26 1/4" x 21" x 26 1/2"	41 lbs.	Each	<del>364.00</del>

### C UNDERDESK STAND

3	SAF-1862BL *	Black/Cherry 20 1/2" x 16 1/2" x 14 1/2"	20 lbs.	Each	<del>243.00</del>
---	--------------	--	---------	------	-------------------

\* GREENGUARD Certified.



## D DELUXE STEEL MACHINE STAND

Designed for oversized office equipment. Double door cabinet with one fixed shelf for supplies. Black with laminate top and metallic gray legs. Manufacturer's limited lifetime warranty.

ID No.	Finish	W x D x H	Shpg. Wt.	Unit	Price
4	SAF-1872BL	Black 32" x 24 1/2" x 30 1/4"	63 lbs.	Each	<del>600.00</del>

## E DESK SIDE WIRE MACHINE STAND

The steel frame and a powder coat finish makes this machine stand a durable organization solution. Featuring two sturdy shelves to hold paper, supplies or snacks and is perfect for common work areas or meeting spaces. It's also mobile on four swivel casters, (2 locking). Stand holds up to 200 lbs. Manufacturer's limited lifetime warranty.

ID No.	Finish	W x D x H	Shpg. Wt.	Unit	Price
5	SAF-5207BL	Black 24" x 20" x 27"	33 lbs.	Each	<del>401.00</del>

## F UNDERDESK PRINTER/FAX STAND

Large surface provides ample space for most printers and fax machines. Sturdy steel wire shelf is ideal for storing extra paper or supplies. Low profile design allows storing under desk when not in use. Easy assembly, no tools required. Manufacturer's limited lifetime warranty.

ID No.	Finish	W x D x H	Shpg. Wt.	Unit	Price
6	SAF-5206BL	Black 19" x 16" x 13 1/2"	19 lbs.	Each	<del>126.00</del>
7	SAF-5206GR	Gray 19" x 16" x 13 1/2"	19 lbs.	Each	<del>126.00</del>





### A 3-IN-1 CART & STAND

Clever all-in-one design can be used as a utility cart, monitor stand, and/or printer cart. Includes 3 shelves, stacking columns, drawer and casters which can be configured any way you need such as a 2 or 3-tier cart and/or a single or double-shelf stand. Accommodates printers up to 75lbs. Manufacturer's limited five-year warranty.

ID No.	Finish	W x D x H	Shpg. Wt.	Unit	Price
1 ALE-U3N1BL	Black/Gray	21½" x 13¾" x 24¾"	14 lbs.	Each	<del>409.00</del>



### B - C SCOOT™ PRINTER STAND

Frees up desk space and keeps additional printing supplies close at hand. Accommodates most desktop printers and other small office machines. Manufacturer's limited lifetime warranty.

ID No.	Finish	W x D x H	Shpg. Wt.	Unit	Price
--------	--------	-----------	-----------	------	-------

**B DESK SIDE STAND**—One height-adjustable shelf and an adjustable pocket for active files. Inner shelves hold up to 50 lbs. each; top supports up to 100 lbs.

2 SAF-1856BL	Black/Silver	26½" x 20½" x 26½"	45 lbs.	Each	<del>290.00</del>
--------------	--------------	--------------------	---------	------	-------------------

**C UNDERDESK STAND**—Hides printers and small office machines under most work surfaces.

3 SAF-1855BL	Black/Silver	20¼" x 16½" x 14½"	19 lbs.	Each	<del>147.00</del>
--------------	--------------	--------------------	---------	------	-------------------

### D ONYX UNDER DESK MACHINE STAND

Mobile cart on four swivel casters with two locking, slides easily under desk or work surface when not in use to save space.

ID No.	Finish	W x D x H	Shpg. Wt.	Unit	Price
--------	--------	-----------	-----------	------	-------

**2-Shelf Desk Machine Stand**—Wood laminate shelves with mesh baskets.

4 SAF-5208BL	Black	21" x 16" x 17½"	23 lbs.	Each	<del>212.00</del>
--------------	-------	------------------	---------	------	-------------------

5 SAF-5208WH	White	21" x 16" x 17½"	25 lbs.	Each	<del>212.00</del>
--------------	-------	------------------	---------	------	-------------------

### E - F WAVE DESIGN PRINTER STAND

Gray shelves accented with charcoal columns. Contemporary wave design shelves. Storage for paper, ink cartridges, envelopes and more. Easy to assemble. Manufacturer's limited lifetime warranty.

ID No.	Finish	W x D x H	Shpg. Wt.	Unit	Price
--------	--------	-----------	-----------	------	-------

**E DESK SIDE STAND**—Three shelves.

6 SAF-1860GR *	Charcoal Gray	20" x 17½" x 29¼"	18 lbs.	Each	<del>161.00</del>
----------------	---------------	-------------------	---------	------	-------------------

**F UNDERDESK STAND**—Two shelves. Tucks under most work surfaces to save valuable floor space.

7 SAF-1861GR *	Charcoal Gray	20" x 17½" x 11½"	11 lbs.	Each	<del>101.00</del>
----------------	---------------	-------------------	---------	------	-------------------

\* GREENGUARD Certified.

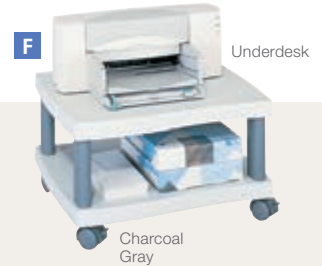

### G MOBILE PRINTER STAND

Stores printer under desk to save space. Accommodates most printers up to 18" x 18" and supports up to 75 lbs. Made of heavy-gauge, static dissipating steel. Two built-in power strip holders in the lower shelf for convenient AC access (power strips sold separately). Shelf dimensions: 17w x 17d.

ID No.	Finish	W x D x H	Shpg. Wt.	Unit	Price
--------	--------	-----------	-----------	------	-------

**Two-Shelf**

8 MAT-24050	Platinum	17½" x 17¼" x 8½"	16 lbs.	Each	<del>147.10</del>
-------------	----------	-------------------	---------	------	-------------------



### H DESKSIDE MACHINE STAND

Durable steel and wire construction. Two shelves, one adjustable, help keep supplies close at hand.

ID No.	Finish	W x D x H	Shpg. Wt.	Unit	Price
--------	--------	-----------	-----------	------	-------

9 VRT-VF52004	Matte Gray	21½" x 17¼" x 27"	28 lbs.	Each	<del>210.35</del>
---------------	------------	-------------------	---------	------	-------------------

### I UNDERDESK MACHINE STANDS

Durable steel and wire construction. Handy bottom shelf keeps supplies close at hand. Two surface grommets help route cords and cables; can also be used as a handle to pull stand from beneath worksurface.

ID No.	Finish	W x D x H	Shpg. Wt.	Unit	Price
--------	--------	-----------	-----------	------	-------

10 VRT-VF52009	Black	21½" x 17¼" x 11½"	15 lbs.	Each	<del>120.33</del>
----------------	-------	--------------------	---------	------	-------------------

11 VRT-VF52005	Matte Gray	21½" x 17¼" x 11½"	15 lbs.	Each	<del>120.33</del>
----------------	------------	--------------------	---------	------	-------------------

Prices subject to change without notice.

Visit our website for the latest pricing and product information.

# Office Furnishings Stands & Carts/Computer & Monitor



## A METAL MONITOR RISER

Elevate your monitor to a proper eye position to reduce eyestrain while working. Industrial metal look and U-shaped legs blends nicely with any home or office. Non-skid rubber pads protect work surface from scratches or scuffs.

ID No.	W x D x H	Color	Unit	Price	
1	IVR-55005	14 5/8" x 9 1/4" x 4"	Black	Each	34.49

## B SINGLE LEVEL MONITOR RISER

Elevates monitor to provide a more comfortable viewing level. Cable manager in the back keep cords tangle-free. Constructed from strong durable plastic. Non-skid rubber feet protects surface. Fits most flat panel monitors up to 24".

ID No.	W x D x H	Color	Unit	Price	
2	IVR-55010	13 1/4" x 13 1/2" x 4"	Black	Each	21.99

## C SLIM ALUMINUM MONITOR RISER

Ultra-slim construction and sleek design add a clean and stylish look to any home or office. This monitor stand elevates your monitor to a proper eye position to reduce your eye and neck fatigue. Free up space by storing your keyboard and mouse under the riser. Non-skid silicone pads protect work surfaces from scratches or scuffs. Supports up to 44 lbs.

ID No.	W x D x H	Color	Unit	Price	
3	IVR-55015	15 3/4" x 8 1/4" x 2 1/2"	Silver	Each	51.74

## D ADJUSTABLE TEMPERED GLASS MONITOR RISER

Elevate your monitor to a proper eye position with this sleek looking tempered glass monitor riser. Adjustable stainless steel feet allow the user to rise or lower their monitor riser easily and provides increased storage room beneath the desktop. Supports up to 44 lb. and screen sizes of 13"-22".

ID No.	W x D x H	Color	Unit	Price	
4	IVR-55020	15 3/4" x 9 1/2" x 3 1/2"	Clear; Silver	Each	28.74
5	IVR-55025	22 3/4" x 8 1/4" x 3 1/2"	Clear; Silver	Each	34.49

## E LARGE MONITOR STAND WITH CABLE MANAGEMENT AND DRAWER

Set your monitor at an ergonomically correct height and maximize desk space with our height-adjustable smart stand. This stand features a contemporary design with stacking columns, letting you choose the ideal height for your monitor. With ample clearance between the stacking columns, this stand provides plenty of room to fit a small laptop or supplies beneath. A non-skid column base and 22 lb. of each shelf support help to ensure your monitor or other electronic devices rest securely while you work. Built-in cable organizer and drawer maximize desktop space and minimize clutter. Accommodates most 13"-32" monitors, laptop, printers, and other office machines.

ID No.	W x D x H	Color	Unit	Price	
6	IVR-55050	18 3/8" x 13 3/8" x 5"	Black	Each	45.99

## F LARGE MONITOR STAND WITH CABLE MANAGEMENT

Set your monitor at an ergonomically correct height and maximize desk space with our height-adjustable smart stand. This stand features a contemporary design with stacking columns, letting you choose the ideal height for your monitor. With ample clearance between the stacking columns, this stand provides plenty of room to fit a small laptop or supplies beneath. A non-skid column base and 22 lbs. of support help to ensure your monitor or other electronic devices rest securely while you work. It also features cable management that keeps cords in place.

ID No.	W x D x H	Color	Unit	Price	
7	IVR-55051	12.99" x 17.1" x 6.6"	Black	Each	28.74

## G BASIC LCD MONITOR/PRINTER STAND

Elevated platform surface raises monitors or printers off your desktop. Buy more than one and stack. Accessory drawer with adjustable, removable drawer dividers offers extra storage for supplies. Nonskid rubber feet.

ID No.	W x D x H	Color	Unit	Price	
8	IVR-55000	15" x 11" x 3"	Charcoal Gray/Light Gray	Each	31.11



## H MONITOR STAND

Extra-large platform accommodates monitor, laptop or printer. Adjustable height. Raises LCD or CRT monitor or laptop to a comfortable viewing level. 40 lb. capacity; suitable for monitor up to 32". Cable management.

ID No.	W x D x H	Color	Unit	Price	
<b>Single Level Stand—Adjusts from 3" to 6 1/2"</b>					
9	KTK-MS400	17" x 13 1/4" x 3" - 6 1/2"	Black	Each	34.99
<b>Single Level Stand With Organizing Drawer—Adjusts from 3" to 6 1/2"</b>					
10	KTK-MS420	17" x 13 1/4" x 3" - 6 1/2"	Black	Each	44.99
<b>Two Level Deluxe Stand With Organizing Drawer—Adjusts from 3 1/2" to 7"</b>					
11	KTK-MS480	17" x 13 1/4" x 3 1/2" - 7"	Black	Each	54.99

\* Contains 30% post-consumer recycled content, 30% total recycled content.



## I ADJUSTABLE HEIGHT MONITOR STAND

Adjusts to ensure correct ergonomic positioning. Large platform supports monitor, laptop or printer up to 80 lbs. Features 11" of storage space underneath to maximize desk space.

ID No.	W x D x H	Color	Unit	Price	
<b>Adjusts from 1" to 5 1/2"</b>					
12	MMM-MS80B	15" x 12" x 2 5/8" - 5 1/2"	Black/Silver	Each	55.57

## J EXTRA-WIDE ADJUSTABLE MONITOR STAND

Accommodates a laptop below and also works for printers, providing storage below. Holds up to 40 lbs. Adjusts in 1" increments.

ID No.	W x D x H	Color	Unit	Price	
<b>Adjusts from 1" to 5 1/4"</b>					
13	MMM-MS90B	20" x 12" x 1" to 5 1/4"	Silver/Black	Each	61.12



## K SMARTFIT® MONITOR STANDS

Helps you position your monitor at the correct height without need for a specialist, reducing neck, back and eye strain. The stand has three height settings and leaves storage space under the platform to maximize your desktop surface area.

ID No.	W x D x H	Color	Unit	Price	
14	KMW-52785	12 1/4" x 2 1/4" x 4 3/4"	Black	Each	50.48

\* TAA Compliant.

# Stands & Carts/Computer & Monitor Office Furnishings



## A MOBILE CPU STAND

Width adjusts from 6" to 10¼". Nonskid padding holds CPU in place. High-impact plastic construction. Manufacturer's limited one-year warranty.

ID No.	W × D × H	Unit	Price
1 IVR-54001	8¾" × 10" × 5"	Each	<del>19.99</del>

## B METAL MOBILE CPU STAND

Accommodates a CPU up to 9" wide. Sturdy metal construction. Nonskid padding holds CPU in place. Easily mobile on four casters (two locking). Manufacturer's limited one-year warranty.

ID No.	W × D × H	Unit	Price
2 IVR-54000	10¼" × 10¾" × 9¾"	Each	<del>26.02</del>



## C CPU COMPUTER MOUNT

Save valuable desk, table and floor space by securing your computer to a wall, desk or rail. Ideal for home, school and office use beneath, above or adjacent to your workstation. Fits most CPUs from 4 to 6.25 inches wide. Adjustable open frame allows easy access to the CPU and its cabling. Durable all-metal unit supports up to 40 pounds. Manufacturer's limited five-year warranty.

ID No.	For Monitors (Size, Weight)	Weight	Unit	Price
3 TRP-DCPU1	4" - 6¼"; Up to 40 lbs	4.4 lbs.	Each	<del>73.99</del>



## D PROFESSIONAL SERIES UNDERDESK CPU SUPPORT

Offers hassle-free, space-saving storage for CPUs. Protective unit mounts underneath workstation to shield CPU from dirt, dust, bumps or accidental spills. Adjusts to fit CPUs 3¼" to 9" wide and 10½" to 18" tall. For quick, easy access to cables and ports, the CPU holder rotates a full 360° or slides out from under your desk using the easy-grip handle, then slides back out of sight on the smooth 16" track. Powder coated steel for strength and durability. 100% Recyclable. Manufacturer's limited lifetime warranty.

ID No.	W × D × H	Capacity	Unit	Price
4 FEL-8036201	17" × 12" × 11"	40 lbs.	Each	<del>226.59</del>



## E METAL ART™ PRINTER AND MONITOR STAND PLUS

A multi-purpose desktop organization and ergonomic system. Forged from powder coated steel, it provides a wide raised surface for your printer or monitor with an accessory shelf for paper, printer supplies or even your laptop. Perforated hole pattern for passive airflow to keep your electronics cool. The stand features a large 18" × 13.5" platform.

ID No.	W × D × H	Color	Unit	Price
5 ASP-31863	18" × 13.5" × 6"	Black	Each	<del>59.99</del>

## F METAL ART™ DESKTOP PRINTER/MONITOR STAND

Maximizes desk space by raising monitor to comfortable height. Built-in shelf provides extra space above and underneath for paper and supplies. Protective nonslip feet keeps stand in place. Durable construction ensures extra support up to 50 pounds.

ID No.	W × D × H	Color	Unit	Price
6 ASP-27873	18½" × 12" × 5¾"	Pewter	Each	<del>78.99</del>



## G MOBILE PRINTER STAND

Stores printer under desk to save space. Accommodates most printers up to 18" × 18" and supports up to 75 lbs. Made of heavy-gauge, static dissipating steel. Two built-in power strip holders in the lower shelf for convenient AC access (power strips sold separately). Shelf dimensions: 17w × 17d. Four dual-wheel hooded casters.

ID No.	Finish	W × D × H	Shpg. Wt.	Unit	Price
<b>Two-Shelf</b>					
7 MAT-24050	Platinum	17¾" × 17¾" × 9"	16 lbs.	Each	<del>147.10</del>



## H OFFICE SUITES™ PRINTER/MACHINE STAND

Multipurpose design supports a fax machine, printer or scanner. Large drawer holds a full ream of letter or legal size paper. Nonslip feet prevent scratching. Supports up to 50 pounds.

ID No.	W × D × H	Color	Unit	Price
8 FEL-8032601	21¼" × 18¼" × 5¼"	Black/Silver	Each	<del>75.99</del>



## I MOBILE PRINTER STAND

Space-saving unit stores printer, paper and accessories. Reinforced shelves accommodate most laser or inkjet printers. Handy cable management feature keeps cords under control. Easy assembly with no tools required. Height adjusts in ¼" increments for personal comfort level. Four casters (2 locking). Manufacturer's limited one-year warranty.

ID No.	Finish	W × D × H	Shpg. Wt.	Unit	Price
<b>Three-Shelf Stand</b> —Desk-side stand includes organizing storage drawer for supplies. Height adjusts from 19¾" to 24½" in ¼" increments.					
9 KTK-PS540	Black	17" × 13¼" × 24½"	12 lbs.	Each	<del>99.99</del>
10 KTK-PS640	Black	20" × 13¼" × 24½"	13 lbs.	Each	<del>119.99</del>
<b>Two-Shelf Stand</b> —Height adjusts from 11¾" to 14½" in ¼" increments; stows under desk to conserve floor space.					
11 KTK-PS510	Black	17" × 13¼" × 14½"	7 lbs.	Each	<del>67.99</del>
12 KTK-PS610	Black	20" × 13¼" × 14½"	8 lbs.	Each	<del>79.99</del>

**KTK-PS540, KTK-PS510, KTK-PS610, KTK-PS640**—Contains 30% post-consumer recycled content, 30% total recycled content.

Prices subject to change without notice.  
Visit our website for the latest pricing and product information.

# Office Furnishings Signs



## A DURAFRAME® SUN SIGN HOLDER

The sun inf rame is for glass surfaces exposed to sunlight for information and advertising on shop windows and car windows. Four-sided frame works horizontally or vertically. When applied to glass information can be read from both sides. Heat resistant up to 70°C. UV-stabilized for up to 2 years. Available for letter- or tabloid-size documents. Removable and repositionable without residue.

ID No.	Color	Material	Insert W x H	Qty	Unit	Price
1 DBL-400023	Silver	PVC	8½ x 11	2	Pack	34.95
2 DBL-400123	Silver	PVC	11 x 17	2	Pack	49.95

## B DURAFRAME® MAGNETIC PLUS SIGN HOLDER

The magnetic folding inf rame is the ideal solution for protecting documents from dust and moisture in production and sanitary areas. Four-sided frame works horizontally or vertically. Sturdy cover pulls back effortlessly for speedy insert update. With additional back panel to securely hold documents in letter size format. Easy to attach to metal surfaces such as filing cabinets, metal walls in production areas and whiteboards.

ID No.	Color	Material	Insert W x H	Qty	Unit	Price
3 DBL-400423	Silver	PVC	8½ x 11	2	Pack	23.95

## C DURAFRAME® MAGNETIC SIGN HOLDER

Magnetic inf rame displays documents on metallic surfaces in production area and offices, such as whiteboards, metal cabinets, racking and machinery. Four-sided frame works horizontally or vertically. Sturdy cover pulls back effortlessly for speedy insert updates. Anti-glare plastic.

ID No.	Color	Material	Insert W x H	Qty	Unit	Price
4 DBL-472101	Black	PVC	5½ x 8½	2	Pack	12.95
5 DBL-472123	Silver	PVC	5½ x 8½	2	Pack	12.95
6 DBL-477101	Black	PVC	8½ x 11	2	Pack	17.95
7 DBL-477123	Silver	PVC	8½ x 11	2	Pack	17.95

## D DURAFRAME® SECURITY MAGNETIC SIGN HOLDER

Dual-colored magnetic inf rame for all types of safety and warning information. Attaches to metallic surfaces such as whiteboards, metal cabinets, racking and machinery. Four-sided frame works horizontally or vertically. Sturdy cover pulls back effortlessly for speedy insert updates of safety markings, direction and warning signs such as escape and rescue routes and more.

ID No.	Color	Material	Size	Qty.	Unit	Price
8 DBL-4772131	Green/White	PVC	8½ x 11	2	Pack	20.95
9 DBL-4772132	Red/White	PVC	8½ x 11	2	Pack	20.95
10 DBL-4772130	Yellow/Black	PVC	8½ x 11	2	Pack	20.95

## E DURAFRAME® NOTE SIGN HOLDER

The self-adhesive inf rame with pen holder is the ideal solution for direct writing on documents and notices. Quick insertion and exchange of documents via a fold-back magnetic frame. Easy to attach to solid and smooth surfaces. Can be removed from glass. Direct writing onto the inserts within the frame. Universal pen holder. Frame looks identical from both sides. For use in portrait and landscape formats. Can be to create cleaning charts in public toilets, registration for events or collection and documentation of information, working procedures and services such as maintenance or safety checks.

ID No.	Color	Material	Size	Qty.	Unit	Price
11 DBL-477323	Silver	PVC	8½ x 11	1	Each	14.45

## F DURAFRAME® SELF-ADHESIVE SIGN HOLDER

Self-adhering display sign with hinged magnetic front lets you create professional looking signage/displays quickly and easily. Adheres to any smooth and solid surface. Simply peel, stick and you're done. Sturdy cover lifts effortlessly, allowing for speedy insert updates. Magnetic seal holds inserts securely in place. Can be read from both sides when affixed to transparent surfaces, such as glass. Frame looks identical from both sides. Can be used in both portrait and landscape formats.

ID No.	Color	Material	Insert W x H	Qty	Unit	Price
12 DBL-491301	Black	PVC	5½ x 8½	2	Pack	15.45
13 DBL-476801	Black	PVC	8½ x 11	2	Pack	19.95
14 DBL-476803	Red	PVC	8½ x 11	2	Pack	19.95
15 DBL-476823	Silver	PVC	8½ x 11	2	Pack	19.95
16 DBL-476901	Black	PVC	11 x 17	2	Pack	28.95

# universal.

## G CLEAR 2-SIDED T-STYLE FREESTANDING FRAME

Perfect for sales counters, reception desks, conference displays and more. Double-sided T-style design helps ensure that your important information gets maximum exposure. Made entirely of durable, shatter-proof clear material. Manufacturer's limited one-year warranty.

ID No.	Color	Material	Insert W x H	Qty	Unit	Price
17 UNV-76859	Clear	Plastic	4 x 6	2	Pack	7.11
18 UNV-76863	Clear	Plastic	8 x 10	2	Pack	24.38
19 UNV-76864	Clear	Plastic	8½ x 11	2	Pack	31.04

## H CLEAR L-STYLE FREESTANDING FRAME

Ideal for displaying information in schools, restaurants, reception areas and more. Freestanding, angled L-style design for easy-viewing. Made entirely of durable, shatter-proof material.

ID No.	Insert Size	Frame Color	Qty.	Unit	Price
20 UNV-76858	4 x 6	Clear	3	Pack	7.37
21 UNV-76850	5 x 7	Clear	3	Pack	11.91
22 UNV-76851	8 x 10	Clear	3	Pack	24.38
23 UNV-76852	8½ x 11	Clear	3	Pack	32.19

## I WALL MOUNT SIGN HOLDER

This wall mounted horizontal/landscape sign holder keeps signage neat and clean and protects it from damage. Features pre-drilled holes for easy wall mounting and includes two mounting screws. Signage loads from the top and can be easily changed without removing sign holder from wall. Durable plastic construction. Multi-pack includes two wall signs with mounting screws. Manufacturer's limited one-year warranty.

ID No.	Color	Material	Insert W x H	Qty	Unit	Price
24 UNV-76882	Clear	Plastic	8½ x 11	2	Pack	18.14
25 UNV-76883	Clear	Plastic	11 x 8½	2	Pack	18.14

## J MINI TABLE-TOP SIGN

These mini table top clear sign holders are ideal for a variety of uses. They will stand either horizontally or vertically and are great for displaying product and marketing details, pricing and other information. Includes blank paper inserts for creating individual signage. Durable clear styrene construction protects signage from dirt and damage. Multi-pack includes 10 mini sign holders and 10 blank inserts. Manufacturer's limited one-year warranty.

ID No.	Color	Material	Insert W x H	Qty	Unit	Price
26 UNV-76861	Clear	Plastic	1½ x 2	10	Pack	10.99





## PEOPLE POINTER™ A Perfect Sign Every Time

### A WALL/DOOR SIGN

Design your own wall or door sign in just minutes with the easy-to-use "Do-it-Yourself" sign. Use web-based templates to create the customized insert. Includes double-sided tape. Lightweight aluminum frame. Patented design.

ID No.	Color	Material	Size	Qty.	Unit	Price
1 AVT-75390	Black/Silver	Lightweight Aluminum	8½ × 3¼	1	Each	<del>19.95</del>

## ADVANTUS

### B PANEL WALL SIGN HOLDER

Design a custom sign or nameplate for fabric panel wall systems. Attaches easily and securely to most panel wall systems with mounting clips (included).

ID No.	Color	Material	Size	Qty.	Unit	Price
2 AVT-75318	Clear	Acrylic	9 × 2	1	Each	<del>6.22</del>
3 AVT-75329	Clear	Acrylic	9 × 2	6	Pack	<del>31.39</del>

## PEOPLE POINTER™ A Perfect Sign Every Time

### C CUBICLE SIGN

Identify your cubicle with this customized sign. Patented design. Adjustable base. Sign is double-sided. Overall height of sign and base adjusts from 6½ to 8 inches.

ID No.	Color	Material	Size	Qty.	Unit	Price
4 AVT-75334	Black	Plastic	8½ × 2	1	Each	<del>19.95</del>

## Fellowes

### D MESH PARTITION ADDITIONS™ NAMEPLATE

Displays name, title or department name. Innovative ViperPin™ technology attaches to any tackable surface. Print text or graphics for custom display; free templates available on manufacturer's website. Clear cover. 100% recyclable.

ID No.	Color	W × D × H	Qty.	Unit	Price
5 FEL-7703201	Black	9¼" × ¾" × 3¼"	1	Each	<del>14.99</del>

### E PLASTIC PARTITION ADDITIONS™ NAMEPLATE

Display names, titles or departments on partition walls. 8 × 1½ viewable area displays text or graphics that you customize and print. 100% recyclable.

ID No.	Color	W × D × H	Qty.	Unit	Price
6 FEL-75906	Dark Graphite	9" × ¾" × 2½"	1	Each	<del>13.49</del>

\* Contains 96% post-consumer recycled content, 96% total recycled content.

## COMPLYRIGHT

### F LABOR LAW POSTER SERVICE

Service makes it easy to comply with mandatory federal and state labor law posting regulations. Once your service term begins, you will be shipped an initial set of federal and state or federal contractor posters. You will then receive one-year of free, automatic replacement posters whenever a mandatory posting requirement changes or a new posting is added.

ID No.	W × H	Qty.	Unit	Price
<b>Federal Contractor</b>				
7 COS-098435	4" × 7"	1	Each	<del>54.99</del>
<b>Federal English/State English</b>				
8 COS-098433	4" × 7"	1	Each	<del>87.99</del>
<b>Federal Bilingual/State English</b>				
9 COS-098434	4" × 7"	1	Each	<del>97.99</del>

## universal.

### G CALL BELL

Attention grabber. Emits a clean, clear tone. Nickel plated bell with black base. Great for reception counters and customer service areas.

ID No.	Dia.	Finish	Unit	Price
10 UNW-10000	3¾"	Brushed Nickel	Each	<del>5.99</del>

## DURABLE

THE STYLE OF SUCCESS

### H SHERPA® INFOBASE SIGN STAND

Takes your message from the printer to the public in a snap! Telescopic floor sign stand for 8½" × 11" inserts. Removable hard acrylic panel is open on three sides for easy loading. Tilt-adjustable panel can be viewed from either side. 40-60" height-adjustable pole posts sign at desired level. Stable round base.

ID No.	Color	Overall Height	Insert W × H	Material	Unit	Price
11 DBL-558957	Gray	Adjustable 40-60"	8½ × 11	Acrylic/Metal	Each	<del>162.95</del>

## quartet.

### I DESIGNER SIGN STAND

Standing nearly 5-feet tall, this durable 11" × 17" aluminum frame instantly turns signs, literature, fliers and printouts into customized displays. Ideal for high-traffic environments. Dual-function display panel rotates vertically or horizontally. Frame fits both 8½" × 11" and 11" × 17" inserts.

ID No.	Color	Overall Height	Insert W × H	Material	Unit	Price
12 QRT-7922	Silver	59"	8½ × 11; 11 × 17	Aluminum	Each	<del>373.63</del>

## NEWON

### J "OPEN" SIGN

Let customers know you are open for business. Uses high-intensity, energy efficient red and blue LEDs. Motion setting feature attracts attention. Economical, long-lasting design. Includes power connections and mounting chain. Manufacturer's limited three-year warranty.

ID No.	Color	Material	Message(s)	Size	Unit	Price
13 USS-5583	Black	Plastic	Open	13 × 21	Each	<del>130.65</del>

## HEADLINE<sup>®</sup>

BY SIGN

### K GLOW IN THE DARK SIGN

Design promotes high visibility from a distance. Made of durable, tear-resistant plastic. Graphics glow in the dark for added safety.

ID No.	Color	Material	Message(s)	Size	Unit	Price
14 USS-4792	Red	Durable Plastic	Exit	8 × 12	Each	<del>4.95</del>
15 USS-4793	Red	Durable Plastic	Fire Extinguisher	4 × 13	Each	<del>4.95</del>

## deflecto<sup>®</sup>

### L SUPERIOR IMAGE<sup>®</sup> WINDOW DISPLAY

Double-sided display easily mounts to glass, and non-porous doors and walls with suction cups (included). Inserts simply slide in and out. Clear plastic protects and keeps message visible. For horizontal or vertical display. Heat-resistant/UV protected for long life. Personalize and print signs from your own printer using Deflecto's free online SignCreator<sup>®</sup>.

ID No.	Color	Material	Insert W × H	Unit	Price
16 DEF-899102	Clear	Plastic	8½ × 11	Each	<del>31.19</del>

Prices subject to change without notice.  
Visit our website for the latest pricing and product information.

# Office Furnishings Step Stools/Ladders



## How To Choose A Ladder

**WEIGHT** Select ladder of proper duty rating to support combined weight of user and materials. Ladders are available with duty ratings of 200, 225 and 300 lbs.

**SAFETY** Make sure the ladder meets or exceeds ANSI and OSHA safety codes.

**WARNING:** Metal ladders conduct electricity. Do not use where contact may be made with live electrical circuits.



### A ROLLING STEP STOOL, CURVED DESIGN

Casters retract when stepped on. Antiskid bottom. Textured step surface. Manufacturer's limited one-year warranty.

ID No.	Color	Duty Rating	Working Height	Diameter	Unit	Price
1 RCP-252300BGE	Beige	350 lbs	13.5"	16"	Each	141.67
2 RCP-252300BK	Black	350 lbs	13.5"	16"	Each	141.67



### B COMMERCIAL STEP STOOL

Large 1 1/4" x 12 1/4" top platform step; steps have nonskid treads. Folds for easy storage. Durable, tubular steel frame forms handrail and knee brace. WARNING: Metal ladders conduct electricity. Do not use where contact may be made with live electrical circuits. Manufacturer's limited ten-year warranty.

ID No.	Color	Duty Rating	Working Height	Width	Unit	Price
<b>TWO-STEP—Opti-Bond™ Powder-Coated Finish.</b>						
3 CSC-11-829GGB *	Gray	300 lbs	21"	20.5"	Each	146.74
<b>THREE-STEP—Opti-Bond™ Powder-Coated Finish.</b>						
4 CSC-11-839GG0 *	Gray	300 lbs	31.5"	20.5"	Each	177.92

\* ANSI Type IA, Extra Heavy Duty Commercial; OSHA Compliant.

### C TWO-STEP FOLDING STEP STOOL

Steel step stool features strong metal steps with ribbed, slip-resistant treads. Continuous rear-leg support provides added stability. Durable Opti-Bond™ powder-coated finish resists scratches. Nonmarring, skid-resistant front legs and back glides. Convenient handle for easy carrying. Manufacturer's limited ten-year warranty.

ID No.	Color	Duty Rating	Working Height	Width	Unit	Price
5 CSC-11-135CLGG1 *	Cool Gray	200 lbs	28.13"	17.38"	Each	61.16

\* ANSI Type III, Light Duty Household; OSHA Compliant.

### D THREE-STEP BIG STEP FOLDING STEP STOOL

Steel step stool has large, heavy-duty injection molded polypropylene resin steps with ribbed, slip-resistant treads. Continuous rear leg support provides increased stability. Comfortable handgrip. Nonmarring leg tips keep floors clean. Folds flat for convenient storage and transport. Manufacturer's limited ten-year warranty.

ID No.	Color	Duty Rating	Working Height	Width	Unit	Price
6 CSC-11-408PBL1E *	Light Gray	200 lbs	45.63"	17.75"	Each	107.16

\* ANSI Type III, Light Duty Household; OSHA Compliant.



### E FIBERGLASS STEP LADDER

Commercial non-conductive fiberglass step ladder. The ProTop™ holds quarter/half/full gallon paint cans, has curved front for comfort, tool and drill slots and 2 x 4 or pipe holding slot. Slip-resistant rubber feet and pinch-resistant spreader braces provide safety and stability. Manufacturer's limited 90-day warranty.

ID No.	Color	Working Height	Spread Size	Duty Rating	Unit	Price
<b>Five-Step</b>						
7 DAD-FS40-06 *	Green/Black	8 ft	40.06"	225 lbs	Each	212.51
<b>Seven-Step</b>						
8 DAD-FS40-08 *	Green/Black	8 ft	51.88"	225 lbs	Each	288.50

\* ANSI Type II, Medium Duty Commercial; OSHA Compliant.



### F STOP-STEP® LADDER

Ideal for warehouses, storerooms and stocking areas. Rolls when pushed and stops when stepped on. Steps have nonslip treads. Scratch-resistant powder coating. WARNING: Metal ladders conduct electricity. Do not use where contact may be made with live electrical circuits. Manufacturer's limited ten-year warranty.

ID No.	Color	Working Height	Duty Rating	Unit	Price
<b>Four-Step—With left handrail.</b>					
9 CRA-1041L-19 *	Beige	66.25"	300 lbs	Each	857.00
<b>Four-Step—With right handrail.</b>					
10 CRA-1041R-19 *	Beige	66.25"	300 lbs	Each	857.00

\* ANSI Type IA, Extra Heavy Duty Industrial; OSHA Compliant.



**A 119-PIECE TOOL SET**

Tool set includes 30 sockets (SAE and metric), 3/8" drive ratchet, spark plug socket, 3" extension bars, wrenches, pliers, 39 bits with holder, 24 hex keys, hammer, torpedo level, tape measure and four screwdrivers. Manufacturer's lifetime warranty.

ID No.	Number of Pieces	Unit	Price
1 GNS-TK119	119	Kit	86.70

**STANLEY**

**B HOME AND OFFICE TOOL KIT**

Ultra-compact general repair tool kit for portable convenience. Water-resistant zippered case holds 12-ft. tape rule, 8" torpedo level, 7-oz. wood claw hammer, picture hanging fasteners, two screwdrivers (4" standard and #2 Phillips), 4" long nose pliers, and 6" slip joint pliers.

ID No.	Number of Pieces	Unit	Price
2 BOS-92-680	8	Kit	57.29

**boardwalk.**

**C EASY GRIP TAPE MEASURE**

Heavy-duty casing withstands constant use and rubberized grips for comfort and control. Measures both English and Metric units. Tape marks have additional bold highlights at each foot or 10 cm increment. Metal tip at beginning of tape can secure at corners for easy drag and measuring. Equipped with locking mechanism to hold tape at desired length. Metal pocket clip to hang from belts and convenient wrist strap when on the go. Manufacturer's limited one-year warranty.

ID No.	Blade W x L	Color	Unit	Price
3 BWK-TAPEM25	1" x 25 ft	Black; Yellow	Each	7.99



**D SHEFFIELD® EXTRAMARK™ TAPE MEASURE**

Tape measure features large, easy-to-read markings for quick and accurate measurement. Positive lock holds blade securely. Convenient belt/pocket clip. Ergonomic rubber grip handle.

ID No.	Blade W x L	Color	Unit	Price
4 GNS-58652	1" x 25 ft	Black/Red	Each	13.54



**E NYLON CABLE TIES**

Tamper-resistant tie holds securely without losing its grip. Won't stretch or slide so it stays in place. Tightens and locks as needed to secure cables, cords and other loose items. Strong and durable for convenience and peace of mind. Black ties are UV stabilized for longer outdoor use. Made of non-conductive nylon. UL listed.

ID No.	Finish	Size	Qty.	Unit	Price
5 TCO-22200	Natural	3/16" w x 8" l	1000	Pack	57.90
6 TCO-22300	Natural	3/16" w x 11" l	500	Pack	57.90



**F GIANT FOOT® DOORSTOP**

Impact resistant Sanoprene TRP will not crush.

ID No.	Color	W x D x H	Qty.	Unit	Price
7 MAS-00964	Brown	3 1/2" x 6 3/4" x 2"	1	Each	8.75

**G BIG FOOT® DOORSTOP**

No slip rubber compound with extra-wide footprint. Suitable for use in homes and offices.

ID No.	Color	W x D x H	Qty.	Unit	Price
8 MAS-00920	Brown	2 1/4" x 4 3/4" x 1 1/4"	1	Each	5.45
9 MAS-00941	Gray	2 1/4" x 4 3/4" x 1 1/4"	1	Each	5.45

**Value Pack**—Stock up and save!

10 MAS-00971	Brown	2 1/4" x 4 3/4" x 1 1/4"	2	Pack	9.95
11 MAS-00972	Gray	2 1/4" x 4 3/4" x 1 1/4"	2	Pack	9.95

A



B



C



D



E



F



G



# Office Furnishings Utility Carts



## A UTILITY CART WITH LOCKING DOORS

The all-plastic construction makes this wheel cart durable and easy to maintain. Like many Rubbermaid utility carts, this unit features easy to grip handles for simple maneuverability. A 200-pound weight limit makes it ideal for many applications. Lockable doors provide security when needed, while side and back panels on this rolling utility cart conceal contents. A sliding drawer easily stores smaller items. Four 4" Non-Marking Swivel Casters. Manufacturer's limited one-year warranty.

ID No.	Finish	W x D x H	Shpg. Wt.	Unit	Price
1 RCP-345700BLA	Black	33½" x 18½" x 37¾"	45 lbs.	Each	661.53

## B THREE-SHELF SERVICE CART WITH BRUSHED ALUMINUM UPRIGHTS

Ideal for office use. Shelves have one flat side for easy loading; lip on three sides. Easy to assemble. 3" Swivel Casters. Manufacturer's limited one-year warranty.

ID No.	Finish	W x D x H	Shpg. Wt.	Unit	Price
2 RCP-9T6571BG	Beige	16¼" x 31½" x 36"	36 lbs.	Each	370.52

## C THREE-SHELF SERVICE CART

Versatile; for audio/video, filing, food service. Shelves feature ¼" lip on three sides and one flat side for easy loading. Brushed aluminum uprights, dual molded handles. Four 4" Non-Marking Swivel Casters. Manufacturer's limited one-year warranty.

ID No.	Finish	W x D x H	Shpg. Wt.	Unit	Price
3 RCP-3424-88 BLA	Black	18½" x 33½" x 37¾"	30 lbs.	Each	428.72
4 RCP-342488PM	Platinum	18½" x 33½" x 37¾"	30 lbs.	Each	428.72



## D SCOOT™ THREE SHELF UTILITY CART

Built from pure steel, this cart features a unique hole pattern design and 3" over-sized casters (two locking). Accessible handle for easy maneuverability. Powder coat finish for durability. Rated up to 300 lbs. (100 lbs. per shelf). Manufacturer's limited lifetime warranty.

ID No.	Finish	W x D x H	Shpg. Wt.	Unit	Price
5 SAF-5339BL *	Black/Silver	31" x 18" x 38"	50 lbs.	Each	450.00

\* GREENGUARD Certified.

## E WIRE UTILITY CART

Transport and store materials safely and efficiently with wire utility carts. Each shelf holds up to 200 lbs. Shelves conveniently adjust in 1" increments. Rolls smoothly on four, 3" nylon casters. Plastic liners for each shelf help prevent contents from being damaged. Manufacturer's limited lifetime warranty.

ID No.	Finish	W x D x H	Shpg. Wt.	Unit	Price
<b>Three Shelf Cart</b>					
6 SAF-5338BL *	Black	43¾" x 19¼" x 40½"	37 lbs.	Each	256.00
<b>Two Shelf Cart</b>					
7 SAF-5337BL *	Black	43¾" x 19¼" x 40½"	29 lbs.	Each	212.00

\* GREENGUARD Certified.



## F MOBILE FILE CART

Keep paperwork handy when you need it and out of the way when you don't. Wheels glide with ease for mobility and lock for stability. Front-to-back and side-to-side filing. Four 2" Dual-Wheel Hooded Casters (2 Locking). Manufacturer's limited five-year warranty.

ID No.	Finish	W x D x H	Shpg. Wt.	Unit	Price
8 ALE-FM642212G *	Silver	22½" x 12½" x 25¼"	16 lbs.	Each	189.00

\* Meets or exceeds ANSI/BIFMA Standards.

## G THREE SHELF WIRE CART WITH LINERS

Easy to assemble and no tools required. Three adjustable shelves with pull handle. 500 lbs. total weight capacity. Manufacturer's limited five-year warranty.

ID No.	Finish	W x D x H	Shpg. Wt.	Unit	Price
<b>Four 4" Casters (two locking).</b>					
9 ALE-SW333018SR *	Silver	34½" x 18" x 40"	27 lbs.	Each	249.00
<b>Four 3" Casters (two locking).</b>					
10 ALE-SW322416SR *	Silver	28½" x 16" x 39"	24 lbs.	Each	161.00

\* Meets or exceeds ANSI/BIFMA Standards.

## H THREE-TIER WIRE CART WITH BASKET

Sturdy and solid wire cart for mobile shelving needs. Includes four casters (two locking). Black Anthracite finish for wet and dry usages. Shelves adjust in 1" increments. 500 lbs. total weight capacity. Four Locking Casters. Manufacturer's limited five-year warranty.

ID No.	Finish	W x D x H	Shpg. Wt.	Unit	Price
<b>Four 4" Casters—Two wire shelves, one wire basket, three shelf liners, four 35" poles and one pull handle.</b>					
11 ALE-SW543018BA *	Black Anthracite	34" x 18" x 40"	41 lbs.	Each	270.00
<b>Four 3" Casters—Two wire shelves, one wire basket, four poles and one pull handle.</b>					
12 ALE-SW342416BA *	Black Anthracite	28" x 16" x 39"	26 lbs.	Each	179.00

\* Meets or exceeds ANSI/BIFMA Standards.





Converts to a platform truck in seconds!



Folds down for compact storage.



## A HEAVY DUTY ADAPTABLE UTILITY CART

Provides superior versatility for tackling whatever task is at hand. Crafted of structural foam, this rolling service and utility cart can support up to 250 lb per shelf while reducing the need for time-consuming user modifications. Features a variety of integrated features including an ergonomic adjustable handle with four positions for maximum comfort, a flip-up shelf, a slotted rim for small tool storage, two snap-in hooks for wrapping extension cords and locking casters to keep the cart stable during use. Four Casters (2 Locking).

ID No.	Finish	W x D x H	Shpg. Wt.	Unit	Price
1 RCP-1997208	Black	25.2" x 51.5" x 36"	49 lbs.	Each	<del>449.68</del>
2 RCP-1997206	Black	17.8" x 46.2" x 36"	37 lbs.	Each	<del>398.68</del>

## B CONVERTIBLE UTILITY CART

Versatile, durable cart is able to perform a wide variety of tasks. This rolling utility cart features easy-to-clean smooth surfaces, swivel castors for easy mobility, and user-friendly easy-to-grip handles. Four 5" Swivel Casters (2 Rear Locking). Manufacturer's limited one-year warranty.

ID No.	Finish	W x D x H	Shpg. Wt.	Unit	Price
3 RCP-43000BK	Black	23 $\frac{3}{4}$ " x 45 $\frac{1}{4}$ " x 34 $\frac{3}{4}$ "	58 lbs.	Each	<del>976.40</del>

## C EXECUTIVE SERVICE CART

The cart brings the utmost in style, durability, and functionality to its users. This utility cart provides 20% more top-shelf capacity than previous Rubbermaid utility carts and accommodates two RCP bus boxes sold separately). The sleek, contemporary styling is ideal for front or back of house applications. The rolling utility cart has wrap-around end panels and solid base bumper. Smooth surface is easier to clean and maintain. This plastic utility cart offers simple assembly with a soft mallet; all-plastic construction with easy snap-and-lock assembly. Manufacturer's limited one-year warranty.

ID No.	Finish	W x D	Shpg. Wt.	Unit	Price
4 RCP-9T6800BK	Black	20 $\frac{1}{4}$ " x 38 $\frac{3}{4}$ "	38 lbs.	Each	<del>397.50</del>

## D FLAT SHELF UTILITY CART

Perfect for transporting materials, supplies, and heavy loads in almost any environment. Ergonomically-designed push handle provides optimum hand placement and push height, improving control and worker safety. Molded-in storage compartments, holsters, hooks, and notches for ideal storage. The rolling utility cart features molded-in customizable fittings. High-density structural resin construction. Easy-access bottom shelf. Best-in-class casters to meet the most demanding environments. Two 5" Swivel Non-Marking Casters.

ID No.	Finish	W x D x H	Shpg. Wt.	Unit	Price
5 RCP-452500BG	Beige	25 $\frac{1}{4}$ " x 44" x 38 $\frac{1}{2}$ "	38 lbs.	Each	<del>421.63</del>
6 RCP-452500BK	Black	25 $\frac{1}{4}$ " x 44" x 38 $\frac{1}{2}$ "	38 lbs.	Each	<del>421.63</del>
7 RCP-450500BG	Beige	19 $\frac{1}{4}$ " x 37 $\frac{3}{4}$ " x 33 $\frac{1}{2}$ "	31 lbs.	Each	<del>380.45</del>
8 RCP-450500BK	Black	19 $\frac{1}{4}$ " x 37 $\frac{3}{4}$ " x 33 $\frac{1}{2}$ "	27 lbs.	Each	<del>380.45</del>

## E HEAVY-DUTY UTILITY CART

Perfect for transporting materials, supplies, and heavy loads in almost any environment. Ergonomically-designed push handle provides optimum hand placement and push height, improving control and worker safety. Molded-in storage compartments, holsters, hooks, and notches for ideal storage. The rolling utility cart features molded-in customizable fittings. High-density structural resin construction. Easy-access bottom shelf. Best-in-class casters to meet the most demanding environments.

ID No.	Color	W x D x H	Capacity	Shpg. Wt.	Unit	Price
9 RCP-452088BG	Beige	25 $\frac{3}{4}$ " x 45 $\frac{1}{4}$ " x 32 $\frac{1}{2}$ "	500 lbs.	38 lbs.	Each	<del>403.14</del>
10 RCP-452088BK	Black	25 $\frac{3}{4}$ " x 45 $\frac{1}{4}$ " x 32 $\frac{1}{2}$ "	500 lbs.	41 lbs.	Each	<del>403.16</del>
11 RCP-450088BG	Beige	17 $\frac{1}{2}$ " x 38 $\frac{1}{2}$ " x 38 $\frac{3}{4}$ "	500 lbs.	42 lbs.	Each	<del>354.92</del>
12 RCP-450088BK	Black	17 $\frac{1}{2}$ " x 38 $\frac{1}{2}$ " x 38 $\frac{3}{4}$ "	500 lbs.	30 lbs.	Each	<del>354.99</del>

## F SERVICE/UTILITY CARTS

Quiet, lightweight and easy to maneuver cart. Two large trays hold items to be transported. 300 lb. capacity. Molded-in handle with handy storage compartments. 5" non-marking swivel casters. Four 5" Non-Marking Casters. Manufacturer's limited one-year warranty.

ID No.	Finish	W x D x H	Shpg. Wt.	Unit	Price
13 RCP-9T6700BLA	Black	24" x 40" x 31 $\frac{1}{4}$ "	43 lbs.	Each	<del>354.92</del>
14 RCP-9T6600BLA	Black	17" x 38" x 31"	31 lbs.	Each	<del>310.88</del>

Prices subject to change without notice.

Visit our website for the latest pricing and product information.

# Office Furnishings Vacuums



	Sanitaire®	Sanitaire®	Sanitaire®	HOVER® COMMERCIAL	Sanitaire®
<b>Model</b>	<b>A</b> FORCE™ QuietClean® Upright Vacuum SC5845B	<b>B</b> TRADITION™ Upright Vacuum SC887B	<b>C</b> TRADITION™ Upright Vacuum SC689A	<b>D</b> Task Vac™ Bagless Lightweight Upright	<b>E</b> TRADITION™ Upright Vacuum SC684F
<b>ID</b>	1	2	3	4	5
<b>No.</b>	EUR-SC5845B *	EUR-887D *	EUR-SC689 *	HVR-CH53010 *	EUR-SC684F *
<b>Unit</b>	Each	Each	Each	Each	Each
<b>Price</b>	490-32	514-15	267-79	309-63	315-97
<b>Motor</b>	10 amp	7 amp	5 amp	12 amp	7 amp
<b>Cleaning Path</b>	15"	12"	12"	14"	12"
<b>Shpg. Wt.</b>	24 lbs.	22 lbs.	20 lbs.	25 lbs.	18 lbs.
<b>Height Adjustment</b>	Seven Position	Yes	Six Position	Five Position	Six Position
<b>On Board Tools</b>	Yes	....	....	Yes	....
<b>Headlight</b>	....	....	....	....	....
<b>Furniture Guard</b>	Yes	Yes	Yes	....	Yes
<b>Filtration System</b>	Sealed HEPA	....	Standard	HEPA Media	Standard
<b>Cord Length</b>	40 ft	50 ft	30 ft	35 ft	50 ft
<b>Compliance Standards</b>	CRI Seal of Approval; LEED Applicable	CSA Certified; OSHA approved for commercial use; UL Listed	CSA Certified; OSHA Approved for commercial use; UL Listed	CRI Gold Certified; UL Listed	CSA Certified; OSHA Approved for commercial use; UL Approved
<b>Manufacturer's Warranty</b>	....	Manufacturer's limited two-year warranty.	....	Manufacturer's limited one-year warranty.	Manufacturer's limited two-year warranty for commercial use.
<b>Dust/Dirt Cup</b>	Yes	Yes	Yes	Yes	....
<b>ACCESSORIES</b>					
<b>ID</b>	....	....	....	6	....
<b>No.</b>	....	....	....	HVR-40140201	....
<b>Description</b>	....	....	....	Replacement Filter for Hush Vacuum	....
<b>Unit</b>	....	....	....	Each	....
<b>Price</b>	....	....	....	34-10	....
<p>* EUR-SC5845B—CRI Seal of Approval; LEED Applicable.                      EUR-887D, EUR-SC689, EUR-SC684F—CSA Certified; OSHA approved for commercial use; UL Listed.                      HVR-CH53010—CRI Gold Certified; UL Listed.</p>					



## JAGUAR PLASTICS. Commercial Can Liners

### A INDUSTRIAL STRENGTH COMMERCIAL CAN LINERS FLAT PACK

High-density polyethylene offers superior film strength; ideal for paper and non-sharp objects. Star seal bottom helps prevent leakage. Individually folded and dispensed.

ID No.	Capacity	W × H	Gauge	Color	Qty.	Unit	Price
1 JAG-H3340S	33 gal	33" × 40"	16 microns	Natural	200	Carton	<del>77.24</del>
2 JAG-H4048H	40 gal to 45 gal	40" × 48"	13 microns	Natural	200	Carton	<del>86.65</del>
3 JAG-H4048S	40 gal to 45 gal	40" × 48"	16 microns	Natural	200	Carton	<del>102.39</del>
4 JAG-H4348S	56 gal	43" × 48"	16 microns	Natural	200	Carton	<del>110.23</del>
5 JAG-H3860H	60 gal	38" × 60"	13 microns	Natural	200	Carton	<del>102.75</del>
6 JAG-H3860S	60 gal	38" × 60"	16 microns	Natural	100	Carton	<del>63.11</del>

### B INDUSTRIAL STRENGTH COMMERCIAL CORELESS ROLL CAN LINERS

Star seal bottom helps prevent leakage. High-density polyethylene offers superior film strength ideal for paper and nonsharp objects. Perforated for easy tear-off and dispensing convenience.

ID No.	Capacity	W × H	Gauge	Color	Qty.	Unit	Price
<b>8 Rolls of 25 Bags</b>							
7 JAG-RH3660H	55 gal	36" × 60"	13 microns	Natural	200	Carton	<del>93.50</del>
8 JAG-RH4348S	56 gal	43" × 48"	16 microns	Natural	200	Carton	<del>123.30</del>
9 JAG-RH3860H	60 gal	38" × 60"	13 microns	Natural	200	Carton	<del>108.43</del>
10 JAG-RH3860S	60 gal	38" × 60"	16 microns	Natural	200	Carton	<del>133.75</del>
<b>10 Rolls of 15 Bags</b>							
11 JAG-RH386022BLK	60 gal	38" × 60"	22 microns	Black	150	Carton	<del>113.79</del>
<b>10 Rolls of 25 Bags</b>							
12 JAG-RH3340S	33 gal	33" × 40"	16 microns	Natural	250	Carton	<del>97.73</del>
13 JAG-RH4048H	40 gal to 45 gal	40" × 48"	13 microns	Natural	250	Carton	<del>107.93</del>
14 JAG-RH4048S	40 gal to 45 gal	40" × 48"	16 microns	Natural	250	Carton	<del>134.70</del>
<b>20 Rolls of 25 Bags</b>							
15 JAG-RH3037S	20 gal to 30 gal	30" × 37"	16 microns	Natural	500	Carton	<del>162.81</del>
16 JAG-RH3340M	33 gal	33" × 40"	12 microns	Natural	500	Carton	<del>137.54</del>

### C INDUSTRIAL STRENGTH COMMERCIAL CAN LINERS

Can liner's star-sealed bottom helps prevent leakage. Made from high-quality blended resins for superior strength and puncture resistance. Bulk flat-pack box for easy storage and dispensing.

ID No.	Capacity	W × H	Gauge	Color	Qty.	Unit	Price
<b>40 Rolls of 50 Bags</b>							
17 JAG-RH171806	4 gal	17" × 18"	6 microns	Natural	2000	Carton	<del>66.51</del>

## boardwalk.

### D HIGH-DENSITY CAN LINERS

Made from 100% prime resin for strength and durability. Star seal bottom design provides even weight distribution and easy removal from a receptacle. Coreless perforated rolls are easy to use and easy to carry.

ID No.	Capacity	W × H	Gauge	Color	Qty.	Unit	Price
<b>6 Rolls of 25 Bags</b>							
18 BWK-404622BLK	40 gal to 45 gal	40" × 46"	19 microns	Black	150	Carton	<del>76.81</del>
19 BWK-404622	40 gal to 45 gal	40" × 46"	19 microns	Natural	150	Carton	<del>76.81</del>
20 BWK-434722BLK	56 gal	43" × 47"	19 microns	Black	150	Carton	<del>86.29</del>
21 BWK-434722	56 gal	43" × 47"	19 microns	Natural	150	Carton	<del>86.29</del>
22 BWK-385822	60 gal	38" × 58"	19 microns	Natural	150	Carton	<del>91.46</del>
<b>8 Rolls of 25 Bags</b>							
23 BWK-434717	56 gal	43" × 47"	14 microns	Natural	200	Carton	<del>84.50</del>
24 BWK-385814	60 gal	38" × 58"	11 microns	Natural	200	Carton	<del>68.49</del>
25 BWK-385817BLK	60 gal	38" × 58"	14 microns	Black	200	Carton	<del>64.72</del>
26 BWK-386016	60 gal	38" × 58"	14 microns	Natural	200	Carton	<del>73.72</del>
<b>10 Rolls of 25 Bags</b>							
27 BWK-334016	33 gal	33" × 38"	14 microns	Natural	250	Carton	<del>55.50</del>
28 BWK-404612	40 gal to 45 gal	40" × 46"	10 microns	Natural	250	Carton	<del>67.21</del>
29 BWK-404614	40 gal to 45 gal	40" × 46"	11 microns	Natural	250	Carton	<del>57.61</del>
30 BWK-404616	40 gal to 45 gal	40" × 46"	13 microns	Natural	250	Carton	<del>69.55</del>
<b>20 Rolls of 50 Bags</b>							
31 BWK-242306	8 gal to 10 gal	24" × 24"	6 microns	Natural	1000	Carton	<del>38.30</del>
32 BWK-243306	12 gal to 16 gal	24" × 33"	6 microns	Natural	1000	Carton	<del>57.40</del>
<b>40 Rolls of 50 Bags</b>							
33 BWK-202206	7 gal	20" × 22"	6 microns	Natural	2000	Carton	<del>87.22</del>



### E LINEAR LOW-DENSITY CAN LINERS

Metalloccene and LLDPE/LD resin blends improve bag strength and elasticity to resist punctures. Contents show to deter pilferage. Star-sealed bottom construction distributes weight more evenly and resists leaks. Coreless rolls for convenient dispensing.

ID No.	Capacity	W × H	Gauge	Color	Qty.	Unit	Price
<b>10 Rolls of 10 Bags</b>							
34 WBI-434722C	56 gal	43" × 47"	0.9 mil	Clear	100	Carton	<del>83.00</del>
35 WBI-385822C	55 gal to 60 gal	38" × 58"	0.9 mil	Clear	100	Carton	<del>92.97</del>
<b>10 Rolls of 25 Bags</b>							
36 WBI-303618C	30 gal	30" × 36"	0.71 mil	Clear	250	Carton	<del>101.04</del>
37 WBI-333916C	31 gal to 33 gal	33" × 39"	0.63 mil	Clear	250	Carton	<del>94.59</del>
38 WBI-404616C	40 gal to 45 gal	40" × 46"	0.63 mil	Clear	250	Carton	<del>146.95</del>
<b>20 Rolls of 25 Bags</b>							
39 WBI-242315C	7 gal to 10 gal	24" × 23"	0.6 mil	Clear	500	Carton	<del>70.01</del>
40 WBI-243115C	16 gal	24" × 33"	0.6 mil	Clear	500	Carton	<del>100.51</del>

Prices subject to change without notice.  
Visit our website for the latest pricing and product information.

# Office Furnishings Waste Can Liners



*classic*

## A LINEAR LOW-DENSITY CAN LINERS

Metalocene and LLDPE/LD resin blends improve bag strength and elasticity to resist punctures. Star bottom seal construction distributes weight more evenly and resists leaks. Coreless rolls for convenient dispensing.

ID No.	Capacity	W x H	Gauge	Color	Qty.	Unit	Price
<b>10 Rolls of 10 Bags</b>							
1	WBI-434722G	56 gal	43" x 47"	0.9 mil	Black	100 Carton	75.49
2	WBI-385822G	55 gal to 60 gal	38" x 58"	0.9 mil	Black	100 Carton	76.50
<b>10 Rolls of 25 Bags</b>							
3	WBI-303618B	30 gal	30" x 36"	0.71 mil	Black	250 Carton	109.62
4	WBI-333916B	31 gal to 33 gal	33" x 39"	0.63 mil	Black	250 Carton	86.13
5	WBI-404616B	40 gal to 45 gal	40" x 46"	0.63 mil	Black	250 Carton	145.02
<b>20 Rolls of 25 Bags</b>							
6	WBI-242315B	7 gal to 10 gal	24" x 23"	0.6 mil	Black	500 Carton	76.62
7	WBI-243115B	16 gal	24" x 33"	0.6 mil	Black	500 Carton	79.59

## PLATINUM PLUS

### B CAN LINERS

Strong resin blend is designed for toughest use. Superior puncture-resistant sidewall strength. Star-bottom seal construction distributes weight more evenly and resists leaks. Coreless rolls for convenient dispensing. New dispenser carton.

ID No.	Capacity	W x H	Gauge	Color	Qty.	Unit	Price
<b>5 Rolls of 10 Bags</b>							
8	WBI-PLA3350	31 gal to 33 gal	33" x 40"	1.35 mil	Gray	50 Carton	51.26
<b>10 Rolls of 10 Bags</b>							
9	WBI-PLA3770	30 gal	30" x 36"	1.35 mil	Gray	100 Carton	87.70
10	WBI-PLA4070	31 gal to 33 gal	33" x 40"	1.35 mil	Gray	100 Carton	100.01

## JAGUAR PLASTICS Commercial Can Liners

### C INDUSTRIAL STRENGTH LOW-DENSITY COMMERCIAL CAN LINERS

Linear low-density polyethylene provides industrial-strength puncture and tear resistance. Star-seal bottom helps prevent leaks. Individually folded for quick and easy dispensing.

ID No.	Capacity	W x H	Gauge	Color	Qty.	Unit	Price
11	JAG-L2423L	8 gal to 10 gal	24" x 23"	0.35 mil	Black	500 Carton	47.54
12	JAG-W2423X	8 gal to 10 gal	24" x 23"	0.5 mil	White	500 Carton	58.00
13	JAG-L2432L	12 gal to 16 gal	24" x 32"	0.35 mil	Black	500 Carton	66.44
14	JAG-W2432X	12 gal to 16 gal	24" x 32"	0.5 mil	White	500 Carton	77.49
15	JAG-L3036H	20 gal to 30 gal	30" x 36"	0.65 mil	Black	200 Carton	65.50
16	JAG-VW3036X	20 gal to 30 gal	30" x 36"	0.7 mil	White	200 Carton	65.31
17	JAG-W3036X	20 gal to 30 gal	30" x 36"	0.9 mil	White	100 Carton	41.77
18	JAG-L3339H	33 gal	33" x 39"	0.6 mil	Black	200 Carton	71.88
19	JAG-W3339X	33 gal	33" x 39"	0.9 mil	White	100 Carton	50.02
20	JAG-G3339G	33 gal	33" x 39"	1.3 mil	Gray	100 Carton	69.85
21	JAG-G3339HBL	33 gal	33" x 39"	1.7 mil	Black	150 Carton	161.75
22	JAG-L4046H	40 gal to 45 gal	40" x 46"	0.7 mil	Black	100 Carton	56.87
23	JAG-W4046X	40 gal to 45 gal	40" x 46"	0.9 mil	White	100 Carton	76.73
24	JAG-4046 GREY	40 gal to 45 gal	40" x 46"	1.1 mil	Gray	100 Carton	88.45
25	JAG-G4046G	40 gal to 45 gal	40" x 46"	1.3 mil	Gray	100 Carton	99.81
26	JAG-G4046HBL	40 gal to 45 gal	40" x 46"	1.7 mil	Black	100 Carton	154.21
27	JAG-W4347X	56 gal	43" x 47"	0.9 mil	White	100 Carton	78.40
28	JAG-G4347G	56 gal	43" x 47"	1.3 mil	Gray	100 Carton	121.99
29	JAG-G4347HBL	56 gal	43" x 47"	1.7 mil	Black	100 Carton	153.87
30	JAG-L3858H	60 gal	38" x 58"	0.7 mil	Black	100 Carton	71.94
31	JAG-VW3858X	60 gal	38" x 58"	0.7 mil	White	100 Carton	63.93
32	JAG-W3858X	60 gal	38" x 58"	0.9 mil	White	100 Carton	82.41
33	JAG-3858 GREY	60 gal	38" x 58"	1.1 mil	Gray	100 Carton	101.16
34	JAG-G3858G	60 gal	38" x 58"	1.3 mil	Gray	100 Carton	119.36
35	JAG-G3858HBL	60 gal	38" x 58"	1.7 mil	Black	100 Carton	174.34

### D HEALTH CARE TRASH CAN LINERS

High-visibility, bright-red medical waste can liners are designed specifically for biohazard materials. High-quality, blended resin provides excellent puncture and tear resistance. Individually folded for quick and easy dispensing. Biohazard warnings printed in English and Spanish. Meets DOT requirements.

ID No.	Capacity	W x H	Gauge	Color	Qty.	Unit	Price
36	JAG-IW2432R	12 gal to 16 gal	24" x 32"	1.3 mil	Red	250 Carton	117.37
37	JAG-IW3339R	33 gal	33" x 39"	1.3 mil	Red	150 Carton	118.30
38	JAG-IW4046R	40 gal to 45 gal	40" x 46"	1.3 mil	Red	100 Carton	117.29

\* Conforms to ASTM D1709 Standards; Conforms to ASTM D1922 Standards.

### E INDUSTRIAL DRUM LINERS, ROLLS

Industrial strength drum liners feature a star-seal bottom that helps prevent leakage. Low-density polyethylene provides excellent resistance to punctures and tearing. Cored rolls.

ID No.	Capacity	W x H	Gauge	Color	Qty.	Unit	Price
<b>1 Roll of 50 Bags</b>							
39	JAG-D38634BN	60 gal	38" x 63"	2.7 mil	Black	50 Carton	143.75
40	JAG-D38634CL	60 gal	38" x 63"	2.7 mil	Clear	50 Carton	142.78
41	JAG-D3865	60 gal	38" x 65"	2.5 mil	Clear	50 Carton	155.79
<b>1 Roll of 75 Bags</b>							
42	JAG-D38633CL	60 gal	38" x 63"	1.8 mil	Clear	75 Carton	143.75



### F LINEAR LOW DENSITY CAN LINERS WITH ACCUFIT® SIZING

Stronger can liners are constructed of prime-quality resin. AccuFit® sizing ensures that bags won't fall into can. Designed for most common sizes and applications.

ID No.	Capacity	W x H	Gauge	Color	Qty.	Unit	Price
<b>1 Box of 50 Bags</b>							
43	HER-H5645TKRC1	23 gal	28" x 45"	0.9 mil	Black	50 Box	33.13
44	HER-H5645TCRC1	23 gal	28" x 45"	0.9 mil	Clear	50 Box	33.11
45	HER-H6644TKRC1	32 gal	33" x 44"	0.9 mil	Black	50 Box	37.03
46	HER-H6644TCRC1	32 gal	33" x 44"	0.9 mil	Clear	50 Box	37.03
47	HER-H7450TKRC1	44 gal	37" x 50"	0.9 mil	Black	50 Box	30.89
48	HER-H7450TCRC1	44 gal	37" x 50"	0.9 mil	Clear	50 Box	30.89
49	HER-H8053TCRC1	55 gal	40" x 53"	0.9 mil	Clear	50 Box	34.68
50	HER-H8053PKRC1	55 gal	40" x 53"	1.3 mil	Black	50 Box	47.87



## boardwalk.

### A LOW-DENSITY WASTE CAN LINERS

Performance bottom star seal to prevent leakage. Made from high-quality raw materials, mineral reinforced to enhance strength and puncture-resistance. Use with heavy loads and/or sharp/abrasive materials. Coreless rolls.

ID No.	Capacity	W x H	Gauge	Color	Qty.	Unit	Price
<b>4 Rolls of 25 Bags</b>							
1	BWK-3036SH	20 gal to 30 gal	30" x 36"	0.95 mil	Gray	100 Carton	45-55
2	BWK-3339SEH	33 gal	33" x 39"	1.1 mil	Gray	100 Carton	62-93
3	BWK-4046H	40 gal to 45 gal	40" x 46"	0.6 mil	Black	100 Carton	50-39
4	BWK-4046EXH	40 gal to 45 gal	40" x 46"	0.6 mil	White	100 Carton	35-03
5	BWK-4046SH	40 gal to 45 gal	40" x 46"	0.95 mil	Gray	100 Carton	79-70
6	BWK-528	55 gal to 60 gal	38" x 58"	0.95 mil	Gray	100 Carton	78-84
7	BWK-4347H	56 gal	43" x 47"	0.6 mil	Black	100 Carton	54-05
8	BWK-4347EXH	56 gal	43" x 47"	0.6 mil	White	100 Carton	38-04
9	BWK-3858EXH	60 gal	38" x 58"	0.6 mil	White	100 Carton	41-11
10	BWK-3858H	60 gal	38" x 58"	0.65 mil	Black	100 Carton	58-87
<b>5 Rolls of 20 Bags</b>							
11	BWK-4347SEH	56 gal	43" x 47"	1.1 mil	Gray	100 Carton	98-80
12	BWK-3858SEH	60 gal	38" x 58"	1.1 mil	Gray	100 Carton	107-82
<b>8 Rolls of 25 Bags</b>							
13	BWK-3036EXH	20 gal to 30 gal	30" x 36"	0.6 mil	White	200 Carton	52-97
14	BWK-3339H	33 gal	33" x 39"	0.5 mil	Black	200 Carton	68-42
<b>10 Rolls of 50 Bags</b>							
15	BWK-2423L	8 gal to 10 gal	24" x 23"	0.35 mil	Black	500 Carton	28-12
16	BWK-2432L	12 gal to 16 gal	24" x 32"	0.35 mil	Black	500 Carton	54-50
<b>20 Rolls of 25 Bags</b>							
17	BWK-2423EXH	8 gal to 10 gal	24" x 23"	0.4 mil	White	500 Carton	36-59
18	BWK-2432EXH	12 gal to 16 gal	24" x 32"	0.4 mil	White	500 Carton	60-95
<b>20 Rolls of 50 Bags</b>							
19	BWK-1717L	4 gal	17" x 17"	0.35 mil	Black	1000 Carton	41-55

\* BWK-528—Contains 70% total recycled content.

### B LOW DENSITY REPRO CAN LINERS

Can liner with equivalent strength of 2.0 mil liner. Perforated roll for easy dispensing. Coreless rolls save space and material.

ID No.	Capacity	W x H	Gauge	Color	Qty.	Unit	Price
<b>4 Rolls of 25 Bags</b>							
20	BWK-534	31 gal to 33 gal	33" x 39"	1.4 mil	Clear	100 Carton	45-55
21	BWK-516	33 gal	33" x 39"	1.2 mil	Black	100 Carton	51-95
22	BWK-520	33 gal	33" x 39"	1.6 mil	Black	100 Carton	62-40
23	BWK-531	40 gal to 45 gal	40" x 46"	1.1 mil	Clear	100 Carton	48-95
24	BWK-517	40 gal to 45 gal	40" x 46"	1.2 mil	Black	100 Carton	65-09
25	BWK-535	40 gal to 45 gal	40" x 46"	1.4 mil	Clear	100 Carton	66-14
26	BWK-521	40 gal to 45 gal	40" x 46"	1.6 mil	Black	100 Carton	89-24
27	BWK-533	55 gal to 60 gal	38" x 58"	1.1 mil	Clear	100 Carton	57-95
28	BWK-537	55 gal to 60 gal	38" x 58"	1.4 mil	Clear	100 Carton	78-83
29	BWK-532	56 gal	43" x 47"	1.1 mil	Clear	100 Carton	64-41
30	BWK-518	56 gal	43" x 47"	1.2 mil	Black	100 Carton	76-15
31	BWK-536	56 gal	43" x 47"	1.4 mil	Clear	100 Carton	87-27
32	BWK-522	56 gal	43" x 47"	1.6 mil	Black	10 Carton	104-21
33	BWK-519	60 gal	38" x 58"	1.2 mil	Black	100 Carton	77-81
34	BWK-523	60 gal	38" x 58"	1.6 mil	Black	100 Carton	107-33
<b>10 Rolls of 10 Bags</b>							
35	BWK-530	31 gal to 33 gal	33" x 39"	1.1 mil	Clear	100 Carton	33-97
36	BWK-538	55 gal to 60 gal	38" x 58"	1.75 mil	Clear	100 Carton	95-55
37	BWK-526	60 gal	38" x 58"	2 mil	Black	100 Carton	141-60

\* BWK-530, BWK-538, BWK-534, BWK-531, BWK-535, BWK-533, BWK-537, BWK-532, BWK-536—Contains 75% pre-consumer recycled content; 75% total recycled content.  
BWK-516, BWK-520, BWK-517, BWK-521, BWK-518, BWK-522, BWK-519, BWK-523, BWK-526—Contains 50% total recycled content.



### JAGUAR PLASTICS Commercial Can Liners

### C REPRO LOW-DENSITY CAN LINERS

Thick, low-density polyethylene provides excellent puncture and tear resistance. Star-sealed bottom helps maximize total capacity while reducing the potential for leakage.

ID No.	Capacity	W x H	Gauge	Color	Qty.	Unit	Price
<b>Individually Folded</b>							
38	JAG-R3339HH	33 gal	33" x 39"	2 mil	Black	150 Carton	126-06
39	JAG-R4046HH	45 gal	40" x 46"	2 mil	Black	100 Carton	107-04
40	JAG-R4347H	56 gal	43" x 47"	1.5 mil	Black	100 Carton	88-08
41	JAG-R4347HH	56 gal	43" x 47"	2 mil	Black	100 Carton	120-99
<b>10 Rolls of 10 Bags</b>							
42	JAG-R4046H	45 gal	40" x 46"	1.5 mil	Black	100 Carton	88-25
43	JAG-R3858H	60 gal	38" x 58"	1.5 mil	Black	100 Carton	88-77
44	JAG-R3858HH	60 gal	38" x 58"	2 mil	Black	100 Carton	128-10

\* LEED Applicable. Contains a minimum of 70% total recycled content.

### HANDI-BAG

### D SUPER VALUE PACK

Convenient quantity for users with lower requirements. The ideal bag for home office use. Flap-tie closure.

ID No.	Capacity	W x H	Gauge	Color	Qty.	Unit	Price
<b>1 Box of 130 Bags</b>							
45	WBI-HAB6FW130	8 gal	22" x 24"	0.6 mil	White	130 Box	28-23
<b>1 Box of 100 Bags</b>							
46	WBI-HAB6FK100	13 gal	23.75" x 28"	0.6 mil	White	100 Box	28-86
<b>1 Roll of 60 Bags</b>							
47	WBI-HAB6FT60	30 gal	30" x 33"	0.65 mil	Black	60 Box	28-86
<b>1 Roll of 40 Bags</b>							
48	WBI-HAB6FTL40	33 gal	32.5" x 40"	0.65 mil	Black	40 Box	28-86

### E DRAWSTRING KITCHEN BAGS

Drawstring closure on bags keeps everything clean and free from trash. Linear low density resin for greater stretch and puncture resistance. Comes in a low count convenience pack.

ID No.	Capacity	W x H	Gauge	Color	Qty.	Unit	Price
<b>1 Roll of 50 Bags</b>							
49	WBI-HAB6DK50	13 gal	24" x 27.38"	0.6 mil	White	50 Box	28-86

\* With Drawstring.

### F SUPER VALUE PACK CONTRACTOR BAGS

Convenient quantity for users with lower requirements. Extra heavy duty contractor bag.

ID No.	Capacity	W x H	Gauge	Color	Qty.	Unit	Price
50	WBI-WEB1CTR50	42 gal	33" x 48"	2.5 mil	Black	50 Carton	86-47

Prices subject to change without notice.

Visit our website for the latest pricing and product information.

# Office Furnishings Waste Can Liners

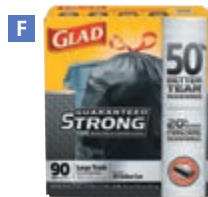

## A ULTRA STRONG TALL KITCHEN & TRASH BAGS

Strong and durable; easy to lift and carry. Convenient drawstring closure. Patented Arm & Hammer™ Odor Neutralizer eliminates garbage odors without adding any unwanted scents or fragrances; leaves your kitchen smelling the way you want.

ID No.	Capacity	W x H	Gauge	Color	Qty.	Unit	Price
1 PCT-E84570	13 gal	23.75" x 24.88"	0.9 mil	White	110	Box	<del>31.60</del>
2 PCT-E85274	30 gal	30" x 33"	1.1 mil	Black	74	Box	<del>31.60</del>

### Single-Roll Boxes - 3 Boxes of 110 Bags

3 PCT-E84570CT	13 gal	23.75" x 24.88"	0.9 mil	White	330	Carton	<del>94.80</del>
----------------	--------	-----------------	---------	-------	-----	--------	------------------

### 1 Carton of 222 Bags

4 PCT-E85274CT	30 gal	30" x 33"	1.1 mil	Black	222	Carton	<del>113.76</del>
----------------	--------	-----------	---------	-------	-----	--------	-------------------

## B ULTRA STRONG SCENTED TALL WHITE KITCHEN BAGS

Patented Arm & Hammer™ Odor Neutralizer eliminates garbage odors without adding any unwanted scents or fragrances; leaves your kitchen smelling the way you want. Convenient drawstring closure makes handling trash quick and easy.

ID No.	Scent	Capacity	W x H	Gauge	Qty.	Unit	Price
5 PCT-E84558	Clean Burst™	13 gal	23.75" x 24.88"	0.9 mil	80	Box	<del>27.40</del>
6 PCT-E84546	Citrus Twist™	13 gal	23.75" x 24.88"	0.9 mil	80	Box	<del>27.40</del>
7 PCT-E84561	Lavender & Sweet Vanilla™	13 gal	23.75" x 24.88"	0.9 mil	110	Box	<del>34.70</del>

### Single-Roll Boxes - 3 Boxes of 80 Bags

8 PCT-E84546CT	Citrus Twist™	13 gal	23.75" x 24.88"	0.9 mil	240	Carton	<del>82.40</del>
9 PCT-E84558CT	Clean Burst™	13 gal	24.75" x 24.88"	0.9 mil	240	Carton	<del>82.40</del>

### Single-Roll Boxes - 3 Boxes of 90 Bags

10 PCT-E84561CT	Lavender & Sweet Vanilla™	13 gal	23.75" x 24.88"	0.9 mil	330	Carton	<del>104.30</del>
-----------------	---------------------------	--------	-----------------	---------	-----	--------	-------------------

## C STRONG TALL KITCHEN DRAWSTRING BAGS

Strong and durable; easy to lift and carry. Convenient drawstring closure.

ID No.	Capacity	W x H	Gauge	Color	Qty.	Unit	Price
11 RFP-E84574	13 gal	34" x 48"	0.9 mil	White	90	Box	<del>31.00</del>

### Single-Roll Boxes - 3 Boxes of 90 Bags

12 RFP-E84574CT	13 gal	34" x 48"	0.9 mil	White	270	Carton	<del>94.20</del>
-----------------	--------	-----------	---------	-------	-----	--------	------------------



## D FORCEFLEXPLUS™ TALL KITCHEN DRAWSTRING TRASH BAGS

The unique diamond texture delivers real strength to make bags strong and prevent rips and tears. These drawstring bags stretch around objects to protect against punctures, leaks and trash messes.

ID No.	Capacity	W x H	Gauge	Color	Qty.	Unit	Price
13 CLO-70427	13 gal	23.75" x 24.88"	0.72 mil	White	100	Carton	<del>33.40</del>

## E FORCEFLEXPLUS™ DRAWSTRING LARGE TRASH BAGS

Designed with Durable Strength™ with a reinforced side seam carries the heavy loads without tearing the bag. Large capacity bags fit a 30 gallon can and stretch around trash with the ForceFlexPlus™ technology to prevent rips and tears. Built with advanced rip and tear protection, the LeakGuard™ Protection and RipGuard™ Protection can withstand even the toughest and messiest trash, so that what goes in, stays in. Strong reinforcing drawstring closure grips the can and ensures easy closing and lifting with one quick pull.

ID No.	Capacity	W x H	Gauge	Color	Qty.	Unit	Price
14 CLO-70358	30 gal	30" x 32"	1.05 mil	Black	70	Carton	<del>39.80</del>

## F DRAWSTRING LARGE TRASH BAGS

Guaranteed Strong for heavy-duty jobs, indoors or out with 50% better tear resistance, 20% more puncture resistance and a stronger drawstring versus the leading brand. The drawstring makes closing and carrying easy. You can count on Glad® bags to contain your messiest trash.

ID No.	Capacity	W x H	Gauge	Color	Qty.	Unit	Price
15 CLO-78952	30 gal	30" x 33"	1.05 mil	Black	90	Carton	<del>40.00</del>

## G ODORSHIELD® TALL KITCHEN DRAWSTRING BAGS

Provide strength plus odor control, to keep spaces smelling fresh and clean. Made with OdorShield technology and Febreze freshness for guaranteed 5 day odor control, based on lab test compared to unscented bags. The unique diamond pattern in these drawstring bags, stretches around objects to prevent rips and the reinforcing bands help add strength while reducing plastic waste, when compared to a leading branded bag. These trash can liners are reinforced at the top, middle and bottom and are made with thicker plastic for leak protection.

ID No.	Scent	Capacity	W x H	Gauge	Qty.	Unit	Price
16 CLO-78899BX *	Fresh Clean Scent	13 gal	24" x 27.38"	0.95 mil	80	Box	<del>30.80</del>
17 CLO-78901BX *	Hawaiian Aloha Scent	13 gal	24" x 27.38"	0.95 mil	80	Box	<del>30.80</del>

\* All Clorox products, including its subsidiaries are formulated to be in compliance with all local, state and federal regulations governing VOC emissions. This includes the categorical VOC limits of the California Air Resources Board (CARB), Ozone Transport Commission (OTC) and the United States Environmental Protection Agency (USEPA).

## H TALL KITCHEN DRAWSTRING TRASH BAGS

Drawstring bags are made strong and durable to help prevent trash disaster in the home and workplace. These kitchen garbage bags have reinforcing strength bands that make the trash bags stronger while using less plastic. They are reinforced at the top, middle and bottom. These drawstring bags are made with a unique diamond pattern that stretches around objects to prevent rips, reinforcing bands to add strength plus a thicker plastic for leak protection. The strong three-layer drawstring closure makes trash removal easy to lift, carry and toss away.

ID No.	Capacity	W x H	Gauge	Color	Qty.	Unit	Price
18 CLO-78526 *	13 gal	24" x 27.38"	0.95 mil	White	100	Box	<del>35.24</del>
<b>4 Boxes of 100 Bags</b>							
19 CLO-78526CT *	13 gal	24" x 27.38"	0.95 mil	White	400	Carton	<del>140.96</del>

\* California Air Resources Board (CARB) Compliant.



## A MARSHAL® CLASSIC CONTAINER

This Marshal® has arrived to help clean up the town. Practical good looks combine with fire safety in this durable plastic container. Push door conceals waste. Textured finish helps minimize appearance of surface scratches. Includes retainer hardware for securing and concealing can liners. For indoor use.

ID No.	Color	Capacity	Dia. × H	Unit	Price
1 RCP-816088BG *	Beige	15 gal	15¾" × 36½"	Each	<del>283.92</del>
2 RCP-816088BK *	Black	15 gal	15¾" × 36½"	Each	<del>283.92</del>
3 RCP-817088BG *	Beige	25 gal	18" × 42"	Each	<del>369.92</del>
4 RCP-817088BK *	Black	25 gal	18" × 42"	Each	<del>369.92</del>
5 RCP-8170-88 BRO *	Brown	25 gal	18" × 42"	Each	<del>369.92</del>

\* ADA Compliant; FM Approved.

## B FIBERGLASS WASTEBASKET

Fire-resistant trash cans feature a contemporary shape with a UL rating. Manufacturer's limited one-year warranty.

ID No.	Color	Capacity	W × D × H	Unit	Price
6 RCP-254100BG *	Beige	3.5 gal	11½" × 8¼" × 12¼"	Each	<del>51.39</del>
7 RCP-254300BG *	Beige	7 gal	14½" × 10½" × 15¼"	Each	<del>77.02</del>
8 RCP-254300BK *	Black	7 gal	14½" × 10½" × 15¼"	Each	<del>77.02</del>
9 RCP-254400BG *	Beige	10 gal	15" × 11¼" × 20"	Each	<del>101.39</del>

\* RCP-254100BG, RCP-254300BG—UL Classified; UL Listed; California State Fire Marshal Approved for Fire Safety (CSFM) containers.  
RCP-254300BK, RCP-254400BG—California State Fire Marshal Approved for Fire Safety (CSFM); UL Classified; UL Listed.

## C FIRE RESISTANT WASTEBASKET

Trash can features a contemporary shape with a UL rating.

ID No.	Color	Capacity	W × D × H	Unit	Price
10 RCP-2540 BEI *	Beige	1.75 gal	8¾" × 6¾" × 10½"	Each	<del>31.94</del>

\* California State Fire Marshal Approved for Fire Safety (CSFM); UL Classified; UL Listed.

## D DESKSIDE PLASTIC WASTEBASKET

Trash can is space-efficient and economical.

ID No.	Color	Capacity	W × D × H	Unit	Price
11 RCP-295500BG *	Beige	3.5 gal	11¾" × 8¼" × 12½"	Each	<del>40.38</del>
12 RCP-295500BK *	Black	3.5 gal	11¾" × 8¼" × 12½"	Each	<del>40.38</del>
13 RCP-295600BG	Beige	7 gal	14¾" × 10¼" × 15"	Each	<del>41.18</del>
14 RCP-295600BK *	Black	7 gal	14¾" × 10¼" × 15"	Each	<del>41.18</del>
15 RCP-295600GY	Gray	7 gal	14¾" × 10¼" × 15"	Each	<del>41.18</del>
16 RCP-295700BG	Beige	10.25 gal	15¼" × 11" × 19¾"	Each	<del>21.04</del>
17 RCP-295700BK *	Black	10.25 gal	15¼" × 11" × 19¾"	Each	<del>21.04</del>
18 RCP-295700GY	Gray	10.25 gal	15¼" × 11" × 19¾"	Each	<del>21.04</del>

\* RCP-295500BG—Optional lid not available.

RCP-295500BK—Contains a minimum of 30% post-consumer recycled content. Optional lid not available.

RCP-295600BK, RCP-295700BK—Contains a minimum of 30% post-consumer recycled content.

## E RECTANGULAR FREE-SWINGING LIDS

Fits Deskside Plastic Wastebaskets. Lids add a hygienic waste management solution, without reducing capacity. Manufacturer's limited one-year warranty.

ID No.	Color	For Model	Unit	Price
19 RCP-306600BG	Beige	RCP295600	Each	<del>24.04</del>
20 RCP-306600BK	Black	RCP295600	Each	<del>24.04</del>
21 RCP-306700BK	Black	RCP295700	Each	<del>25.14</del>



## F ONYX™ ROUND MESH WASTEBASKETS

Contemporary, practical mesh design is perfect for use in offices, meeting spaces and first impression areas. Features sturdy steel rims and welded construction. Mesh design permits air flow, which may help inhibit the growth of mold and odor. Powder coat finish for durability. Manufacturer's limited lifetime warranty.

No.	Color	Capacity	Dia. × H	Unit	Price
22 SAF-9716BL *	Black	3 qt	7½" × 9"	Each	<del>46.00</del>
23 SAF-9717BL *	Black	5 gal	13" × 14½"	Each	<del>39.00</del>
24 SAF-9718BL *	Black	9 gal	13½" × 19½"	Each	<del>44.00</del>

\* GREENGUARD Certified.



**Great Service**  
We can help you with  
selection & solutions.

Prices subject to change without notice.

Visit our website for the latest pricing and product information.

# Office Furnishings Waste Receptacles



## A EUROPEAN & METALLIC SERIES RECEPTACLE WITH DROP-IN DOME TOP

Waste stays put after it's placed through 5½" dia. disposal opening. Recessed side handles for easy emptying. Galvanized steel liner. Elegantly trimmed satin finish hides fingerprints, smudges and scratches. Manufacturer's limited one-year warranty. ♻️ ♻️ ♻️

ID No.	Color	Capacity	Dia. × H	Unit	Price
1 RCP-R32SSSSL ★	Satin Stainless	15 gal	15" × 32"	Each	404.34

★ ADA Compliant; California State Fire Marshal Approved for Fire Safety (CSFM); FM Approved; OSHA Compliant; UL Listed. Contains a minimum of 30% post-consumer recycled content.

## B EUROPEAN & METALLIC SERIES RECEPTACLE WITH DROP-IN TOP

5½" dia. opening for easy drop-in disposal. Lift-off design for easy emptying. Galvanized steel liner. Manufacturer's limited one-year warranty. ♻️ ♻️ ♻️

ID No.	Color	Capacity	Dia. × H	Unit	Price
2 RCP-CC16SSSSL ★	Satin Stainless	15 gal	15" × 28"	Each	512.27

★ ADA Compliant; California State Fire Marshal Approved for Fire Safety (CSFM); FM Approved; UL Listed. Contains a minimum of 30% post-consumer recycled content.

## C EUROPEAN & METALLIC SERIES WASTE RECEPTACLE WITH LARGE SIDE OPENING

Wide opening—11" × 5"—makes trash disposal easy. Lift-off design for easy emptying. Galvanized steel liner. Finish hides fingerprints, smudges and scratches. Manufacturer's limited one-year warranty. ♻️ ♻️ ♻️

ID No.	Color	Capacity	Dia. × H	Unit	Price
3 RCP-S016SSSSL ★	Satin Stainless	12 gal	15" × 28"	Each	538.52

★ ADA Compliant. Contains a minimum of 30% post-consumer recycled content.

## D EUROPEAN & METALLIC SERIES OPEN TOP HALF-ROUND RECEPTACLE

Trash can offers functional litter control in an elegant design. It has an open top with a vinyl trimmed disposal opening. Made of fire-safe steel. Its wall-hugging design is ideal for areas where looks are important and space is limited. Manufacturer's limited one-year warranty. ♻️ ♻️ ♻️

ID No.	Color	Capacity	W × D × H	Unit	Price
4 RCP-S01220B ★	Black/Chrome	12 gal	18" × 9" × 32"	Each	430.10
5 RCP-S012SSS ★	Satin Stainless	12 gal	18" × 9" × 32"	Each	708.37

★ ADA Compliant; FM Approved; UL Listed.

RCP-S01220B—Contains 30% total recycled content.

RCP-S012SSS—Contains a minimum of 30% post-consumer recycled content.

## E EUROPEAN & METALLIC SERIES HALF-ROUND WASTE RECEPTACLE

Wall-hugging design saves plenty of room. Features large 15" × 5" disposal side opening. Lift-off body for easy emptying of rigid plastic liner. Constructed of fire-safe steel. Manufacturer's limited one-year warranty. ♻️ ♻️ ♻️

ID No.	Color	Capacity	W × D × H	Unit	Price
6 RCP-S0820BPL ★	Black/Chrome	9 gal	18" × 9" × 32"	Each	359.25
7 RCP-S08SSSPL ★	Satin Stainless	9 gal	18" × 9" × 32"	Each	612.26

★ ADA Compliant; FM Approved; OSHA Compliant; UL Listed. Contains a minimum of 30% post-consumer recycled content.





Lids sold separately



## A RANGER® FIRE-SAFE CONTAINER

Need dependability in all kinds of weather? This container is for you. Durable structural foam construction is designed for outdoor use during all four seasons. Permanently attached hinged lid. Metal retainers keep can liners securely in place and out of sight. Manufacturer's limited one-year warranty.

ID No.	Color	Capacity	W × D × H	Unit	Price
1 RCP-9171-88BG *	Beige	45 gal	24½" × 28¾" × 41½"	Each	786.48
2 RCP-9173-88 BEI *	Beige	45 gal	24¾" × 24¾" × 41½"	Each	706.97
3 RCP-9173-88 BLA *	Black	45 gal	24¾" × 24¾" × 41½"	Each	706.97

### Four Openings

2 RCP-9173-88 BEI *	Beige	45 gal	24¾" × 24¾" × 41½"	Each	706.97
3 RCP-9173-88 BLA *	Black	45 gal	24¾" × 24¾" × 41½"	Each	706.97

### Two Swinging Doors

4 RCP-9171-88 BLA *	Black	45 gal	24¾" × 24¾" × 41½"	Each	786.48
---------------------	-------	--------	--------------------	------	--------

\* RCP-9171-88BG—ADA Compliant; FM Approved.  
RCP-9173-88 BEI, RCP-9173-88 BLA, RCP-9171-88 BLA—FM Approved.

## B UNTOUCHABLE® SQUARE WASTE RECEPTACLE

Featuring a sleek design, these containers are ideal for centrally located collection areas. Patent-pending cinch keeps your can-liner in place. Lids sold separately. Manufacturer's limited one-year warranty.

ID No.	Color	Capacity	W × D × H	Unit	Price
5 RCP-356988BG *	Beige	23 gal	15½" × 16½" × 31"	Each	117.38
6 RCP-356988BK *	Black	23 gal	15½" × 16½" × 31"	Each	117.38
7 RCP-356988GY *	Gray	23 gal	15½" × 16½" × 31"	Each	117.38
8 RCP-3959 BEI *	Beige	50 gal	19½" × 19½" × 34¼"	Each	262.78
9 RCP-3959 GRA *	Gray	50 gal	19½" × 19½" × 34¼"	Each	262.78

**Recycling Container**—Features the universal recycle-symbol imprint.

10 RCP-356973BE *	Blue	23 gal	16½" × 15½" × 31"	Each	117.38
-------------------	------	--------	-------------------	------	--------

\* RCP-356988BG, RCP-356988BK, RCP-356988GY, RCP-3959 BEI, RCP-3959 GRA—ADA Compliant.  
RCP-356973BE—Contains a minimum of 25% post-consumer recycled resin (PCR).

## C 35-GAL. RIGID WASTE LINER

Square garbage cans are space-efficient and economical. Manufacturer's limited one-year warranty.

ID No.	Color	Capacity	W × D × H	Unit	Price
11 RCP-395800BG *	Beige	35 gal	19½" × 19½" × 27¾"	Each	109.72

\* FM Approved.

## D UNTOUCHABLE® SWING TOP LID

Constructed of high-impact polystyrene and designed to be used with the Rubbermaid Commercial Untouchable trash can. Manufacturer's limited one-year warranty.

ID No.	Color	For Model	Unit	Price
12 RCP-268988BG	Beige	RCP356907; RCP356988	Each	51.95
13 RCP-268988BK	Black	RCP356907; RCP356988	Each	51.95

## E UNTOUCHABLE® SQUARE SWING TOP LID

Drop-and-swing design provides easy access for refuse disposal and then quickly returns to hide refuse from public view. Crack-resistant plastic. Controls waste, odors and smoking debris. Manufacturer's limited one-year warranty.

ID No.	Color	For Model	Unit	Price
14 RCP-2664 BEI	Beige	Rubbermaid® Commercial 3958, 3959	Each	104.30
15 RCP-2664GRAY *	Gray	Rubbermaid® Commercial 395800, 395900	Each	104.30

\* RCP-2664GRAY—ADA Compliant.

## boardwalk

### F SOFT-SIDED WASTEBASKET

Economy soft-sided wastebasket. Great for everyday use.

ID No.	Color	Capacity	W × D × H	Unit	Price
16 BWK-14QTWB BLA	Black	14 qt	11¾" × 8¾" × 12¼"	Each	8.40
17 BWK-28QTWB BLA	Black	28 qt	11" × 14¾" × 15"	Each	8.94
18 BWK-41QTWB BLA	Black	41 qt	16" × 11¾" × 20"	Each	16.68

Prices subject to change without notice.  
Visit our website for the latest pricing and product information.

# Office Furnishings Waste Receptacles/Recycling



Wastebasket sold separately

## A SLIM JIM® WITH VENTING CHANNELS

Designed to make trash removal easy. Venting channels take the strain out of liner removal, while the trash can's liner cinches to make removal faster. Manufacturer's limited one-year warranty.

ID No.	Color	Capacity	W x D x H	Unit	Price
1 RCP-354060BG	Beige	23 gal	22" x 11" x 30"	Each	94.26
2 RCP-354060BK	Black	23 gal	22" x 11" x 30"	Each	94.26
3 RCP-354060GY	Gray	23 gal	22" x 11" x 30"	Each	94.26

## B SLIM JIM® SWING LID

Top provides easy access for trash disposal, then swings back to hide refuse from view. Offers 61% more handsfree disposal area than earlier version. Manufacturer's limited one-year warranty. ♻️ ♻️ ♻️

ID No.	Color	For Model	Unit	Price
4 RCP-267360BK *	Black	RCP354100; RCP354000; RCP354007; RCP354060; RCP354075	Each	61.44
5 RCP-267360GY *	Gray	RCP354100; RCP354000; RCP354007; RCP354060; RCP354075	Each	61.44

\* Contains a minimum of 16% post-consumer recycled content.

## C HINGED LID FOR VENTED SLIM JIM®

Hinged lids for vented trash cans promote recycling and improve productivity. Manufacturer's limited one-year warranty.

ID No.	Color	For Model	Unit	Price
6 RCP-267400BK *	Black	Rubbermaid® Commercial 354060	Each	84.24

\* Conforms to FDA 5-501.113 Standards.

## D GLUTTON® RECYCLING STATION

Support your facility's recycling program, help reduce labor costs, and improve worker well-being with this all-in-one high-capacity and multifunctional recycling and waste unit. Includes restrictive opening tops, symbol label pack, and word label pack in three languages (English, French and Spanish). Hinged lid allows easy access during emptying. Manufacturer's limited one-year warranty. ♻️ ♻️ ♻️

ID No.	Color	Capacity	W x D x H	Unit	Price
<b>Two-Stream Glutton® Recycling Station</b> —One Glutton® container, two Slim Jim® receptacles, one lid frame, three restrictive-opening tops (circle, slot and square) and one label pack.					
7 RCP-1792339 *	Blue	46 gal	26½" x 23½" x 35½"	Each	723.48
<b>Four-Stream Glutton® Recycling Station</b> —Two Glutton® containers, four Slim Jim® 23-gallon containers, one hinged lid frame, eight restrictive-opening tops (4 circles, 2 paper slots, 1 square, 1 triangle) and one label pack.					
8 RCP-1792372 * ♻️ ♻️ ♻️	Blue	92 gal	53" x 24" x 35½"	Each	1,351.36

\* Contains a minimum of 30% post-consumer recycled content.

## E STACKING RECYCLE BIN

Made from linear low density polyethylene to withstand harsh weather conditions and prevent cracking, denting, or bowing. Manufacturer's limited one-year warranty. ♻️ ♻️ ♻️

ID No.	Color	Capacity	W x D x H	Unit	Price
9 RCP-571473BE *	Blue	14 gal	16" x 21" x 14¾"	Each	39.84
10 RCP-571873BE *	Blue	18 gal	16" x 26" x 14¾"	Each	51.30

\* Contains a minimum of 30% post-consumer recycled content.

## F WASTEBASKET RECYCLING SIDE BIN

Desk-side wastebasket makes recycling easy and convenient. Attaches inside or outside wastebasket and allows for separation of trash and recycling at each desk, without going to a central recycling location. Perfect for paper collection. Manufacturer's limited one-year warranty. ♻️ ♻️ ♻️

ID No.	Color	Capacity	W x D x H	Unit	Price
11 RCP-295073BE *	Blue	4.75 qt	7¼" x 10¾" x 11½"	Each	45.56

\* Contains a minimum of 30% post-consumer recycled content.

## G DESKSIDE RECYCLING CONTAINER

Recycle bin is an easy and effective way to increase waste management compliance. ♻️ ♻️ ♻️

ID No.	Color	Capacity	W x D x H	Unit	Price
12 RCP-295573BE *	Blue	13.625 qt	11½" x 8¼" x 12½"	Each	40.64
13 RCP-295673BE *	Blue	28.125 qt	14½" x 10¼" x 15"	Each	44.46
14 RCP-295773BE *	Blue	41.25 qt	11" x 15¼" x 19¼"	Each	21.86

\* Contains a minimum of 30% post-consumer recycled content.

## H SLIM JIM® RECYCLING STATION KIT

Offers an adaptable recycling solution to fit any commercial facility's recycling needs. Intuitive color coding, lid openings and labeling help you sort recyclables with ease. The three-stream station connects without the use of hardware for easy assembly. ♻️

ID No.	Color	Capacity	W x D x H	Unit	Price
<b>2-Stream—Landfill - Bottles/Cans</b>					
15 RCP-2007916	Gray; Yellow	46 gal	24" x 21½" x 40¼"	Each	296.96
16 RCP-2007914	Blue; Gray	46 gal	24" x 21½" x 40¼"	Each	296.96
17 RCP-2007915	Blue; Gray	46 gal	24" x 21½" x 40¼"	Each	296.96
<b>3-Stream—Landfill - Compost - Mixed Recycling</b>					
18 RCP-2007918	Blue; Gray; Green	69 gal	36" x 21½" x 40¼"	Each	439.24
19 RCP-2007917	Blue; Gray; Yellow	69 gal	36" x 21½" x 40¼"	Each	439.24
<b>4-Stream—Landfill - Paper - Plastic - Bottles/Cans</b>					
20 RCP-2007919	Blue; Gray; Red; Yellow	92 gal	48" x 21½" x 40¼"	Each	561.46



**B**



Extra-large wheels and molded-in foot tilt for easy maneuvering.

**C**



**D**



Lids sold separately



### **A** BRUTE® CADDY BAG

The trash can caddy fits 32- or 44-gallon BRUTE trash cans. Manufacturer's limited one-year warranty.

ID No.	Color	Size (W × H)	Unit	Price
1 RCP-264200YW	Yellow	20" × 20.5"	Each	73.72

### **B** BRUTE® ROLL-OUT HEAVY-DUTY CONTAINER

Offers a durable heavy-duty design with inset wheels and a molded-in catch bar.

ID No.	Color	Capacity	W × D × H	Unit	Price
2 RCP-9W21GY	Gray	65 gal	25½" × 32½" × 41½"	Each	195.40
3 RCP-9W22GY	Gray	95 gal	27¾" × 36" × 45½"	Each	243.11

### **C** SQUARE BRUTE® ROLLOUT CONTAINER

Your refuse collecting will really be rolling when you use this mobile unit. Built-in 8" rubber wheels. Attached hinged lid fits tightly, swings back and locks. Molded-in catch bar is compatible with automated lift systems. Manufacturer's limited one-year warranty.

ID No.	Color	Capacity	W × D × H	Unit	Price
4 RCP-9W27GY ★	Gray	50 gal	23¾" × 28½" × 36½"	Each	174.39
5 RCP-9W27 YEL ★	Yellow	50 gal	23¾" × 28½" × 36½"	Each	167.66

★ Contains a minimum of 30% post-consumer recycled content.

### **D** SQUARE BRUTE® CONTAINER

Trash can is designed with strength in mind from professional-grade, heavy-duty plastic with reinforced rims for added strength and molded grips for easy lifting. Manufacturer's limited one-year warranty.

ID No.	Color	Capacity	W × D × H	Unit	Price
6 RCP-352600GY	Gray	28 gal	21½" × 21½" × 22½"	Each	69.56
7 RCP-353600GY	Gray	40 gal	23¼" × 23¼" × 28¾"	Each	96.18

# Office Furnishings Waste Receptacles/Outdoor



Aggregate Panel Design

Recessed Panel Design

ADA Compliant



## A - B CANMELEON™ COLLECTION RECEPTACLES

Perfect for use in any first impression area. High-density polyethylene plastic will not chip or dent. UV inhibitors limit fading in sunlight. Adaptable for anchoring and weighting devices. Uses standard 32" x 44" trash bags and telescoping base hides bag.

### A CANMELEON™ AGGREGATE PANEL RECEPTACLES

Molded stone aggregate design with a recessed bottom. Perfect for any first impression area. High-density polyethylene plastic will not chip or dent. Manufacturer's limited lifetime warranty.

No.	Color	Capacity	W x D x H	Unit	Price
<b>Ash Urn with Side Openings</b> —9" sq. stainless steel urn built into lid. No sand required. Four 9½" x 4½" disposal openings.					
1	SAF-9470NC ★	Black	15 gal	13¾" x 13¾" x 32¾"	Each 575.00
<b>Ash Urn with Side Openings</b> —12" sq. stainless steel ash urn built into lid. No sand required. Four 13" x 6" disposal openings.					
2	SAF-9473NC ★	Black	38 gal	18¼" x 18¼" x 39¼"	Each 614.00
<b>Side Opening Style</b> —Four 13" x 6" disposal openings.					
3	SAF-9472NC ★	Black	38 gal	18¼" x 18¼" x 39¼"	Each 680.00

★ GREENGUARD Certified.

### B CANMELEON™ RECESSED PANEL RECEPTACLES

Recessed panel design for any first impression areas. High-density polyethylene plastic will not chip or dent. Panels feature fluted design with a recessed bottom.

No.	Color	Capacity	W x D x H	Unit	Price
<b>Ash Urn with Side Openings</b> —9" sq. stainless steel urn built into lid. No sand required. Four 9½" x 4½" disposal openings.					
4	SAF-9474BL ★	Black	15 gal	13¾" x 13¾" x 32¾"	Each 260.00
<b>Ash Urn with Side Openings</b> —12" sq. stainless steel ash urn built into lid. No sand required. Four 13" x 6" disposal openings.					
5	SAF-9477BL ★	Black	38 gal	18¼" x 18¼" x 39¼"	Each 469.00
<b>Side Opening Style</b> —Four 13" x 6" disposal openings.					
6	SAF-9476BL ★	Black	38 gal	18¼" x 18¼" x 39¼"	Each 344.00
<b>Top Opening Style</b> —9½" sq. disposal opening.					
7	SAF-9475BL ★	Black	38 gal	18¼" x 18¼" x 31½"	Each 249.00

★ GREENGUARD Certified.

## C EVOS™ SERIES STEEL WASTE CONTAINER

Attractive container helps manage waste and litter, indoors or out. Strong steel frame and decorative, galvanized steel panels are suitable in any first impression area. Four-sided opening makes it easy for pedestrians to drop their waste in passing. No assembly required and includes rigid plastic liner. Manufacturer's limited lifetime warranty.

No.	Color	Capacity	W x D x H	Unit	Price
8	SAF-9932BL ★	Black	15 gal	16" x 16" x 33¼"	Each 650.00
9	SAF-9934BL ★	Black	38 gal	21" x 21" x 41"	Each 873.00
<b>Ash Urn</b>					
10	SAF-9935BL ★	Black	38 gal	21" x 21" x 41"	Each 960.00

★ GREENGUARD Certified.

## D CANMELEON INDOOR/OUTDOOR PENTAGON RECEPTACLE

Recessed panels for any first impression areas. Plastic receptacle and telescoping lid are molded from high-density polyethylene. Built-in UV inhibitors limit fading in bright sunlight. Will not rust, chip or dent. Manufacturer's limited lifetime warranty.

No.	Color	Capacity	W x D x H	Unit	Price
11	SAF-9485BL ★	Black	30 gal	18" x 18½" x 28¾"	Each 217.00
12	SAF-9486BL ★	Black	45 gal	24" x 23" x 31½"	Each 277.00

★ GREENGUARD Certified.



## E STAINLESS STEEL TRASH RECEPTACLE

Attractive, durable receptacle is designed for indoor use (but may be used outdoors if placed under a protective canopy). Brushed stainless steel design is highlighted by a contemporary perforated pattern. Laser-cut, high-contrast "Trash" label and universal garbage symbol ensure "for-use" clarity. Flat lid features a fingerprint-proof black finish and an 8" diameter opening. Leak-proof LLDPE rigid plastic liner simplifies materials collection. Coated-steel security cable keeps lid and receptacle together, minimizing vandalism and theft. Wrap-around one-piece, gasket-style rubber foot protects floor surfaces. Manufacturer's limited one-year warranty.

ID No.	Color	Capacity	Dia. x H	Unit	Price
13	EXC-VCT-33PERF-S ★	Stainless Steel	33 gal	18" x 32"	Each 590.00

★ ADA Compliant.





The following tests were developed by the Business and Institutional Furniture Manufacturer's Association (BIFMA) and approved by the American National Standards Institute (ANSI). These performance tests determine the stamina of casegoods and seating in their day-to-day use on a single work shift over ten years. Concentrated load tests represent normal use conditions. Distributed loads represent excessive use conditions. All of our manufacturers recognize the value of building product to ANSI/BIFMA standards while only some manufacturers go to the added expense of having their products certified. Look for the ANSI/BIFMA symbol in this catalog to identify products that meet or exceed the ANSI/BIFMA standards.

## Casegood Testing Standards

### Durability Test

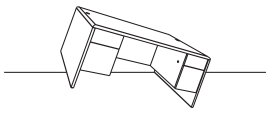

#### Drop Test

Each end is picked up and dropped to evaluate how well desk withstands impact on legs or base.

### Top Load Tests

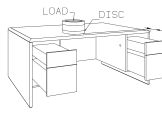

#### Concentrated Load Test

200 lbs. applied through 12" diameter at weakest point to ensure that no structural damage occurs from concentrated loads.

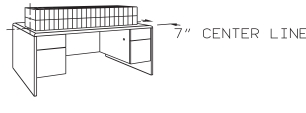

#### Distributed Load Test

1.5 lbs. per inch of perimeter applied to ensure that no personal injury results from distributed loads.



#### Ease Load Test

200-lb. bag lifted and dropped 10,000 times to test durability of desktop to endure cyclic loading.

### Drawer Tests

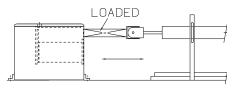

#### Cycle Test

Drawer is filled with .017-lb./cubic inch of volume and cycled 50,000 times to test support of common loads under normal operating conditions.

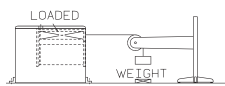

#### Outstop Test

Weighted load pulls drawer completely open 15,000 times to evaluate the effectiveness of outstops.

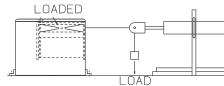

#### Pull Test

Measure of force needed to pull drawer open when filled with .017-lb./cubic inch of volume.

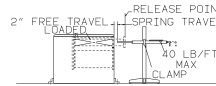

#### Rebound Test

Drawer is loaded, opened and forced closed 5 times to ensure drawer won't rebound over 1/2".

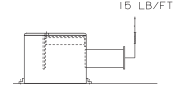

#### Retention Test

Unloaded open drawer has an outward force applied to ensure drawer won't accidentally disengage.

### Other Tests

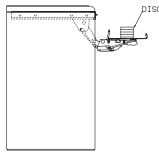

#### Adjustable Keyboard Surface Load Test

Tests keyboard drawer durability through 2,500 horizontal, 2,500 vertical and 2,500 swivel adjustments with a 10-lb. concentrated load.

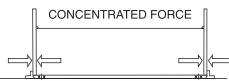

#### Leg Strength Test

100 lbs. of concentrated force inward and 50 lbs. of concentrated force outward on legs to test stability and support.

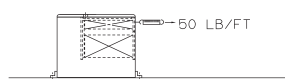

#### Lock Strength Test

50 lbs. of outward force applied to evaluate strength of locking mechanism.

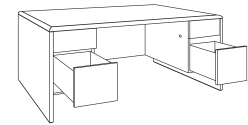

#### Stability Test

Largest drawer in each pedestal is opened and loaded to ensure desk won't tip when full.

## Seating Testing Standards

### Back Strength Tests



#### Swivel/Tilt Test

200 lbs. of concentrated force applied; 300 lbs. of distributed force applied.

#### Task/Guest Test

150 lbs. of concentrated force applied; 250 lbs. of distributed force applied.

### Back Durability Tests



#### Swivel/Tilt Test

Chair is fully reclined 120,000 times by 225 lbs. of force with a 225-lb. load on seat.

#### Task/Guest Test

Chair is tilted 120,000 times by 75 lbs. of force with a 225-lb. load on seat.

### Drop Weight Tests



#### Seating Impact Tests

125-lb. weight dropped onto seat 100,000 times.

#### 6" Drop Test

A 225-lb. concentrated load dropped 6" onto seat then a 300-lb. distributed load dropped 6" onto seat.

### Base Tests

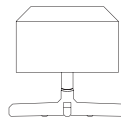

#### Base Tests

2,500 lbs. of concentrated force applied on base then 2,500 lbs. of distributed force applied on base for one minute each load.

### Stability Tests



#### Front Stability Tests

135 lbs. centered 2.4" from front edge of seat. Chair must be able to take 4.5 lbs. of horizontal force without tipping over.



#### Back Stability Tests

No less than 20 lbs. of pressure should be required to tip the chair back with 173 lbs. on seat.

### Caster Tests

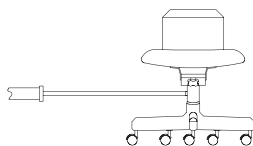

#### Caster Durability Test

Rolled along a 30" distance 100,000 times with a 250-lb. load.

### Armrest Strength Tests

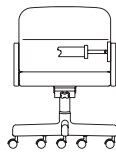

#### Outward Force Arm Test

A load force is applied outward on the arm; then 150 lbs. of distributed force is applied.

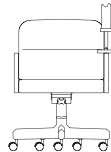

#### Downward Force Arm Test

A load force is pulled downward on the arm; then 300 lbs. of distributed force is applied.

### Footring Tests

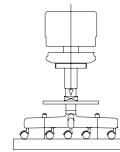

#### Footring Durability Test

200 lbs. of weight applied along a 4" length of footring 50,000 times.

### Swivel Tests

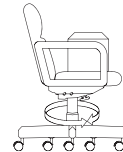

#### Swivel Cycle Test

Base is rotated 120,000 times with 225 lbs. on seat.

# Third-Party Certifications Guide



**ANSI/BIFMA Certification** ANSI/BIFMA certified furniture meets high standards for indoor air quality as well as safety and ergonomics in order to minimize health hazards and make injury less likely. Specific performance tests were developed by the Business and Institutional Furniture Manufacturer's Association (BIFMA) and approved by the American National Standards Institute (ANSI). These tests determine the stamina of casegoods and seating in their day-to-day use on a single work shift over ten years under both normal-use and excessive-use conditions.



The BIFMA Sustainability Standard

**BIFMA level™ Sustainability Certification level™** is the multi-attribute sustainability standard and third-party certification program for furniture products in the built environment. Furniture is evaluated for sustainability across four elements: a company's social actions, energy usage, material selection and human and ecosystem health impacts. The level™ brand identifies that a product has been examined and evaluated by an independent third-party certifier, and has earned a numeric marking of 1, 2, or 3 which indicates what threshold of certification it has achieved.

**level™ "requirements"** A product must first meet six mandatory prerequisites across the four elements and then accumulate points within each element, including product-related points, to determine its level. For more information, go to: [www.levelcertified.org](http://www.levelcertified.org)

### To achieve level™ 1:

- conform with all six prerequisites
- accumulate between 32 and 44 total points; at least 5 of the total points must be "product" related points for level™ 1 certification

### To achieve level™ 2:

- conform with all six prerequisites
- accumulate between 45 and 62 total points; at least 11 of the total points must be "product" related points for level™ 2 certification

### achieve level™ 3:

- conform with all six prerequisites
- accumulate between 63 and 90 total points; at least 18 of these total points must be "product" related points for level™ 3 certification

**California Flammability Standards Bulletin CA 116** Specifies requirements, test procedure and apparatus for testing the flame retardance of upholstered furniture. Measures the cigarette ignition resistance of an actual item of upholstered furniture.

**Bulletin CA 117** Specifies requirements, test procedures and apparatus for testing the flame retardance of resilient filling materials used in upholstered furniture. Measures flammability using both open flame and lighted cigarettes as the ignition sources. All upholstery components are tested.

**Bulletin CA 133** Specifies the flammability test procedure for seating furniture used in public occupancies such as jails, prisons, nursing homes, healthcare facilities, public auditoriums and hotels. It tests completed items of upholstered furniture and measures the type of ignition that may be typical of arson or incendiary fires or common accidental fires in public buildings.



**CARB Compliant** In January 2009, the California Air Resources Board (CARB), a department of the California Environmental Protection Agency, implemented limits for formaldehyde emitted from composite wood panels. The California regulation governs the formaldehyde in both raw composite wood panels and finished products sold or used in California. Both imported and domestic products are regulated and must be third-party certified and clearly labeled to indicate they meet California's requirements.

### Composite Panel Associates EPP Downstream Program

Products carrying the EPP Downstream logo are manufactured by a company that has demonstrated its environmental commitment by purchasing at least 50% CPA EPP certified composite wood products.



**ETL Listed** The ETL Listed Mark (Electrical Testing Lab) is proof of product compliance (electrical, gas and oil-fired) to North American safety standards. Products that bear the ETL Listed Mark have met the minimum requirements of widely accepted product safety standards as determined through the independent testing of Intertek, a Nationally Recognized Testing Laboratory (NRTL).



**GREENGUARD® Indoor Air Quality Certified** Identifies goods with low chemical and particle emissions for use indoors, primarily building materials, interior furnishings, furniture, cleaning and maintenance products, electronic equipment and personal care products. The GREENGUARD® Environmental Institute governs the integrity of the certification process.



**GREENGUARD® Children & Schools™ Indoor Air Quality Certified®** Identifies low-emitting interior building materials, furnishings and finish systems used in educational, office and other sensitive environments. All GREENGUARD® Children & Schools™ products have been tested for their chemical emissions performance according to CA 01350. The GREENGUARD Environmental Institute governs the integrity of the certification process.

**LEED-CI (LEED for Commercial Interiors)** LEED (Leadership in Energy and Environmental Design) for Commercial Interiors is a certification program developed by the U.S. Green Building Council that addresses the specifics of tenant spaces primarily in office, retail and institutional buildings. It gives the power to make sustainable choices to tenants and designers, who do not always have control over whole building operations. The green benchmark for the tenant improvement market, LEED for Commercial Interiors establishes high-performance green building criteria for use by both developers and tenants creating interiors that are healthy, productive places to work, are less costly to operate and maintain and have a reduced environmental footprint.



**NFSI (National Floor Safety Institute)** NFSI product certification is intended to provide product manufacturers the means to have their products independently evaluated for wet slip resistance. For a product to achieve NFSI certification status, it must pass both phases of a most comprehensive evaluation process including laboratory testing and field testing where a product is installed and utilized for a minimum of 30 days.



**NSF International** NSF International, an independent, not-for-profit organization, helps protect consumers by auditing and certifying as safe: food, water and other consumer products. NSF is a World Health Organization Collaborating Centre for Food and Water Safety and Indoor Environments and an American National Standards Institute (ANSI) accredited standards developer.



**SCS Indoor Advantage™** Certified conformance with Business and Institutional Furniture Manufacturer's Association (BIFMA) Standard for Low-Emitting Office Furniture Systems and Seating (ANSI/BIFMA X7.1) and LEED-CI criteria for the U.S. Green Building Council's Leadership in Energy and Environmental Design criteria EQ4.5 (furniture and seating).



**SCS Indoor Advantage Gold™** Certified additional conformance with California 01350 Special Environmental Requirements and Collaborative for High Performance Schools (CHPS). In order for a product to qualify for the Indoor Advantage Gold certification, modeled concentrations for individual VOCs (volatile organic compounds) in classrooms and offices must not exceed one-half of the defined CREL (chronic reference exposure levels) threshold. CRELs have been developed for 80 chemical substances. Given that other (uncertified) products and materials in the building may be sources of the same chemicals, the conservative standard set for Indoor Advantage Gold certification is intended to ensure that individual occupants' overall exposure to any one of these chemicals does not exceed the CREL.



**Intertek Green Leaf** Products have been independently tested and found to conform to multiple existing environmental regulations, such as RoHS (which restricts the use of hazardous substances in electrical and electronic goods), REACH (which regulates chemicals and their safe use) and Eco Design (considers impact on the environment throughout the life cycle of energy related products).



**UL Listed** Indicates that a product has been tested and certified as safe by Underwriters Laboratories Inc., an independent nonprofit organization that has developed more than 800 standards for safety. UL's web site is at <http://www.ul.com>. Information about UL standards can be found at [ul.com/global/eng/pages/solutions/standards/](http://ul.com/global/eng/pages/solutions/standards/)

**Adjustable Glides:** 1" to 2" leveling devices for stabilizing storage, chairs or panels. Also known as "height adjusters."

**Anti-Rebound:** The feature that ensures that a drawer will stay closed and not spontaneously recoil or roll out from the pedestal opening when the drawer is closed with normal force.

**Apron (on a desk):** The recessed desktop area that allows a visitor to sit in close.

**Articulating Keyboard:** Height-adjustable design swivels, tilts and rotates in order to facilitate the correct ergonomic position for arms, wrists and hands when typing. Retracts under the desk when not in use.

**Ball Bearing Slide:** A drawer device containing a number of metal or plastic balls that rotate for smooth opening and closing.

**Base Cap:** A solid cap that fits over a prong of the metal understructure base on a panel system.

**Base Cover:** The metal or extruded plastic part that covers the electrical power distribution system at the bottom of a panel system's workstation configuration.

**Book-Matched Veneers:** Sequential veneer sheets, folded to open like the pages of a book and bonded to a substrate board that produces a mirrored image. Common lay-up for most plain-sliced veneers.

**Box Drawers:** Small drawers, generally 6" in height, mainly in desks and pedestals.

**Bridge Worksurface:** Attaches between a desk and a credenza to form a U-shaped configuration.

**Cantilever:** Vertical slotted channels that accept the brackets to hang worksurfaces and storage pieces from systems furniture.

**Carbon Footprint:** A measure of the carbon emissions that are emitted over the full life cycle of a product or service and usually expressed as grams of carbon dioxide.

**Casegoods:** Refers to furniture made of hard materials, such as wood, metal, glass or plastic relating to desks, credenzas, bookcases, computer furniture and lateral files.

**Caster Sleeve:** A metal receptacle into which the casters are inserted.

**Catalyzed Lacquer:** A modified nitrocellulose-based coating with a catalyst added for enhanced performance and decreased curing time.

**Center Drawer (Pencil Drawer):** The drawer mounted beneath a worksurface.

**C-Legs:** An upright furniture support leg in the shape of the letter "C."

**Core (Sub-Core):** Interior material used to construct veneer panels (i.e., particleboard).

**Core-Removable Lock:** Designed with a removable cylinder that can be interchanged as needed allowing users to access all furniture with a single key.

**Credenza:** A storage unit, generally 18" to 24" deep, used with desks in private offices.

**Defeat Mechanism:** The mechanism that helps prevent the accidental tipping of a file.

**Desk—Bow Front:** A desk shell in which the surface bows outward away from the user.

**Desk—Double Pedestal:** A worksurface with pedestals at both ends of the unit.

**Desk—Table Desk:** Versatile furniture component that functions as a table and/or desk depending on user's needs.

**Dovetail:** A flaring joint between two pieces of wood, forming an interlocking tight fit.

**Drawer Dividers:** A partition in a box drawer that separates or divides the front portion from the back portion.

**Elevation:** A line drawing providing more spatial perception of a furniture layout.

**End Panels:** Slab end-supports commonly found on either side of a desk worksurface.

**Ergonomics:** The study of equipment design to reduce operator fatigue and discomfort. A person's relationship and interaction within work environments.

**Executive Chair:** A high-back or padded chair designed for senior decision-makers.

**Face Veneer:** The most visible surface veneer.

**Fiberboard:** A composition board consisting of fine thread-like fibers of wood bonded together with synthetic resins.

**File Drawer:** A drawer that is generally 12" to 13" in height and deep enough to support hanging file folders.

**Flipper Door:** The front door of an overhead storage unit, common in systems or office plans.

**Follower Block (in a file drawer):** Interior drawer panel keeps file folders and other materials upright and toward the front of the drawer.

**Footprint:** The working square footage required to support a particular function; either a workstation or group of workstations.

**Full-Height Pedestals:** Pedestals that extend from the worksurface to the floor.

**Fully Assembled:** Product shipped completely built rather than in parts or as flat stock.

**Ganging:** The method of joining individual seating elements into one unit. Specifically refers to ganging chairs or ganging tables. Often seen in lounge areas.

**Graining:** The process of printing a natural woodgrain pattern onto another surface that may or may not be wood product.

**Green:** A term used in reference to environmentally conscious initiatives, such as recycling or using environmentally sustainable, compostable, reusable or biodegradable and/or energy efficient content in the manufacture of a product.

**Grommet:** A covering of a cut-out that helps drop wires and cords under a worksurface for wire management.

**Guest Chair:** Often referred to as a Side Chair, this is a chair used by those who visit an office for the purpose of a meeting or conference.

**Hardwood:** Designates lumber produced from broad-leafed or deciduous trees in contrast to softwoods from evergreen or coniferous trees.

**High Pressure Laminate (HPL):** Also known as plastic laminate. Produced by fusing together multiple layers of kraft paper saturated with phenolic resin, with a layer of melamine saturated decorative paper, resulting in higher impact resistance than most other laminates.

**Hutch:** Storage component with cabinets and/or shelves that sits above a credenza or desk.

**Independent Seat and Back:** On a chair, seat and back flex independently for automatic comfort.

**Inlay:** Wood or other material set into corresponding carved out recesses, often producing a pattern.

**Interlock Mechanism:** A device that couples two or more drawers together to prevent simultaneous opening, averting injuries due to cabinet tipping.

**Junction Box:** An electrical outlet device or communications port box on an office wall generally requiring access for cord placement and plug-ins.

**KD:** Shipped Knocked Down or assembly required.

**L-Unit:** Consists of a front desk piece with a connecting “return” extending on either the “right” or “left” side, normally dependent on columns and entry door positioning.

**Laminate:** A product made by fusing thin layers of coated paper to an interior substrate.

**Lateral File:** A file cabinet where the file drawers are wide, as opposed to deep, allowing complete access to all files at once.

**Layout: (Space Plan)** A plan created by an interior designer or architect showing locations of tenant improvement and space utilization by the tenant.

**Leather:** Animal skin or hide that is tanned to preserve an otherwise perishable skin and protect it from water damage or bacterial decay. Various tanning methods give leather its unique character and quality. The tanning process lubricates the skin with oil to make it as pliable as possible.

**Leather — Bonded:** Material made of varying degrees of genuine leather combined with other substances to give the appearance of leather, but at reduced cost.

**Leather — Dyed:** Three processes are used to dye leather: aniline, semi-aniline and pigment (i.e., opaque color). The aniline process is used on top-of-the-line leather furniture in natural or full-grain leather. For skins with somewhat uneven color, a semi-aniline process is used that combines aniline dyeing and a pigment solution to make the colors more opaque. Pigment is used on the most heavily marked skins to completely cover them with opaque color.

**Leather — Full-Grain:** The thin, outer layer of a hide. Often the finest, most delicate, best quality and sophisticated in design. Aniline finishes are generally used to preserve full-grain leather.

**Leather — Natural:** A leather which has a distinctive smooth and supple feel, and a slightly shaded color due to the application of two-tone aniline or semi-aniline.

**Leather — Pigment:** A more durable leather capable of withstanding higher wear and tear. Made by a mid-priced process using more opaque pigments of semi-aniline dyeing.

**Leathermate:** Combination leather/vinyl that is a low-cost alternative to full leather upholstery. Typically used in low contact areas of a chair.

**Legal Size:** Sized for 8½ × 14 documents.

**Letter Size:** Sized for 8½ × 11 documents.

**Leveling Glides:** Support device for leveling or stabilizing furniture on uneven flooring.

**Louvers:** Slats that admit air and light; generally for ventilation or cooling.

**Low Pressure Laminate (Melamine or TFM — Thermally Fused Melamine):** Results when melamine paper is thermally bonded to particleboard or MDF panels. Offers less impact resistance than HPL.

**Lumbar:** The lower section of your back between the thoracic vertebrae and sacrum.

**Management Chair:** A mid-back chair designed for the person who spends a lot of time seated at a desk. Usually a chair with a 5-prong base fitted with casters.

**Mechanism:** The part of a chair that connects the seat assembly to the base and allows adjustments such as tilt, swivel, seat height, etc., to allow a user optimum comfort and productivity.

**Medium Density Fiberboard (MDF):** A composite wood product similar to particleboard and made out of wood waste fibers glued together with resin, heat, and pressure.

**Melamine:** A misused term often thought of as a type of laminate. Actually, it is a component layer found in laminate composites.

**Mesh Seat:** Seating products that have backs and/or seat cushion support derived from a porous, posture-fitting material.

**Mitered:** A joinery technique where two solid angled, beveled wood pieces are glued together at the corner.

**Modesty Panel (Floating, Formal, Full-Length, Full-Height, Open):** A vertical sheet of material on the front of a desk covering the frame, providing privacy and reinforcement. Partial or ¾ modesty panels end approximately 8 inches above the floor. Full modesty panels extend completely to the floor.

**Modular Furniture:** Groups of freestanding tables, storage pieces and privacy pieces combined to give the appearance of a panel system but offering user-friendly reconfigurability.

**Molding:** A decorative plane or curved strip giving ornamentation or finishing.

**Nesting:** Describes pieces of matching furniture in descending sizes that fit inside of each other for the purpose of stacking.

**Overhang:** A desk’s front area that overhangs the body or panels, normally 6" to 12" that allows guests to move closer in.

**Panel Systems Furniture:** Modular furniture consisting of various height panels dividing space and creating privacy in general office areas. Configured with worksurfaces and storage pieces.

**Panels:** Modular furniture sections used to define the limits of a workstation. Panels do not extend from floor to ceiling.

**Particleboard:** A higher quality board composed of distinct wood particles bonded together with a synthetic resin or other glues to form basic flakeboards or higher-quality fiberboards.

**Partition:** Inside floor-to-ceiling structures not otherwise meeting the criteria of walls. Partitions are movable or removable.

**Pedestals:** Storage components which consist of drawers in various configurations under a worksurface area.

**Peninsula:** A rounded-end top used in offices and/or workstations to accommodate meeting space. Also called a pork chop.

**Plywood:** Wood sheets glued together in three or more laminations.

**Pocket Door:** Storage doors that recess into the interior cabinet shell.

**Polyethylene:** The most extensively produced polymer, a lightweight thermoplastic; used especially in packaging and insulation.



**Polyurethane:** Various polymers used in flexible and rigid foams, elastomers and resins.

**Post-Consumer Waste (PCW):**

Product that contains recycled material from products that have already been used by the consumer and then collected for recycling.

**Posting Shelf:** Pullout shelf used to sort and manage documents at the file.

**Raceways:** Tubes or channels designed to hold, guide and protect electrical wires.

**Racking:** The swaying that occurs when opening and closing the drawers of a file cabinet. Commercial file cabinets have features such as drawer suspension and leveling glides which prevent racking.

**Reconstituted Veneer (Re-Cuts):** Thin layers of wood glued together as a block, cut sideways and stained to imitate real wood. Offers particularly stable appearance and pattern consistency.

**Recycled (also Recovered) Material:**

Material that would have otherwise been disposed of as waste or used for energy recovery, but has instead been collected and recovered (reclaimed) as a material input thus avoiding the use of new primary materials.

**Repeat:** (Textile Patterns) The length and width measurement of a reappearing design or imprint on a fabric.

**Retrofit:** The act of improving an existing product with a newly introduced feature or attachment.

**Return (V, Bridge, Corner Desk, Desk Return):** A piece of furniture with a flat work surface that attaches to a desk to create an “L” configuration.

**Reuse:** Recovering value from a discarded resource without reprocessing or remanufacture.

**Sealants:** Finishing topcoat applied to an object by spray or wipe.

**Seat Suspension:** A system that supports the upper part of the seat assembly.

**Shared Space:** Two or more workers who share a single workstation and work tools.

**Shell:** Generally associated with modular office furniture, the desk shell is the sides (end panels), front (modesty panel) and top (work surface) of the desk.

**Sled Base:** On a chair, a tubular design approach to a chair’s base structure offered in either an arm/leg loop or platform rocker version.

**Slipmatched Veneer:** The laying out of veneer sheets by sliding each successive one across the next resulting in a repetitive grain pattern across a panel.

**Solid Woods:** Wood panel or edge piece having minimal 5-mm thickness.

**Spin Lift:** On a chair, mechanical height adjustment operated by spinning a chair counter-clockwise to raise and clockwise to lower.

**Spring-Activated Follower Block:** A mechanism to keep files upright when file drawer is partially full.

**Square Footage:** Length times the width of a room, space, floorplate or fabric product.

**Stained Wood:** Wood with the natural color modified to some degree—to make it more even and to imitate other wood essences.

**Star Base:** On a chair, the base to which the casters are attached, having five “arms” and forming the shape of a star.

**Suspended Pedestals:** Pedestals that are hung from a worksurface and only extend three-quarter depth to the floor. Also known as “¾ pedestals.”

**Suspension:** The system that is used to support the drawer and facilitate its movement in and out of the pedestal, normally three-quarter or full suspensions.

**Sustainability:** A characteristic of a process or state that can be maintained at a certain level indefinitely. The term, in its environmental usage, refers to the potential longevity of vital human ecological support systems, such as the planet’s climatic system, systems of agriculture, industry, forestry, fisheries and the systems on which they depend.

**Swatch:** A fabric sample used for determining finish and color compatibilities.

**Task Chair:** A chair designed to support individuals who perform task-intensive functions, set on a 5-prong centered base.

**Teflon:** Brand name of the topical fabric treatments to help repel stains and liquid.

**Thermally Fused Melamine (TFM):**

Results when melamine paper is thermally bonded to particleboard or MDF panels. Offers less impact resistance than HPL.

**Tongue & Groove:** A joint made by a tongue on one end of a board fitting into a corresponding groove on another edge.

**U-Shape:** Assembled desk, return and credenza storage that forms a U layout.

**UV Finish:** A color or wood finish that is light-baked onto a surface rather than rubbed on and absorbed into wood.

**Vein Line:** A design element, often called a “reveal,” which produces a visual demarcation of the individual pieces of the desk.

**Veneer:** Thin sheet of wood, sliced from a log, that is bonded to a panel’s interior substrate.

**Veneer Flip:** The tonal differences in color due to differing light reflections that occur when two wood surfaces adjoin at a right angle.

**Veneer Furniture:** Furniture made using thin sheets of wood glued onto a substrate that produces “show wood” quality product.

**Veneer Reconstituted (Re-Cuts):** Thin layers of wood glued together as a block, cut sideways and stained to imitate real wood. Offers particularly stable appearance and pattern consistency.

**Vertical File:** Filing units composed of drawers stacked vertically that store records from front to back rather than from side to side.

**Waterfall Design:** A softened, downward shape of a seat-front behind the back of the user’s legs that prevents nerve pressure, thereby increasing circulation.

**Whitewood:** Unfinished wood state.

**Wire Management:** The desktop grommet hole and channels used below the surface to manage cables efficiently.

**Woodgrain Furniture: (Faux Wood)** Exterior portions of furniture creating the impression of natural wood essence.

**Workstation:** A space where work is accomplished (inner office, open office area).

**Worksurface:** The top writing/storage surface areas of a workstation or office.

# ICON INDEX



Indicates a product that must be shipped freight.



Indicates a product that requires assembly.

**new**

Identifies items added since the last edition of this catalog.



Products made with at least 10% total recycled content.



Because there is no universally accepted standard to designate products as environmentally preferable, we have adopted the green leaf symbol to highlight products that have one or more of the following attributes: reduced VOCs, compostable, biodegradable, contains recycled content, or other environmental attributes that make this product less harmful to the environment or humans, when compared to its traditional counterparts. Many of the products marked with the green leaf symbol have been endorsed by third-party certifying organizations, and where applicable, the certifying body's logo appears next to the product's name. Please note that we have not independently verified the environmental attributes

*\*These environmental attributes refer to the products themselves and not the processes for manufacturing and transporting the products.*



Identifies a special order product which requires additional lead time.



Identifies items that cannot be returned.



Indicates the maximum weight a chair can support.



Meets or exceeds ANSI/BIFMA standards for safety and durability.



level™, the BIFMA e3 sustainability standard, was developed in response to the increasing demand for proof that manufacturers are living up to their environmental claims. level™ certification is based on four sustainability attributes: Materials, Energy and Atmosphere, Human and Ecosystem Health, and Social Responsibility.



Products composed in whole, or in significant part, of renewable, biological sources (including plant, animal and marine materials) or forestry materials. Certification is based on a product's biobased (new carbon) content only, as measured by ASTM D6866 test standards.



A business that is not less than 51% owned by one or more women; or in the case of a publicly owned business, not less than 51% of the stock must be owned by one or more women, and whose management and daily operations are controlled by one or more women.



Number indicates hours that item remains fireproof.



Products that meet the recovered material content ranges specified by the EPA through the Comprehensive Procurement Guideline (CPG).



Identifies goods with low chemical and particle emissions for use indoors, primarily building materials, interior furnishings, furniture, cleaning and personal care products and electronics.



Identifies low-emitting interior building materials, furnishings and finish systems used in educational, office and other sensitive environments. All GREENGUARD® Children & Schools™ products have been tested for their chemical emissions performance according to CA 01350.



Products have been independently tested and found to conform to multiple existing environmental regulations, such as RoHS (which restricts the use of hazardous substances in electrical and electronic goods), REACH (which regulates chemicals and their safe use) and Eco Design (considers impact on the environment throughout the life cycle of energy related products).



A renewable plant-based Biopolymer which is a USDA Certified Biobased material.



Conformance with Business and Institutional Furniture Manufacturer's Association (BIFMA) Standard for Low-Emitting Office Furniture Systems and Seating (ANSI/BIFMA X7.1) and LEED-CI criteria for the US Green Building Council's Leadership in Energy and Environmental Design criteria EQ4.5 (furniture and seating).



Additional conformance with California 01350 Special Environmental Requirements and Collaborative for High Performance Schools (CHPS).



Indicates products with a built-in antimicrobial agent which resists the growth of bacteria, mold and mildew that can cause stains, odors and product deterioration.



Products certified as safe for food preparation, consumption and storage by NSF International.



Meets Underwriters Laboratory safety requirements.



Meets ANSI and OSHA standards for step ladder safety.



Certified slip-resistant by the National Floor Safety Institute. For more information see [www.nfsi.org](http://www.nfsi.org).

- 3M**  
Boards ..... 247  
Brooms ..... 261  
Monitor Stands ..... 332
- A**
- ACCO®**  
Magnetic Clips ..... 242
- ACCUFFIT®**  
Trash Bags ..... 342
- Adhesives & Glues**  
Mounting Products ..... 275–276
- ADVANTUS®**  
Back Supports, Chair ..... 164  
Boards ..... 238  
Convertible Carts ..... 298  
Display Rails ..... 248  
File Carts ..... 179  
File Totes ..... 325–326  
Nameplates ..... 335  
Wall Panel Hooks ..... 244
- Alarms, Smoke/Carbon Monoxide** ..... 286
- ALBA**  
Coat Hangers ..... 271  
Coat Hooks ..... 274  
Coat Racks ..... 271–273  
Literature Racks & Displays ..... 307–308  
Umbrella Stands ..... 272
- ALERA®**  
Anti-Fatigue Mats ..... 43, 55, 294  
Back Supports, Chair ..... 163–164  
Benches ..... 75  
Bookcases ..... 15, 184–185  
Carts, Chair/Table ..... 152, 214, 217  
Carts, File ..... 180  
Carts, Mail ..... 197, 311  
Carts, Media ..... 306  
Carts, Service ..... 197, 263–264, 299  
Carts, Utility ..... 338  
Chair Arms ..... 126, 129  
Chair Casters ..... 155  
Chair Mats ..... 158  
Chairs ..... 72–73, 75–77, 81, 83–85, 89–91, 98–103, 109–110, 120, 123, 125–126, 132, 137, 140, 146, 149, 152–154, 214, 217  
Credenzas ..... 14–15, 36  
Desk Bridges ..... 14  
Desk Drawers ..... 15  
Desk Returns ..... 14–15  
Desks ..... 14–15, 37  
Fans ..... 282–283  
File Cabinets ..... 14–15, 24, 169, 175–177  
File Carts ..... 67  
Footrests ..... 84, 98, 143, 162  
Garment Hooks ..... 274  
Garment Racks ..... 197, 271  
Heaters ..... 300–301  
Hutches ..... 14–15  
Keyboard Shelves ..... 15  
Lamps ..... 15, 302–303  
Lock Core Kits ..... 15, 24  
Machine Stands ..... 65, 331  
Monitor Arms ..... 49  
Ottomans ..... 73, 77  
Privacy Panels ..... 68  
Reception Room Furniture ..... 72, 75–77  
Refrigerators ..... 329  
Seat Cushions, Chair ..... 163  
Seat Cushions, File Cabinet ..... 24, 176  
Sofas ..... 72  
Stools ..... 43, 53, 100, 102, 109, 125–126, 129–130, 141–142  
Storage Cabinets ..... 14, 24, 189  
Table Bases ..... 220  
Table Tops ..... 220  
Tables ..... 15, 38–39, 72–73, 202–203, 210, 214, 216–217, 222  
Wardrobe Cabinets ..... 15  
Wire Shelving & Accessories ..... 194–197  
Workstation Privacy Panels ..... 15  
Workstations ..... 42–43, 63
- ALLSOP®**  
Monitor Risers/Stands ..... 333
- APC®**  
UPS Backup Systems ..... 327
- Arms, Chair** ..... 111, 124, 126–132, 139
- Arms, Monitor** ..... 41–43, 49
- Art & Drafting**  
Files ..... 226–227  
Tables ..... 226
- ARTISTIC®**  
Desk Pads ..... 281
- AT-A-GLANCE®**  
Dry Erase Surfaces ..... 243
- AVANTI**  
Refrigerators ..... 329
- Award**  
Certificate Frames ..... 296–297
- B**
- Back Supports**  
Chair ..... 163–164
- Backup Power Systems** ..... 327
- Bags**  
Trash ..... 341–344
- Balance Boards** ..... 56, 143
- BANKERS BOX®**  
File Storage Boxes ..... 225
- BARRICKS**  
Tables ..... 212
- BELKIN®**  
Surge Protectors ..... 328
- Benches, Reception Room** ..... 75
- Bins**  
Mesh Shelving Unit ..... 182  
Wire Shelving ..... 196
- BIONAIRE™**  
Fans ..... 282
- Blood Clean-Up Kits** ..... 289
- Board Supplies**  
Planning Accessories ..... 242
- Boards**  
Bulletin ..... 244–249, 260  
Cork ..... 239, 241, 245–249, 260  
Cubicle/Personal ..... 241, 245, 249–250  
Dry Erase ..... 68, 228–241, 243, 249–256  
Dry Erase/Bulletin ..... 239, 241, 249–250  
Easel ..... 253–259  
Enclosed Bulletin ..... 260  
Fabric ..... 244–246, 249, 260  
Glass ..... 229–231, 237, 240  
Magnetic Dry Erase ..... 204, 228–235, 237–241, 249–252, 254–255  
Planning ..... 238–241  
Presentation ..... 204, 231  
Wet Erase ..... 252, 258
- BOARDWALK®**  
Blood Clean-Up Kits ..... 289  
Brooms ..... 261–262  
Disinfectant Wipes ..... 267  
Facial Tissue ..... 321  
Hand Soaps ..... 268  
Paper Towel Dispensers ..... 318, 320  
Paper Towels ..... 317, 319, 322  
Soap Dispensers ..... 268  
Toilet Seat Covers ..... 312  
Toilet Tissue ..... 312, 314  
Toilet Tissue Dispensers ..... 315  
Trash Bags ..... 341, 343  
Wastebaskets ..... 347  
Wipers ..... 324
- Bookcases**  
Laminate ..... 184–187  
Metal ..... 188
- BOUNTY®**  
Towel Rolls ..... 322
- Boxes**  
File ..... 325–326
- Breakroom**  
Appliances ..... 329  
Beverage & Service Carts ..... 265  
Facial Tissue ..... 321  
Paper Towels ..... 322–323  
Bridges, Desk ..... 10, 14–15, 19, 21, 32, 34
- BRIGHT AIR®**  
Air Fresheners & Dispensers ..... 268
- Brochure Racks** ..... 308
- Broom Handles/Heads** ..... 261
- Brooms** ..... 261–262
- Bulletin Bars** ..... 252
- BUSH®**  
Bookcases ..... 19  
Credenzas ..... 19  
Desks ..... 18–19, 22–23  
Drawers, Desk ..... 22  
File Cabinets ..... 18–19  
Hutches ..... 18–19  
Keyboard Shelves ..... 22  
Modular Workstations ..... 23
- C-LINE®**  
Cubicle Accessories ..... 252  
Dry Erase Sheets ..... 252  
Dry Erase Supplies ..... 251
- Cabinets**  
Display ..... 21  
Janitorial ..... 191  
Storage ..... 6, 8, 10, 14, 19, 21, 24, 30, 169, 189–191, 193  
Wardrobe ..... 15, 17
- Cable Management**  
Cord Managers ..... 39
- Calendars**  
Dry Erase ..... 249
- Call Bells** ..... 335
- Cards**  
Magnetic Data ..... 232
- Carrels, Study** ..... 66
- Carts**  
Book ..... 263, 299  
Chair ..... 147–148, 152–153
- Chair/Table ..... 217  
Computer ..... 61, 63  
File ..... 67, 179–182, 326  
Mail ..... 197, 264, 299, 311, 338  
Media ..... 306  
Refreshment ..... 265  
Service ..... 197, 263–264, 311, 338–339  
Utility ..... 263–264, 299, 311, 338–339
- Casters**  
Chair ..... 155  
Table ..... 38, 205  
Wire Shelving ..... 196
- Certificate Frames** ..... 296–297
- Chair**  
Arms ..... 124, 126–132, 139  
Carts ..... 147–148, 152–153, 217  
Casters ..... 155  
Mats ..... 156–160  
Seat Cushions ..... 163–164
- Chairs**  
24/7 ..... 123, 132  
Ball ..... 50  
Big & Tall ..... 87–88, 105, 137–140, 149, 152  
Café/Bistro ..... 96, 142  
Extended Height ..... 131, 133  
Folding ..... 153–154, 217  
Guest ..... 72–73, 75–77, 81–83, 85, 91–95, 100, 104, 115, 117, 119, 122  
Indoor/Outdoor ..... 221  
Leather ..... 22, 81–95, 113, 115, 119–121, 124–126, 137–139  
Mesh ..... 20, 96–118, 124–126, 132, 138, 144–146, 150, 208  
Nesting ..... 144, 147, 208  
Office ..... 20, 22, 81–127, 132, 137–140  
Reception Room ..... 72–73, 75–77  
Sit-To-Stand ..... 51–53  
Stacking ..... 76, 92–93, 96, 100, 104, 115, 117, 140, 142, 145–152, 214  
Stools ..... 50–53, 96, 100, 102, 106, 109, 115, 118, 122, 124–131, 133–136, 141–142, 150–151  
Task ..... 97, 99, 104–108, 111–112, 116, 118, 123–127, 132
- Chests, Fire-Resistant** ..... 173
- CHIX®**  
Wipers ..... 324
- CLASSIC**  
Trash Bags ..... 341–342
- Cleaners**  
Bathroom ..... 266  
Disinfectants ..... 266  
Furniture Polish ..... 267  
Wood ..... 267
- Cleaning & Sanitation**  
Cleaning Products ..... 266–267  
Cleaning Tools & Supplies ..... 261–262, 340  
Hand Soaps ..... 268  
Restroom Supplies ..... 312  
Toilet Tissue Dispensers ..... 315  
Towel Dispensers ..... 320  
Towels & Tissues ..... 313–314, 316–319, 321–322  
Trash Bags ..... 341–344  
Vacuum Cleaners ..... 340  
Wipers ..... 266–267, 323–324
- Clip Dispensers** ..... 278
- Clips**  
Bulldog ..... 242  
Cubicle ..... 238  
Wire Shelving ..... 196
- Clocks** ..... 269–270
- CLOROX®**  
Cleaners/Disinfectants/Sanitizers ..... 266  
Disinfecting Wipes ..... 266
- Cloths**  
Cleaning ..... 324  
Dust ..... 324
- Coat Hangers** ..... 274
- Coat Racks** ..... 271–273
- COMMAND™**  
Garment Hooks ..... 274  
Hook & Loop Fasteners ..... 275–276  
Poster Strips ..... 276  
Self-Adhesive Hooks ..... 275–276
- COMPLYRIGHT®**  
Labor Law Posters ..... 335
- Computer Accessories**  
Cord Managers ..... 39  
Monitor Arms & Stands ..... 332–333
- Computer Furniture**  
Carts ..... 60–61, 63  
Sit-to-Stand ..... 38–49, 51–56, 60, 62  
Tables, Workstation ..... 63  
Workstations ..... 61, 63
- Corner Connectors** ..... 34
- COSCO INDUSTRIES, INC.**  
Hand Trucks ..... 298
- COSCO®**  
Step Ladders & Stools ..... 336
- COTTONELLE®**  
Toilet Tissue ..... 313

- CRAMER®**  
Step Stools.....336
- Credenzas**.....6-7, 9-10, 14-15, 19, 21
- Cross Rails, Lateral File**.....167, 169
- CROWN**
- Anti-Fatigue Mats.....293-294
  - Entrance Mats.....290-292
- Cubicle**
- Bulletin Boards.....241, 249
  - Clips.....238
  - Display Rails.....248
  - Dry Erase Boards.....241, 249-252
  - Nameplates.....335
  - Panel Systems.....69
- D**
- Data Cards, Magnetic**.....232
- DAX®**  
Diploma/Certificate Frames.....296-297
- Defibrillators & Pads**.....289
- DEFLECT-O®**
- Anti-Fatigue Mats.....55
  - Chair Mats.....92, 156-158
  - Outdoor Literature Boxes.....309
  - Sign Holders.....258, 335
  - Suggestion Boxes.....309
- Desk**
- Pads.....281
  - Trays.....279
  - Worksurfaces.....29
- Desk Accessories**.....277-281
- Desks**
- Metal.....35-37
  - Reception.....15
  - Shop.....198
  - Sit-To-Stand.....38-40, 46, 60
  - Standing Height.....62
- Desks, Reception Room**.....78-79
- Desktop**
- Files, Hanging Folders.....325
  - Literature Holders.....308-309
  - Literature Sorters.....310
  - Organizers.....277, 280
  - Shelves.....280
  - Sorters.....277
- Dispensers**
- Soap.....268
  - Toilet Seat Cover.....312
  - Toilet Tissue.....315
  - Towel.....318, 322
- Dome Mirrors**.....286
- Doors**
- Hutch.....14, 17
- Drawer Organizers**.....280
- Drawers**
- Desk.....8, 15, 18, 22, 34
  - Storage.....225
- Dry Erase**
- Board Easels.....254-256
  - Boards.....68, 228-241, 249-250, 258
  - Boards, Cubicle.....241
  - Calendars.....241, 249
  - Easels.....253-256
  - Erasers.....236
  - Planning Boards.....238, 241
  - Privacy Screens.....68
  - Sheets.....251-252
  - Surface.....243
- DURABLE®**  
Sign Holders & Stands.....259, 334-335
- E**
- Easels**
- Display.....258
  - Dry Erase Board.....254
  - Flip Chart.....253-256
  - Mobile.....254
  - Presentation.....253-258
  - Tabletop.....256-258
- ERGOTRON®**
- Desks, Height-Adjustable.....46
  - Monitor Arms.....49
  - Underdesk Keyboard Platforms.....46
- ES ROBBINS®**
- Anti-Fatigue Mats.....295
  - Chair Mats.....159
  - Sit-Stand Mats.....55
- EX-CELL**  
Waste Receptacles.....350
- F**
- Facial Tissue**.....321
- Fans**.....282-283
- FEBREZE®**  
Air Fresheners.....268
- FELLOWES®**  
Back Supports, Chair.....164
- Coat Hooks.....274
  - CPU Holders.....333
  - Footrests.....161
  - Height-Adjustable Table Bases.....40
  - Literature Organizers.....310
  - Mail Carts.....311
  - Nameplates.....335
  - Tables, Height-Adjustable.....40
  - Workstations.....47-48
- File**
- Boxes.....325-326
  - Carts.....67, 179-182
  - Organizers, Under-Counter.....15
- File Cabinet Seat Cushions**.....176
- File Cabinets**
- Fire Resistant.....169-170
  - Lateral.....6, 8, 17-19, 24, 30, 32, 36, 166-169
  - Mobile Pedestal.....10, 14, 19, 24, 27-30, 32, 176-178
  - Multimedia.....175, 182
  - Pedestal.....14, 17, 21-22
  - Shelf.....166
  - Vertical.....170, 174-175, 182
- File Folders**
- Hanging.....284
  - Top Tab.....285
- Files**
- Desktop.....277, 325
  - Mobile.....67, 179-182
  - Portable.....325-326
  - Roll.....226-227
  - Shelf.....166
  - Step.....279
  - Storage Drawer.....225
  - Tube.....226-227
- Fire Extinguishers**.....286
- Fire-Resistant**
- File Cabinets.....169-170
  - Safes.....171-173
- FLORITING®**
- File Cabinets.....169-170
  - Safes.....173
  - Storage Cabinets.....169
- First Aid**
- Defibrillators.....289
  - Kits & Refills.....287-288
  - Spill Clean Up Kits.....289
- FIRST AID ONLY™**  
First Aid Kits & Refills.....287-288
- Floor Cleaning Tools**
- Brooms.....261-262
  - Dust Pans.....262
  - Mop Frames & Handles.....261
  - Vacuum Cleaners.....340
- Floor Mats**.....290-295
- FLORITEX®**
- Anti-Fatigue Mats.....54
  - Chair Mats.....160
  - Footrests.....54
- Food Service Supplies**
- Refrigerators.....329
  - Towel Dispensers.....320
  - Towels.....319
  - Wipers.....318, 323-324
- Footrests**.....54, 56, 143, 161-162
- Frames**
- Certificate & Diploma.....296-297
  - Photo.....298, 334
  - Poster.....297
- Furniture**
- Bookcases.....6, 8, 15, 21, 184-188
  - Bridges, Desk.....14-16, 34
  - Cabinets, Display.....21
  - Cabinets, Storage.....6, 8, 10, 14, 19, 21, 30, 189-191, 193
  - Carrels.....66
  - Casters.....155, 206
  - Chair Mats.....156-160
  - Chairs.....20, 71-72, 81-111, 114-116, 118-127, 131-132, 137-138, 140, 142, 144-146, 148-149, 152-154
  - Chairs, Back Supports.....163-164
  - Chairs, Big & Tall.....139
  - Chairs, Folding.....217
  - Chairs, Leather.....22, 92, 113, 139
  - Chairs, Mesh.....112-113, 208
  - Chairs, Office.....22, 92, 112-113, 139
  - Chairs, Reception Room.....74-77
  - Chairs, Seat Cushions.....163-164
  - Chairs, Stacking.....92, 214
  - Chairs, Stacking/Nesting.....147, 150-151, 208, 221
  - Chairs, Task.....112
  - Computer.....38-49, 51-53, 55-56, 60-63, 66
  - Credenzas.....6-7, 9-11, 14-16, 19, 21, 32, 34-35, 37
  - Desks.....6-19, 21-23, 27-30, 32, 34-40, 46, 59-60, 62-63
  - Desks, Reception Room.....78-79
  - Desks, Table.....27, 59
  - File Cabinets, Pedestal.....67
  - Files, Fireproof.....169-170
  - Files, Lateral.....8, 15, 17-19, 24, 30, 32, 166-169
  - Files, Mobile.....67, 179-182
  - Files, Mobile Pedestal.....10, 14-15, 19, 24, 27-29, 32, 176-178
  - Files, Pedestal.....13-14, 17, 21, 30
  - Files, Safes.....171-173
  - Files, Shelf.....166
  - Files, Vertical.....170, 174-175, 182
  - Footrests.....84, 98, 143, 161-162
  - Hutches.....6, 8, 10-12, 14-15, 17-18, 21
  - Lecterns.....306
  - Legs, Desk.....24, 27
  - Locker Bases.....199
  - Lockers.....198-200
  - Machine Stands.....64-65, 330-331
  - Office Suites.....6-12, 14-16, 18-30, 32-37, 59
  - Ottomans.....77
  - Panel Systems.....69
  - Privacy Panels/Screens.....68-69
  - Reception Desk.....23
  - Reception Room.....15, 71-72, 74-79, 202
  - Returns, Desk.....6, 12, 14, 32, 34
  - Shelving.....192-197
  - Sofas, Reception Room.....71-72, 74
  - Stools.....50-53, 96, 100, 102, 109, 115, 118, 122, 124-128, 131, 133-136, 141-142, 150-151
  - Stools, Extended-Height.....62
  - Table Desks.....27, 59
  - Tables.....15, 17, 29, 36, 38-40, 71-72, 203, 209-210, 218, 220
  - Tables, Conference.....21, 204
  - Tables, Drafting/Drawing.....226
  - Tables, Folding.....212-217
  - Tables, Height-Adjustable.....46, 60
  - Tables, Hospitality.....219
  - Tables, Indoor/Outdoor.....221-222
  - Tables, Meeting Room.....10
  - Tables, Occasional.....74, 202
  - Tables, Picnic.....222
  - Tables, Standing-Height.....62
  - Tables, Training.....205-208, 211
  - Tables, Utility.....212
  - Workstations.....28, 41-43, 47-48, 59
  - Workstations, Modular.....23, 59
  - Workstations, Sit-To-Stand.....44-45, 60
  - Workstations, Table.....63
  - Worksurfaces, Desk.....16
- G**
- Ganging Hardware, Chairs**.....205
- Garbage Cans**.....345-350
- Garment Racks**.....197, 271, 273
- GE**
- Light Bulbs.....304-305
- GLADE®**  
Air Fresheners.....268
- GLAD®**  
Trash Bags.....344
- Glides, Chair**.....155
- Glues & Adhesives**  
Mounting Products.....276
- GREAT NECK®**  
Tool Kits/Sets.....337
- Grommets**.....15
- GUARDIAN**  
Anti-Fatigue Mats.....295
- Entrance Mats.....292-293
- H**
- Hand Trucks/Platforms Trucks**.....298
- HANDI-BAG®**  
Trash Bags.....343
- Handles**
- Broom.....261
- Hangers, Coat**.....274
- Hanging File Folders**.....284
- Hangrails, File Cabinet**.....167, 169
- HEADLINE® SIGN**  
Business Hours Signs.....335
- Headrests, Chair**.....114
- Healthcare**
- Blood Clean Up Kits.....289
  - First Aid Stations & Refills.....287-288
- Heaters**.....300-301
- HEFTY®**  
Trash Bags.....344
- HOLMES®**  
Fans.....282-283
- HONEYWELL®**  
Fans.....282-283
- Heaters.....300-301
  - Humidifiers.....301
- HON®**
- Bookcases.....6, 8, 186-188
  - Bridges, Desk.....10-11, 16, 32, 34
  - Cabinets, Storage.....6, 8, 10
  - Café/Bistro.....96
  - Chair Arms.....124, 127-128, 132
  - Chair Carts.....147-148
  - Chairs.....26, 71, 82, 89, 92-96, 104-105, 107-108, 111, 114-119, 121-122, 124, 127, 138-139, 144-145, 147-148, 150-151
  - Chairs, Mesh.....208



- HON® (Cont.)**
- Chairs, Reception Room ..... 74
  - Chairs, Stacking/Nesting ..... 208
  - Corner Connectors ..... 34-35
  - Credenzas ..... 6-7, 9-11, 16, 32, 34-35
  - Desks ..... 6-12, 16-17, 32-36
  - Drawers ..... 8, 34
  - File Cabinets ..... 17, 29, 32, 36, 175, 177
  - File Cabinets, Lateral ..... 6, 8, 167-168
  - File Cabinets, Mobile Pedestal ..... 10, 13, 27
  - File Cabinets, Vertical ..... 174
  - Ganging Hardware, Chairs ..... 205
  - Hutches ..... 6, 8, 10-12, 17
  - Keyboard Drawers/Platforms ..... 6, 8, 12, 34-35
  - Lamps ..... 6, 8, 12, 34
  - Lock Core Kits ..... 12, 167, 174
  - Modesty Panels ..... 17, 27, 208
  - Modesty Panels, Table ..... 205
  - Notebook Computer Risers ..... 41
  - Panel Systems ..... 69
  - Power Hubs ..... 6, 12, 27
  - Reception Room Furniture ..... 71, 74, 202
  - Returns, Desk ..... 6, 10-13, 32, 34-35
  - Sofas ..... 71, 74
  - Stools ..... 52, 115, 118, 122, 124, 127-128, 130, 132, 134, 141, 150
  - Storage Cabinets ..... 190
  - Table Bases ..... 40
  - Tables ..... 36, 40, 71
  - Tables, Conference ..... 203
  - Tables, Hospitality ..... 219
  - Tables, Meeting Room ..... 12
  - Tables, Occasional ..... 74, 202
  - Tables, Training ..... 205-208
  - Tables, Utility ..... 212
  - Wardrobe Cabinets ..... 17
  - Worksurfaces, Desk ..... 27, 29
- Hooks**
- Coat ..... 274
  - Self-Adhesive ..... 275-276
  - Wire Shelving ..... 196
- HOVER COMMERCIAL**
- Vacuum Cleaners ..... 340
- HOWARD MILLER®**
- Clocks ..... 269-270
- Hutch Doors** ..... 17
- Hutch Supports** ..... 21
- Hutches** ..... 6, 8, 10-12, 14-15, 17-18, 21, 32
- I**
- ICEBERG**
- Boards ..... 245
  - Chairs ..... 152, 154
  - Dry Erase Boards ..... 230-231
  - Easels ..... 253
  - Shelving ..... 193
  - Storage Cabinets ..... 193
  - Table Covers ..... 222
  - Tables ..... 209, 218
  - Tables, Folding ..... 213, 215, 222
- INNOVERA®**
- CPU Holders ..... 333
  - Monitor Arms/Risers & Stands ..... 332
- Interoffice Mailbox** ..... 309
- J**
- JAGUAR PLASTICS®**
- Trash Bags ..... 341-343
- JOHNSON & JOHNSON®**
- First Aid Kits ..... 288
- K**
- KANTEK**
- Desk Accessories ..... 280
  - Footrests ..... 161
  - Monitor Risers & Stands ..... 332
  - Printer Stands ..... 333
- KENSINGTON®**
- Footrests ..... 162
  - Monitor Stands ..... 332
- Key Drop Boxes** ..... 309
- Keyboard Drawers/Platforms**
- Underdesk ..... 6, 8, 12, 46
- Keyboard Shelves** ..... 15
- KIDDE**
- Alarms & Fire Extinguishers ..... 286
- KIMBERLY-CLARK PROFESSIONAL®**
- Toilet Tissue Dispensers ..... 315
  - Towel Dispensers ..... 318
- KIMTECH®**
- Wipers, Delicate Task ..... 323
- KLEENEX®**
- Facial Tissue ..... 321
  - Towels ..... 316, 322
- L**
- Ladders** ..... 336
- LAKEWOOD**
- Fans ..... 282
- Lamps**
- Desk ..... 302-303
  - Floor ..... 302
  - Under Cabinet ..... 6, 8, 12, 15, 19, 34
- Lecterns** ..... 306
- LEDU**
- Lamps ..... 302-303
- Legs**
- Desk ..... 24, 27
- Letter Trays & Sorters** ..... 279-280
- Lids, Waste Receptacle** ..... 348
- Light Bulbs** ..... 303-305
- Lighting, Desk Lamps** ..... 302-303
- Lighting, Under Cabinet** ..... 6, 8, 15, 19, 34
- LINEA ITALIA®**
- Bookcases ..... 28
  - Desks, Reception Room ..... 78-79
  - File Cabinets ..... 28
  - Pedestal File Cabinets ..... 177
  - Privacy Screens ..... 28
  - Study Carrels ..... 66
  - Table Desks ..... 59
  - Tables ..... 28, 59
- Literature**
- Holders & Suggestion Boxes ..... 309
  - Organizers ..... 310
  - Racks & Displays ..... 307-309
- Lock Core Kits** ..... 15, 24
- Lock Core Kits, File Cabinet** ..... 12, 167, 174, 182
- Locker Bases** ..... 199
- Lockers** ..... 198, 200
- LOUISVILLE®**
- Ladders & Stools ..... 336
- Love Seats, Reception Room** ..... 71-72, 75, 77
- LYSOL® BRAND**
- Cleaners & Disinfectants ..... 266, 268
- M**
- Magazine Files** ..... 279
- Magazine Racks** ..... 307-308
- Magnetic**
- Board Accessories ..... 232, 242
  - Bulletin Boards ..... 244
  - Dry Erase Boards ..... 228-229, 231-241, 249-252
- Magnets** ..... 238, 241
- Mail Carts** ..... 197, 311
- Mailroom & Shipping**
- Mail Carts ..... 311
- Markers**
- Dry Erase ..... 236, 252
- MASTER CASTER®**
- Chair Casters & Glides ..... 155
  - Doorstops ..... 337
- MASTERSERVISION™**
- Board Accessories ..... 232-234, 242
  - Boards ..... 232-233, 235-236, 239, 241, 244-247, 249, 252-255
  - Boards, Dry Erase ..... 231
  - Easels ..... 253, 255, 257-258
  - Sign Stands ..... 259
- Mats**
- Anti-Fatigue ..... 43, 54-55
  - Anti-Fatigue Mats ..... 293-295
  - Chair ..... 156-160
  - Floor ..... 290-295
  - Sit-To-Stand ..... 43, 54-55
- Mirrors, Security** ..... 286
- Modesty Panels** ..... 17, 205, 208, 210
- Monitor, Arms** ..... 41-43, 49
- MURPHY® OIL SOAP**
- Furniture Cleaners ..... 267
- O**
- CEDAR COMMERCIAL™**
- Brooms ..... 262
- Office Suites**
- Laminate ..... 6-22, 24-26, 30
  - Steel ..... 23, 32-37
  - Table Desks ..... 27-29, 59
- OFFICEMATE OIC**
- Magnets ..... 242
- OLD ENGLISH®**
- Furniture Polish Cleaners ..... 267
- Organizers**
- Literature ..... 310
- Ottomans, Reception Room** ..... 73, 77
- P**
- Pack & Ship**
- Mail Carts ..... 197, 311
- Pads**
- Desk ..... 281
- Panel Systems, Office** ..... 68-69
- Paper Towels** ..... 322
- Pencil Cups** ..... 278-279
- PENDAFLEX®**
- File Boxes ..... 325-326
- File Folders** ..... 284
- PEOPLE POINTER™**
- Nameplates ..... 335
- Photo/Picture Supplies**
- Adhesives & Mounting Supplies ..... 276
  - Frames ..... 296-297, 334
- PHYSICIANS CARE®**
- First Aid Kits & Medicines ..... 288
- Planners, Dry Erase Wall** ..... 241, 243
- Platform Trucks** ..... 298
- PLATINUM PLUS®**
- Trash Bags ..... 342
- PLEDGE®**
- Furniture Polish Cleaners & Wipes ..... 267
- POST-IT™**
- Board Accessories ..... 232
  - Dry Erase Surfaces ..... 243
  - Easel Pads ..... 256
  - Posters, Labor Law ..... 335
  - Posts, Wire Shelving ..... 196
- Power Supplies**
- Power Hubs ..... 6, 8, 12, 27
  - Surge Protectors ..... 327-328
  - UPS Backup Systems ..... 327
- Privacy Screens**
- Dry Erase ..... 68
  - Table Top ..... 24, 28
  - Workstation ..... 68
- PURELL®**
- Hand Soaps ..... 268
  - Soap Dispensers ..... 268
- Push Pins** ..... 244, 246, 248
- Q**
- QUARTET®**
- Board Accessories ..... 236, 242, 252
  - Boards ..... 228-230, 233-235, 237, 240-241, 244, 246-247, 249-250, 254-256, 258, 260
  - Boards, Dry Erase ..... 231
  - Coat Hooks/Garment Racks ..... 271
  - Dry Erase Markers ..... 252
  - Easels ..... 255, 257-258
  - Privacy Screens, Workstation ..... 68
  - Sign Holders/Stands ..... 259, 335
  - Wet Erase Markers ..... 252
- R**
- Racks**
- Literature ..... 307-308
- Reception Room**
- Benches ..... 75
  - Chairs ..... 71-77
  - Desks ..... 78-79
  - Love Seats ..... 71-72, 75, 77
  - Ottomans ..... 73, 77
  - Sofas ..... 74
  - Tables ..... 71-73
  - Tables, Occasional ..... 74, 202
- Record Storage** ..... 225
- Recycling Receptacles** ..... 347-348
- Refrigerators** ..... 329
- Restroom Supplies**
- Cleaners ..... 266
  - Dispensers, Toilet Seat Cover ..... 312
  - Dispensers, Toilet Tissue ..... 315
  - Dispensers, Towel ..... 318
  - Facial Tissue ..... 321
  - Soaps ..... 268
  - Toilet Seat Covers ..... 312
  - Toilet Tissue ..... 313-314
  - Towel Dispensers ..... 320
  - Towels ..... 316-317, 319
- Returns**
- Desk ..... 6, 10-12, 14-15, 17, 19, 21, 32, 34-35
- Risers**
- Monitor ..... 332
- RUBBERMAID® COMMERCIAL**
- Brooms ..... 262
  - Carts ..... 264
  - Dust Pans ..... 262
  - Platform Trucks ..... 298
  - Service Carts ..... 339
  - Step Stools ..... 336
  - Utility Carts ..... 338-339
  - Waste Receptacles ..... 349
  - Waste Receptacles & Lids ..... 345-348
- S**
- SAFACACTIVE**
- Balance Boards ..... 143
  - Footrests ..... 143
  - Stools ..... 51, 53
- SAFCO®**
- Anti-Fatigue Mats ..... 55
  - Back Supports, Chair ..... 163
  - Balance Boards ..... 56
  - Bins ..... 182
  - Bookcases ..... 21
  - Cabinets ..... 21, 30

## SAFCO® (Cont.)

Carts	63, 67, 152-153, 179-182, 263, 265, 298-299, 306, 311
Chair Arms	130-131, 139
Chairs	20, 92, 112, 131, 139, 150, 152
Chairs, Ball	50
Chairs, Stacking	221
Coat Racks/Hangers	272-274
Credezas	21
Desk Accessories	280, 325
Desks	21, 30, 59, 66
Desks, Standing-Height	60, 62
Easels	254-255
File Cabinets	30
Files	67, 226-227, 310, 325
Footrests	56, 143, 161-162
Hutch Supports	21
Hutches	21
Lecterns	306
Literature Organizers	307-308, 310
Lockers	200
Magazine Racks	307
Mobile Files	179-182
Monitor/Machine Stands	64, 330
Privacy Screens, Dry Erase	68
Returns, Desk	21
Seat Cushions, Chair	163
Shelving	182, 193
Shelving, Commercial	192
Shelving, Industrial	192
Stands	65, 331
Stands, Monitor	45
Stools	52, 62, 66, 130-131, 134-136
Suggestion Boxes & Cards	309
Table Desks	59
Tables, Conference	21, 204
Tables, Drafting	226
Tables, Outdoor	221
Tables, Training	211
Tables, Workstation	63
Tubes	226-227
Utility Carts	338
Waste Receptacles	345, 350
Workstations	59-61, 63
<b>Safes</b>	
Fireproof	171-173
Laptop	173
<b>Safety &amp; Security</b>	
Alarms & Visitor Chimes	286
Mirrors	286
Safety Signs & Crowd Control	335
<b>SAN JAMAR®</b>	
Towel Dispensers	318
<b>SANITAIRE®</b>	
Vacuum Cleaners	340
<b>SCOTT®</b>	
Toilet Seat Covers & Dispensers	312
Toilet Tissue	313-314
Toilet Tissue Dispensers	315
Towel Dispensers	320
Towel Rolls	322
Towels	319
Towels & Dispensers	316
<b>Seat Cushions, Chair</b>	163-174
<b>Seat Cushions, Chair/File Cabinet</b>	176
<b>Security Mirrors</b>	286
<b>SEE ALL®</b>	
Security Mirrors	286
<b>Service Carts</b>	263-264, 338-339
Sheet Files	227
<b>Shelf Liners, Wire Shelving</b>	196
<b>Shelves</b>	
Desktop	280
<b>Shelving</b>	
Archival	193
Blow-Molded Poly	193
Boltless	193
Commercial	192
Industrial	192
Mesh Cube	182
Steel	192-193
Wire	194-197
<b>Shop Towels</b>	323
<b>Sign Holders</b>	334-335
<b>Sign Stands</b>	258-259
<b>Signs</b>	
Business Hours	335
Safety	335
<b>SMEAD®</b>	
Boards	243
File Folders	284-285
<b>Smoke &amp; Carbon Monoxide Alarms</b>	286
<b>Soaps, Hand</b>	268
<b>Sofas, Reception Room</b>	71-72, 74
<b>Sorters</b>	
Desktop	277, 280
File Folder	279
Literature	310
<b>Stands</b>	
Laptop	45

Machine	61
Monitor	45, 332-333
Printer/Machine	64-65, 330-331
Sign	258-259
Telephone	277, 280
<b>STANLEY®</b>	
Tool Kits	337
<b>Step Ladders/Step Stools</b>	336
<b>Stools</b>	
Active	51-53
Backless	134-136
Ball Chair	50
Big & Tall	139
Café/Bistro	96, 115, 136, 150-151
Extended Height	131, 133-134
Healthcare	134, 141
Industrial	133, 135, 141
Lab	134
Mesh	100, 102, 109, 115, 118, 124, 128-130, 142, 150
Multipurpose	136, 150
Office	134
Perch	43, 52-53, 142
Stacking	151
Stacking/Nesting	142
Task	100, 102, 118, 122, 124, 126-130
Task/Lab	134
Workbench	135, 141
<b>Storage</b>	
Bins, Mesh Shelving Unit	182
Bookcases	184-188
Boxes	325
Cabinets	6, 8, 10, 21, 30, 189-191, 193
Carts, File	67, 179-182
File Cabinets	175-178
File Cabinets, Fire Resistant	169-170
File Cabinets, Lateral	6, 8, 30, 166-169
File Cabinets, Mobile Pedestal	27, 63
File Cabinets, Pedestal	12, 30
File Cabinets, Shelf	166
File Cabinets, Vertical	170, 174, 182
Lockers	198-200
Shelf Files	166
Shelving Accessories	192
Shelving, Archival	193
Shelving, Blow-Molded Poly	193
Shelving, Boltless	193
Shelving, Commercial/Industrial	192
Shelving, Mesh Cube	182
Shelving, Steel	192-193
Shelving, Wire	194-197
Tubes, Document	226-227
<b>STOREX</b>	
File Cabinets	67, 178
File Totes	326
Literature Sorters	310
<b>Suggestion Boxes &amp; Cards</b>	309
<b>SURE SEAL BY FIREKING®</b>	
Fire-Safe Chests	173
<b>Surge/Power Supplies</b>	
Surge Protectors	328
UPS Battery Backup	327
<b>T</b>	
<b>Table Bases</b>	10, 38, 40, 46, 204-208, 210-211, 219-221, 226
<b>Table Covers</b>	222
<b>Table Desks</b>	27, 30, 59
<b>Table Tops</b>	10, 39-40, 46, 204-206, 208, 210-211, 219-221, 226
<b>Table, Carts</b>	217
<b>Tables</b>	
Casters	206
Conference	15, 21, 203-204
Drafting/Drawing	226
Folding	212-217
Height-Adjustable	220
Hospitality	218-220
Indoor/Outdoor	216, 221
Meeting Room	21
Occasional	71-74, 76-77, 202
Sit-To-Stand	209
Training	205-211
Utility	36, 212, 216
Workstation	63
<b>Tags</b>	
Wire Racks/Shelves	196
<b>Tape Measures</b>	337
<b>TATCO</b>	
Cable Ties	337
<b>Telephone Stands</b>	277
<b>TENNESCO</b>	
Bookcases, Metal	187
Cabinets, Storage	190-191
File Cabinets, Multimedia	182
Locker Bases	199
Lockers	198-199
Shelf Files	166
Shelving, Commercial	192
Shelving, Industrial	192

Shop Desks	198
<b>Tissue, Toilet</b>	313-314
<b>Toilet Seat Covers &amp; Dispensers</b>	312
<b>Tools</b>	337
<b>Top Tab File Folders</b>	285
<b>TORK®</b>	
Facial Tissue	321
Toilet Seat Covers & Dispensers	312
Toilet Tissue	313-314
Toilet Tissue Dispensers	315
Towel Dispensers	318, 320
Towel Rolls	322
Towels	317, 319
Wipers	323
<b>Towel Dispensers</b>	318
<b>Towels</b>	
Folded	316-317
Roll	319
Shop	323
<b>Trash Bags</b>	341-344
<b>Trays</b>	
Desk	277-279
<b>TRIPP LITE</b>	
CPU Holders	333
Surge Protectors	328
UPS Backup Systems	327
<b>Tube Files</b>	226-227
<b>Tubes, Document</b>	226-227
<b>U</b>	
<b>Umbrella Stands</b>	272
<b>UNIVERSAL®</b>	
Board Accessories	242
Boards	228-230, 233-236, 245, 248-249, 251, 256
Call Bells	335
Clocks	269-270
Coat Hooks, Cubicle	274
Cork Bulletin Bar	252
Desk Accessories	277-279
Easels	257
File Boxes	225
Files, Mobile	325-326
Push Pins	246
Sign Holders	334
<b>Utility Carts</b>	338-339
<b>V</b>	
<b>Vacuums</b>	
Carpet/Floor	340
<b>VAULTZ®</b>	
Locking File Boxes	325
<b>VERTIFLEX®</b>	
Beverage Carts	265
File Carts	179, 181
Machine Stands	65, 331
Media	306
<b>VICTOR®</b>	
Balance Boards	56
Footrests	143
Monitor Stands	45
Sit-To-Stand Workstations	44-46
<b>W</b>	
<b>Waste Can Liners</b>	341-344
<b>Waste Receptacles</b>	
Dome Top	346
Fire-Safe	345
Half-Round	346
Open Top	346
Outdoor	350
Recycling	347-348
Refuse & Heavy Duty	349
Side-Opening	346
Wheeled	349
<b>Wastebaskets</b>	345-348
<b>Wipers</b>	323-324
<b>Wipes</b>	
Disinfecting	266
Furniture	267
<b>Wood Cleaners</b>	267
<b>WORKFIT™ BY ERGOTRON®</b>	
Anti-Fatigue Mats	55
Desks, Height-Adjustable	46
Workstations	41, 47-48
<b>Workstation</b>	
Tables	59-63
<b>Workstations</b>	
Computer	41-45, 47-48, 60-63
Sit-to-Stand	41-48, 60
<b>Worksurfaces, Desk</b>	27, 29
<b>WYPALL®</b>	
Wipers	323
<b>Z</b>	
<b>ZOLL®</b>	
Defibrillators & Accessories	289